

# SENATOR™ G2 280-21



**4060**  
PSI

**21**  
L/PM

**HONDA GX690**  
PETROL  
ENGINE TYPE  
POWERED by HONDA

**GEARBOX**  
1450RPM  
DRIVE

**COLD WATER**  
OUTPUT



--- Optional - Trolley Kit

## HERO INNOVATIONS



**PEXO™**  
Stainless Steel Exoskeleton



**JWPP™**  
Jetwave Italian Premium Pump



**CC™**  
Centralised Control



**AVPS™**  
Anti Vibration Protection System



**MC™**  
Multi Configuration



Senator G2 Video

## APPLICATIONS



Tradesmen



Commercial Cleaners



Shipping & Logistics



Hire & Rental



## STANDOUT FEATURES



JW® Enhanced Italian triplex plunger pump running at 1450RPM delivers more performance and longer life.



Electric start Industrial V-Twin Honda™ GX690 Series Engine with digital engine hour meter.



Jetwave Safety System™ (JSS) thermal and safety valve to prevent overheating in excessive bypass and over pressurisation.



Seamless & sealed 40L on-board oversized water bypass tank w/low level cut out, for unit water supply and pump protection.



Battery isolator & Emergency stop for increased safety and longevity.



Seamless under chassis mounted 25L fuel tank (w/level gauge) protected from heat with front fill point safety.

## STANDARD EQUIPMENT



J5000™ High Pressure Gun + Twin Lance with Nozzles.



15m Double Wire Braid Hose with M22 Couplings.

## DIMENSIONS (MM)

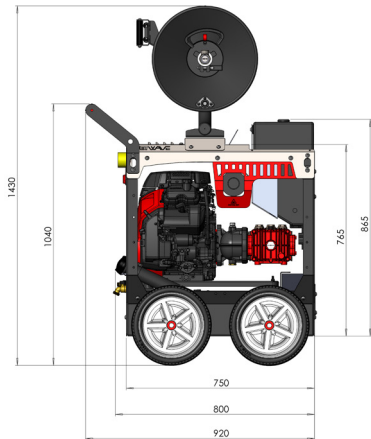
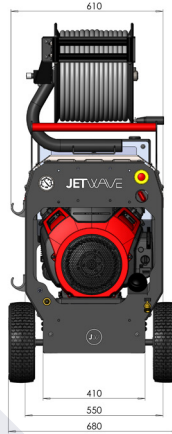

## TECHNICAL DATA 0:00

## SENATOR<sup>™</sup> G2 280-21

Product Code	CW4000-21PEG2
Pressure / Flow Rate	4060 PSI (280 BAR) / 21 L/PM
Max Water Inlet Temp	60C°
Class (ASNZS: 4223)	B (5,880 Bar/Litres)
Usage Frequency	Professional: 4 Hours Daily
Nozzle Size	05
Frame Structure	CNC Modular galvanised steel chassis plus satin powder coat finish and <b>stainless steel cover</b>

## MOTOR FEATURES

Engine / Power	Honda™ GX690 Electric Key Start (air cooled) 23HP / 690cc
Fuel Type / Capacity / Protection	Unleaded / 25L (w/level gauge) / Low Oil Shutdown

## HYDRAULIC FEATURES

Pump / Head / Pistons	JW® Italian Triplex Plunger / Brass (Nickle Plated) / Ceramic
Motor Pump Coupling / Pump RPM	Gearbox Drive / 1450RPM
Unloader Valve	Independent (Panel Mounted)
Safety Valve	Yes
Detergent Injector	Yes - Downstream low pressure (power boost)

## DIMENSIONS & WEIGHT

Machine Dimensions / Weight	Skid: 750mm(L) x 550mm(W) x 765mm(H) / 150KG (approx.)
-----------------------------	--

## WARRANTY(S)

Unit / Pump Warranty*	2 Years
Engine Warranty*	3 Years

## OPTIONAL ACCESSORIES

30m Hose Reel	1060CMPL
60m Hose Reel	1067CMPL
Additional High Pressure Hose	52001
JW12 Foaming Lance w/1L Tank	JWA221-LS12
JW Bypass Pro Foam	PROFOAM
Turbo Head w/Lance (300BAR)	JWA160
21" Hammerhead - Plastic	JWA-FSC21

## OPTIONAL UPGRADES

iGX700 EFI Engine Upgrade	ADD:FI
4 Wheel Trolley Kit	JWA407A
Front Double Stack Kit	JWA-429C
Top Double Stack Kit	JWA-430C
Low Pressure Inlet Hose Reel w/30m hose	1065CMPLLP
Hose Reel Roller Guide System HGS™	1067-GUIDEASSY (1067 Only)

The manufacturer reserves the right to modify design features and technical facts without notice, due to our principals of continuous improvement.  
\*Coverage against defects in material and workmanship (refer to Jetwave's and component partners T&Cs).

V2.3 04/22