



OWNER'S MANUAL
PRODUCT CODE: 1146T

60 Litre TRUCK OIL DRAINER PAN



Capacity	Height from Ground	Screen Dimensions	Dimensions
60 Litres	196mm	802(L) x451(W) x3(D)mm	1174(L) x 641(W) x 673(H)

WARNING**IMPORTANT: READ ALL INSTRUCTIONS BEFORE USE****WARNING**

The instructions and warnings contained in this manual should be read and understood before using or operating this equipment. Do not allow anyone to use or operate this equipment until they have read this manual and have developed a thorough understanding of how this equipment works. Failure to observe any of the instructions contained in the manual could result in severe personal injury to the user or bystanders, or cause damage to the equipment and property. Keep this manual in a convenient and safe place for future reference.

Whilst every effort has been made to ensure accuracy of information contained in this manual, the TQB Brands Pty Ltd policy of continuous improvement determines the right to make modifications without prior warning.

CONTENT

WARNING	2
CONTENT	2
SAFETY INSTRUCTIONS	3
ASSEMBLY, OPERATION, PREVENTITIVE MAINTENANCE	4
PARTS LIST	7
WARRANTY	8

SAFETY INSTRUCTIONS



SAFETY OPERATING INSTRUCTIONS

- ✓ Before using the 60 Litre Truck Oil Drainer Pan ensure it is in sound condition, and good working order.
- ✓ Replace or repair damaged parts. *Use recommended parts only. Non authorised parts may be dangerous and will invalidate the warranty.*
- ✓ Spillages of liquid material, which may be slippery, must be cleaned up immediately to avoid injury.
- ✓ Before using the Oil Drainer, the vehicle's engine must be off. Place the transmission in park (automatic transmission) or in gear (manual transmission) and apply the park brake.
- ✓ Operators should maintain correct balance and footing. Ensure the floor is not slippery and wear non slip shoes.
- ✓ Wear approved ear, eye, hand and respiratory protection when operating this product.
- ✗ DO NOT operate unit if any parts are missing or damaged as this may cause failure and/or personal injury.
- ✗ DO NOT allow untrained persons to operate the product.



WARNING - Oil in the vehicle's oil pan may be extremely hot and has the potential to burn; be careful to avoid contact with skin.

ASSEMBLY, OPERATION, PREVENTITIVE MAINTENANCE

1. FEATURES

The 60 Litre Truck Oil Drainer Pan is used for collecting used oil. It is ideal for draining oil from 4WD, trucks, heavy industrial equipment maintenance and repair.

The oil is collected into the 60 litre steel reservoir. A metal grate prevents oil spillage during the vehicle draining process and used oil transfer to and from the oil disposal reservoir. The drainer is fitted with two fixed rear wheels and two front swivel castors and grab handle for ease of under vehicle positioning. Used oil can be transferred by either gravity or suction evacuation.

2. ASSEMBLY

Unpacking: After removing the packing material, make sure the product is in perfect condition and that there are no visible damaged parts. The packaging materials (polyethylene bags, polystyrene etc) must be disposed on in an appropriate refuse collection container. These materials must not be left within the reach of children as they are potential sources of danger.

1. Attach the Handle (3) by fitting it inside the bracket between the two front castor brackets. Secure with Bolt (7), Washer (6) and Nut (5).
2. The front swivel Castors (10) fit on the brackets on each side of the Handle (3).
3. Insert a swivel Castor (10) through the hole in the bracket from the bottom and attach with a Washer (9) and a Nut (8). Repeat on opposite side.
4. The fixed Wheels (15) attach on the opposite side of the Oil Drain. Push the wheel Axle (13) through the axle bracket and slide on a Washer (9) and the Wheel (15). Secure with a Washer (9) and a Nut (8). Repeat on opposite side.
5. Before threading the Valve (12) onto the Coupler on the front of the drain, wrap teflon thread sealing tape (not included) clockwise around the Coupler. Thread on the Valve (12) ensuring the valve lever faces upward.

3. BEFORE USE

Prior to each use conduct a visual inspection by checking for abnormal conditions, such as cracked joints and damaged, loose, or missing parts.

4. OPERATION



WARNING: Before using the Truck Oil Drainer, the vehicle's engine must be off. Place the transmission in park (automatic transmission) or in gear (manual transmission) and apply the parking brake. Oil in the vehicle's oil pan may be extremely hot and has the potential to burn; be careful to avoid contact with skin.

1. Roll the Truck Oil Drainer under the vehicle directly under the drain sump plug of the vehicle. Ensure the lever on the Valve (12) is perpendicular to the valve and in the off position.
2. Open the sump plug and allow oil to flow into the Truck Oil Drainer.
3. When the oil has been completely drained from the vehicle, replace the vehicle's sump plug and roll the Oil Drainer out from under the vehicle.
4. The Oil Drainer offers two options to transfer the used oil into an approved oil storage container;

Option 1:

Gravity Flow: Roll the Oil Drain directly over the approved storage tank and make sure the Valve (12) sits directly over the container. Turn the lever on the Valve (12) parallel to the Valve (12) to release the oil. For added convenience attach a rubber hose (not included) using a hose clamp (not included) to the barbed fitting on the Valve (12).

Option 2: (Pump not included)

Manual or Electric Pump: Follow the directions in Option 1, utilising the rubber hose and hose clamp (not included). Attach the hose (not included) from a manual pump or an electric pump to the Coupler (16). You may require an adapter (not included) to fit your specific hose size to the Coupler (16). Begin hand cranking the manual pump, or turn on the electric pump to the lowest possible setting, and the oil will be suctioned out of the Valve (12). Pressure can be increased but ensure this is done slowly.

Caution: Oil residue will remain after the collected oil has been removed from the Oil Drainer. Store the Oil Drainer away from all ignition sources and flammable materials. Wipe off Oil Drainer with a rag to remove oil residue.

5. STORAGE

This 60 Litre Truck Oil Drainer Pan should always be stored in a dry location. Store the Oil Drainer away from all ignition sources and flammable materials. Wipe off Oil Drainer with a rag to remove oil residue.

6. MAINTENANCE

Replace or repair damaged parts. Use recommended parts only. Non authorised parts may be dangerous and will invalidate the warranty.

1. After each use, remove the Filter Screen (1) and clean off any debris which accumulates.
2. Periodically check the tightness of all components, bolts, nuts, wheels, castors and the handle.
3. Occasionally open the Valve (12) and run a pipe cleaner through the Valve (12) to clear out any dirt or debris.

7. SERVICE & REPAIR

Any 60 Litre Truck Oil Drainer Pan found damaged in any way, or found to be worn or operates abnormally should be removed from service until repaired by an authorised service agent. Owners and / or operators should be aware that repair of this product may require specialised equipment and knowledge. Only authorised parts, labels and decals shall be used on this equipment. Annual inspection of the 60 Litre Truck Oil Drain Pan is recommended and can be made by an authorised repair facility to ensure that your equipment is in optimum condition and that the equipment has the correct decals and safety labels specified by the manufacturer.

PARTS LIST

Part	Description	Qty	Part	Description	Qty
1	Filter Screen	1	9	Washer	4
2	Handle Grip	1	10	Castor	2
3	Handle	1	11	Coupler	1
4	Reservoir	1	12	O-Ring	1
5	Nut	1	13	Bolt	2
6	Washer	1	14	Bearing	2
7	Bolt	1	15	Nylon Washer	2
8	Nut	4	16	Valve	1

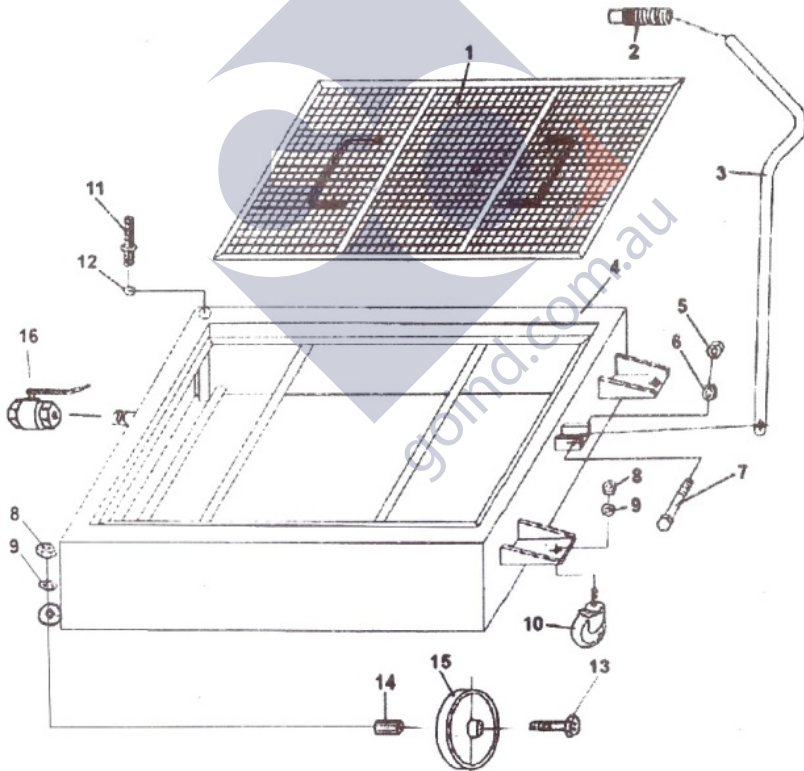

WARRANTY

Tradequip products have been carefully tested and inspected before shipment and are guaranteed to be free from defective materials and workmanship for a period of 12 months from the date of purchase except where tools are hired out when the guarantee period is ninety days from the date of purchase.

Should the machine develop any fault, please return the complete tool to your nearest authorised warranty repair agent or contact TQB Brands Pty Ltd Warranty team – warranty@tqbbrands.com.au.

If upon inspection it is found that the fault occurring is due to defective materials or workmanship, repairs will be carried out free of charge. This guarantee does not apply to normal wear and tear, nor does it cover any damage caused by misuse, careless or unsafe handling, alterations, accident, or repairs attempted or made by any personnel other than the authorised TQB Brands Pty Ltd repair agent.

This guarantee applies in lieu of any other guarantee expressed or implied and variations of its terms are not authorised.

Your TQB Brands Pty Ltd guarantee is not effective unless you can produce upon request a dated receipt or invoice to verify your proof of purchase within the 12 month period.

Consumer Guarantee

Our goods come with a guarantee that cannot be excluded under the Australian Consumer Law. You are entitled to a replacement or refund for a major failure and compensation for any other reasonably foreseeable loss or damage. You are also entitled to have the goods repaired or replaced if the goods fail to be of acceptable quality and the failure does not amount to a major failure.