



KITS



PUMPS



METERS



METERED NOZZLES



NOZZLES



WASTE OIL EQUIPMENTS

MA 180

FEATURES

- IN/OUT SWAPPABLE
- BUILT-IN DIFFUSER
- SUITABLE FOR IMMERSED INSTALLATION
- HEAVY DUTY
- EXPLOSION PROOF (EX ZONE 2)
- EASY TO FIT
- STURDY DESIGN

The PIUSI MA 180 is a long life pneumatic diaphragm pump suitable for transferring high viscosity fluids and waste oils. The small size of this pump allows a wide range of possible installations.



PERFORMANCE

UP TO 150 L/MIN	MAX 7 BAR
FLOW RATE	AIR PRESSURE
5M MAX CAPACITY	MAX Ø 4MM
SELF PRIMING	PASSING SOLID



MA 180



PACKAGING

CODE	WEIGHT		PACKAGING			
	KG	LBS	MM	INCH	PCS/PALLET	PCS/BOX
FOO208A10	8,2	18,1	270X390X400	10,6X15,4X15,7	-	1



FILTRATION



FLUID MONITORING



TANK MONITORING



HOSE REELS



ACCESSORIES



MERCHANDISE



AIR



ANTIFREEZE



AdBlue®



BIODIESEL



DIESEL



FOOD



GASOLINE



GREASE



KEROSENE



OIL



WATER



WINDSCREEN

CHART

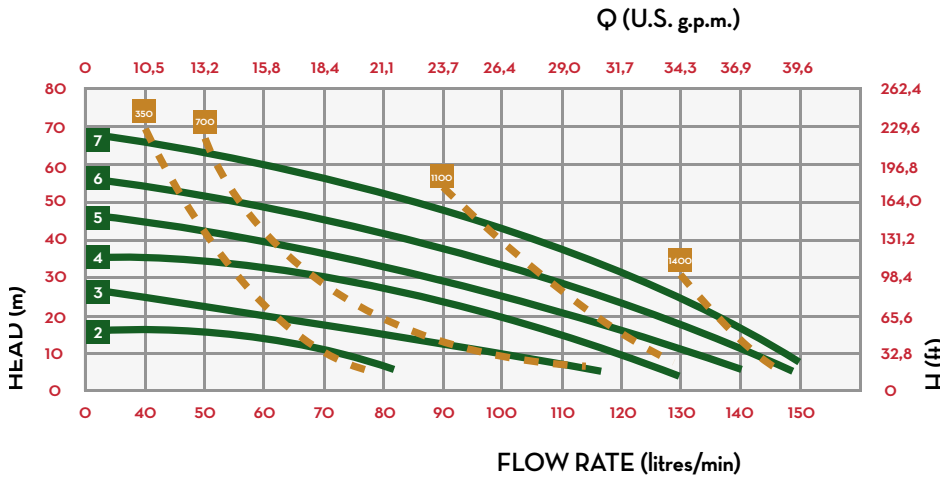

IN THE BOX

- MA 180 PUMP
- INSTRUCTION MANUAL



DETAILS



HEAVY DUTY MATERIALS



TECHNOPOLYMER BODY

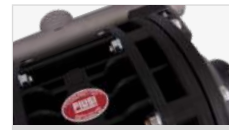

STURDY DESIGN

MATERIALS

- BODY: TECHNOPOLYMER
- FITTINGS: ALLUMINIUM
- DIAPHRAGMS: TECHNOPOLYMER

DIMENSIONS

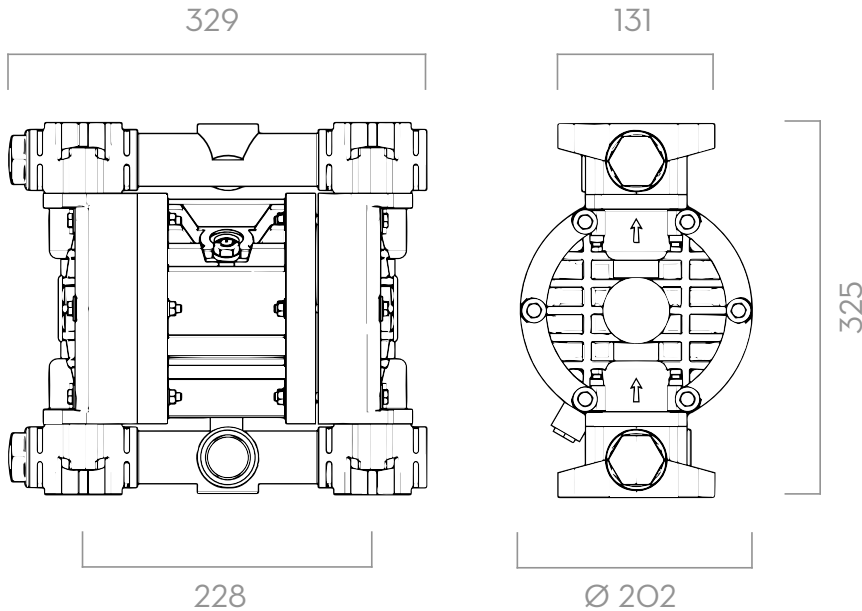

Dimensions expressed in millimeters

TECHNICAL DATA

CODE	DESCRIPTION	FLUIDS TYPE	PUMP BODY	IN / OUT	FLOW RATE L/MIN	MEMBRANE TYPE	DIAPHRAGM	BALLS	BALL SEATS*	O-RING*	INTAKE / DELIVERY CONNECTION	AIR CONNECTION	MAX SELF-PRIMING CAPACITY	MAX HEAD**	MAX AIR SUPPLY PRESSURE	MAX Ø OF PASSING SOLID
FOO208A10	PIUSI MA 180	O D	ALLUMINIUM	1" G	150	SINGLE	NBR	NBR	PPS-V	NBR	G 1" F	G 3/8" F	5	70	7	4

(*) ON REQUEST WE CAN PROVIDE MEMBRANES, BALLS, BALL SEATS AND O-RINGS IN DIFFERENT MATERIALS.
 (**) THE VALUE DEPENDS ON THE CONFIGURATION OF THE PUMP

MA 180