

Lacquer Conversion Kit 17L305 & 17J873

312933E

EN

For converting sprayers to spray lacquer materials.



Important Safety Instructions

Read all warnings and instructions in this manual and in the sprayer operation manual. Save these instructions.

Refer to the illustrations in this document and your Owners/Operation manual for additional parts information, wiring diagrams, and any additional assembly torques that you may need.

Pressure Relief Procedure

Before servicing the sprayer, pump pressure must be relieved.



WARNING

SKIN INJECTION HAZARD: This sprayer builds up an internal pressure of 3000 psi (20.7 MPa, 207 bar) during use. This equipment stays pressurized until pressure is manually relieved. Follow this **Pressure Relief Procedure** whenever you stop spraying and before cleaning, checking, servicing, or transporting equipment to prevent serious injury.

1. Turn ON/OFF switch to the **OFF** position.
2. Engage the trigger lock. Always engage the trigger lock when sprayer is stopped to prevent the gun from being triggered accidentally.
3. Turn pressure control to lowest setting.
4. Put drain tube into a pail and place Prime/Spray valve in **PRIME** position (drain) to relieve pressure.
5. Hold the gun firmly to a pail. Point gun into pail. Disengage the trigger lock and trigger the gun to relieve pressure.
6. Engage the trigger lock.
7. If you suspect the spray tip or hose is clogged or that pressure has not been fully relieved:
 - a. **VERY SLOWLY** loosen the spray tip guard retaining nut or the hose end coupling to relieve pressure gradually.
 - b. Loosen the nut or coupling completely.
 - c. Clear airless hose or spray tip obstruction.

Magnum ProX Lacquer Conversion Kits 17L305

To convert a sprayer to spray lacquer materials several O-rings, suction tube, and Prime/Spray (drain) valve must be replaced.

To spray lacquers and other solvent-based flammable material with the ProX17 (17G177, 17G178), ProX19 (17G179, 17G180), ProLTS170 (17H198) or ProLTS190 (17H206) sprayers, you must install a lacquer conver-

sion kit and follow the **Static Grounding Instructions (Oil-Based materials)** in your Owners/Operation manual.

1. Perform **Pressure Relief Procedure**, on page 1.
2. Unplug sprayer.
3. Follow the instructions in this section to replace the components provided in this kit.

Ref.	Torque
⚠1	140-160 in-lb (16 - 18 N•m)
⚠2	270-330 in-lb (30 - 37 N•m)
⚠3	30-35 in-lb (3.4 - 4.0 N•m)
⚠4	220-250 in-lb (25 - 28 N•m)
⚠5	320-380 in-lb (36 - 43 N•m)

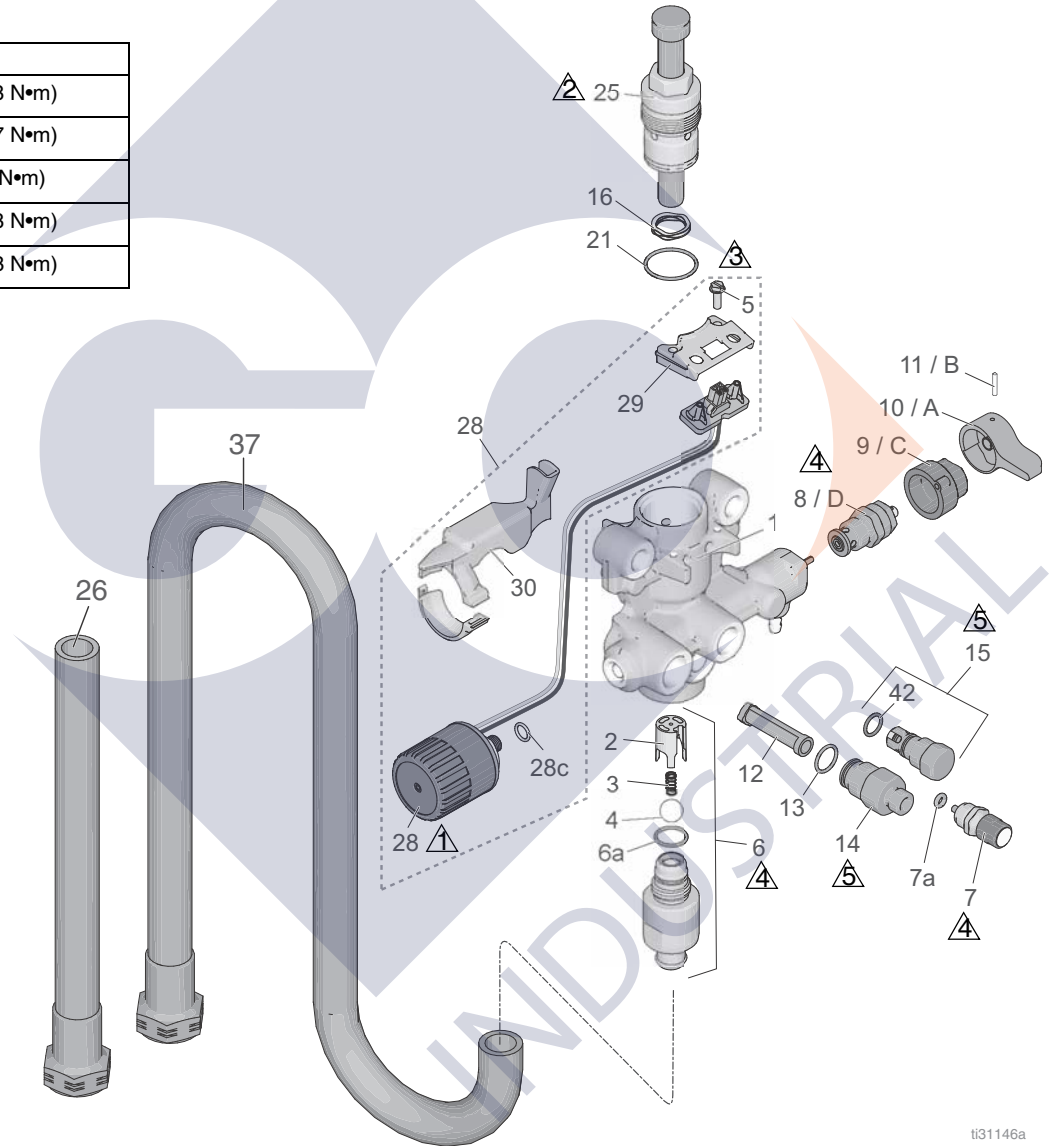

t31146a

Ref. Part	Description	Qty.	For replacement instructions see.
6a 124582	O-ring	1	Replace Pump Inlet Valve O-ring page 3
7a 16P303	O-ring	1	Replace PushPrime Button O-ring page 3
8 239913	VALVE, drain, assy	1	Prime/Spray Valve Replacement page 4
13 120776	O-ring	1	Replace Pump Filter Housing O-ring page 5
21 16D531	O-ring	1	Replace Pump Packing O-ring , on page 5
26 15D883	Tube, suction	1	Suction Tube Replacement page 6
28c 111316	O-ring	1	Replace Pressure Control O-ring , on page 3
37 17D155	Tube, suction	1	Suction Tube Replacement page 6
42 118594	O-ring	1	Replace Pump Outlet Valve O-ring page 5

Pump Assembly Removal

1. Perform **Pressure Relief Procedure**, on page 1.
2. Unplug sprayer.
3. Pull tabs on sides of the easy access door pump towards you while pushing the entire door away from the inlet end of the pump.
4. Now lift the door so that it swivels out of the way.

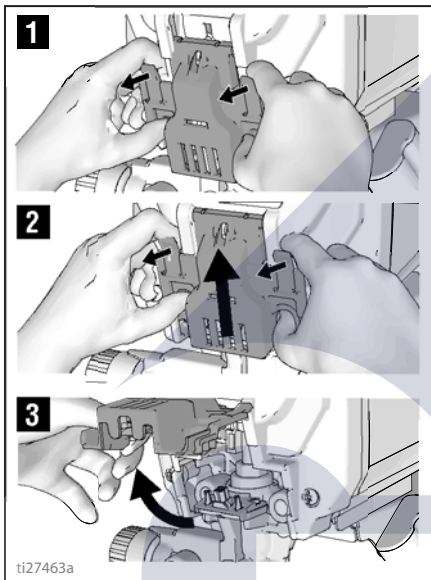

5. Remove pump by sliding it off the mounting pins.
6. Remove wire shield (30).
 - Unsnap the wire shield. On some models a retaining screw must be removed from the pump housing (1).
 - Save wire shield (30).
 - Note the wire routing. Wires on pressure control, must be routed the same way during reassembly.
7. Remove the two screws (5) from electrical connector bracket (29). Save the screws.

Replace Pressure Control O-ring

1. Turn pressure control knob fully counterclockwise to expose the wrench flats. Remove pressure control (28) with wire and electrical connector bracket (29). Verify the O-ring (28c) has been removed from the pump housing (1).
2. Install new O-ring (28c) on the pressure control (28).
3. Apply one or two drops of thread locking adhesive (included in kit) to threads of pressure control (28). Assemble pressure control (28) into pump housing (1) and torque. See page 2 for torque.

Replace Pump Inlet Valve O-ring

Disassembly

1. Remove suction tube. Hopper may need to be removed on models with a hopper.
2. Remove inlet valve fitting (6) from pump housing (1). Remove O-ring (6a). Make certain inlet ball (4), spring (3), and ball guide (2) are removed from pump housing (1).
3. Clean all dried residue from around pump inlet sealing area in pump housing (1).

Assembly

1. Assemble ball guide (2), spring (3), and ball (4) into pump housing (1).
 - a. The ball guide (2) is keyed for proper alignment.
 - b. Make certain the bump on the ball guide (2) is aligned with the slot in the pump housing (1). Slide ball guide (2) into pump housing (1).
 - c. Install spring (3) over ball stop pin in the ball guide (2).
 - d. Install ball (4) into ball guide (2).
2. Install new O-ring (6a) on inlet valve housing (6).
3. Thread inlet valve housing (6) into pump housing (1) and torque. See page 2 for torque.
4. Use a pencil or similar object to push on the ball (4) through the inlet valve intake to make sure the ball moves free.

Replace PushPrime Button O-ring

1. Remove PushPrime button (7) from pump housing (1).
2. Clean all dried residue from around PushPrime button sealing area in pump housing (1).
3. Install new O-ring (7a) on the PushPrime button (7).
4. Thread PushPrime button (7) into pump housing (1) and torque. See page 2 for torque.

Prime/Spray Valve Replacement

Disassembly

1. Turn knob (A) up to SPRAY position.
2. Remove pin (B) with pin punch and hammer.

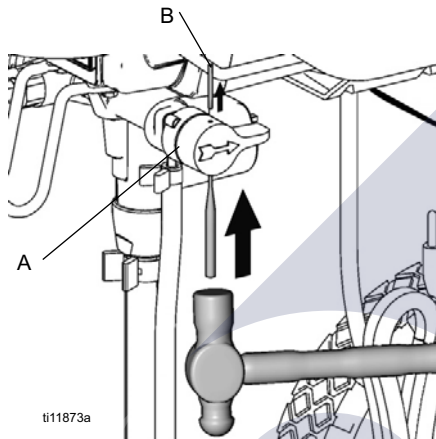

3. Remove knob (A) and base (C).

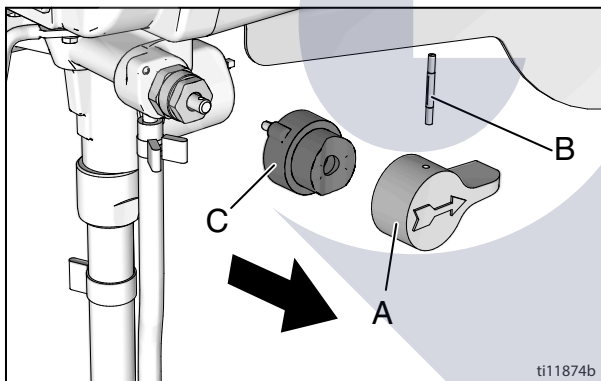

4. Remove valve stem assembly (D) from pump housing (1). Make certain gasket (X) and seat (Z) do not stay in pump housing (1).

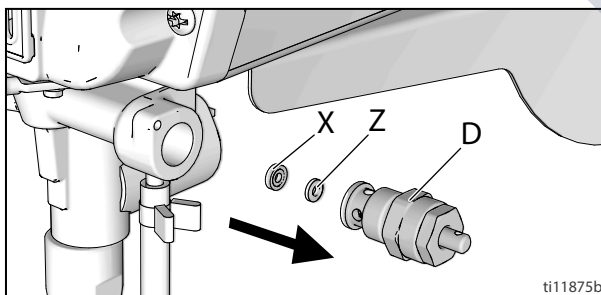

Assembly

5. Apply sealant (provided in kit) to valve threads. Install new valve stem assembly in pump manifold and torque. See page 2 for torque.
6. Install base (C) on valve, aligning pin (E) on base (C) with hole (F) on pump housing (1).

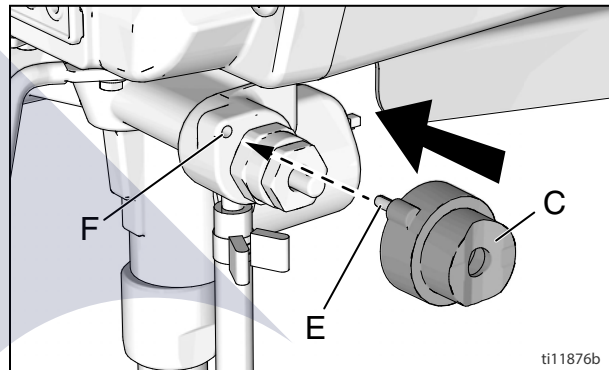

7. Rotate valve stem with a pin punch until hole is perpendicular.

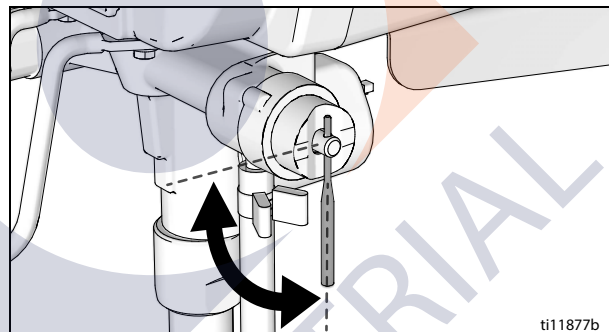

8. Install knob (A) over base (C).
9. Place knob in SPRAY position.
10. Insert end of pin punch through hole in knob (A), to make sure knob and valve stem are aligned.

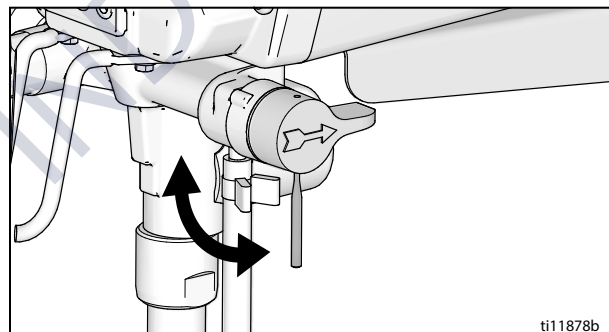

11. Install pin (B) through hole in knob (A). Tap pin through knob with hammer. End of pin will be flush with top of hole in knob when correctly installed.

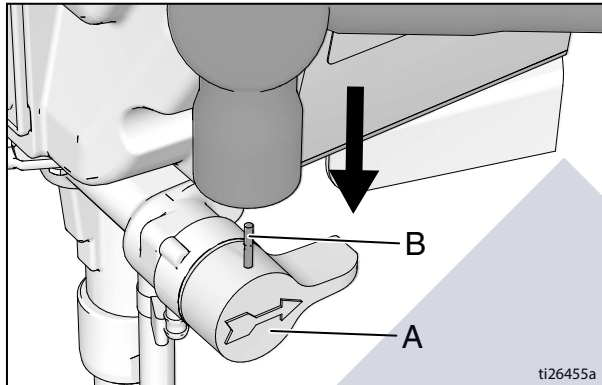

Replace Pump Outlet Valve O-ring

Disassembly

1. Remove outlet valve (15) from pump housing (1). Remove O-ring (42).
2. Clean all dried residue from around pump outlet seat area in pump housing (1).

Assembly

1. Install new O-ring (42).
2. Thread new pump outlet valve (15) into pump housing (1). Torque, see page 2 for torque.

Replace Pump Filter Housing O-ring

Disassembly

1. Remove pump filter housing (14) from pump housing (1). Remove O-ring (13).
2. Clean all dried residue from around pump filter housing area in pump housing (1).

Assembly

1. Install new O-ring (13).
2. Thread pump filter housing (14) into pump housing (1). Torque, see page 2 for torque.

Replace Pump Packing O-ring

Remove pump packing assembly (25) and replace O-ring (21) with new one.

1. Insert hex end of pump into hex tool in the sprayer frame and turn counter-clockwise to loosen assembly. Location of the hex varies depending on the sprayer.

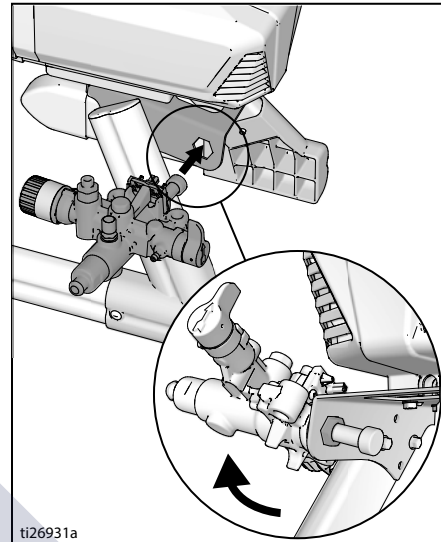

2. Remove entire packing assembly (25) from pump housing (21) including the packing spring (16).
3. Remove and replace O-ring (21).

NOTICE

Be careful not to lose the packing spring that is installed on the pump rod. Operation without the packing spring will cause early pump failure.

4. While holding the pump body upside down start threading the new packing assembly in by hand.

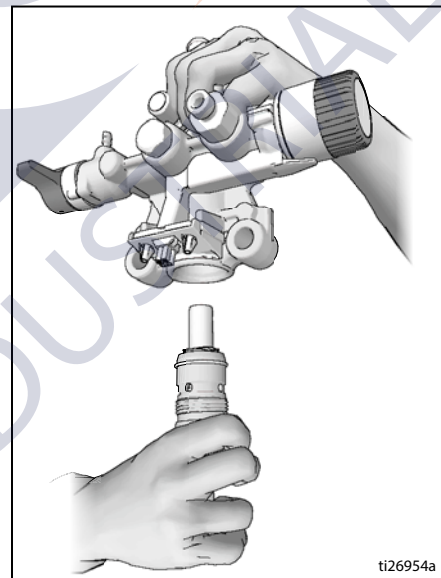

5. Insert hex end of pump into hex tool in the sprayer frame and torque. See page 2 for torque.

Pump Assembly Installation

1. Route wire from pressure control (28) with electrical connector bracket (29) along pump housing (1) to mounting location.
2. Secure electrical connector bracket (29) to pump housing (1) with screws (5) removed earlier and torque. See page 2 for torque.
3. Install wire shield (30).
 - Make certain wire is under wire shield (30).
 - Snap the wire shield around the pump housing (1). On some models, install retaining screw (5) into pump housing (1) and torque. See page 2 for torque.

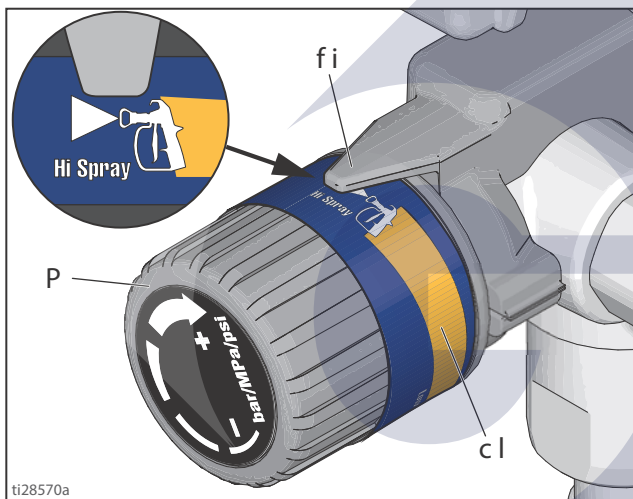

4. Slide pump assembly onto the mounting pins.

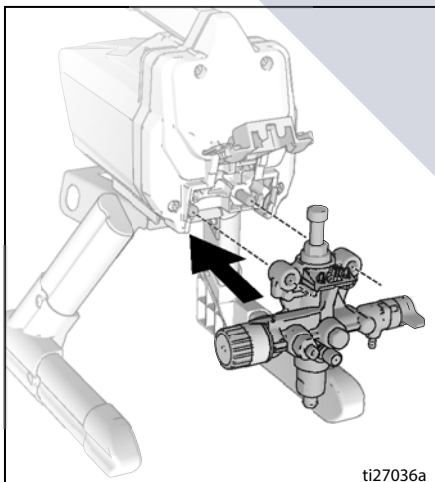

5. Move pump displacement rod up or down until cap is level with the opening in the yoke.

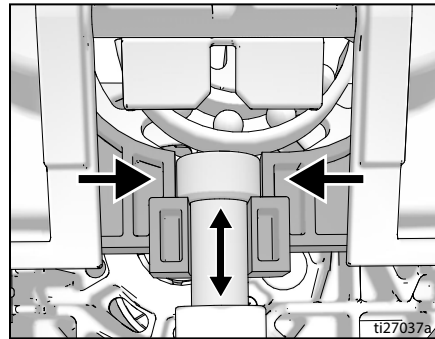

Close Easy Access Door

6. Swing easy access door pump door closed while pushing the entire door towards the inlet end of the pump.

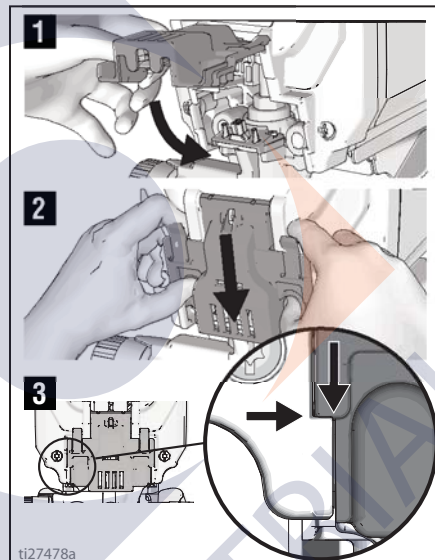

NOTE: Door must be fully closed and latched before sprayer will operate.

Suction Tube Replacement

1. Remove suction tube (26 or 37) from pump inlet.
2. Remove clamp and strainer from suction tube.
3. Locate new suction tube (26 or 37).
4. Install strainer.
5. Slide clamp over the other end of the suction tube.
6. Install suction tube onto pump inlet and secure with clamp.

Lacquer Conversion Kit 17J873

To spray lacquers and other solvent-based flammable material with the ProX7 (261815), ProX9 (261820), ProLTS17 (24N906, 257070) or ProLTS19 (24N808, 257080) sprayers, you must install a lacquer conversion kit and follow the **Static Grounding Instructions (Oil-Based materials)** in your Owners/Operation manual.

Ref.	Part No.	Description	Qty.
1	117559	O-RING, CV-75, size 020	2
2	118594	O-RING, CV-75, size 013	1
3	111316	O-RING, CV-75, size 012	1
4	15D370	O-RING, CV-75, size 022	1
5	120776	O-RING, CV-75, size 015	1
7	119400	SEALANT, pipe, sst	1
8	15D883	TUBE, suction	1
D	239913	VALVE, drain	1

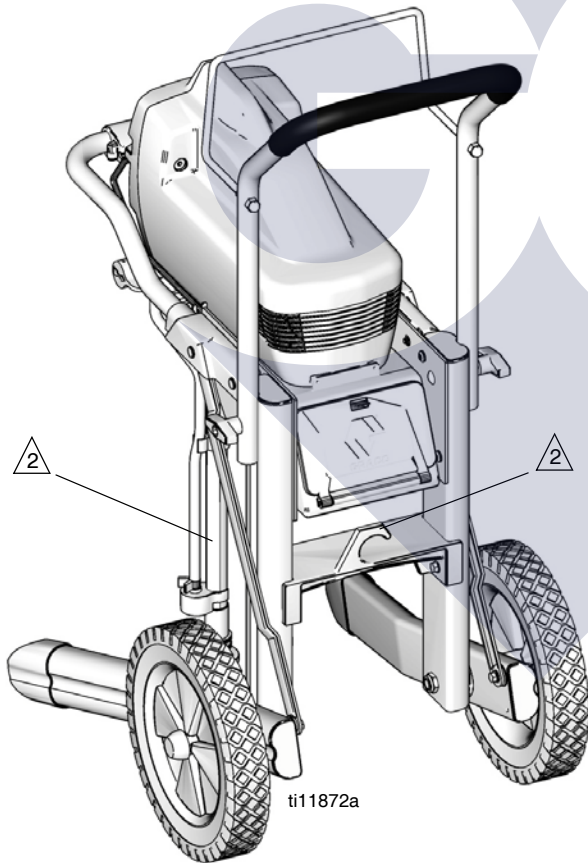

ti11872a

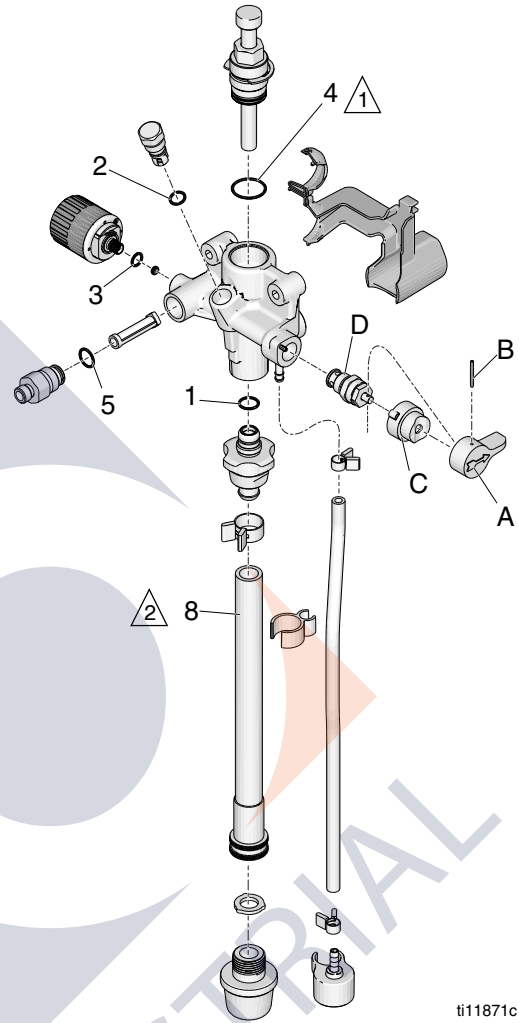

ti11871c

- 1 Apply light coat of lithium-based grease
- 2 Do not use hook storage with new suction tube as it is not flexible enough to allow for bending. Damage will occur.

240V Sprayers Only

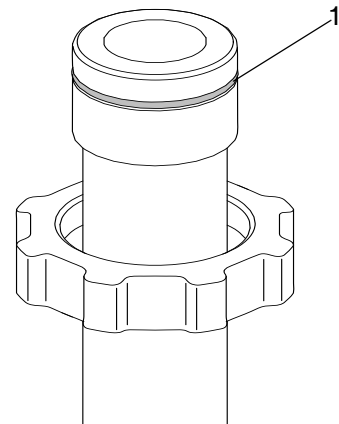

Instructions (17J873)

1. Perform **Pressure Relief Procedure**, on page 1.
2. Turn knob (A) up to **SPRAY** position.
3. Remove pin (B) with pin punch and hammer.

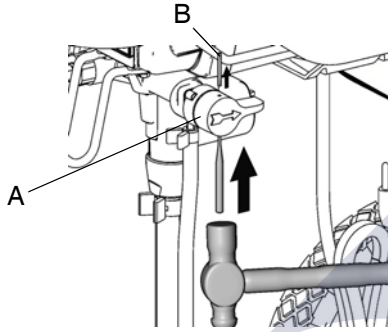

4. Remove knob (A) and base (C).

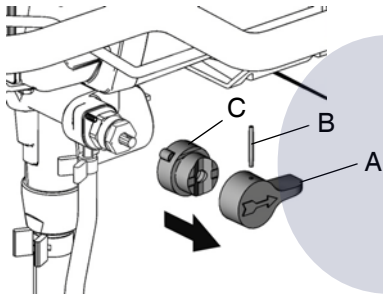

5. Remove valve stem (D) from manifold. Be sure gasket (X) and seat (Z) do not stay in manifold.

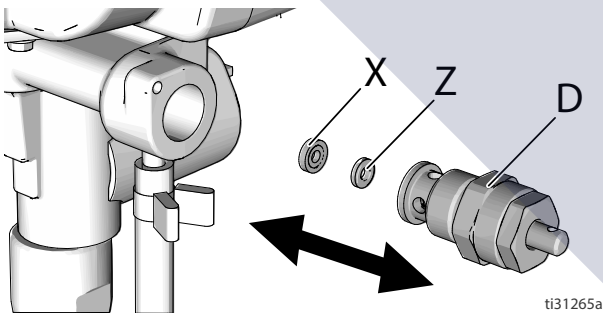

6. Apply sealant (7) to valve threads. Install valve stem (D) in pump manifold. Torque to 185 in-lb (21 N•m).
7. Install base (C) on valve, aligning pin (E) on base (C) with hole (F) on manifold.

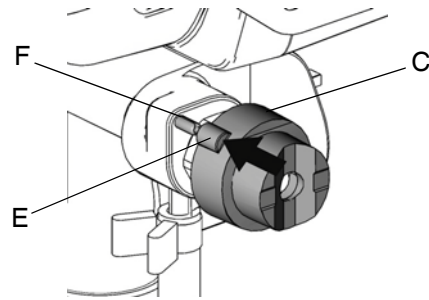

8. Rotate valve stem with a pin punch until hole is perpendicular.

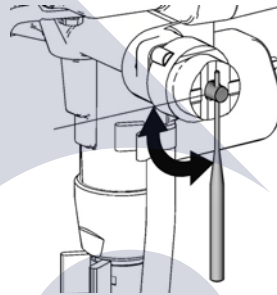

9. Install knob (A) over base (C).

10. Place knob in **SPRAY** position.

11. Insert end of pin punch through hole in knob (A), to make sure knob and valve stem are aligned.

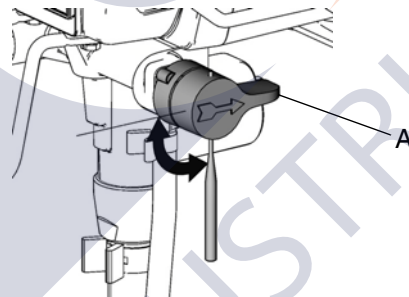

12. Install pin (B) through hole in knob (A). Tap pin through knob with hammer. End of pin will be flush with top of hole in knob when correctly installed.

Graco Information

For the latest information about Graco products, visit www.graco.com

TO PLACE AN ORDER, contact your Graco distributor or call 1-800-690-2894 to identify the nearest distributor.



*All written and visual data contained in this document reflects the latest product information available at the time of publication.
Graco reserves the right to make changes at any time without notice.*

Original instructions. This manual contains English. MM 312933

Graco Headquarters: Minneapolis

International Offices: Belgium, China, Japan, Korea

GRACO INC. AND SUBSIDIARIES • P.O. BOX 1441 • MINNEAPOLIS MN 55440-1441 • USA
Copyright 2008, Graco Inc. All Graco manufacturing locations are registered to ISO 9001.

www.graco.com
Revision E, April 2017