

BORUM

INDUSTRIAL WORKSHOP EQUIPMENT

**INDUSTRIAL
QUALITY**



OWNER'S MANUAL BORUM AIR ACTUATED TRUCK JACK RANGE



PLEASE NOTE:

TO LOWER THE JACK, THE SAME AMOUNT OF FREE AIR FLOW IS REQUIRED AS WHEN LIFTING

WARNING

IMPORTANT: READ ALL INSTRUCTIONS BEFORE USE



WARNING



The instructions and warnings contained in this manual should be read and understood before using or operating this equipment. Do not allow anyone to use or operate this equipment until they have read this manual and have developed a thorough understanding of how this equipment works. Failure to observe any of the instructions contained in the manual could result in severe personal injury to the user or bystanders, or cause damage to the equipment and property. Keep this manual in a convenient and safe place for future reference.

Whilst every effort has been made to ensure accuracy of information contained in this manual, the TQB Brands Pty Ltd policy of continuous improvement determines the right to make modifications without prior warning.

CONTENT

WARNING	2
CONTENT	2
SAFETY INSTRUCTIONS	3
ASSEMBLY, OPERATION, PREVENTITIVE MAINTENANCE	4
TROUBLESHOOTING	12
WARRANTY	13

SAFETY INSTRUCTIONS

 WARNING 	
FAILURE TO READ THESE WARNINGS MAY RESULT IN PROPERTY DAMAGE & PERSONAL INJURY	
<ul style="list-style-type: none"> • Support load by appropriate means after lifting • Do not exceed rated capacity • Centre load on the jack • Only use attachments and/or adapters supplied with or sold specifically for the jack 	<ul style="list-style-type: none"> • Only lift areas of the vehicle designated by the vehicle manufacturer. • Use as lifting device only • Use only on hard, level surface • Do not modify jack



SAFETY OPERATING INSTRUCTIONS

- This jack should be used for lifting and lowering only. The raised load should be supported on approved support stands. No person should get any part of the body under a load that is supported by this jack.
- Position the jack to only lift on the areas of the load specified by the manufacturer.
- Use support stands – after lifting the load always support the load with appropriately rated support stands before working on the load.
- Do not overload this jack beyond its rated capacity. Overloading this jack beyond its rated capacity can cause damage to or failure of the jack.
- Use only on hard level surfaces capable of sustaining the load. Use on other than hard level surfaces can result in jack instability and possible loss of load.
- Centre load on jack saddle before lifting vehicle.
- Off centre loads and loads lifted when the jack is not level can cause loss of load or damage to the jack.
- Keep hands & feet clear of the jack hinge mechanism & ground contact area when lowering the load.
- NEVER LIFT THE LOAD OFF AIRBAG BRACKETS. ALWAYS LIFT OFF AN AXLE OR CHASSIS LIFT POINT

THIS JACK IS A LIFTING DEVICE ONLY & IS DESIGNED FOR LIFTING PART OF THE TOTAL VEHICLE/LOAD. DO NOT MOVE OR DOLLY THE VEHICLE/LOAD WHILST THE VEHICLE/LOAD IS ON THE JACK.

ASSEMBLY, OPERATION, PREVENTITIVE MAINTENANCE

1. FEATURES & MODELS

The BORUM "Industrial Quality" Commercial Jacks are made to TQB Brands specification using quality components that are built to exacting standards through CNC machining and Robotic Welding. The result is top industrial performance and reliability. BORUM "Industrial Quality" Commercial Jacks are the perfect choice for a wide variety of uses. These Commercial Jacks are carefully constructed from the highest grades of rugged steel. The super strong hydraulic pump utilises wear-resistant American Made XTP double sealing ring technology. Only the finest quality of Hydraulic Oil is used that has been tested from -25°C - 60°C.

Use these workhorses with a 145–175psi rated air pressure supply to lighten the load and provide the fast, strong lifting power you need. With several lifting options as well as included saddle adaptors...the wide range of BORUM Commercial Jacks will suit most desired applications from agriculture to mining, earth-moving to passenger transport as well as aviation and military.

FEATURES

- American made seals
- Double Sealing Function using XTP Industry Sealing
- Telescopic air actuation lift (air-hydraulic pump)
- Long T-handle lets you easily position your jack under vehicle
- Self-Returning Lowering and Lifting Switch
- Internal and External Cylinders hard chromed
- High manoeuvrability & deep reach under vehicles
- Extension adaptors / saddle plates
- Large rubber wheels

MODELS

BTJ1530TAM

AIR ACTUATED MOBILE SERVICE JACK 2 STAGE 30,000/15,000KG

- First Stage: 30,000kg Safe Working Capacity
- Second Stage: 15,000kg Safe Working Capacity
- First Stage Hydraulic Lift: 73mm
- Second Stage Hydraulic Lift: 66mm
- Minimum Height: 150mm
- Maximum Height: 490mm
- Adaptors: 45 and 75mm
- Handle Length: 500mm
- Operating Air Pressure: 145-175psi
- Chassis: 500x290x150mm
- Nett Weight: 24kg

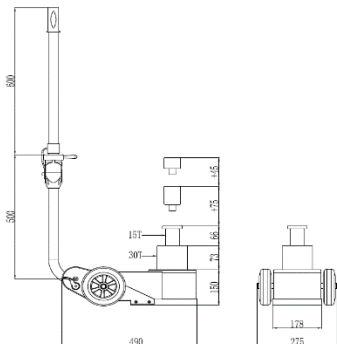

BTJ1530TA

AIR ACTUATED JACK 2 STAGE 30,000/15,000KG

First Stage: 30,000kg Safe Working Capacity
 Second Stage: 15,000kg Safe Working Capacity
 First Stage Hydraulic Lift: 73mm
 Second Stage Hydraulic Lift: 66mm
 Minimum Height: 150mm
 Maximum Height: 409mm
 Adaptors: 45mm and 75mm
 Handle Length: 1300mm
 Operating Air Pressure: 145-175psi
 Chassis: 480x290x150mm
 Nett Weight: 38kg

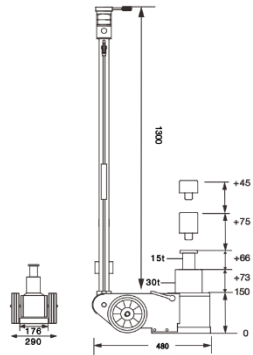

BTJ1025TA

AIR ACTUATED JACK 2 STAGE 10,000/25,000KG

First Stage: 25,000kg Safe Working Capacity
 Second Stage: 10,000kg Safe Working Capacity
 First Stage Hydraulic Lift: 97mm
 Second Stage Hydraulic Lift: 95mm
 Minimum Height: 185mm
 Maximum Height: 497mm
 Adaptors: 45mm and 75mm
 Handle Length: 1380mm
 Operating Air Pressure: 145-175psi
 Chassis: 770x282x185mm
 Nett Weight: 53kg

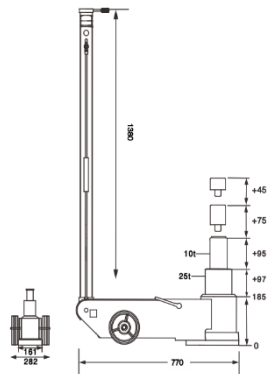

BTJ102550TA

AIR ACTUATED JACK 3 STAGE 10,000/25,000/50,000KG

First Stage: 50,000kg Safe Working Capacity
 Second Stage: 25,000kg Safe Working Capacity
 Third Stage: 10,000kg Safe Working Capacity
 First Stage Hydraulic Lift: 62mm
 Second Stage Hydraulic Lift: 61mm
 Third Stage Hydraulic Lift: 69mm
 Minimum Height: 160mm
 Maximum Height: 472mm
 Adaptors: 45mm and 75mm
 Handle Length: 1380mm
 Operating Air Pressure: 145-175psi
 Chassis: 825x282x160mm
 Nett Weight: 61kg

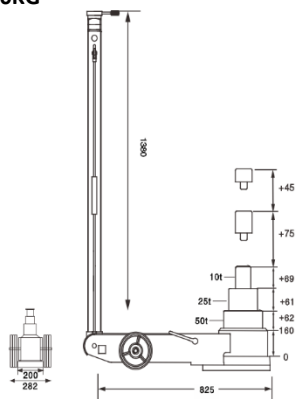

BTJ2550TA

AIR ACTUATED JACK 2 STAGE 25,000/50,000KG

First Stage: 50,000kg Safe Working Capacity
Second Stage: 25,000kg Safe Working Capacity
First Stage Hydraulic Lift: 115mm
Second Stage Hydraulic Lift: 114mm
Minimum Height: 215mm
Maximum Height: 564mm
Adaptors: 45mm and 75mm
Handle Length: 1380mm
Operating Air Pressure: 145-175psi
Chassis: 805x282x215mm
Nett Weight: 73kg

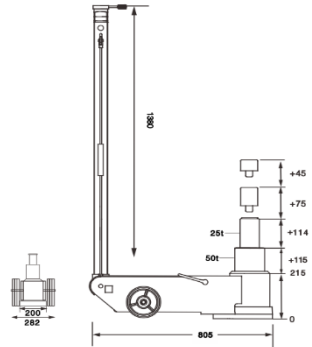

BTJ204060TA

AIR ACTUATED JACK 3 STAGE 60,000/40,000/20,000KG

First Stage: 60,000kg Safe Working Capacity
Second Stage: 40,000kg Safe Working Capacity
Third Stage: 20,000kg Safe Working Capacity
First Stage Hydraulic Lift: 57mm
Second Stage Hydraulic Lift: 59mm
Third Stage Hydraulic Lift: 61mm
Minimum Height: 150mm
Maximum Height: 447mm
Adaptors: 45mm and 75mm
Handle Length: 1380mm
Operating Air Pressure: 145-175psi
Chassis: 875x295x150mm
Nett Weight: 67kg

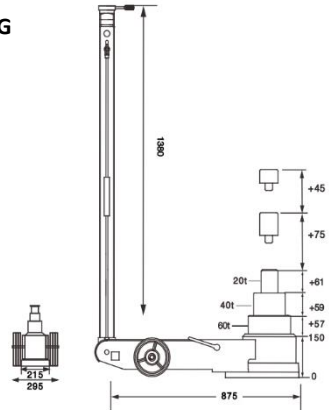

BTJ5080TA

AIR ACTUATED JACK 2 STAGE 50,000/80,000KG

First Stage: 80,000kg Safe Working Capacity
Second Stage: 50,000kg Safe Working Capacity
First Stage Hydraulic Lift: 111mm
Second Stage Hydraulic Lift: 102mm
Minimum Height: 230mm
Maximum Height: 563mm
Adaptors: 45mm and 75mm
Handle Length: 1380mm
Operating Air Pressure: 145-175psi
Chassis: 930x340x230mm
Nett Weight: 106kg

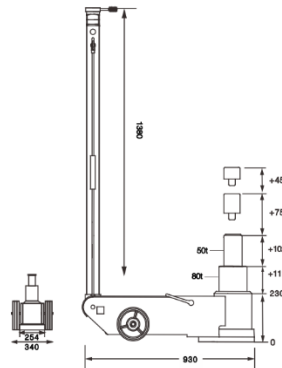

BTJ60TA

AIR ACTUATED JACK HIGH LIFT 60,000KG

Single Stage: 60,000kg Safe Working Capacity

Single Stage Hydraulic Lift: 311mm

Minimum Height: 420mm

Maximum Height: 1031mm

Adaptors: 100mm and 200mm

Handle Length: 1380mm

Operating Air Pressure: 145-175psi

Chassis: 910x360x420mm

Nett Weight: 126kg

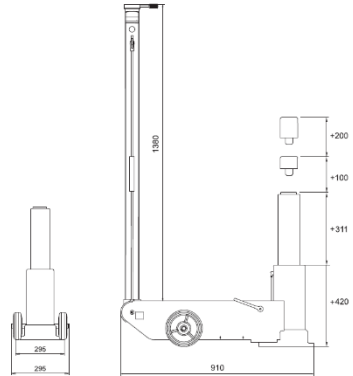

BTJ22TA

AIR ACTUATED JACK 20,000KG

Single Stage: 22,000kg Safe Working Capacity

Hydraulic Lift: 141mm

Minimum Height: 215mm

Maximum Height: 456mm

Adaptors: 20, 50 and 100mm

Handle Length: 1240mm

Operating Air Pressure: 145-175psi

Chassis: 525x265x215mm

Nett Weight: 40kg

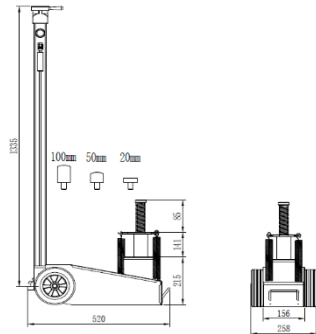

2. ASSEMBLY

Step 1:

Screw toggle (taped to bottom of carton with handle in) into the top of the handle.

Remove axle from rear of jack.

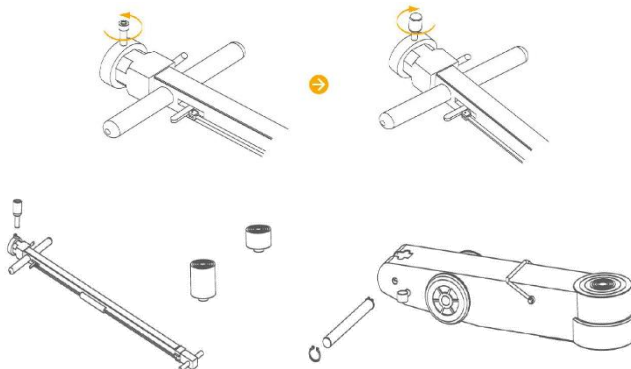

Step 2:

Insert hoses from Handle into rear of jack as pictured below.

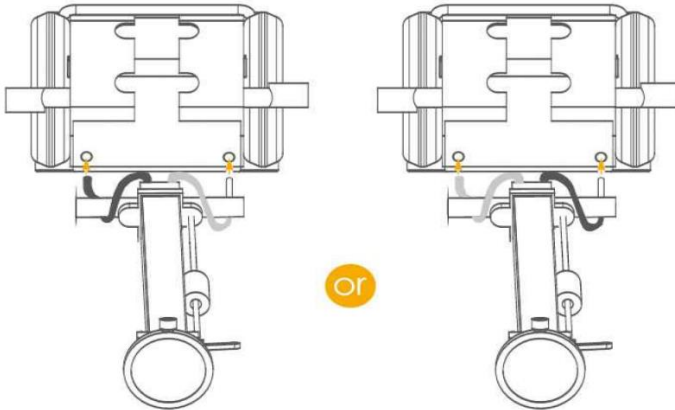

Step 3:

Insert handle base into slot and thread axle through jack and handle.
Lock in place with circlip

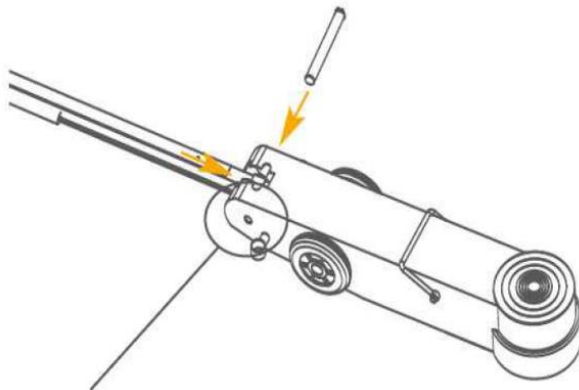

PLEASE NOTE:

TO LOWER THE JACK, THE SAME AMOUNT OF FREE AIR FLOW IS REQUIRED AS WHEN LIFTING

3. BEFORE USE

Prior to each use conduct a visual inspection checking for abnormal conditions, such as cracked welds, leaks, and damaged, loose, or missing parts.

- Consult the vehicle owner's manual to determine the location of lift points.
- Be sure to set the vehicle in park with the emergency brake on and wheels securely chocked.
- Be sure that the vehicle and the jack are on a hard, level surface.

4. OPERATION

1. This jack is equipped with a handle position lock. To adjust the handle, release the lock device by pulling the lever up. The lever is spring loaded so, so it should lock into the desired position.
2. Make sure the jack and load are on a hard level surface.
3. Always set the vehicle parking brake and block the wheels.
4. Check the placement of the jack. The load must be centered on the jack saddle. Avoid jack wheel obstructions such as gravel, tools, or uneven expansion joints.
5. Position the jack under the load using the manufacturer's recommended lifting points on the chassis.
6. Connect compressed air supply to the jack. (Compressed air should be clean, dry, and regulated at 120-170psi). Install an air filter/lubricator in the workshop air-line, because water in the airline will damage the jack.
7. Rotate the lever RIGHT to the UP position. (To stop air operation, simply release the grip on the lift control trigger). Continue to pump the jack until the head cap reaches the load.
8. Before raising the load, double check and verify the saddle is centred and has full contact with the specified lifting point.
9. Rotate the lever RIGHT to the UP position (To stop air operation, simply release the grip on the lift control trigger). Continue to pump the jack to lift the load to the desired height.
10. Always immediately position approved support stands under the load at points that will provide stable support in accordance with the vehicle or load manufactures recommendations.
11. Always lower the load slowly onto the support stands by rotating the lever LEFT to the DOWN position.
12. Carefully lower the load onto the support stands by rotating the lever to the DOWN position

Lowering the load

1. Raise the load by following Steps 2-9
2. Raise the load high enough to allow clearance for the support stands to be removed by rotating the lever to the Right UP position.
3. Carefully remove the support stands
4. Grasp the jack handle firmly. Securely hold onto the jack handle so that your hands do not slip and ensure the release valve does not lower rapidly.
5. Carefully open the release valve by slowly rotating the LEVER to the LEFT DOWN position.
6. Once the load has been lowered, remove the jack from beneath the load, and fully retract the ram to prevent exposure to dirt and grime.

5. INSPECTION

- Prior to each use conduct a visual inspection checking for abnormal conditions, such as cracked welds, leaks, and damaged, loose, or missing parts.
- The jack shall always be maintained in accordance with the maintenance instructions (Section 7). No alterations or modifications shall be made to this Jack.
- Inspections shall be performed in accordance with this owner's manual.
- The jack must be inspected immediately if it is believed to have been subjected to abnormal load or shock.
- Owners and /or operators should be aware that repair of this product may require specialised equipment and knowledge (refer to maintenance section).

6. STORAGE

This jack should always be stored in a dry location on a level surface with the lift ram pistons in the fully retracted position, where it will not be exposed to corrosive vapours, abrasive dust, or any other harmful elements.

7. MAINTENANCE

Monthly maintenance is recommended. Lubrication is critical to jacks as they support heavy loads. Any restriction due to dirt, rust, etc, can cause either slow movement or cause extremely rapid jerks damaging the internal components. The following steps are designed to keep the jack well maintained and operational.

Important: Dirt is the greatest single cause of failure in hydraulic units. Keep the jack clean and well lubricated to prevent foreign matter from entering the system. If the jack has been exposed to rain, snow, sand, or grit it must be cleaned before it is stored or used.

- Only use replacement parts that are approved by the manufacturer. Disconnect the air supply before performing any maintenance operation.
- Lubricate the ram, linkages, saddle, wheels and pump mechanism with light Hydraulic oil.
- Visually inspect for cracked welds, bent, loose, missing parts or hydraulic oil leaks.
- Any hydraulic jack found to be damaged, worn or operates abnormally must be removed from service until repaired by an authorised service representative.
- Regularly clean all surfaces and maintain all labels and warnings.
- Check and maintain the hydraulic ram oil level.
- Check the ram every three months for any sign of rust or corrosion. Clean as needed and wipe with a clean oily cloth. When not in use always leave the saddle and ram all the way down.
- Always store your jack in the fully retracted position. This will help protect critical areas from corrosion. Do not use brake or transmission fluids or regular motor oil as they can damage the seals.

ONLY USE HIGH QUALITY HYDRAULIC FLUID – ISO68

8. SERVICE & REPAIR

Any jack found damaged in any way, or found to be worn or operates abnormally should be removed from service until repaired by an authorised service agent. Owners and / or operators should be aware that repair of this product may require specialised equipment and knowledge. Only authorised parts, labels, decals shall be used on this equipment. Annual inspection of the jack is recommended and can be made by an authorised repair facility to ensure that your equipment is in optimum condition and that the equipment has the correct decals and safety labels specified by the manufacturer.

TROUBLESHOOTING

PROBLEM	POSSIBLE CAUSE	ACTION
Jack will not lift	Control valve in wrong position. Low/no oil in reservoir. Air-locked system. Load is above capacity of jack. Delivery valve and/or bypass valve not working correctly. Seals worn out or defective. Not enough air pressure	<i>Turn control valve knob clockwise. Fill with oil and bleed system. Bleed system. Use correct equipment. Clean to remove dirt or foreign matter. Replace oil. Install appropriate seal kit. Ensure constant air delivery of above 120psi</i>
Jack lifts only partially	<ul style="list-style-type: none"> • Too much or not enough oil 	<ul style="list-style-type: none"> • <i>Check oil level</i>
Jack advances slowly	<ul style="list-style-type: none"> • Pump not working correctly • Leaking seals 	<ul style="list-style-type: none"> • <i>Install seal kit, or replace power unit</i> • <i>Install seal kit</i>
Jack lifts load, but doesn't hold	<ul style="list-style-type: none"> • Cylinder packing is leaking • Valve not working correctly (suction, delivery, release or bypass). • Air-locked system 	<ul style="list-style-type: none"> • <i>Install seal kit</i> • <i>Inspect valves. Clean and repair seat surfaces</i> • <i>Bleed system as per instructions</i>
Jack leaks oil	<ul style="list-style-type: none"> • Worn or damaged seals 	<ul style="list-style-type: none"> • <i>Install seal kit</i>
Jack will not retract	<ul style="list-style-type: none"> • Control valve in wrong position • Air Pressure to low 	<ul style="list-style-type: none"> • <i>Move Control valve to DOWN position</i> • <i>Ensure constant air delivery of above 120psi</i>
Jack retracts slowly	<ul style="list-style-type: none"> • Cylinder damaged internally 	<ul style="list-style-type: none"> • <i>Send jack to authorised service centre</i>

PLEASE NOTE:

TO LOWER THE JACK, THE SAME AMOUNT OF FREE AIR FLOW IS REQUIRED AS WHEN LIFTING

WARRANTY

BORUM products have been carefully tested and inspected before shipment and are guaranteed to be free from defective materials and workmanship for a period of 12 months from the date of purchase except where tools are hired out when the guarantee period is ninety days from the date of purchase.

Should this piece of equipment develop any fault, please return the complete tool to your nearest authorised warranty repair agent or contact TQB Brands Pty Ltd Warranty team – warranty@tqbbrands.com.au.

If upon inspection it is found that the fault occurring is due to defective materials or workmanship, repairs will be carried out free of charge. This guarantee does not apply to normal wear and tear, nor does it cover any damage caused by misuse, careless or unsafe handling, alterations, accident, or repairs attempted or made by any personnel other than the authorised TQB Brands Pty Ltd repair agent.

This guarantee applies in lieu of any other guarantee expressed or implied and variations of its terms are not authorised.

Your TQB Brands Pty Ltd guarantee is not effective unless you can produce upon request a dated receipt or invoice to verify your proof of purchase within the 12month period.

Consumer Guarantee

Our goods come with a guarantee that cannot be excluded under the Australian Consumer Law. You are entitled to a replacement or refund for a major failure and compensation for any other reasonably foreseeable loss or damage. You are also entitled to have the goods repaired or replaced if the goods fail to be of acceptable quality and the failure does not amount to a major failure.

