



FILL-RITE®

The Most Trusted Name in Pumps and Meters

NX25-DDC SERIES TECHNICAL SPECIFICATIONS

Motor

Power - DC 12, 24, 12/24	12 to 24 VDC
HP (Horsepower) Rating	1/3 HP
Power Cord Length	20'
Power Cord Gauge (AWG)	10 AWG
DC Power Cord Connectors	Clips not included
Amps (FLA)	30 - 15
RPM	Variable 400 - 3500
Duty Cycle	Continuous for fuel transfer
Thermal Protection	Electronically Protected
Circuit Protection Fuse	Yes (35 AMP)
Certifications	UL/cUL Listed, ATEX, IECEx, CE

Pump

Type / Design	Rotary Vane
GPM in Supplied Configuration	24.5 GPM / 91 LPM*
GPM Open Flow - no Hose or Nozzle	25.8 GPM / 95 LPM*
By-Pass Pressure Rating (PSI) - Max	21 PSI
Dry Vac (in Hg)	11
Head - Max	48'
Inlet - Size / Thread	1 - 1/4" NPT (BSPT available)
Anti-siphon valve	1/4" NPT
Outlet - Size / Thread	1" NPT (BSPP available)
Mount	Cast Iron
Material - Pump Housing	Cast Iron
Material - Wetted Material	BUNA-N + Fluorocarbon
Rotor Material	Powdered Iron
Rotor Vane Material	Acetal
Compatible Fluids	Diesel, Gasoline, Bio-Diesel up to B20, E15, Kerosene
Strainer Mesh Size	20 x 20
Warranty	Limited Lifetime Warranty†

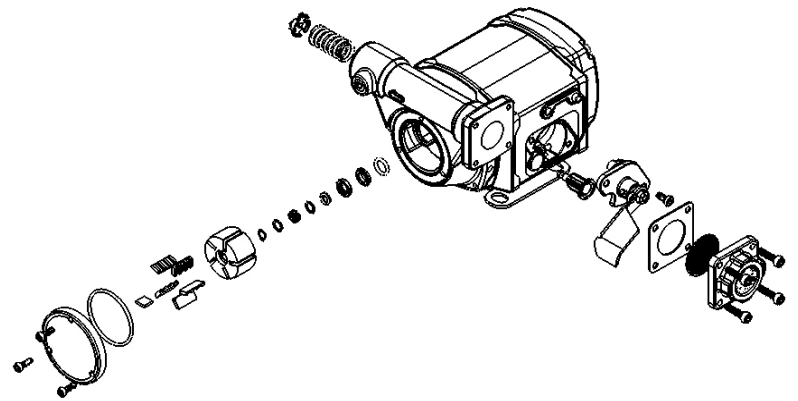

SERVICE KIT INFORMATION

Kit	Description	Parts
KIT321RK	Overhaul Kit	Rotor, rotor cover, vanes, o-ring seal, shaft seal kit, bypass valve, inlet seal & screen, rotor key, attaching hardware
KIT321RG	Rotary Group	Rotor, vanes, rotor key, gasket, rotor cover, screws
KIT320SL	Shaft Seal	8 piece assembly
KIT321BV	Bypass Kit	Poppet, spring, o-ring, cap
KIT321NB	Boot Kit	Nozzle boot, attaching hardware
KIT321SK	External Seal Kit	Rotor cover o-ring seal, inlet gasket, screen
KIT321BG	Inlet Kit	Inlet bung adapter, attaching hardware, inlet screen, seal
KIT321SW	Switch / Breaker	Switch Assembly
KIT321PC	Power Cord	20' Power cord with threaded sleeve attachment and o-ring seals
KIT321FLG	Meter Flange Kit	900CD Meter Flange, attaching hardware

*Adding accessories will affect flow rate

† Warranty details can be found at fillrite.com

DIMENSIONAL INFORMATION

All measurements are in inches [millimeters].

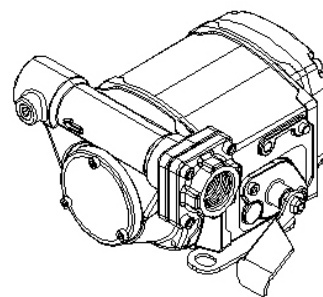
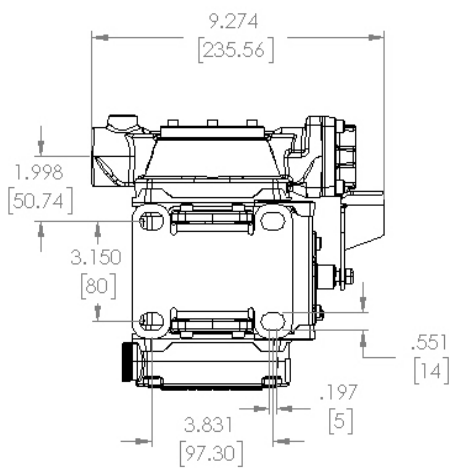
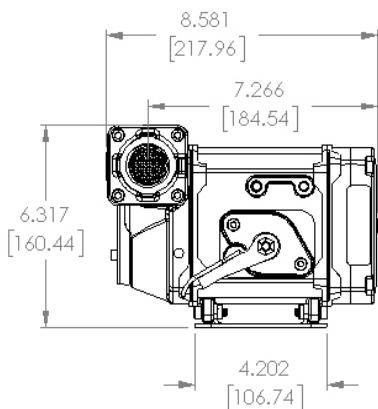
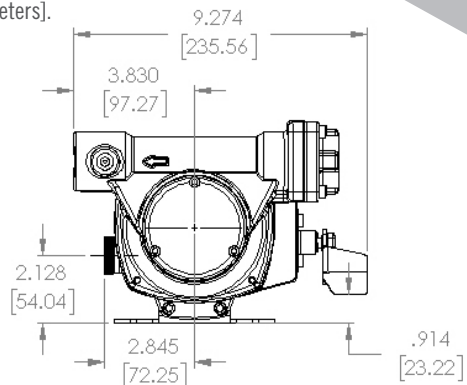
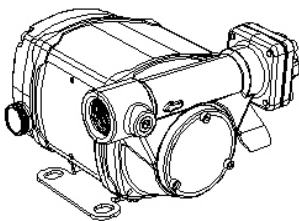
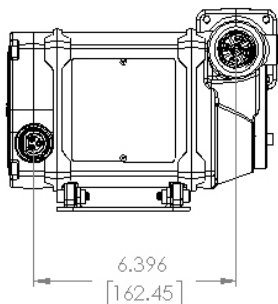

Measurements

Overall Height	6.3"
Overall Width	9.3"
Overall Depth	8.6"
Shipping Weight	26 lbs
Qty per Pallet	16
Box Dimensions (LxWxH)	18" x 15.5" x 10"

Included Accessories

Nozzle - Size	1" NPT-F inlet, 1 1/8" OD spout
Nozzle	Automatic Ultra Hi-Flow
Hose Diameter	1"
Hose Length	18'
Hose Material of Construction	Neoprene exterior
Hose Static Wire (Yes/No)	Yes

PERFORMANCE CURVE: NX25-DDC SERIES

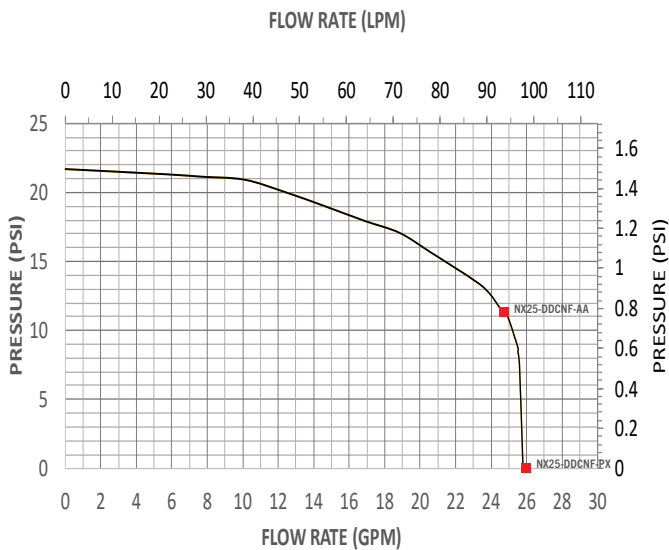

NX25-DDC Pump Models