

## 800 Series Nozzle

Our 800 Series refuelling nozzles are the natural choice for most high flow, industrial diesel filling applications.

They incorporate automatic shut-off functionality when installed with correctly matched receivers and tank vents, and are suitable for use with diesel fuel.

The 800 Series connects with the most commonly encountered Dry Break receiver size. It is therefore completely interchangeable with other equipment brands, simplifying the process of upgrading to a Banlaw solution.

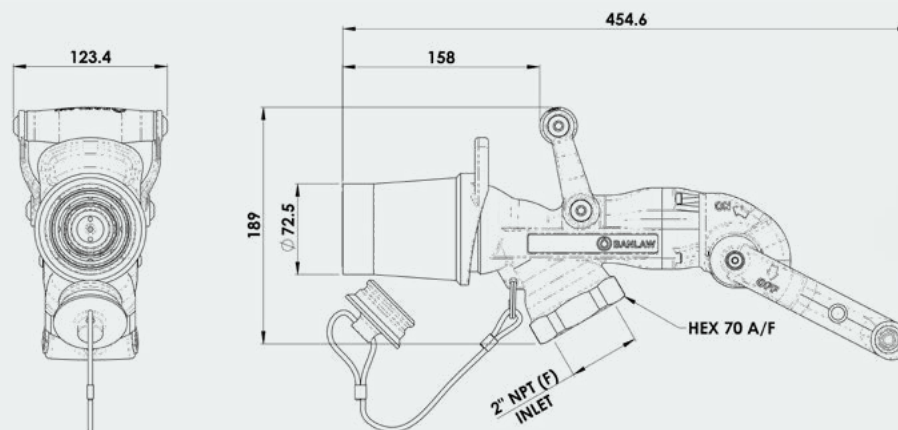

BNM800M

Note: Our Rail and Hydraulic Nozzles will only couple with matched Rail or Hydraulic Receivers. Rail products are specific to that industry.

Part Number	Product Description	Tech Specs	Shipping - Dimensions & Weight	Items Included
BAMS5	800lpm Series Diesel Refuelling Nozzle - Bulk Fill	* 2" NPTF	27x16x12cm   2.25kg	Includes Plug
BARS5	800lpm Series Diesel Refuelling Nozzle - Rail Bulk Fill	* 2" NPTF	27x16x12cm   2.35kg	Includes Plug
BAHS5	800lpm Series Diesel Refuelling Nozzle - Hydraulic Bulk Fill	* 2" NPTF	27x16x12cm   2.25kg	Includes Plug
BNM800L	800lpm Series Diesel Refuelling Nozzle - Light Spring Setting	2" NPTF, LT	48x20x12cm   3.9kg	Includes Plug
BNM800ML	800lpm Series Diesel Refuelling Nozzle - Medium/Light Spring Setting	2" NPTF, MED LT	48x20x12cm   3.9kg	Includes Plug
BNM800M	800lpm Series Diesel Refuelling Nozzle - Medium Spring Setting	2" NPTF, MED	48x20x12cm   3.9kg	Includes Plug
BNM800MH	800lpm Series Diesel Refuelling Nozzle - Medium/Heavy Spring Setting	2" NPTF, MED HVY	48x20x12cm   3.9kg	Includes Plug
BNM800H	800lpm Series Diesel Refuelling Nozzle - Heavy Spring Setting	2" NPTF, HVY	48x20x12cm   3.9kg	Includes Plug
BNR800L	800lpm Series Diesel Refuelling Nozzle - Light Spring Setting - RAIL	2" NPTF, LT	48x20x12cm   3.9kg	Includes Plug
BNR800ML	800lpm Series Diesel Refuelling Nozzle - Medium/Light Spring Setting - RAIL	2" NPTF, MED LT	48x20x12cm   3.9kg	Includes Plug
BNH800L	800lpm Series Diesel Refuelling Nozzle Hydraulic - Light Spring Setting	2" NPTF, LT	48x20x12cm   3.9kg	Includes Plug
BNH800M	800lpm Series Diesel Refuelling Nozzle Hydraulic - Medium Spring Setting	2" NPTF, MED	48x20x12cm   3.9kg	Includes Plug
BNM800L-CT	800lpm Series Diesel Refuelling Nozzle - Light Spring Setting - Cold Temp	2" NPTF, LT	48x20x12cm   3.9kg	Includes Plug ❄️
BNM800ML-CT	800lpm Series Diesel Refuelling Nozzle - Medium/Light Spring Setting - Cold Temp	2" NPTF, MED LT	48x20x12cm   3.9kg	Includes Plug ❄️
BNM800M-CT	800lpm Series Diesel Refuelling Nozzle - Medium Spring Setting - Cold Temp	2" NPTF, MED	48x20x12cm   3.9kg	Includes Plug ❄️
BNM800MH-CT	800lpm Series Diesel Refuelling Nozzle - Medium/Heavy Spring Setting - Cold Temp	2" NPTF, MED HVY	48x20x12cm   3.9kg	Includes Plug ❄️
BNM800H-CT	800lpm Series Diesel Refuelling Nozzle - Heavy Spring Setting - Cold Temp	2" NPTF, HVY	48x20x12cm   3.9kg	Includes Plug ❄️

\* No automatic shut off