

## Remote Breather 3µm

Our Remote Tank Breather prevents damaging airborne contaminants from entering fuel tanks and other fluid storages. It is unique in that it vents at 1,000lpm, and also filters incoming air at 1,000lpm (35.3scfm of air).

This product is perfect for service truck bulk storages, and other tanks where incoming air needs to be filtered at a high rate due to service fluids or diesel being rapidly dispensed from the tank.

- ▶ Compatible with Banlaw and other-brand unfiltered vents
- ▶ Compatible with Banlaw Venting Level Sensor (overflow protection system component)
- ▶ Supports refuelling at 1,000lpm
- ▶ Filters incoming air at up to 1,000lpm
- ▶ 3µm (abs.) filter canister

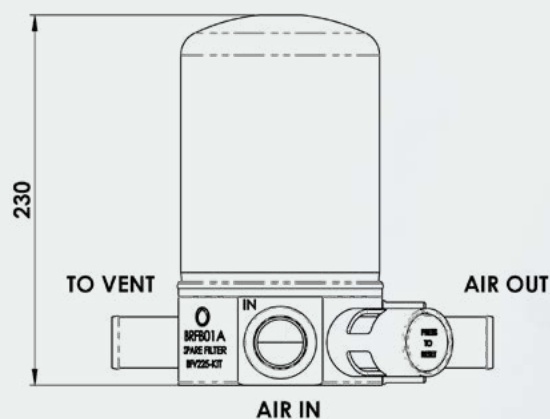
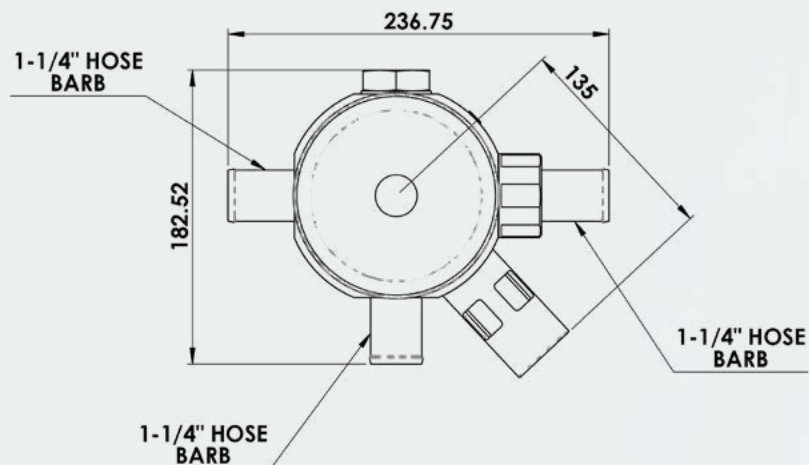

BRFB01A

Note: Filtration of inwards tank air of 4micron abs. or better is recommended by major OEM's of engines used on plant equipment.

Part Number	Product Description	Tech Specs	Shipping - Dimensions & Weight
BRFB01A	Remote Filtered Breather, 3µm (abs.) 1" BSP/1-14" Hose Barb	1" BSPFF	23x23x20cm   3.5kg