

1 LEAK FREE

- Tie-bolt design ensures chemical containment
- Precision fit, machined design

3 PARALLEL PILOT SHIFTING

- Ease of maintenance
- Stall-free design
- Reduced icing air system

5 FIELD SERVICEABLE

- Replaceable air motor, diaphragms, checks and pilot valve

2 CORROSION-RESISTANCE

- 100% PTFE and PE fluid paths
- No exposed metals

4 LONG DIAPHRAGM LIFE

- Enhanced PTFE overmolded diaphragm improves life

6 POSITIVE SEAT-CHECK

- Improves pump performance and suction lift
- Reduces required maintenance

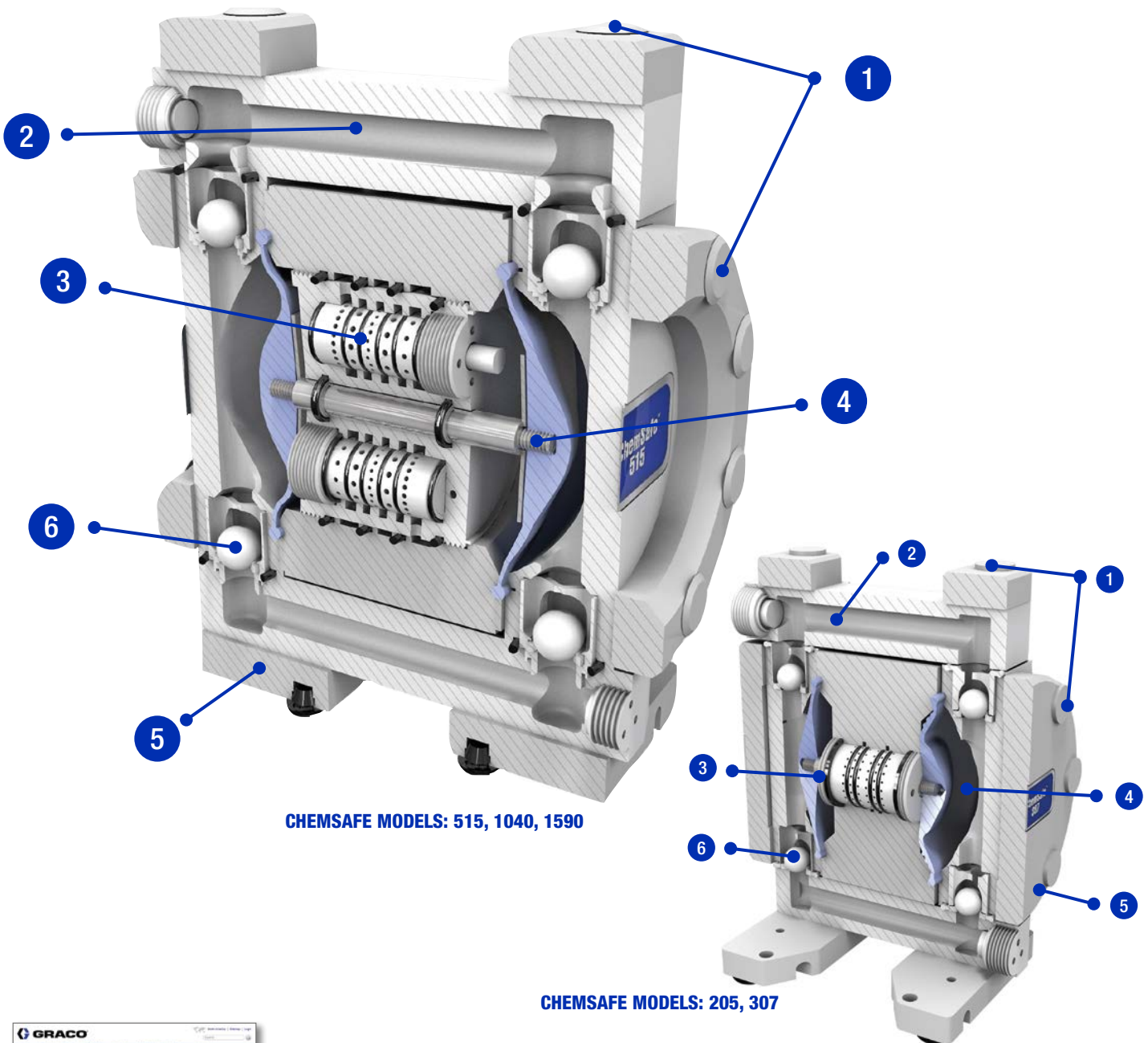

CHEMSAFE MODELS: 515, 1040, 1590

CHEMSAFE MODELS: 205, 307

CHEMICAL COMPATIBILITY GUIDE

Go to our Chemical Compatibility Guide at www.graco.com/chemicalcomp to see if the chemical you want to transfer is compatible with our ChemSafe Pumps.