

HURRICANE™+ LITE TRAILER



4400 - 5080
300-350 BAR
PSI

33 - 36
L/PM

VANGUARD
EFI V-TWIN
PETROL
ENGINE TYPE
VANGUARD

200L
WATER TANK
CAPACITY

SINGLE
AXLE

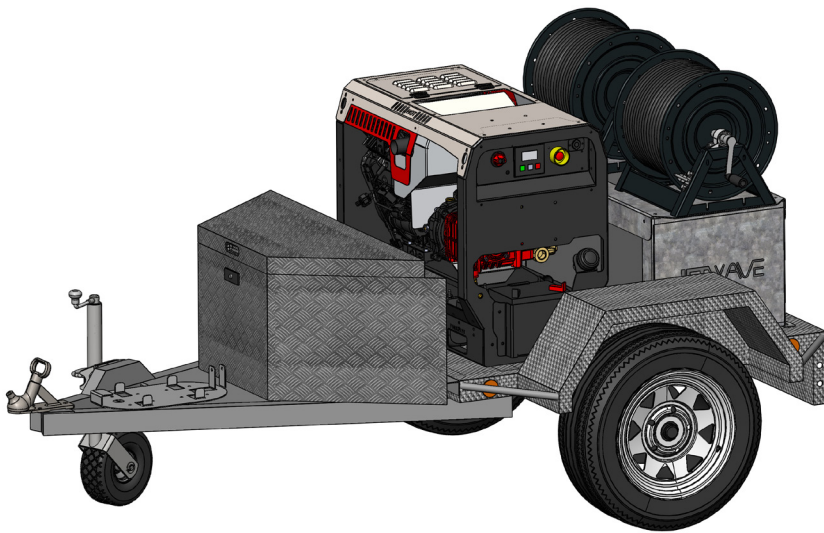

HERO INNOVATIONS

- TURN KEY SOLUTION**
Quality assured and ready to work
- PURPOSE BUILT**
Built for high pressure water equipment
- AUSTRALIAN MADE**
Made for tough Australian conditions



APPLICATIONS

- Portable Drain Cleaning
- Council & Municipality
- Plumbers
- Water Authorities

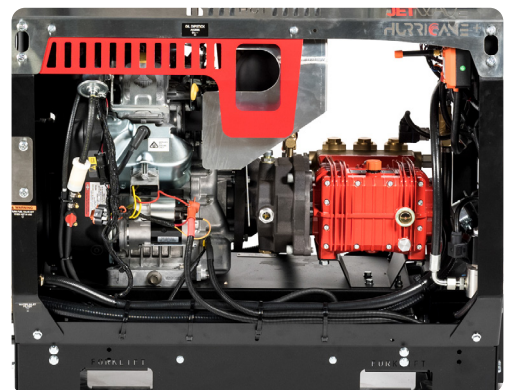

STANDOUT FEATURES

- Quick release tow coupling with 50mm ball.
- Heavy duty jockey wheel.
- Full Galvanised construction.
- On-board 200L water tank, with low level water cut out protection and high flow inlet float valve.
- Sunraysia style wheels and heavy duty tyres.
- Industrial A-Frame high & low pressure hose reels, 60m drain cleaning hose & 30m inlet feed hose fitted.

STANDARD EQUIPMENT



A-Frame Low Pressure Reel + 30m 3/4" Low Pressure Inlet Hose

A Frame High Pressure Reel + 60m 3/8" water jetting hose



200L On-board Water Cartage Tank & Float Valve w/Low Level Cut Out



1200mm Alloy lockable tool box



Hurricane Machine w/standard accessories

DIMENSIONS (MM)

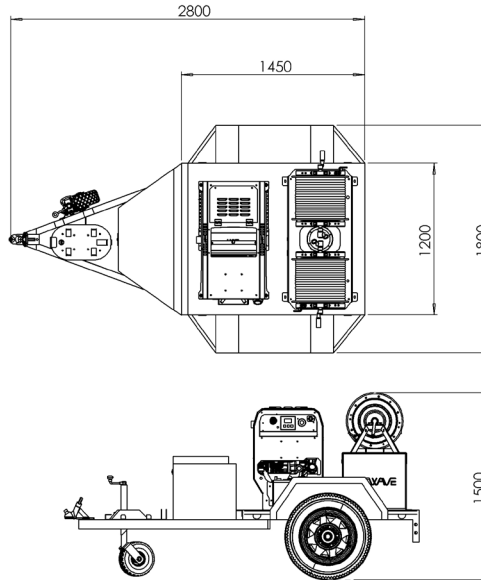

TRAILER FEATURES

HURRICANE⁺ LITE TRAILER

Product Codes	JH4400-33PBLITETRAILER JH5000-36PBLITETRAILER
Origin	Made in Australia
Materials / Wheels	Welded RHS algav subframe (paint finished) 2mm galvanised dimple sheet flooring
Suspension System / Spare Wheel	5 Leaf slipper / N
Tyres & Wheels	8 Ply tyres on white ranger rims
Axle & Hubs / Brakes	Heavy duty B45 square axle 6 Stud Hubs / No brakes
Tow Hitch / Jockey Wheel	50mm Ball coupling / AL-KO or equivalent swing up
Plug Type / Lights	7 Pin flat / Maintenance Free LED
Trailer Rating	750KG
Other Features	Soldered electrics / A-Frame draw bar / Front & rear in fills

WATERTANK FEATURES



Origin / Material	Made in Australia / Polyethylene
Tank Fill Lid / UV Stabilised	Y / Y
Tank Capacity	200L

HOSE REELS

Type	2 x Apache A-Frame
Capacity	Up to 100m of 3/8" High Pressure Hose

DIMENSIONS & WEIGHT



Total Dimensions	2800mm(L) x 1800mm(W) x 1500mm(H)
Total Weight (approx.)	550KG (dry) / 730KG (wet)

WARRANTY(S)



Trailer Warranty	1 Years
Water Tank Warranty	5 Years

OPTIONAL UPGRADES

SA Trailer Registration (3 Month) + Plate Fee	REGO
Apache A-Frame Hose Reel Guides	2100463

Copyright © 2023 Jetwave® Group Pty Ltd. All Rights Reserved.

The manufacturer reserves the right to modify design features and technical facts without notice, due to our principals of continuous improvement.

*Coverage against defects in material and workmanship (refer to Jetwave's and component partners T&Cs).

V3.0 07/23