

PMG™ G2FI 280 & 350



4060/5075
PSI

31/25*
L/PM

**V-TWIN PETROL
EFI IGX800**
ENGINE TYPE
POWERED BY
HONDA.

**GEARBOX
1450RPM
DRIVE**

**COLD
WATER
OUTPUT**

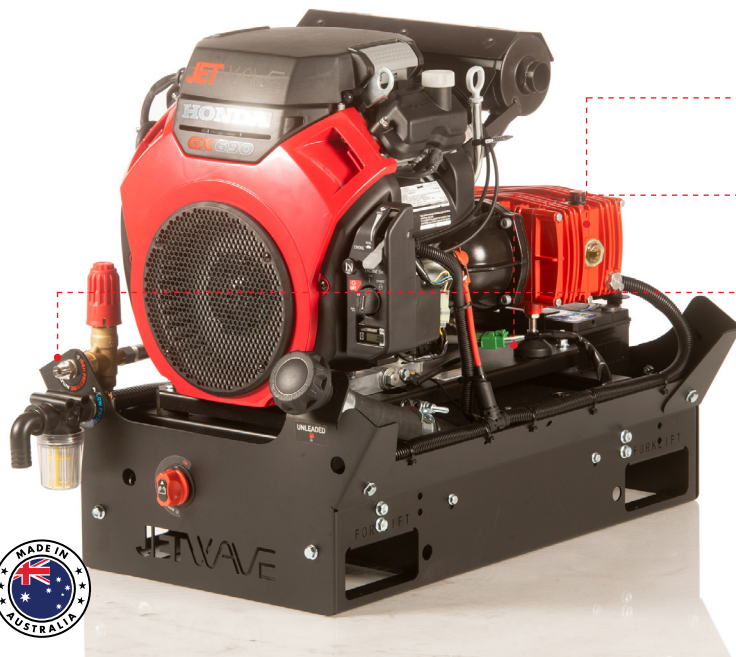

HERO INNOVATIONS

- JWPP™**
Jetwave Italian Premium Pump
- AVPS™**
Anti Vibration Protection System
- PMC™**
Panel/Bulk Head Mounted HP/LP Points
- AST™**
Auto Speed Technology
- TURN KEY SOLUTION**
Quality assured and ready to go

APPLICATIONS

- High Pressure Cleaning
- Drain Cleaning/Water Jetting
- Truck, Ute & Trailer Mounting
- External Water Tank & Bypass Ready

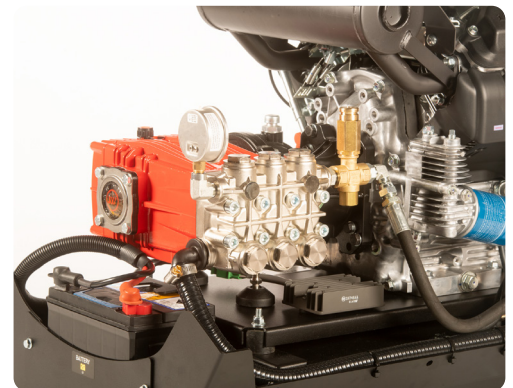
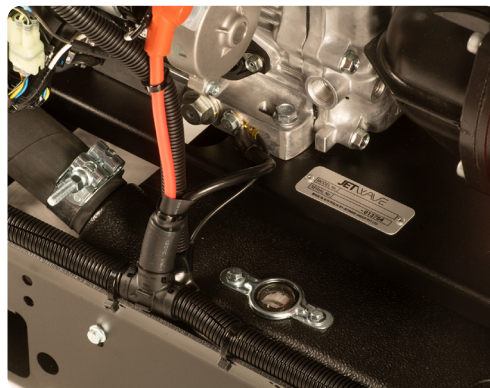







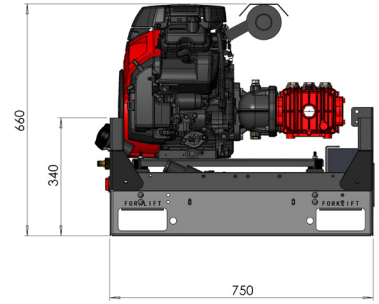
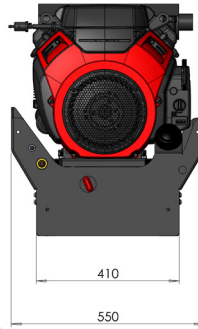
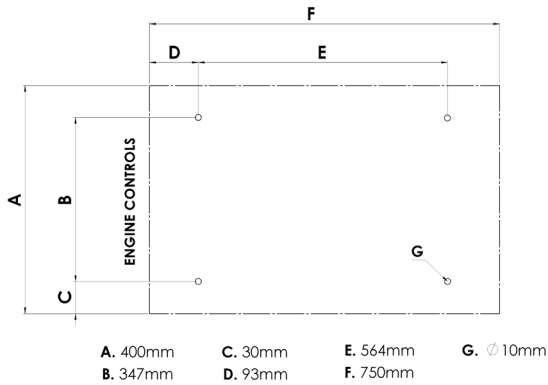

STANDOUT FEATURES

- JW® Enhanced Italian triplex plunger pump running at 1450RPM delivers more performance and longer life.
- Electric start Industrial V-Twin EFI Honda™ iGX800 Series Engine with auto speed technology (auto RPMS) & digital engine hour meter.
- Jetwave Safety System™ (JSS) safety valve to prevent over pressurisation.
- Seamless 25L on-board fuel tank under chassis mount, with level gauge.
- Battery isolator to prevent battery voltage loss, when not in use.
- Integrated forklift pockets & mounting points.

MOUNTING FOOTPRINT

DIMENSIONS (MM)



TECHNICAL DATA 	PMG™ G2FI 280-31	PMG™ G2FI 350-25	
Product Code	PM4000-31PEG2FI	PM5000-25PEG2FI	
Pressure / Flow Rate	4060 PSI (280 BAR) / 31 L/PM	5075 PSI (350 BAR) / 25' L/PM	
Max Water Inlet Temp	60C°		
Class (ASNZS: 4223)	B (8,680 Bar/Litres)	B (8,750 Bar/Litres)	
Usage Frequency	Professional: 4 Hours Daily		
Nozzle Size	O8	O55	
Frame Structure	CNC Modular galvanised steel chassis plus satin powder coat finish		
MOTOR FEATURES 			
Engine / Power	Honda™ iGX800 Electric Key Start (air cooled w/auto speed tech) 25HP / 800cc		
Fuel Type / Capacity / Protection	Unleaded / 25L (w/level gauge) / Low Oil Shutdown		
HYDRAULIC FEATURES 			
Pump / Head / Pistons	JW® Italian Triplex Plunger / Brass (Nickle Plated) / Ceramic		
Motor Pump Coupling / Pump RPM	Gearbox Drive / 1450RPM		
Unloader Valve	Independent (Panel Mounted)		
Safety Valve	Yes		
DIMENSIONS & WEIGHT 			
Machine Dimensions / Weight	750mm(L) x 550mm(W) x 660mm(H) / 130KG (approx.)		
WARRANTY(S) 			
Pump Warranty*	 2 Years		
Engine Warranty*	 3 Years		
OPTIONAL ACCESSORIES			
21" Hammerhead - Plastic	JWA-FSC21	Low Level Water Cut Out	JWA220
21" Hammerhead - Stainless Steel	JWA-FSC21-5		
Professional Nozzle Kit	JWA308		
Remote Mini Reel w/60m 1/4" Hose	PW134-RRCMPL/HOP4		

*Stated pump flow rate may vary in reality with on-board water tank vs direct feed.

The manufacturer reserves the right to modify design features and technical facts without notice, due to our principals of continuous improvement.

*Coverage against defects in material and workmanship (refer to Jetwave's and component partners T&Cs).

V2.3 04/22