



FUEL MANAGEMENT SYSTEMS



DISPENSERS



KITS



PUMPS



METERS



NOZZLES

FILTROLL



FEATURES

- DOUBLE-STAGE FILTRATION
- SPIRAL TUBE
- EASY TO HANDLE
- LARGE-DIAMETER WHEELS

The PIUSI FILTROLL is an innovative portable unit that provides a complete double filtering capacity of any kind of tank while absorbing water and impurities. The built-in sturdy trolley allows the operator to easily handle this device in any condition. It is equipped with suction pipe and integrated bottom valve.

PERFORMANCE

| | |
|--------------------------------|-------------------------|
| UP TO 56 L/MIN | AC/DC VOLTAGE |
| FLOW RATE | POWER |
| 30μ WATER ABSORPTION | 5μ IMPURITIES |
| FILTERING | FILTERING |



FILTROLL

PACKAGING

| CODE | WEIGHT | | PACKAGING | | |
|-----------|--------|------|-------------|----------------|---------|
| | KG | LBS | MM | INCH | PCS/BOX |
| FO0506000 | 35 | 77,2 | 790X590X590 | 31,1X23,2X23,2 | 1 |
| FO050606A | 40 | 88,2 | 790X590X590 | 31,1X23,2X23,2 | 1 |



FILTRATION



TANK MONITORING



HOSE REEL



ACCESSORIES



MERCHANDISE

PIUSI



AIR



ANTIFREEZE



AdBlue®



BIODIESEL



DIESEL



FOOD



GASOLINE



GREASE



KEROSENE



OIL



WATER



WINDSCREEN

CHART

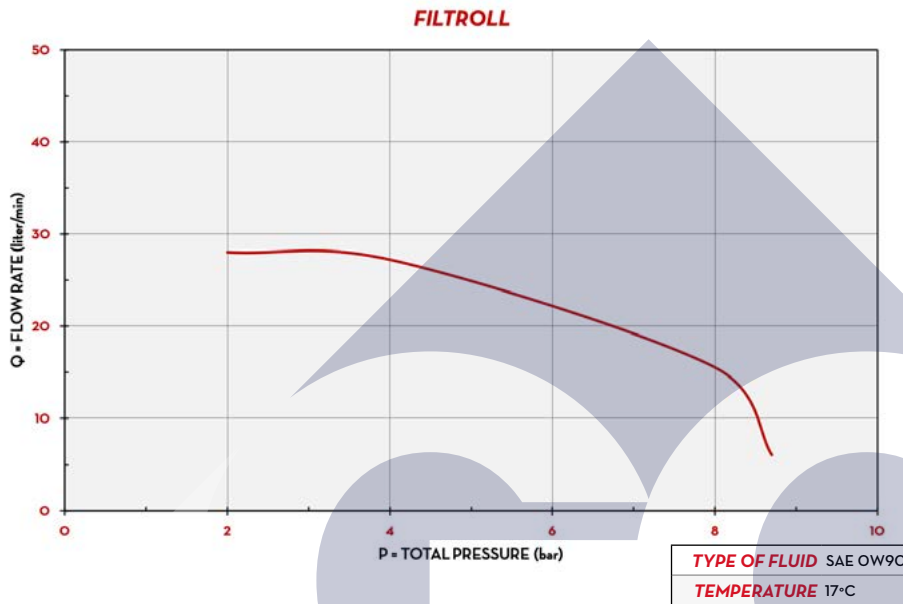

IN THE BOX

- FILTROLL UNIT
- SUCTION HOSE
- DELIVERY HOSE
- NOZZLE
- INSTRUCTION MANUAL

DETAILS



TWO-STEP FILTRATION



WATER/IMPURITIES FILTERS

DIMENSIONS

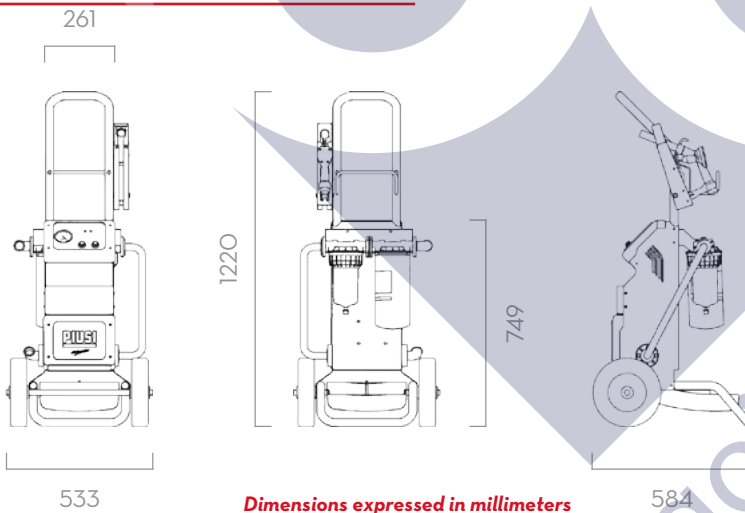

MATERIALS

- BODY: CAST IRON
- ROTOR: SINTHERED STEEL
- VANES: TECHNOPOLYMER
- SHAFT: STEEL
- FILTER: ABSORBENT FILTERING PAPER

TECHNICAL DATA

| CODE | DESCRIPTION | FLUIDS TYPE | FLOW RATE | | VOLTAGE | | | PUMP TYPE | HOSE LENGTH | |
|-----------|---------------------|-------------|-----------|------|------------------|------------|-----------|-----------|----------------|---------------|
| | | | L/MIN | GPM | AC V./HZ DC VOLT | POWER WATT | AMP. MAX. | | DELIVERY M/FT. | SUCTION M/FT. |
| FO0506000 | FILTROLL DIESEL | D | 56 | 14,8 | 230/50-60 | 350/600 | 3/6 | PANTH. 56 | 4 / 13,1 | 3 / 9,8 |
| FO050606A | FILTROLL 12V DIESEL | D | 56 | 14,8 | 12 | 300 | 35 | PANTH. DC | 4 / 13,1 | 4 / 13,1 |

FILTER CARTRIDGE

| CODE | DESCRIPTION | MICRO | EFFICIENCY |
|-----------|------------------------------|-------|------------|
| | | μ m | |
| FO061102A | WATER CAPTOR CART. 150 L/MIN | 30 | 200 |
| FO0611030 | CLEAR CAPTOR CARTRIDGE | 5 | 2 |

FILTER HEAD

| CODE | DESCRIPTION | | |
|-----------|------------------------------|---|---|
| F1693400A | FILTER HEAD 70/100LT W/MANOM | - | - |
| F15744000 | CLEAR CAPTOR FILTER HEAD | - | - |

AVAILABLE IN VERSION 230V/60HZ, 120V/60HZ

FILTROLL

FILTERING SYSTEM

169