



KITS



PUMPS



METERS



METERED NOZZLES



NOZZLES



WASTE OIL EQUIPMENTS

OIL KIT



FEATURES

- DOUBLE EFFECT PUMP
- HEAVY DUTY
- READY TO USE
- COMPACT DESIGN

The OIL KIT are oil dispenser units suitable to transfer medium/high viscosity lubricants. They can include P3.5:1 pneumatic pump, EASY K400 nozzle, Hose Reel, Drip Tray and Wall Kit.



PERFORMANCE

UP TO 21,5 L/MIN	3-8 BAR
FLOW RATE	OPERATING PRESSURE
± 0,5%	MID-HIGH
ACCURACY	VISCOSITY



OIL IBC KITS



OIL DRUM KIT 200 3.5 W/ METER - HR
FKO100020



OIL WALL DRUM KIT 200 3.5 W/ METER - HR
FKO100030



FILTRATION



FLUID MONITORING



TANK MONITORING



HOSE REELS



ACCESSORIES



MERCHANDISE



AIR



ANTIFREEZE



AdBlue®



BIODIESEL



DIESEL



FOOD



GASOLINE



GREASE



KEROSENE



OIL



WATER



WINDSCREEN

INDEX

OIL DRUM KIT*

KIT CODE	KIT DESCRIPTION		PUMP	NOZZLE	HOSE	HOSE REEL	ACCESSORIES
FK0100000	OIL DRUM KIT 200 3.5 W/O METER	DESCRIPTION	P3.5:1 940	EASY OIL	5MT M/F 1/2" 150 BAR	-	-
		CODE	FO021402A	FO0966140	F19974000	-	-
		PAGE	30	110	-	-	-
FK0100010	OIL DRUM KIT 200 3.5 W/ METER	DESCRIPTION	P3.5:1 940	EASY K400	5MT M/F 1/2" 150 BAR	-	-
		CODE	FO021402A	FO0984010	F19974000	-	-
		PAGE	30	92	-	-	-
FK0100020	OIL DRUM KIT 200 3.5 W/ METER - HR	DESCRIPTION	P3.5:1 940	EASY K400	2MT F/F 1/2" 150 BAR	OPEN 60B W/ 1/2" 15MT OIL	-
		CODE	FO021402A	FO0984010	F19973000	HA6015120B	-
		PAGE	30	92	-	172	-
FK0100030	OIL WALL DRUM KIT 200 3.5 W/ METER - HR	DESCRIPTION	P3.5:1 ST	EASY K400	2MT F/F 1/2" 150 BAR	OPEN 60B W/ 1/2" 15MT OIL	SUCTION PIPE&WALL BRACKET
		CODE	FO021400A	FO0984010	F19973000	HA6015120B	F1997200A
		PAGE	30	92	-	172	-
FK0100040	OIL DRUM KIT 200 5.5 W/ METER	DESCRIPTION	P5.5 940	EASY K400	5MT M/F 1/2" 150 BAR	-	-
		CODE	FO021403A	FO0984010	F19974000	-	-
		PAGE	32	92	-	-	-
FK0100050	OIL DRUM KIT 200 5.5 W/ METER - HR	DESCRIPTION	P5.5 940	EASY K400	2MT F/F 1/2" 150 BAR	OPEN 60B W/ 1/2" 15MT OIL	-
		CODE	FO021403A	FO0984010	F19973000	HA6015120B	-
		PAGE	32	92	-	172	-
FK0100060	OIL WALL DRUM KIT 200 5.5 W/ METER - HR	DESCRIPTION	P5.5 ST	EASY K400	2MT F/F 1/2" 150 BAR	OPEN 60B W/ 1/2" 15MT OIL	SUCTION PIPE&WALL BRACKET
		CODE	FO021401A	FO0984010	F19973000	HA6015120B	F1997200A
		PAGE	32	92	-	172	-

OIL IBC KIT*

KIT CODE	KIT DESCRIPTION		PUMP	NOZZLE	HOSE	HOSE REEL	ACCESSORIES			
FK0500000	OIL IBC KITW/METER	DESCRIPTION	P3.5:1 ST	EASY K400	TUBO 5M M/F 1/2" 150 BAR	-	KIT PIPE GUIDE + DRIP COLLECTOR/ IBC	PORTA TUBO PER LAMIERA IBC (2PZ)	KIT SUCTION PIPE WALL BRACKET PN. PUMP	KIT MOUNT PLATE FOR IBC
		CODE	FO021400A	FO0984010	F19974000	-	FO2200210	F22002400	F1997200A	F22002000
		PAGE	30	92	-	-	-	-	-	-
FK0500010	OIL IBC KIT W/METER - HR	DESCRIPTION	P3.5:1 ST	EASY K400	TUBO 2M FD 1/2" - F 1/2" 90° 150 BAR	REEL OPEN 60B W/1/2" 15MT OIL (S)	KIT PIPE GUIDE + DRIP COLLECTOR/ IBC	PORTA TUBO PER LAMIERA IBC (2PZ)	KIT SUCTION PIPE WALL BRACKET PN. PUMP	KIT MOUNT PLATE FOR IBC
		CODE	FO021400A	FO0984010	F22002200	HA6015120B	FO2200210	F22002400	F1997200A	F22002000
		PAGE	30	92	-	-	-	-	-	-
FK0500020	OIL IBC KIT W/O METER	DESCRIPTION	P3.5:1 ST	EASY OIL	TUBO 5M M/F 1/2" 150 BAR	-	KIT PIPE GUIDE + DRIP COLLECTOR/ IBC	PORTA TUBO PER LAMIERA IBC (2PZ)	KIT SUCTION PIPE WALL BRACKET PN. PUMP	KIT MOUNT PLATE FOR IBC
		CODE	FO021400A	FO0966140	F19974000	-	FO2200210	F22002400	F1997200A	F22002000
		PAGE	30	110	-	-	-	-	-	-

*THE COMPONENTS OF THE KIT ARRIVES SEPARATED IN THE PACKAGE. UPON REQUEST IT'S AVAILABLE IN DIFFERENT KITS

OIL KIT



KITS



PUMPS



METERS



METERED NOZZLES



NOZZLES



WASTE OIL EQUIPMENTS

P3.5:1



FEATURES

- DOUBLE EFFECT
- LOW OPERATIONAL SPEED
- DURABILITY
- MAINTENANCE FREE
- 20% MORE POWERFUL COMPARED TO THE MARKET STANDARD
- COMPOSITE MATERIAL BODY
- NO OXIDATION/PARTICLES PROOF
- METAL FREE DIFFUSER

The PIUSI P3.5:1 is an oil piston pump, suitable for transferring medium viscosity oil over short distances. It is manufactured using selected materials to ensure high performance and durability.

PERFORMANCE

UP TO 21,5 L/MIN	MID-HIGH
FLOW RATE	VISCOSITY
3-8 BAR	BELOW 77 DB
AIR PRESSURE	NOISE LEVEL*



PIUSI P3.5:1 ST



PIUSI P3.5:1 940

PACKAGING

CODE	WEIGHT		PACKAGING			
	KG	LBS	MM	INCH	PCS/PALLET	PCS/BOX
PIUSI 3.5 ST						
FO021400A	3,5	7,7	495X125X130	19,5X4,9X5,1	-	1
PIUSI 3.5 940						
FO021402A	5,5	12,1	125OX125X130	43,2X4,9X5,1	-	1



FILTRATION



FLUID MONITORING



TANK MONITORING



HOSE REELS



ACCESSORIES



MERCHANDISE



AIR



ANTIFREEZE



AdBlue®



BIODIESEL



DIESEL



FOOD



GASOLINE



GREASE



KEROSENE



OIL



WATER



WINDSCREEN

INDEX

CHART

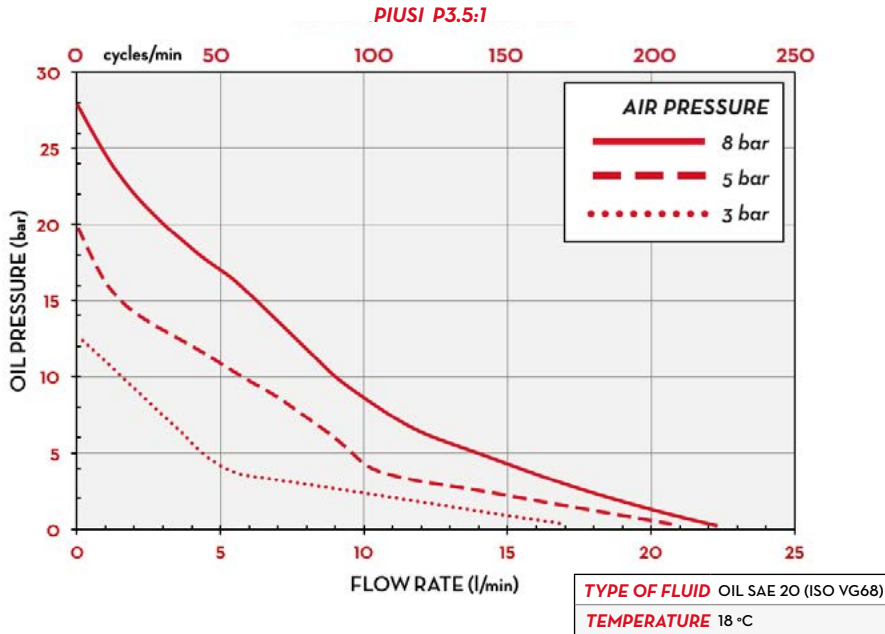

DIMENSIONS

PIUSI P3.5:1 ST

MEASURE "A"	445MM
MEASURE "B"	175MM
WEIGHT	4,5KG

PIUSI P3.5:1 940

MEASURE "A"	1210MM
MEASURE "B"	940MM
WEIGHT	5,5KG

PIUSI P3.5:1 ST

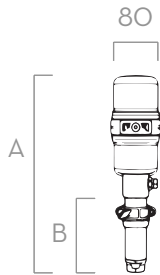

PIUSI P3.5:1 940

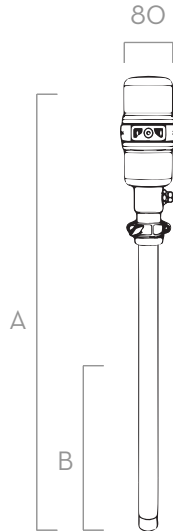

Dimensions expressed in millimeters

IN THE BOX

- PIUSI P3.5:1 ST / 940 PUMP
- BANG ADAPTER
- INSTRUCTION MANUAL

DETAILS



BANG ADAPTER



HEAVY DUTY BODY



INDUSTRIAL DESIGN



PRESSURE REGULATOR

MATERIALS

- AIR MOTOR: TECHNOPOLYMER
- BODY: DIE CAST STEEL
- SEAL: NBR

TECHNICAL DATA

CODE	DESCRIPTION	FLUIDS TYPE	FLOW RATE		COMPRESSION RATIO	WORKING PRESSURE		AIR CONSUMPTION	SUCTION PIPE		INLET	OIL SIDE CONNECTION		POLYURETHANE SEALS	
			L/MIN	GPM		BAR	PSI		MM	LENGHT MM		BSP	SUCTION BSP		OUTLET BSP
PIUSI 3.5 ST															
FOO21400A	PIUSI P3.5:1 ST		21,5	5,7	3.5:1	3-8	43,5-116	200-250	50	175	F.1/4"	F.1"	M.1/2"	YES	
PIUSI 3.5 940															
FOO21402A	PIUSI P3.5:1 940		21,5	5,7	3.5:1	3-8	43,5-116	200-250	50	940	F.1/4"	F.1"	M.1/2"	YES	

*MEASURING MADE WITH PUMP ASSEMBLED OVER DRUM TAKEN FROM 1 METER DISTANCE WITHOUT ANY ENVIROMENTAL NOISES.

P3.5:1



KITS



PUMPS



METERS



METERED NOZZLES



NOZZLES



WASTE OIL EQUIPMENTS

P5.5:1

FEATURES

- DOUBLE EFFECT
- LOW OPERATIONAL SPEED
- DURABILITY
- MAINTENANCE FREE
- 12% MORE POWERFUL COMPARED TO THE MARKET STANDARD
- COMPOSITE MATERIAL BODY
- NO OXIDATION/PARTICLES PROOF
- METAL FREE DIFFUSER

The PIUSI P5.5:1 is an oil piston pump, suitable for transferring medium viscosity oil over medium distances. It is manufactured using selected materials to ensure high performance and durability.



PERFORMANCE

UP TO 15,5 L/MIN	BELOW 77 DB
FLOW RATE	NOISE LEVEL*
3-8 BAR	MID-HIGH
AIR PRESSURE	VISCOSITY



PIUSI P5.5:1 ST



PIUSI P5.5:1 940

PACKAGING

CODE	WEIGHT		PACKAGING			
	KG	LBS	MM	INCH	PCS/PALLET	PCS/BOX
PIUSI 5.5 ST						
FO021401A	5,5	7,7	495X125X130	19,5X4,9X5,1	-	1
PIUSI 5.5 940						
FO021403A	5,5	12,1	125OX125X130	43,2X4,9X5,1	-	1



FILTRATION



FLUID MONITORING



TANK MONITORING



HOSE REELS



ACCESSORIES



MERCHANDISE



AIR



ANTIFREEZE



AdBlue®



BIODIESEL



DIESEL



FOOD



GASOLINE



GREASE



KEROSENE



OIL



WATER



WINDSCREEN

INDEX

CHART

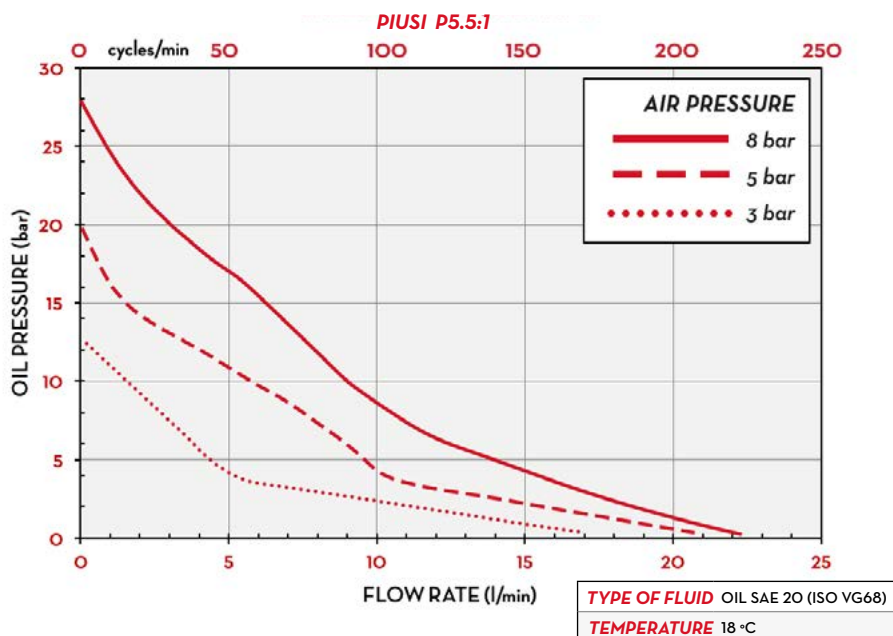

DIMENSIONS

PIUSI P5.5:1 ST

MEASURE "A"	445MM
MEASURE "B"	175MM
WEIGHT	3,5KG

PIUSI P5.5:1 940

MEASURE "A"	1210MM
MEASURE "B"	940MM
WEIGHT	5,5KG

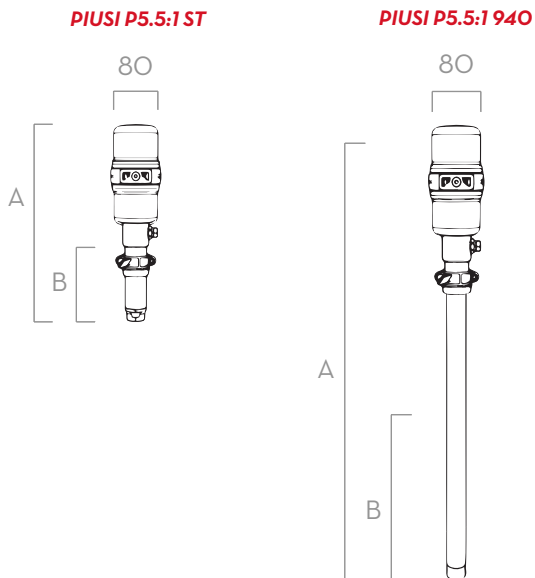

Dimensions expressed in millimeters

IN THE BOX

- PIUSI P5.5:1 ST / 940 PUMP
- BANG ADAPTER
- INSTRUCTION MANUAL

DETAILS



BANG ADAPTER



HEAVY DUTY BODY

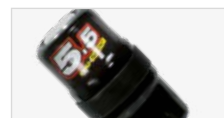

INDUSTRIAL DESIGN



PRESSURE REGULATOR

MATERIALS

- AIR MOTOR: TECHNOPYLIMER
- BODY: DIE CAST STEEL
- SEAL: NBR

TECHNICAL DATA

CODE	DESCRIPTION	FLUIDS TYPE	FLOW RATE		COMPRESSION RATIO	WORKING PRESSURE		AIR CONSUMPTION	SUCTION PIPE		INLET	OIL SIDE CONNECTION		POLYURETHANE SEALS	
			L/MIN	GPM		BAR	PSI		MM	LENGHT MM		BSP	SUCTION BSP		OUTLET BSP
PIUSI 5.5 ST															
FOO21401A	PIUSI P5.5 ST		15,5	4,1	5.5:1	3-8	43,5-116	200-250	42	175	F.1/4"	F.1"	M.1/2"	YES	
PIUSI 5.5 940															
FOO21403A	PIUSI P5.5 940		15,5	4,1	5.5:1	3-8	43,5-116	200-250	42	940	F.1/4"	F.1"	M.1/2"	YES	

*MEASURING MADE WITH PUMP ASSEMBLED OVER DRUM TAKEN FROM 1 METER DISTANCE WITHOUT ANY ENVIROMENTAL NOISES.

P5.5:1



KITS



PUMPS



METERS



METERED NOZZLES



NOZZLES



WASTE OIL EQUIPMENTS

EASY K400



FEATURES

- READY TO USE
- EASY TO CALIBRATE
- DOUBLE TOTALIZER
- ELECTRONIC RESET FUNCTION
- HIGH ACCURACY
- ERGONOMIC GRAB
- LOW BATTERY CONSUMPTION
- IP65 PROTECTION
- RUBBER PROTECTION
- ADJUSTABLE UMA CAMSHAFT
- SWIVEL

The PIUSI EASY K400 is the perfect synthesis for all the needs of transferring and measuring oils. It is composed by the ergonomic EASY OIL nozzle and the K400 meter.

PERFORMANCE

UP TO 30 L/MIN	70 BAR
FLOW RATE	OPERATING PRESSURE
± 0,5%	UP TO 2000 CST
ACCURACY	VISCOSITY



EASY K400 WITH FLEXIBLE SPOUT



with rigid spout

without spout



PACKAGING

CODE	WEIGHT		PACKAGING			N. BOXES/ EUROPALLET	
	KG	LBS	MM	PCS/PALLET	PCS/BOX		
FO0984040	1,2	2,6	300X160X110		1	180	180
FO0984010	1,5	3,3	300X160X110		1	180	180
FO0984000	1,5	3,3	300X160X110		1	180	180
FO0984070	1,5	3,3	300X160X110		1	180	180
FO0984060	1,5	3,3	300X160X110		1	180	180



FILTRATION



FLUID MONITORING



TANK MONITORING



HOSE REELS



ACCESSORIES



MERCHANDISE



AIR



ANTIFREEZE



AdBlue®



BIODIESEL



DIESEL



FOOD



GASOLINE



GREASE



KEROSENE



OIL



WATER



WINDSCREEN

INDEX

CHART

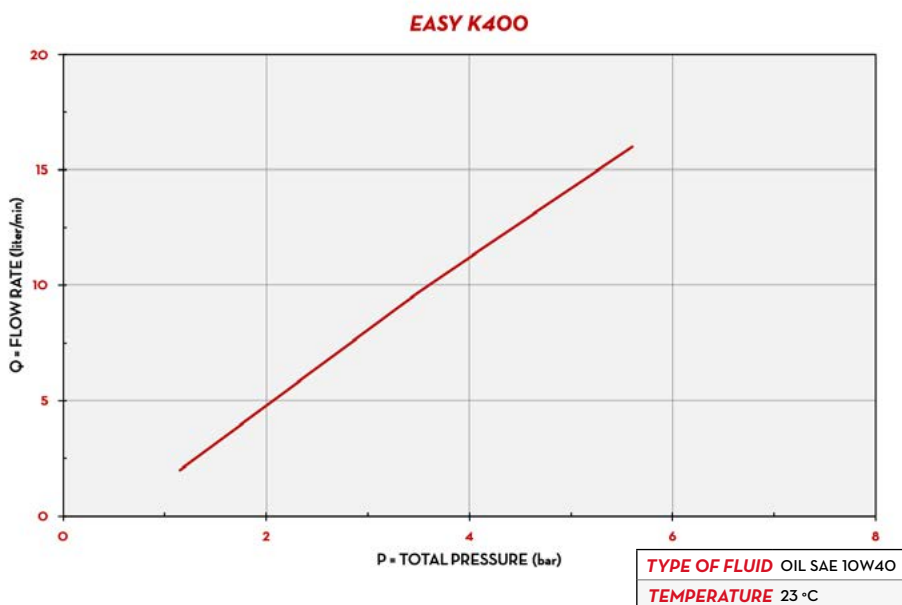

DIMENSIONS

EASY K400 METER SIDE/FRONT

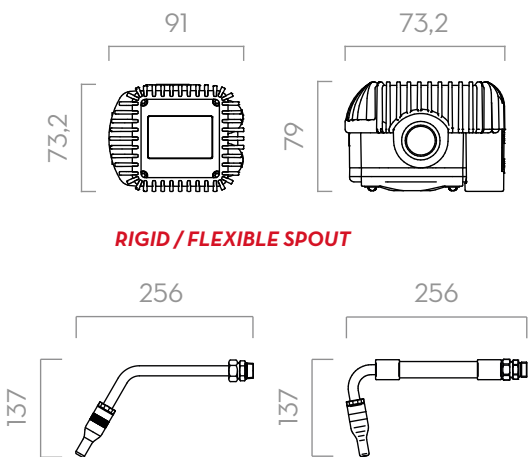

EASY K400 NOZZLE METER SIDE

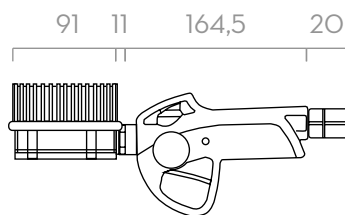

Dimensions expressed in millimeters

IN THE BOX

- EASY OIL NOZZLE
- K400 METER
- INSTRUCTION MANUAL

DETAILS



RESET/CALIBRATE BUTTON



MULTIFUNCTIONAL DISPLAY



METER WITH OVAL GEARS



2 AAA BATTERIES INCLUDED

MATERIALS

- NOZZLE BODY: ALLUMINIUM
- VALVE: NBR, NICKEL PLATED STEEL, BRASS
- METER BODY: ALLUMINIUM
- GEARS: TECHNOPOLYMER

TECHNICAL DATA

CODE	DESCRIPTION	FLUIDS TYPE	SPOUT TYPE	AUTOMATIC NO DRIP VALUE	FLOW RATE		WORKING PRESSURE		BATTERIES 1,5 V SIZE AAA NO.	INLET	OUTLET
					L/MIN	GPM	BAR	PSI			
FO0984040	EASY K400 .7" BSP W/O SPOUT	Oil	-	-	1-30	0,26 - 7,8	70	994	2	1/2" BSP	1/2" BSP
FO0984010	EASY K400 .7" BSP W/FLEX SPOUT HP	Oil	FLEXIBLE AP	YES	1-30	0,26 - 7,8	70	994	2	1/2" BSP	FLEX EXT.
FO0984000	EASY K400 .7" BSP W/RIGID SPOUT HP	Oil	RIGID AP	YES	1-30	0,26 - 7,8	70	994	2	1/2" BSP	RIGID EXT.
FO0984070	EASY K400 .7" BSP W/FLEX SPOUT LP	Oil	FLEXIBLE BP	YES	1-30	0,26 - 7,8	70	994	2	1/2" BSP	FLEX EXT.
FO0984060	EASY K400 .7" BSP W/RIGID SPOUT LP	Oil	RIGID BP	YES	1-30	0,26 - 7,8	70	994	2	1/2" BSP	RIGID EXT.

NPT VERSION AVAILABLE - QUART, PINT, GALLON VERSION AVAILABLE. APPROVABLE VERSION ON REQUEST

EASY K400

METERED NOZZLES