



## LSR100

**Lockable static reel  
complete with cable and  
bonding clip.**

**A safe and reliable static  
earthing reel.**

### Key Features

- Reliable continuity is ensured through the use of a carbon brush on a stainless steel shaft. Stainless steel components are used to ensure corrosion does not break continuity.
- Simple to use locking mechanism prevents the static reel from unwinding due to vibration.
- Comes supplied with 30m of yellow cable for increased visibility at night.
- Manual operation as spring-rewind types have caused accidents when inadvertently released.
- Can be supplied with an optional cable guide (SR200-3) and spacer (7158).
- Nominal reel resistance is 5 ohms
- Meets AS 2809:2 – Maximum end-to-end resistance of 10 ohms.
- Carbon brush runs in sealed section to eliminate dirt and corrosion.
- Shaft has grease reservoir for all-of-life lubrication.
  - ◇ Body - Aluminium
  - ◇ Cable – Comes fitted with 30m of Yellow PVC coated galvanised wire
  - ◇ Shaft - Stainless steel
  - ◇ Brush - Carbon
  - ◇ Static clip – Aviation spec brass clip
  - ◇ Cable Guide - Zinc plated steel
  - ◇ Weight - 2.0 kg

Static reels are used to bond two pieces of equipment to allow static charge to be safely equalised. Static reels are typically used when product is transferred from one tank to another e.g. when pumping between a tanker and storage tank or when fuelling aircraft.

The LSR100 has been developed to provide users with a safe and reliable static earthing reel that when locked won't inadvertently unwind while a vehicle is moving.

The new locking mechanism design is another step further in our constant drive to improve safety.



# LSR100 Lockable Static Reel

Static reels are used to bond two pieces of equipment to allow static charge to be safely equalised. Static reels are typically used when product is transferred from one tank to another e.g. when pumping between a tanker and storage tank or when fuelling aircraft.

The LSR100 has been developed to provide users with a safe and reliable static earthing reel that when locked won't inadvertently unwind while a vehicle is moving.

The new locking mechanism design is another step further in our constant drive to improve safety.

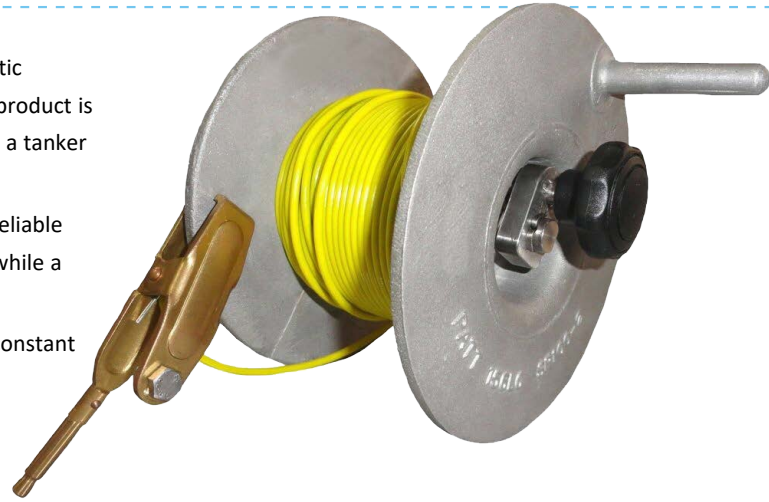

## Key Features

- Reliable continuity is ensured through the use of a carbon brush on a stainless steel shaft. Stainless steel components are used to ensure corrosion does not break continuity.
- Simple to use locking mechanism prevents the static reel from unwinding due to vibration.
- Comes supplied with 30m of yellow cable for increased visibility at night.
- Manual operation as spring-rewind types have caused accidents when inadvertently released.
- Can be supplied with an optional cable guide (SR200-3) and spacer (7158).

## Dismantle and Testing

- Test continuity regularly according to your company standards.
- Always remove the cable, brush spring and brush before withdrawing the shaft and fit the shaft first when reassembling.
- For installation instructions see LSR100 Installation Guide overleaf.

## Associated Equipment

- SR200-3 and 7158 – Optional cable guide/spacer for LSR100.
- SR200 – Larger diameter reel for faster winding, comes with cable guide fitted.

## Specifications

<b>Nominal reel resistance</b>	5 ohms
<b>Meets AS 2809:2</b>	Maximum end-to-end resistance of 10 ohms.
<b>Carbon brush</b>	Runs in sealed section to eliminate dirt and corrosion.
<b>Shaft</b>	Has grease reservoir for all-of-life lubrication.
<b>Materials</b>	<ul style="list-style-type: none"><li>• Body - Aluminium</li><li>• Cable – Comes fitted with 30m of Yellow PVC coated galvanised wire</li><li>• Shaft - Stainless steel</li><li>• Brush - Carbon</li><li>• Static clip – Aviation spec brass clip</li><li>• Cable Guide - Zinc plated steel</li></ul>
<b>Weight</b>	2.0 kg

# LSR100 - Locking Static Reel

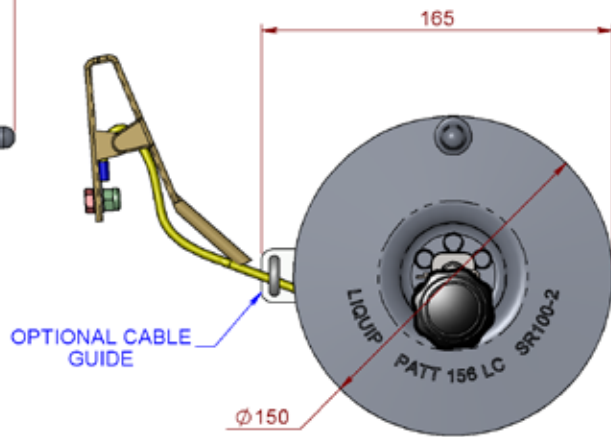
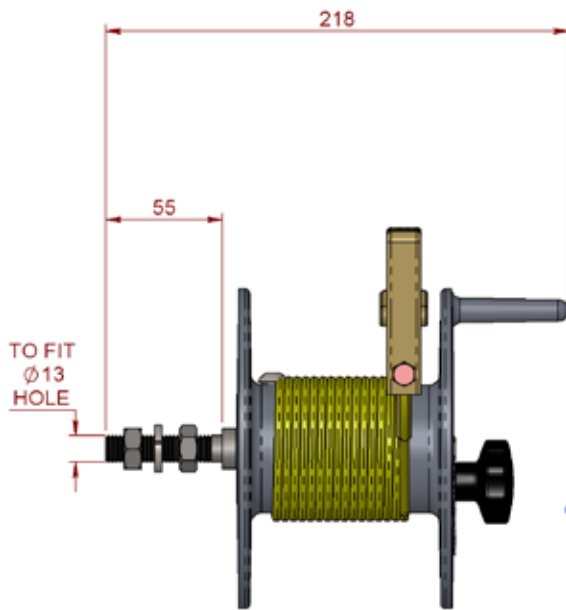
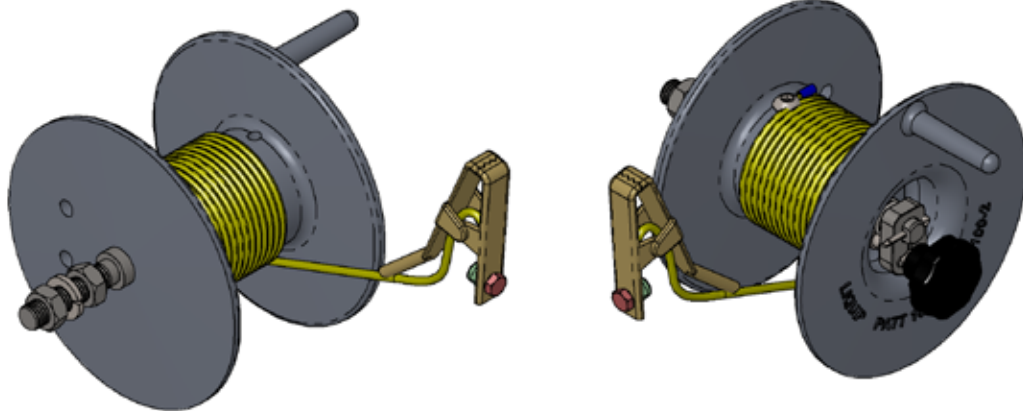

OPTIONAL CABLE  
GUIDE

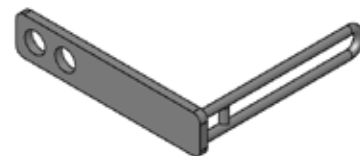

OPTIONAL CABLE GUIDE

**L110614**

Sheet 1 of 3  
Issue: B

# LSR100 - Locking Static Reel

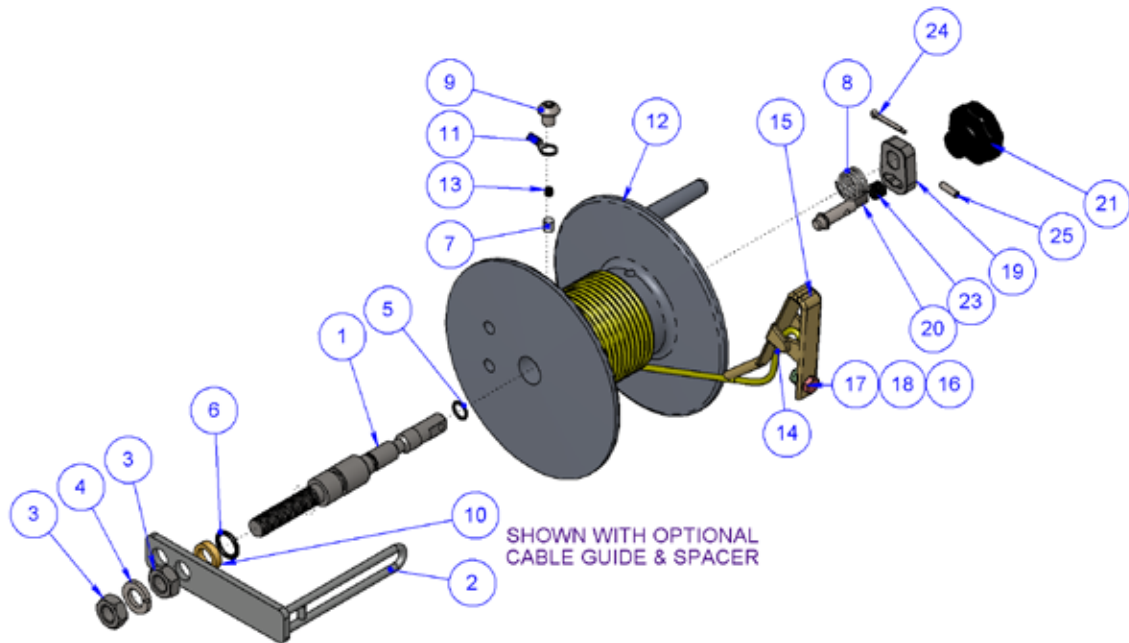

ITEM	PART No	DESCRIPTION	QTY.	MATERIAL
1	LSR100-3	SHAFT - MAIN	1	ST STEEL
2	SR200-3	CABLE GUIDE BRACKET	OPTIONAL	Z/P STEEL
3	0805	NUT - HALF	2	ST STEEL
4	0822	WASHER SPRING	1	ST STEEL
5	0159	O-RING	1	NITRILE
6	0223	O-RING	1	NITRILE
7	SR100-4	CARBON BRUSH	1	CARBON
8	0436	SPRING - SHAFT	1	ST STEEL
9	0040	CAPSCREW MET BUTT HD	1	STEEL
10	7158	SPACER - CABLE GUIDE	OPTIONAL	ST STEEL
11	1409	EYE TERMINAL	1	Z/P STEEL
12	SR100-2	BODY - STATIC REEL	1	ALUMINIUM
13	0437	SPRING COMPRESSION	1	SPRING STEEL
14	SR100-18	GROUNDING CABLE SR100	1	WIRE ROPE
15	KK100	CLIP STATIC	1	BRASS
16	1410	EYE TERMINAL	1	Z/P STEEL
17	4902	SETSCREW METRIC	1	ST STEEL
18	4399	NUT NYLOC	1	Z/P STEEL
19	LSR100-1	PIN GUIDE	1	ST STEEL
20	LSR100-2	LOCKING PIN	1	ST STEEL
21	58078	KNOB	1	PLASTIC
22	3380	LOCTITE	1	CYANOACRYLATE
23	0315	SPRING COMPRESSION	1	ST STEEL
24	0770	SPLIT PIN	1	ST STEEL
25	58080	SPRING (ROLL) PIN	1	Z/P STEEL

**L110614**

Sheet 2 of 3  
Issue: B

# LSR100 Installation Guide

Good electrical conductivity at the mounting bracket is essential to the performance of the static reel.

The mounting bracket itself must be chosen for its continuity with the vehicle chassis and both sides of the mounting bracket must provide a clean, smooth, bare metal surface of at least 15mm radius from the centre of the 13mm diameter hole. Ensure the inner nut is tightened securely on the shaft and fasten the assembly with the outer nut and spring washer on the other side of the mounting bracket.

For LSR100 fitted with the optional spacer and cable guide, fit onto the shaft first and tighten with the inner nut. The entire reel is then secured to the mounting bracket by the spring washer & outer nut on the other side of the bracket.

Further earthing continuity may be obtained by fitting a ring terminal and wire (not supplied) between the fixed nut and the mounting bracket and running it to a second earthing location on the chassis. Using a multimeter, confirm resistance from clamp to chassis is less than 10Ω.

