

G3™ Pro Automatic Lubrication Pump

332298L

EN

For dispensing of NLGI Grades #000 to #2 greases and oil with at least 40cSt. For Professional Use Only.

Not approved for use in explosive atmospheres or hazardous classified locations.

Part Nos., page 3

5100 psi (35.1 MPa, 351.6 bar) Pump Output Pressure

5000 psi (34.4 MPa, 344.7 bar) Fill Inlet Pressure



Important Safety Instructions

Read all warnings and instructions in this manual. Save all instructions.

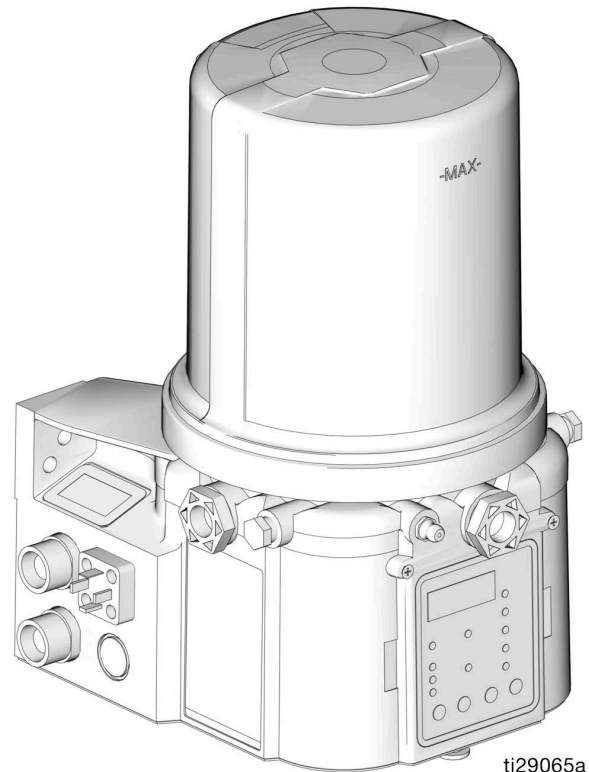

Conforms to ANSI/UL 73
Certified to CAN/CSA
C22.2 No 68



100-240VAC Pumps ONLY

PROVEN QUALITY. LEADING TECHNOLOGY.

Table of Contents

Part / Model Numbers	3
2 Liter ModelsG3	3
4 Liter Models	3
8 Liter Models	3
12 Liter Models	3
16 Liter Models	3
Understanding the Model Number	4
Warnings	5
Installation	8
Typical Installation	9
Typical Installation - With Remote	
Fill Manifold	10
Optional Installation - Without Remote	
Fill Manifold	11
Choosing an Installation Location	12
System Configuration and Wiring	13
Setup	17
Connecting to Auxiliary Fittings	17
Setting Pump Outlet Volume	18
Loading Grease	18
Auto-Fill Shut Off	21
Fill Oil Unit	23
Prime the pump	24
Quick Setup Guide	25
Pro Model Setup	26
Control Panel Overview (FIG. 24)	26
Instructions	27
Advanced Programming	31
Models with Firmware 5.01 and later	34
Models with Firmware 5.04 and later	35
Models with Firmware 5.06 and later	36
Run Mode	37
Time Control	37
Alarms: Firmware Versions 5.01 and Above	39
Fault / Warning Scenarios	39
Fault/Warning Scenarios for Firmware	
Versions 5.06 and Later	41
Troubleshooting	42
Maintenance	43
Parts - 2 Liter Models	44
Parts - 4 Liter and Larger Models	45
Parts	46
Mount Pattern	49
Technical Specifications	50
California Proposition 65	51
Graco Standard Warranty	52

Part / Model Numbers

The Part Number is a six-digit unique number that is only used to order the G3 Pump. Directly related to this six digit Part Number is the configured Graco Model Number. This configured number identifies the distinct features of a specific G3 Pump. To help you understand each component that makes up the Model Number see Understanding Your Model Number, page 4. The tables below shows the relationship between each Part Number and its related Model Number.

2 Liter ModelsG3

Part Numbers	Model Number	
96G011	G3-G-24PR-2L0L00-R0C00000	
96G012	G3-G-24PR-2LFL00-R0C00000	
96G013	G3-G-ACPR-2L0L00-0D000000	X
96G014	G3-G-ACPR-2LFL00-0D000000	X
96G027	G3-G-12PR-2L0000-00C00000	
96G028	G3-G-24PR-2L0000-00C00000	
96G029	G3-G-ACPR-2L0000-0D000000	X
96G033	G3-G-12PR-2L0L05-00C00000	
96G034	G3-G-24PR-2L0L05-00C00000	
96G070	G3-A-24PR-2L0L00-R0C00000	
96G079	G3-A-ACPR-2L0L00-0D000000	X
96G255	G3-G-12PR-2L0L07-00C00000	
96G285	G3-G-24PR-2L0007-0D000000	

8 Liter Models

Part Numbers	Model Number	
96G069	G3-G-24PR-8L0L00-R0C00000	
96G072	G3-A-24PR-8L0L00-R0C00000	
96G076	G3-G-ACPR-8L0L00-0D000000	X
96G081	G3-A-ACPR-8L0L00-0D000000	X
96G136	G3-G-12PR-8L0000-00C00000	
96G138	G3-G-24PR-8L0000-00C00000	
96G140	G3-G-ACPR-8L0000-0D000000	X
96G148	G3-G-12PR-8L0L05-00C00000	
96G150	G3-G-24PR-8L0L05-00C00000	
96G208	G3-G-ACPR-8LAL00-0D000000	X
96G214	G3-G-24PR-8LAL05-00C00000	
96G257	G3-G-24PR-8L0L07-00C00000	
96G268	G3-G-24PR-8LLL05-00C00000	
96G270	G3-G-24PR-8LFL07-00C00000	

4 Liter Models

Part Numbers	Model Number	
96G068	G3-G-24PR-4L0L00-R0C00000	
96G071	G3-A-24PR-4L0L00-R0C00000	
96G073	G3-G-24PR-4LFL00-R0C00000	
96G075	G3-G-ACPR-4L0L00-0D000000	X
96G080	G3-A-ACPR-4L0L00-0D000000	X
96G082	G3-G-ACPR-4LFL00-0D000000	X
96G135	G3-G-12PR-4L0000-00C00000	
96G137	G3-G-24PR-4L0000-00C00000	
96G139	G3-G-ACPR-4L0000-0D000000	X
96G147	G3-G-12PR-4L0L05-00C00000	
96G149	G3-G-24PR-4L0L05-00C00000	
96G211	G3-G-24PR-4LAL05-00C00000	
96G256	G3-G-24PR-4L0L07-00C00000	

12 Liter Models





Part Numbers	Model Number	
96G077	G3-G-ACPR-120L00-0D000000	X
96G163	G3-G-24PR-120L05-00C00000	
96G247	G3-G-24PR-120L00-R0C00000	

16 Liter Models

Part Numbers	Model Number	
96G078	G3-G-ACPR-160L00-0D000000	X
96G167	G3-G-24PR-160L05-00C00000	

Warnings

The following warnings are for the setup, use, grounding, maintenance, and repair of this equipment. The exclamation point symbol alerts you to a general warning and the hazard symbols refer to procedure-specific risks. When these symbols appear in the body of this manual or on warning labels, refer back to these Warnings. Product-specific hazard symbols and warnings not covered in this section may appear throughout the body of this manual where applicable.

 WARNING	
 	<p>ELECTRIC SHOCK HAZARD</p> <p>This equipment must be grounded. Improper grounding, setup, or usage of the system can cause electric shock.</p> <ul style="list-style-type: none"> • Turn off and disconnect power cord before servicing equipment. • Connect only to grounded electrical outlets. • Use only 3-wire extension cords. • Ensure ground prongs are intact on power and extension cords. • All electrical wiring must be done by a qualified electrician and comply with all local codes and regulations.
 	<p>EQUIPMENT MISUSE HAZARD</p> <p>Misuse can cause death or serious injury.</p> <ul style="list-style-type: none"> • Do not operate the unit when fatigued or under the influence of drugs or alcohol. • Do not exceed the maximum working pressure or temperature rating of the lowest rated system component. See Technical Data in all equipment manuals. • Use fluids and solvents that are compatible with equipment wetted parts. See Technical Specifications in all equipment manuals. Read fluid and solvent manufacturer's warnings. For complete information about your material, request MSDS from distributor or retailer. • Turn off all equipment and follow the Pressure Relief Procedure when equipment is not in use. • Check equipment daily. Repair or replace worn or damaged parts immediately with genuine manufacturer's replacement parts only. • Do not alter or modify equipment. Alterations or modifications may void agency approvals and create safety hazards. • Make sure all equipment is rated and approved for the environment in which you are using it. • Use equipment only for its intended purpose. Call your distributor for information. • Route hoses and cables away from traffic areas, sharp edges, moving parts, and hot surfaces. • Do not kink or over bend hoses or use hoses to pull equipment. • Keep children and animals away from work area. • Comply with all applicable safety regulations.

⚠ WARNING

	<p>SKIN INJECTION HAZARD</p> <p>High-pressure fluid from dispensing device, hose leaks, or ruptured components will pierce skin. This may look like just a cut, but it is a serious injury that can result in amputation. Get immediate surgical treatment.</p> <ul style="list-style-type: none"> • Do not point dispensing device at anyone or at any part of the body. • Do not put your hand over the fluid outlet. • Do not stop or deflect leaks with your hand, body, glove, or rag. • Follow the Pressure Relief Procedure when you stop dispensing and before cleaning, checking, or servicing equipment. • Tighten all fluid connections before operating the equipment. • Check hoses and couplings daily. Replace worn or damaged parts immediately.
	<p>PRESSURIZED EQUIPMENT HAZARD</p> <p>Over-pressurization can result in equipment rupture and serious injury.</p> <ul style="list-style-type: none"> • A pressure relief valve is required at each pump outlet. • Follow the Pressure Relief Procedure in this manual before servicing.
	<p>PLASTIC PARTS CLEANING SOLVENT HAZARD</p> <p>Many cleaning solvents can degrade plastic parts and cause them to fail, which could cause serious injury or property damage.</p> <ul style="list-style-type: none"> • Use only compatible solvents to clean plastic structural or pressure-containing parts. • See Technical Specifications in all equipment manuals for materials of construction. Consult the solvent manufacturer for information and recommendations about compatibility.

WARNING



MOVING PARTS HAZARD

Moving parts can pinch, cut or amputate fingers and other body parts.

- Keep clear of moving parts.
- Do not operate equipment with protective guards or covers removed.
- Equipment can start without warning. Before checking, moving, or servicing equipment, follow the **Pressure Relief Procedure** and disconnect all power sources.



PERSONAL PROTECTIVE EQUIPMENT

Wear appropriate protective equipment when in the work area to help prevent serious injury, including eye injury, hearing loss, inhalation of toxic fumes, and burns. Protective equipment includes but is not limited to:

- Protective eyewear, and hearing protection.
- Respirators, protective clothing, and gloves as recommended by the fluid and solvent manufacturer.

Installation

Component Identification

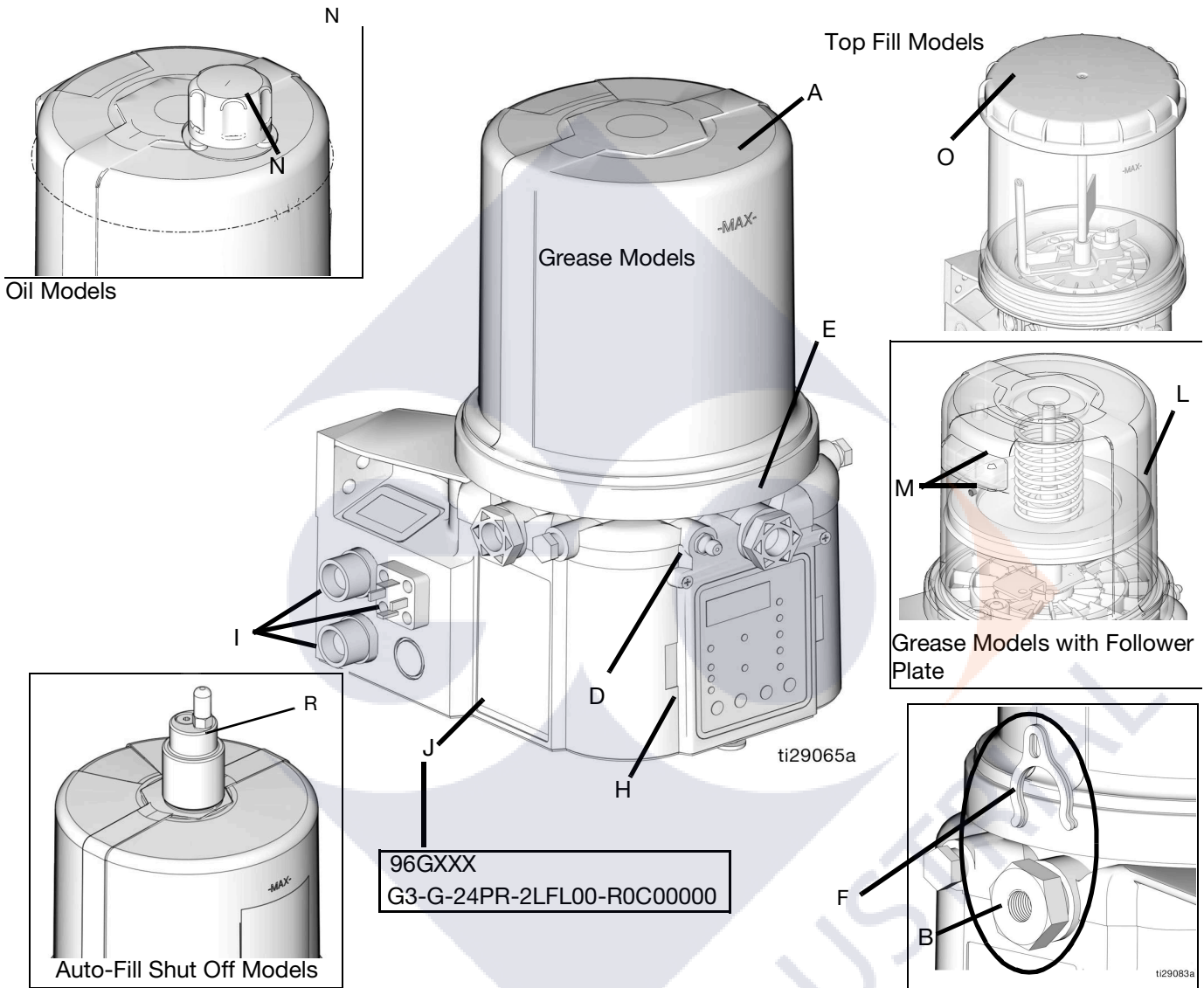

FIG. 2:

Key:

- | | |
|---|--|
| <ul style="list-style-type: none"> A Reservoir B Pump Element (1 included. Can accommodate 3 total) C Pressure Relief Valve (Not included / required for each outlet - Available from Graco. See Parts, page 48.) D Zerk Inlet Fill Fitting (1 included / grease models only) E Pump Outlet Plug (2 included) F Volume Control Spacers (2 included. More spacers = less output volume per stroke) (also see FIG. 11, page 18) G Fuse (DC models only - Not included, not shown. Available from Graco. See Parts, page 47.) H Control Panel I Power / Sensor Panel (both sides; only one side shown) J Part Number / Model Number example only shown, (see pages 4, Understanding the Model Number, for details) K Power Cord (Not shown) | <ul style="list-style-type: none"> L Follower Plate (grease models only / not available on all grease models) M Vent Hole for Follower Plate (grease models only / not available on all grease models) N Fill cap (oil models only) O Top Fill Lid R Auto-Fill Shut Off |
|---|--|

Typical Installation

Series Progressive Divider Valve Installations

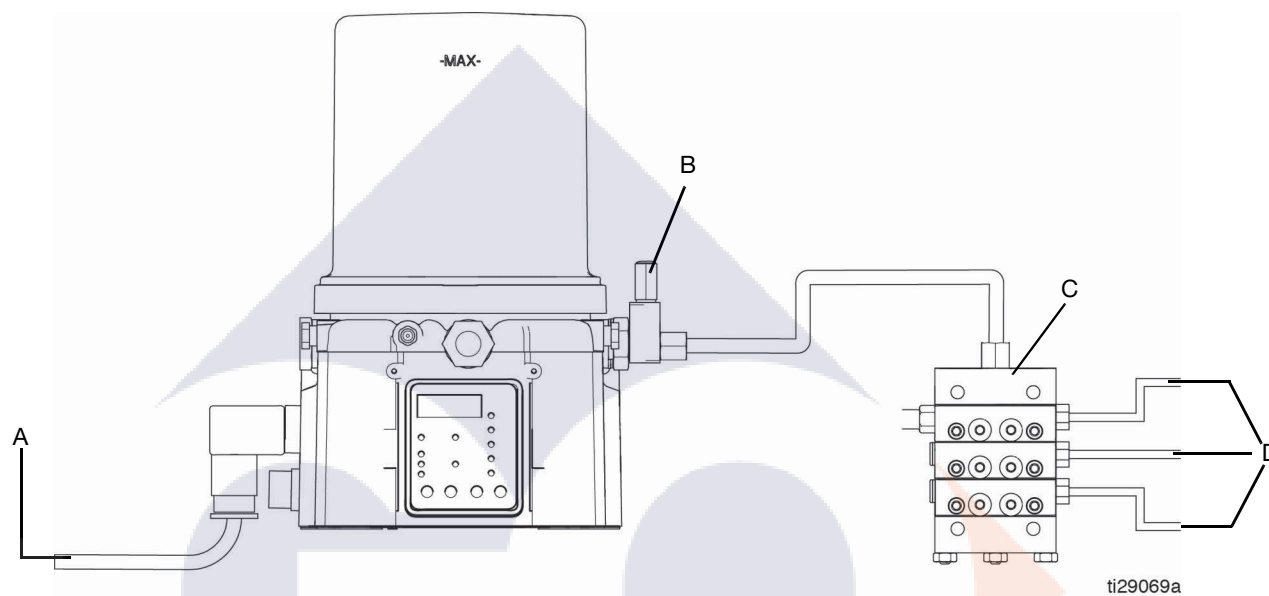

FIG. 3

- A Connected to fused power source
- B Pressure relief valve (Not included/required for each outlet - user supplied. See Parts, page 48)
- C Series progressive divider valves (Divider Installations)
- D To lube points

Typical Installation - With Remote Fill Manifold

The installation shown is only a guide for selecting and installing system components. Contact your Graco distributor for assistance in planning a system to suit your needs.

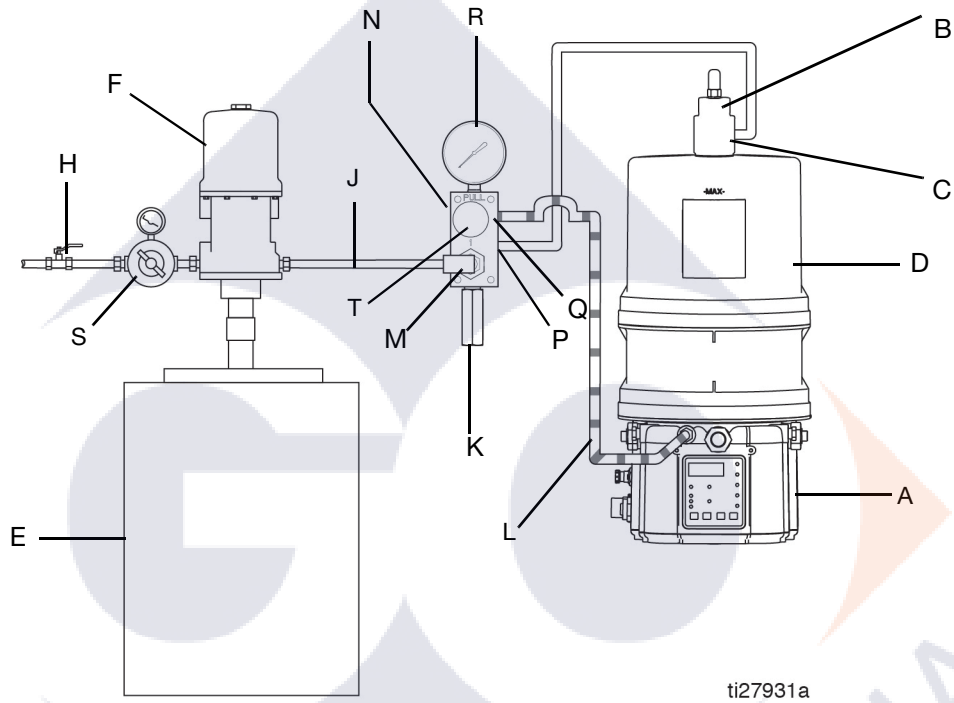

FIG. 4

Key:

- A G3 Pump
- B Auto-Fill Shut Off Valve
- C Auto-Fill Inlet
- D G3 Reservoir
- E Remote Fill Reservoir
- F Remote Fill Pump
- G Supply Hose (user supplied)
- H Air Supply to Refill Pump
- J Supply Hose (user supplied)
- K Pressure Relief Valve
- L Drain Hose
- M Fill Coupler/Inlet (quick disconnect)
- N Fill Manifold❖
- P Fill Manifold Outlet
- Q Fill Manifold Vent Port
- R Pressure Gauge
- S Pressure Regulator and Gauge
- T Pressure Relief Knob

❖ To relieve the stall pressure in the fill line a fill manifold (N) **must** be installed in the system.

Optional Installation - Without Remote Fill Manifold

The installation shown is only a guide for selecting and installing system components. Contact your Graco distributor for assistance in planning a system to suit your needs.

NOTE: The remote filling station pump stalls (dead-heads) when the reservoir is full. If the pump does not stall (dead-head) there is a leak in the system.

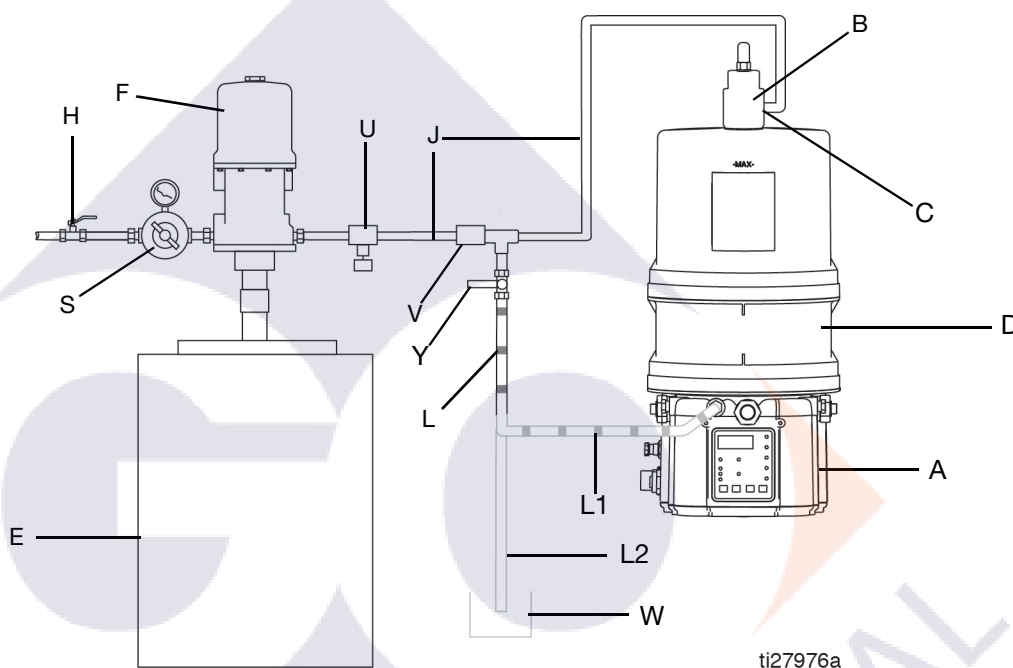

FIG. 5

Key:

- A G3 Pump
- B Auto-Fill Shut Off Valve
- C Auto-Fill Inlet
- D G3 Reservoir
- E Remote Fill Reservoir
- F Remote Fill Pump
- H Relief Valve
- J Supply Hose (user supplied)
- L Drain Tube
 - L1 Option - To reservoir
 - L2 Option - To overflow container

- S Pressure Regulator and Gauge
- U Pressure Relief Valve
- V Quick Disconnect
- W Overflow Container
- Y Supply Hose Pressure Relief Valve❖

❖ To relieve the stall pressure in the fill line a ball valve (Y) **must** be installed in the system.

Choosing an Installation Location



AUTOMATIC SYSTEM ACTIVATION HAZARD

If the system is equipped with has an automatic timer (user supplied) that activates the pump lubrication system when power is connected or when exiting the programming function, unexpected activation of the system could result in serious injury, including skin injection and amputation.

Before you install or remove the lubrication pump from the system, disconnect and isolate all power supplies and relieve all pressure.

- Select a location that will adequately support the weight of the G3 Pump and lubricant, as well as all plumbing and electrical connections.
- Refer to the mounting hole layouts provided in the Mounting Pattern section of this manual, page 49. No other installation configuration should be used.
- Use designated mounting holes and provided configurations only.
- Always mount the G3 oil models upright.

- Mount top fill G3 pump so that there is a minimum clearance of four inches (4.0 in.) (10.2 cm) above the reservoir to allow for lid removal and filling.
- If the G3 grease model is going to be operated in a tilted or inverted position for any period of time, you must use a model that includes a follower plate, otherwise the G3 must be mounted upright. Refer to your model number to confirm if a follower plate was installed on your pump. See page 4, Understanding the Model Number to identify this character in your model number.
- Use the three fasteners (included) to secure the G3 to the mounting surface.
- Some installations may require an additional reservoir support bracket. See table below for bracket information.
- In high vibration environments, additional isolation at mounting point is necessary. See table below.
- AC pumps are not recommended when high vibration or shock is present.

Part No	Description
571159	Reservoir bracket and strap
125910	L-Bracket for pump
127665	USP to G-Series mounting bracket
132187	Isolator mounting kit

System Configuration and Wiring

Grounding

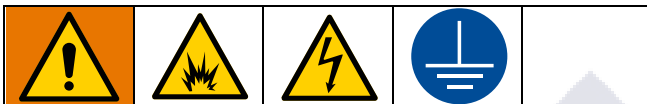

The equipment must be grounded to reduce the risk of static sparking and electric shock. Electric or static sparking can cause fumes to ignite or explode. Improper grounding can cause electric shock. Grounding provides an escape wire for the electric current.

Improper installation of the grounding conductor may result in a risk of electric shock. This product must be installed by a qualified electrician in compliance with all state and local codes and regulations.

If the product is permanently connected:

- It must be installed by a qualified electrician or serviceman.
- It must be connected to a grounded, permanent wiring system.

If an attachment plug is required in the end use application:

- It must be rated for the product electrical specifications.
- It must be an approved, 3-wire grounding type attachment plug.
- It must be plugged into an outlet that is properly installed and grounded in accordance with all local codes and ordinances.
- When repair or replacement of the power cord or plug is required, do not connect the grounding wire to either flat blade terminal.

Fuses

NOTICE

Fuses (user supplied) are required on all DC models. To avoid equipment damage:

- Never operate G3 Pump DC models without a fuse installed.
- A fuse of the correct current must be installed in line with the power entry to the equipment.

Fuse Kits are available from Graco. The following Table identifies the correct fuse to use for your input voltage and the corresponding Graco Kit number.

Input Voltage	Fuse Value	Graco Kit No.
12 VDC	7.5 A	571039
24 VDC	4 A	571040

Recommendations for Using Pump in Harsh Environments

- Use pump with CPC style power cable.
- If using a DIN style power or alarm harness with a right angle mating connector, make sure the connector does not exit the unit in the UP direction.
- Use a corrosion preventative electrical grease on all contacts.

Remote Illumination Response



The following tables include graphical representations of the connector as it appears on the unit, a pin-out associated with the connector and a typical installation wiring diagram. An internal representative wiring diagram is included where it is deemed useful.

Wire colors provided on these pages only refer to the power cable provided by Graco with this product.

	Standard Remote Illumination (via 5 wire CPC power cable)	Tri-Color Remote Illumination (M12 Connector)
Unit in OFF Mode	Off	Off
Unit in ON Mode	On	Green
Warning Condition	Toggles On and Off once per second	Yellow
Fault Condition	Toggles On and Off once per second	Red

Wiring and Installation Diagrams

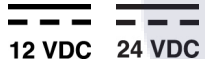
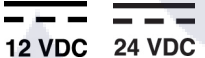
The following Table identifies the wiring and installation diagrams provided in this manual.

Diagram	Symbol	Page #
Power DIN AC	 AC	15
Power DIN DC	 12 VDC 24 VDC	15
Power CPC DC	 12 VDC 24 VDC	16
Illuminated Manual Run Input		Kits: 571030, 571031, 571032, 571033



Power DIN AC - 15 foot

AC

Pin and Related Wire Color (Fig. 6)

Pin	Pin Name	Color
1	Line	Black
2	Neutral	White
3	Not Used	Not Used
	Ground	Green

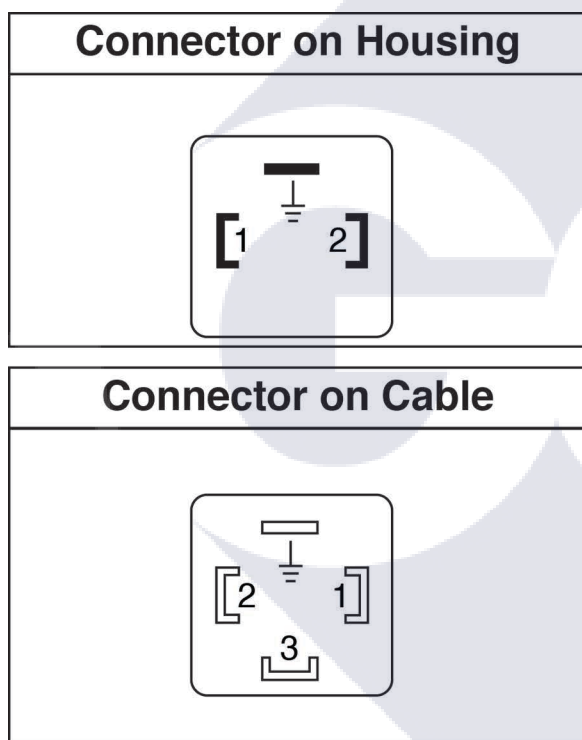

ti27630a

FIG. 6

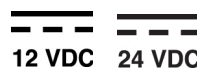

12 VDC 24 VDC Power DIN DC - 15 Foot

Pin and Related Wire Color (Fig. 7)

Pin	Pin Name	Color
1	-VDC	Black
2	+VDC	White
3	Not Used	Not Used
	Not Used	Green

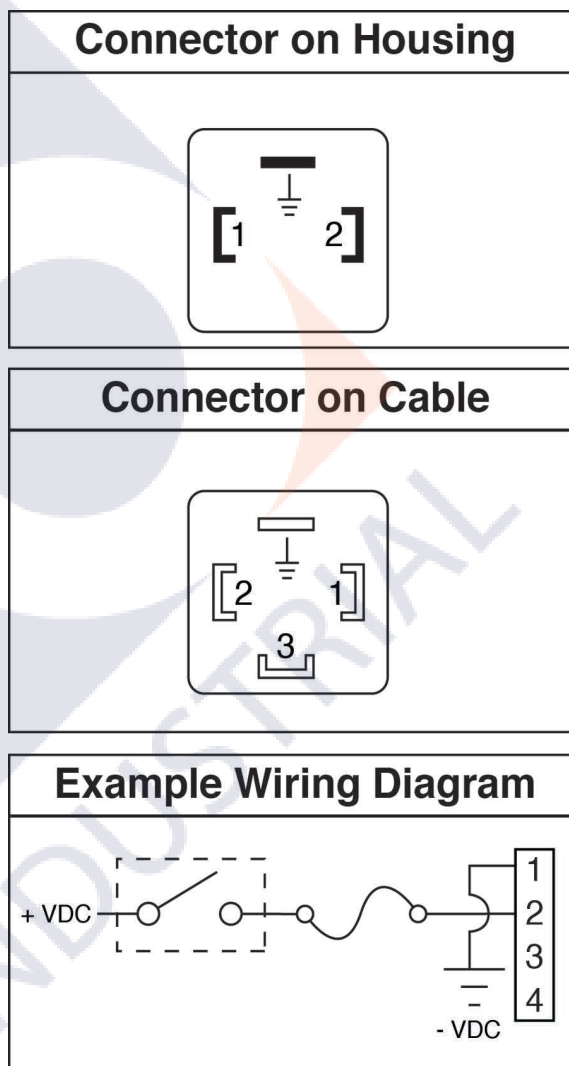

ti27631a

FIG. 7

12 VDC 24 VDC Power CPC DC - 2 Wire
 Part No.: 127783: 15 ft. (4.5 m)

Pin and Related Wire Color (Fig. 8)

Pin	Pin Name	Color
1	Not Used	Not Used
2	-VDC	Black
3	+VDC	White
4	Not Used	Not Used
5	Not Used	Not Used
6	Not Used	Not Used
7	Not Used	Green

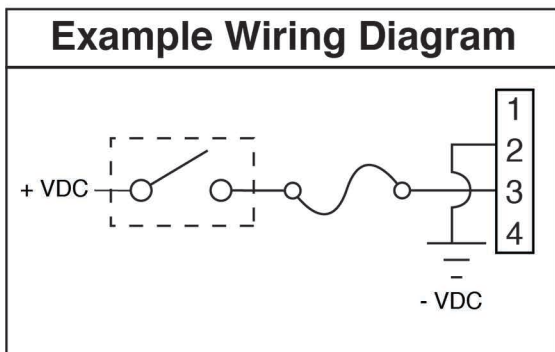
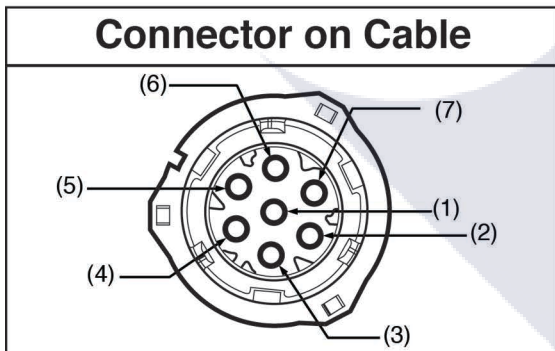
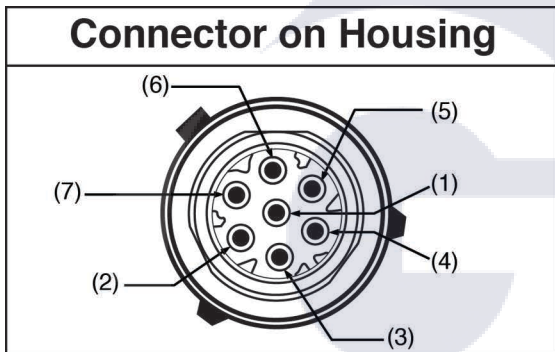

ti29557a

FIG. 8

12 VDC 24 VDC Power CPC DC - 5 Wire

Part No.: 127780: 15 ft (4.5 m)
Part No.: 127781: 20 ft (6.1 m)
Part No.: 127782: 30 ft (9.1 m)

An Illuminated Remote Run Button Kit: 571030, 571031 for starting a manual run cycle if used in conjunction with a 5-wire CPC cable, is available from Graco. Contact your local Graco distributor or Graco Customer Service for additional information about these kits.

Pin and Related Wire Color (Fig. 9)

Pin	Pin Name	Color
1	Not Used	Not Used
2	-VDC	Black
3	+VDC	Red
4	LIGHT	White
5	Manual Run Switch	Orange
6	Not Used	Not Used
7	Not Used	Green

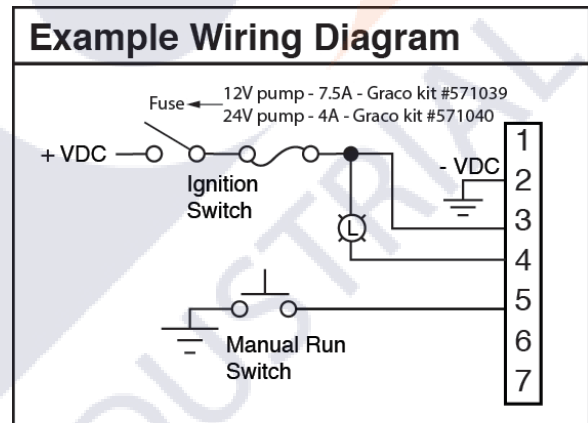

ti29070a

FIG. 9

Setup

Pressure Relief



Follow the Pressure Relief Procedure whenever you see this symbol.



This equipment stays pressurized until pressure is manually relieved. To help prevent serious injury from pressurized fluid, such as skin injection, splashing fluid and moving parts, follow the Pressure Relief Procedure when you stop dispensing and before cleaning, checking, or servicing the equipment.

Relieve pressure in system using two wrenches working in opposite directions on pump element and pump element fitting to **slowly loosen fitting only** until fitting is loose and no more lubricant or air is leaking from fitting.

NOTE: When loosening pump element fitting, do NOT loosen **pump element**. Loosening pump element will change the output volume.

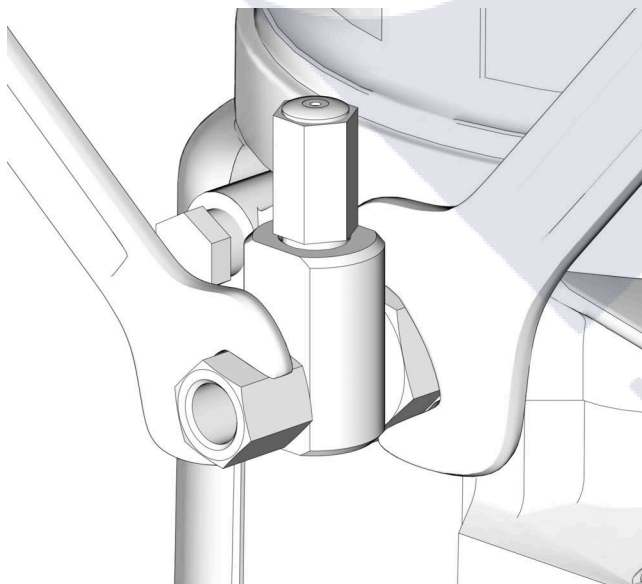

FIG. 10

Connecting to Auxiliary Fittings



NOTICE

Do not attach unsupported equipment to auxiliary fittings such as fill ports and pump element. Attaching unsupported equipment to these fitting can result in irreparable housing damage.

- Always use two wrenches working in opposite directions when connecting anything to pump element or auxiliary fittings. See FIG. 10 for an example.
- Torque pump element fittings to 50 in. lbs (5.6 N•m).
- When connecting pump element into housing torque to 50 in. lbs (5.6 N•m).

Pressure Relief Valves



To prevent over-pressurization, which can result in equipment rupture and serious injury, a pressure relief valve appropriate for the lubrication system must be installed close to every pump outlet to alleviate unintended pressure rises in the system and protect the G3 pump from damage.

- Only use a pressure relief valve that is rated for no more than the working pressure of any component installed in the system. See Technical Data, page 45.
- Install a pressure relief valve close to every pump outlet; before any auxiliary fitting.

NOTE: A pressure relief valve can be purchased from Graco. See Parts, page 48.

Setting Pump Outlet Volume

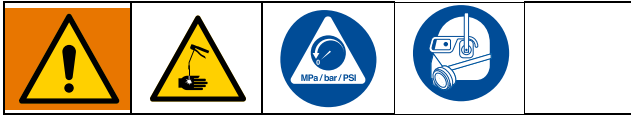

NOTE:

- Before making any adjustments to pump volume, **Relieve Pressure** following procedure on page 17.
 - Only use Graco supplied spacers to control output volume.
1. Use a wrench to turn pump element counter-clockwise to loosen. Do not remove entire pump element. Only back pump element out enough to allow spacer to be slid on or off.
 2. If needed, remove or insert spacers to achieve required pump output volume. A tool may be needed to facilitate removal.

Pump volume control is set using either no (0) spacers, 1 or 2 spacers (FIG. 11).

Do not use more than 2 spacers to adjust output volume.

No. Spacers	Output Volume / Minute	
	cubic inches	cubic cm
2	0.12	2
1	0.18	3
0	0.25	4

NOTE:

- The amount of dispensed volume can vary depending on external conditions such as lubricant temperature and back pressure from downstream connections.
- Use of these volume adjustment in conjunction with setting the ON time of the pump will allow for control of the output volume.
- Use these volume adjustments as a starting point and adjust as necessary to ensure desired lubrication dispense.
- Tighten pump element fitting. Torque fitting to 50 in. lbs (5.6 N•m).

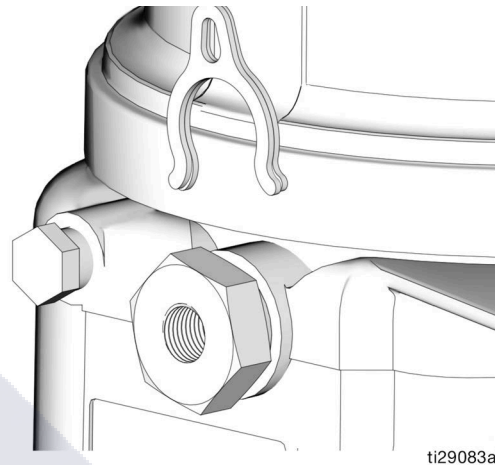

FIG. 11

Loading Grease

To ensure optimal performance from the G3:

- Only use NLGI #000 - #2 greases appropriate for your application, automatic dispensing, and the equipment's operating temperature. Consult with machine and lube manufacturer for details.
- The reservoir can be filled using a hand operated pump, pneumatic pump or electric transfer pump.
- Do not overfill (FIG. 14).
- Do not operate G3 without reservoir attached.

NOTICE

- Always clean inlet fitting (D) (FIG. 12) with a clean dry cloth prior to filling reservoir. Dirt and/or debris can damage pump and/or lubrication system.
- Care must be used when filling the reservoir using a pneumatic or electric transfer pump to not pressurize and break the reservoir.

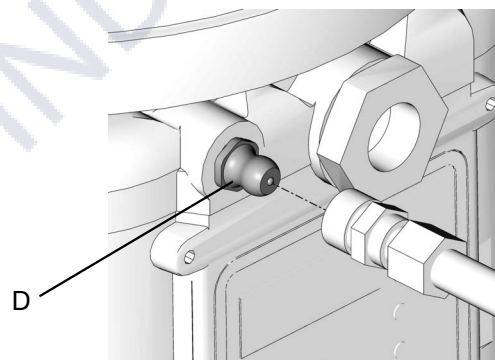
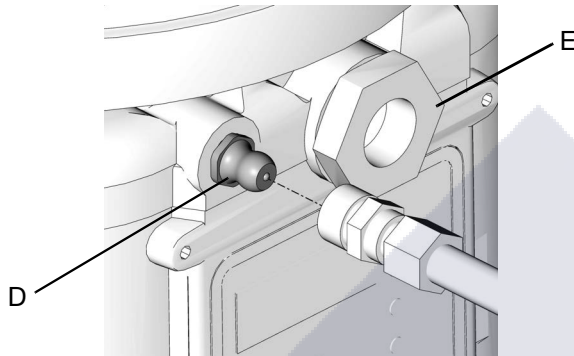

FIG. 12

Models without a follower plate:

1. Connect fill hose to Zerk inlet fitting (D) (FIG. 13).

**FIG. 13**

2. For higher viscosity fluids, start pump to rotate stirring paddle during fill to prevent air pockets from forming in grease.

Start pump by pressing the manual run button.



3. Fill reservoir with NLGI grease to max fill line.

NOTE: Vent port, located in rear of reservoir, should not be used as an overfill port/indicator.

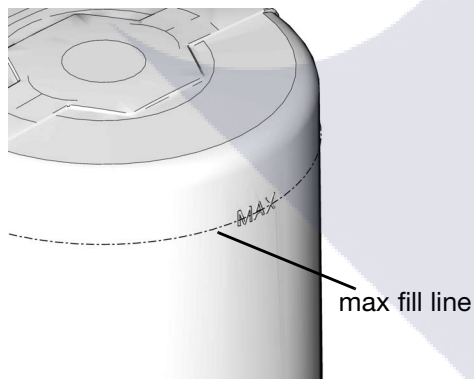
**FIG. 14**

4. Remove fill hose.

Models with Top Fill**MOVING PARTS HAZARD**

Moving parts can pinch, cut or amputate fingers and other body parts.

- Keep clear of moving parts.
- Do not operate equipment with lid removed.
- Disconnect power before removing lid.

1. Disconnect the power from the equipment.

NOTE: If battery disconnect is not available, remove the power cord (FIG. 15).

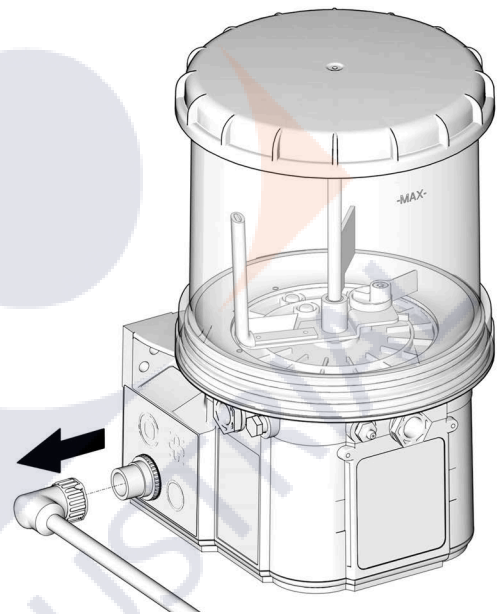
**FIG. 15**

2. Clean the top of the lid and the area around the top of the reservoir to ensure that no debris falls into the reservoir when the lid is removed.
3. Turn the lid counterclockwise to remove.
4. Place the lid in a clean area to avoid debris getting into the inside of the lid or threads.
5. Fill the reservoir with new clean grease.
6. Make sure that no contaminants enter the reservoir.

NOTICE

Any debris or dirt accidentally introduced into the reservoir should be removed immediately. Do not allow the pump to operate until any debris or dirt are removed.

Operating the pump with debris or dirt in the reservoir, may damage the pump, down stream equipment, and bearings.

7. Clean the threads on the reservoir and the lid.
8. Replace the lid onto the reservoir, turning clockwise (approximately 1 3/4 turns).
9. Reconnect the power to the equipment.

Models with a follower plate:

1. Connect fill hose to Zerk inlet fitting (D) (FIG. 13).
2. For higher viscosity fluids, start pump to rotate stirring paddle during fill to prevent air pockets from forming in grease.

Start pump by pressing the manual run button.



3. Fill reservoir with grease until seal of follower plate breaches the vent hole (FIG. 16) and the majority of air is expelled from the reservoir.

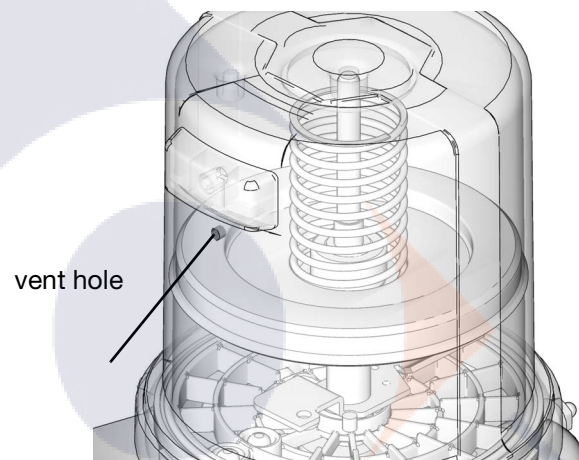

FIG. 16

NOTE: Vent port, located in rear of reservoir, should not be used as an overfill port/indicator.

4. Remove fill hose.

Changing Greases

When changing greases, always use compatible fluids or greases.

Auto-Fill Shut Off

Load Grease

To ensure optimal performance from the G3:

- Only use NLGI #000 - #2 greases appropriate for your application, automatic dispensing, and the temperature. Consult with machine and lube manufacturer for details.
- Do not overfill.
- Do not operate G3 without reservoir attached.

NOTICE

Care must be used when filling the reservoir using a pneumatic or electric transfer pump to not pressurize and break the reservoir.

Change Greases

When changing greases, always use compatible fluids or greases.

The Auto-Fill Shut Off is used for refilling the G3 reservoir in an automatic lubrication system. As fluid is added to the reservoir, it pushes the plate valve up to the top of the reservoir. The plate valve then pushes the valve pin and closes the inlet fluid path.

When the fluid refilling path closes, the refilling line pressurizes and brings the refilling pump to a pressurized stall condition.

NOTE: The operator must monitor system while filling the reservoir to prevent overfilling.

Remote Fill with Remote Fill Manifold



The remote filling station pump stalls (dead-heads) when the reservoir is full, causing the supply system pressure to rise to the maximum output pressure of the filling station pump. To help prevent equipment damage or serious injury caused by pressurized fluid, such as skin injection or injury from splashing fluid, always use a remote filling station pump with a maximum output pressure of 5100 psi (35.1 MPa, 351.6 bar) and use supply hoses with a minimum pressure rating of 5100 psi (35.1 MPa, 351.6 bar).



COMPONENT RUPTURE HAZARD

The maximum working pressure of each component in the system may not be the same. To reduce the risk of over-pressurizing any component in the system, be sure you know the maximum working pressure of each component. **Never** exceed the maximum working pressure of the lowest rated component in the system. Over-pressurizing any component can result in rupture, fire, explosion, property damage and serious injury.

Regulate input pressure to the remote fill pump so that no fluid line, component or accessory is over pressurized.

The reference letters used in the following instructions refer to the Typical Installation diagram, page 10.

The fill valve is used to relieve pressure in the refill line and to reset the Auto Fill Shut Off. See Fill Valve instruction manual 333393. Graco fill valve, part no. 77X542 is available. Contact your local Graco distributor.

1. Pull out and hold the Pressure Relief Knob (T) long enough to relieve line pressure between Fill Manifold (N) and Auto-Fill Shut Off Valve (B).
2. Verify the Auto-Fill Shut Off (B) pin is down, indicating it is reset (FIG. 17).

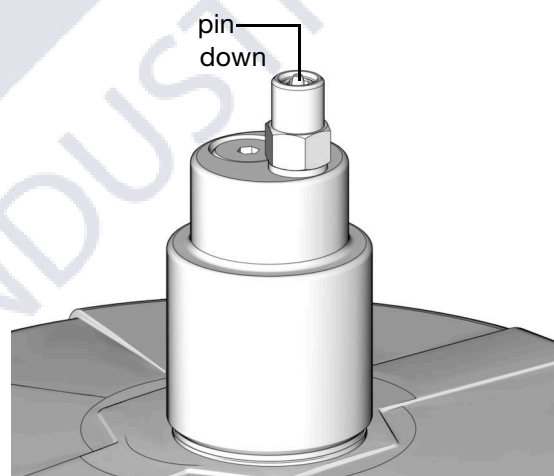

FIG. 17

ti28218a

3. Remove yellow Dust Cover from Fill Coupler (M).

4. Connect Supply Hose (J) between the Remote Filling Station Pump (F) and Fill Coupler port marked with an "I".
5. Start Remote Filling Station Pump (F).
6. When the G3 Reservoir (D) is filled:
 - the Remote Filling Station Pump (F) stalls (dead-heads),
 - the Auto-Fill Shut Off (B) pin pops up as shown in FIG. 18,
 - the Pressure Gauge (R) rises to the fill pump's set pressure.

NOTE: If the pump does not stall (dead-head) there is a leak in the system.

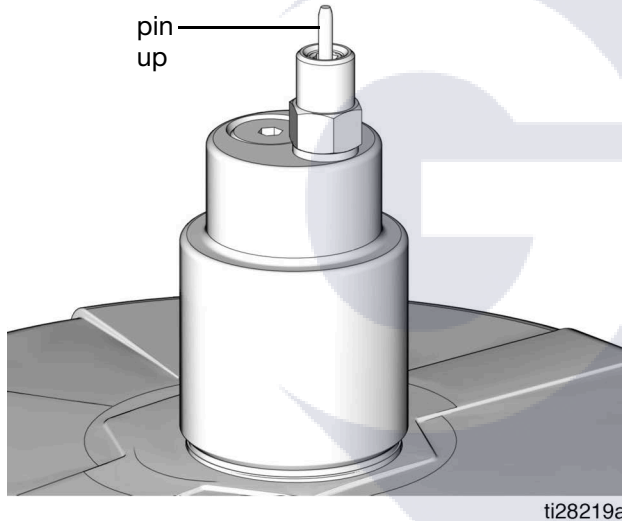

FIG. 18

7. Turn off the Remote Filling Station Pump (F).
8. Pull out and hold the Pressure Relief Knob (T) long enough to relieve line pressure between Fill Manifold (N) and Auto-Fill Shut Off Valve (B) and between Remote Filling Station Pump (F) and Fill Manifold (N).

NOTE: The length of time it takes to vent varies depending on the system design and installation. In some installations it may be necessary to repeat Step 8 to ensure pressure is relieved.

9. Disconnect Supply Hose (J) at Fill Coupler (M).
10. Replace yellow Dust Cover over Fill Coupler (M).

Remote Fill without Remote Fill Manifold

The reference letters used in the following instructions refer to the Typical Installation diagram, page 11.

1. A supply hose pressure relief valve (Y) and overflow container (W) (for collecting excess fluid that drains during pressure relief) **must** be installed in an easily accessible location between the remote filling station pump (F) and the Auto-Fill Shut Off (B). This pressure relief valve is used to relieve pressure in the refill line and to reset the Auto-Fill Shut Off. See Typical Installation, starting on page 9.

A Pressure Relief Kit: 247902 is available from Graco. Contact your distributor or Graco Customer Service for additional information about this kit.

2. Connect Supply Hose (J) at Quick Connect (V).
3. Turn on remote filling station pump (F) and fill the G3 reservoir (D) until the indicator pin on the Auto-Fill Valve pushes up as shown in FIG. 19. The pressure in the refill pump (F) builds and the pump stalls.

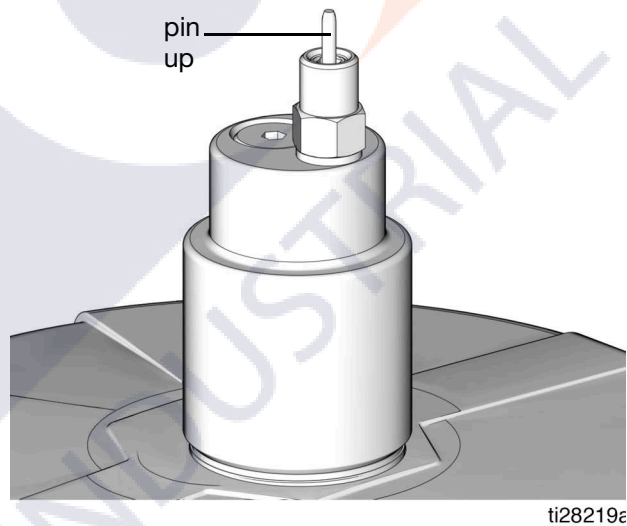

FIG. 19

4. Turn off the air supply (H) to pump (F).
5. Relieve remote filling station pump pressure using the following Remote Filling Station Pressure Relief procedure:

Remote Filling Station Pressure Relief

The reference letters used in the following instructions refer to the Typical Installation diagrams starting on page 9.



The following Pressure Relief Procedure is only used with the Auto-Fill Shut Off Valve to relieve remote filling station and lubricant supply line pressure.

This equipment stays pressurized until pressure is manually relieved. To help prevent serious injury from pressurized fluid, such as skin injection, splashing fluid and moving parts, follow the Pressure Relief Procedure when you stop dispensing and before cleaning, checking, or servicing the equipment.

- a. To relieve pressure between the Refill Pump (F) and Auto-Fill Shut Off (B), open ball valve (bv) (FIG. 20). Pressure will be released and excess fluid will drain out of the drain tube (L) and into the lubrication overflow container (W).

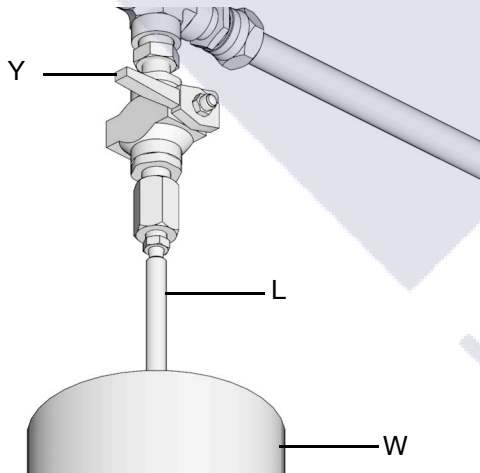

FIG. 20:

- b. Close supply hose pressure relief valve (Y) when all pressure has been relieved.
6. Disconnect the supply hose (J) from Quick Connect (V).

Fill Oil Unit

- Only use oil appropriate for your application, automatic dispensing, and the equipment's operating temperature. Consult with machine and lube manufacturer for details.
- Do not overfill (FIG. 21).
- Do not operate G3 without reservoir attached.
- Only use oils with viscosity at least 40 cSt.

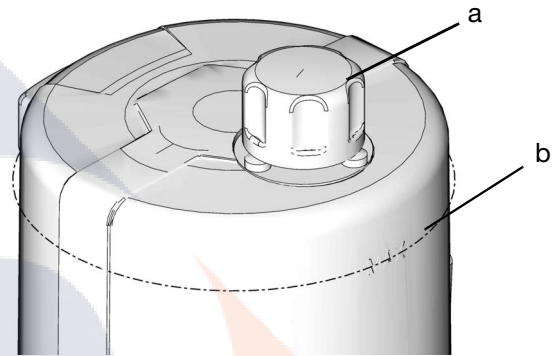

FIG. 21

1. Remove fill cap (a).
2. Pour oil into reservoir to max fill line (b).
3. Replace fill cap. Hand tighten cap, securely.

Prime the pump

NOTE: It is not necessary to prime pump every time pump is filled with lubricant.

Pump only requires priming the first time it is used or if it is allowed to run dry.

1. Loosen pump element fitting (FIG. 22).

NOTE: When loosening pump element fitting, do NOT loosen **pump element**. Loosening pump element will change the output volume

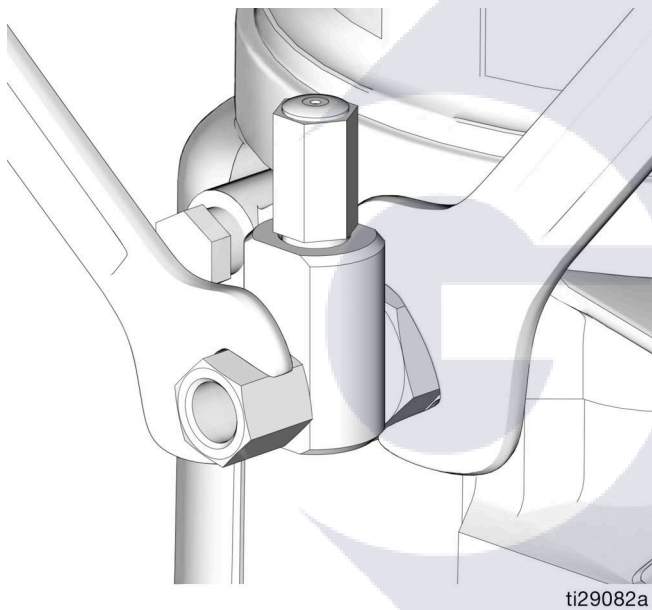

FIG. 22

2. Only run pump until air is no longer dispensed with the lubricant coming out of element fitting (FIG. 23).

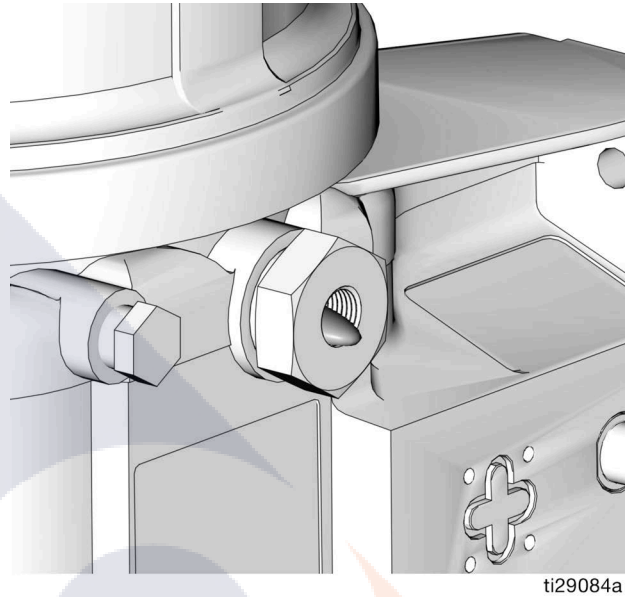
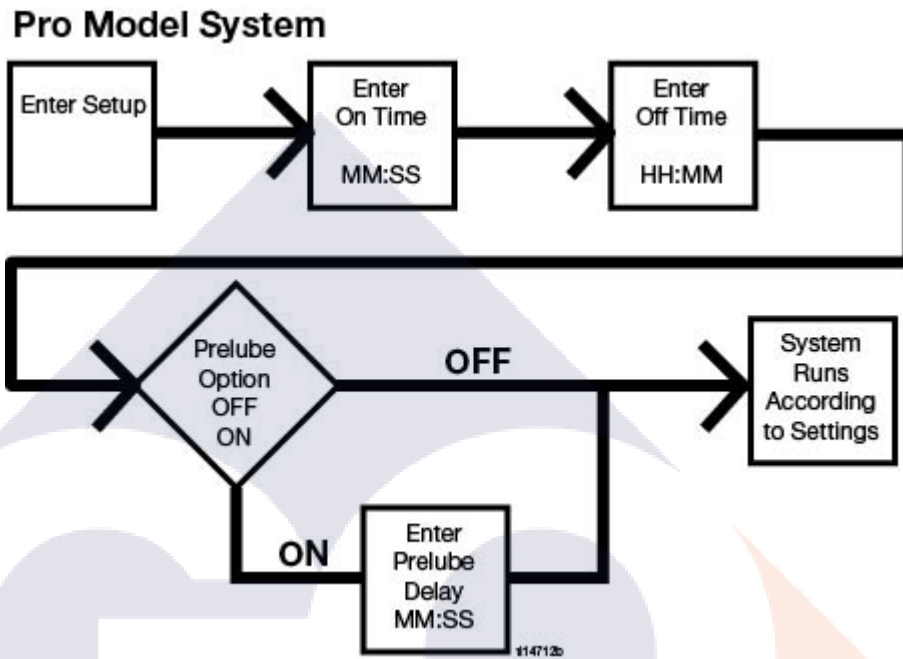

FIG. 23

3. Tighten pump element fitting using two wrenches working in opposite directions (FIG. 22).

Quick Setup Guide



Pro Model Setup

Control Panel Overview (FIG. 24)

NOTE: Programming instructions begin on page 27.

DISPLAY

- A blinking LED under HH, MM, SS or ## indicates type of measurement unit you are setting; i.e., HH is hours.
- A blinking number on the display indicates the G3 is in SETUP MODE.
- In RUN MODE displayed numbers count up or down. See Time ON and Time OFF.

OFF TIME

- LED lights when OFF Time sequence is running.
- Value is entered in HH:MM.
- Displays in HH:MM (hours and minutes) when > 1 hour.
- Displays in MM:SS (minutes and second) when < 1 hour.

ON TIME

- LED lights when ON Time sequence is running.
- Display shows time as MM:SS (minutes and seconds). i.e., 08:30 is 8 minutes: 30 seconds.
- Times lubrication cycle.
- Counts down from a set time to zero.

LEFT DIRECTION ARROW / RESET

- In SETUP MODE: moves cursor in display one field to the left.
- In RUN MODE: single press clears warning.
- In RUN MODE: pressing for one second ends run cycle if there are no warnings.
- In ALARM MODE: pressing and holding for 3 seconds clears fault / warning and switches cycle to OFF MODE.

UP and DOWN ARROW

- Hold both the UP and DOWN ARROW buttons down together for 3 seconds to enter SETUP MODE.
- In SETUP MODE, increases or decreases number values shown in display.

ALARM ICONS

LED next to icon lights when a fault / warning event occurs during a run cycle. See page 39 for a complete description of these alarm scenarios.

LOCK ICON

• LED next to icon lights indicating PIN is required to enter setup.

• In SETUP MODE LED lights when setting up the PIN.

PRELUBE

LED next to icon lights indicating Prelube function is enabled.

RIGHT DIRECTION ARROW / MANUAL RUN / ENTER:

- In SETUP MODE: saves entry, moves cursor in display one field to the right or to the next setup step.
- In RUN MODE: starts a manual run cycle.

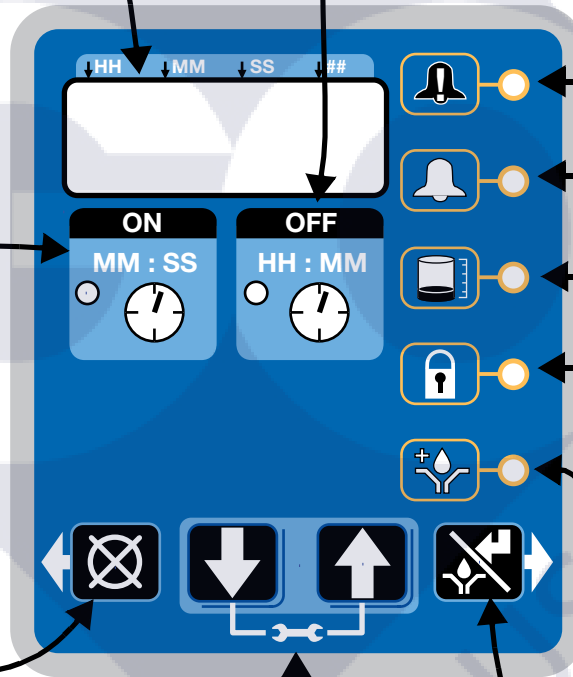

FIG. 24

Instructions

Check the Firmware Version

To check the firmware version installed on the pump:

1. Remove power to the pump by disconnecting the power cable from the connection.
2. Reconnect the power cable to the power connection.

This creates a power cycle and the firmware version displays on the screen during the first few seconds of power up. See FIG. 25.



FIG. 25

Powering Units With Controllers

By default, units with controllers are set to operate in a timed mode with 1 minute of ON time and 8 hours of OFF time. The unit should be powered up in OFF mode, counting down from the 8 hours. If the unit powers up in ON mode and has not been primed, hold the reset button located on the control panel (example shown on the right) for 1 second to move to the OFF mode.



The Pro Model uses a timer to regulate how long a pump cycle runs and the length of time the pump rests between cycles.

NOTE:

- A blinking number on the display indicates the G3 is in SETUP MODE.
- In RUN MODE numbers on the display do not blink.
- After 60 seconds of no activity, the device returns to RUN MODE in the OFF Time cycle and the OFF Time restarts counting down the total programmed amount of time. It does **not** resume the countdown from the point where the cycle was interrupted when you entered SETUP MODE.

Entering Setup Mode

Press both the UP and DOWN ARROW buttons together for 3 seconds to enter the SETUP MODE.



NOTE: If the lock LED is lit after entering Setup Mode and four 0000's are displayed, the unit has a PIN Code lock out enabled. See Entering a PIN Code to Access Setup Mode for instructions on entering a value.

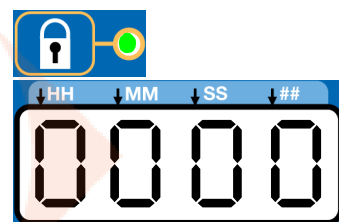

Entering a PIN Code to Access Setup Mode

The G3 controller does not require a user to provide a PIN code to access the programming features of the unit. However, Graco understands that some users may want to protect the program settings and therefore, an option for adding PIN Code authorization is available. The instructions for setting a PIN Code are provided in the Advanced Programming section of this manual. See page 32.

To enter the PIN Code:

1. Press both the UP and DOWN ARROW buttons for 3 seconds.
2. The LED next to the LOCK ICON on the display lights and the 4 zeros appear on the display indicating the system requires a PIN Code entry to access the G3 in SETUP MODE.

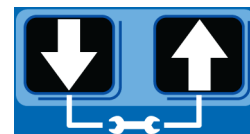

- The cursor is automatically positioned to enter the first character of the PIN Code. Use the UP and DOWN ARROW buttons to move up and down through the numbers 0-9 until the first number in the PIN code is displayed in the field.



- Press the ENTER button to set the number. The cursor automatically moves to the next number field.



- Repeat steps 3 and 4 for each PIN Code prompt field.

If the PIN Code you entered is correct, the first editable character on the display will flash.

NOTE: A blinking field on the display indicates the G3 is in SETUP MODE. In RUN MODE numbers on the display will not blink.

ON Time

- The LED next to the clock in the ON field lights, indicating you are setting the ON Time parameters.



- ON Time is set in Minutes and Seconds (MM: SS).

- An LED flashes under either MM when programming minutes **OR** SS when programming seconds.

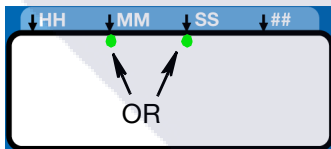

- In SETUP MODE, the number displayed in the first field, on the left side of display blinks, indicating the device is ready to program the ON Time minutes.

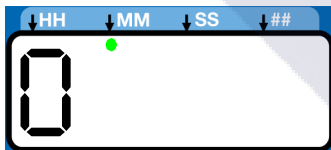

- The total amount of ON Time cannot exceed 30 minutes. If a value greater than 30 minutes is entered, the RED alarm LED lights and the value must be updated.



If this time does not meet the application needs, contact Graco Customer Support.

Programming ON Time

NOTE: When programming a time of less than 10 minutes you **must** program a leading zero in the first number field and press the ENTER button to save the zero selection.

- To set the ON Time use the UP or DOWN ARROW button to scroll through numerals 0 to 5 until the desired number appears in the first MM (minutes) field.

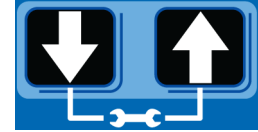

- Press the ENTER button to lock in the selection. The next MM number field to the right flashes indicating it is ready for programming.



- Use the UP or DOWN ARROW button to scroll through numerals 0 to 9 until the desired number appears in the second MM number field.

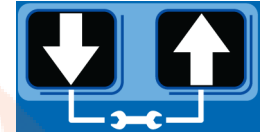

- Press the ENTER button to lock in the selection.



The next number field to the right flashes and the LED lights under SS; indicating it is ready to program the seconds fields.

- Repeat steps 1 - 4 to set the SS (seconds) fields.
- After pressing the ENTER button to set the last SS field, all the programmed ON Time information is saved.



The G3 automatically switches to the OFF Time SETUP MODE.

OFF Time

- The LED next to the clock in the OFF field lights, indicating you are setting the OFF Time parameters.



- OFF Time is set in Hours and Minutes (HH: MM).

- An LED flashes under either HH when programming hours **OR** MM when programming minutes.

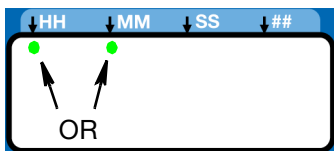

- In SETUP MODE the number displayed in the first field, on the left side of display blinks, indicating the device is ready to program the OFF Time hours.



- The total amount of OFF Time must be at least twice as long as the programmed ON Time. If a value less than twice the ON Time is entered, the RED alarm LED lights and the value must be updated.



If this time does not meet the application needs, contact Graco Customer Support.

Programming OFF Time

NOTE: When programming a time of **less than 10 hours** you **must** program a leading zero in the first number field and press the ENTER button to save the zero selection.

- To set the OFF Time use the UP or DOWN ARROW button to scroll through numerals 0 to 9 until the desired number appears in the first HH (hour) field.



- Press the ENTER button to lock in the selection. The next HH number field to the right flashes indicating it is ready for programming.



- Use the UP or DOWN ARROW button to scroll through numerals 0 to 9 until the desired number appears in the second HH number field.



- Press the ENTER button to lock in the selection.



The next number field to the right flashes and the LED lights under MM; indicating it is ready to program the minutes fields.

- Repeat steps 1 - 4 to set the next MM (minutes) fields.
- After pressing the ENTER button to set the last MM field, the OFF Time information is saved.



Prelube

The Prelube function determines operation of the pump when power is applied. It can be set to OFF or ON.

OFF (default) - The unit resumes its lubrication cycle at the point it was at when power was removed.

ON - The unit begins a pump cycle.

Setting Prelube

- After you set the OFF Time information and press the ENTER button, the G3 automatically switches to the Prelube setup.

Notice the LED next to the prelube icon on the G3 display lights indicating you are now in the Prelube setup mode.



- OFF displays. If you want the prelube cycle to begin immediately, leave this set to OFF.



- Press the ENTER button to set the selection.



- If you want to set a prelube delay time, press the DOWN ARROW button to change OFF to ON on the display.

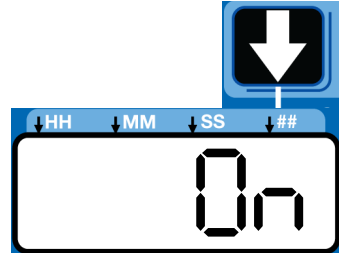

Prelube Delay

Prelube Delay can be entered to delay the start of the pump's cycle on power up. If prelube is set to ON, a prelube delay time in MM:SS must be entered. By default, the delay is set to 0 (begin an ON cycle immediately).

Delaying the prelube function may be desired if other critical functions or systems of your machine or vehicle are also coming on line during power up.

1. Prelube Delay is set in MM:SS (minutes and seconds). To set the time use the UP or DOWN ARROW button to scroll through numerals 0 to 5 until the desired number appears in the first MM (minutes) field.

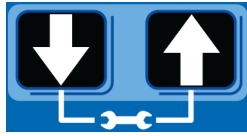

The maximum length of time Prelube Delay can be set to is 59:59 (59 minutes:59 seconds).

2. Press the ENTER button to lock in the selection. The next MM number field to the right flashes indicating it is ready for programming.



3. Use the UP or DOWN ARROW button to scroll through numerals 0 to 9 until the desired number appears in the second MM number field.



4. Press the ENTER button to lock in the selection.



The next number field to the right flashes and the LED lights under SS; indicating it is ready to program the seconds fields.

5. Repeat steps 1 - 4 to set the SS (seconds) fields.

6. After pressing the ENTER button to set the last SS field the G3 automatically switches to the RUN MODE.



Advanced Programming

There are several Advanced Programming options. The following Table identifies each option and when it is used.

Advanced Option	Setting	Format/ Description	Why Use This?
A1	Lockout Code (Optional)	Secures setup modes with PIN	Prevents unauthorized users to adjusting settings.
A2	Low Level Alarm Time	MM:SS (minutes:seconds) sets amount of time between Low Level Warning to Low Level Fault. Default = 3 minutes	To accommodate most lubrication situations, a conservative amount of time is programmed between the low level warning and fault to help protect unit from running dry. If necessary the amount of time the unit runs before stopping due to a low level fault can be adjusted.
A5	Active Alarm	Changes alarm output behavior. Default = OFF	Uses alarm output to determine if a unit has an alarm AND/OR loses power. The output turns ON when power is applied. It turns OFF when power is lost or an alarm occurs. Normal operation (OFF) will only activate alarm output in an alarm condition when power is on. Can change (set to ON) to activate alarm with power ON and deactivate with power OFF OR warning. Used to manage power outage.
A7	Constant Alarm Output on Fault	Changes alarm output behavior. Default = OFF	This function changes the behavior of the alarm output in a fault from either toggling once every second or steady on.
Firmware 5.01 and later			
A8	4 Digit Hour Off Time	Changes maximum OFF time. Default = OFF	This function changes OFF time from HH:MM to HHHH. It allows a maximum of 9999 hours of OFF time.
Firmware 5.04 and later			
A10	Low Level Reset Upon power ON	Changes low level fault upon power ON. Default = OFF	This function changes the behavior of the low level fault upon power ON.
A11	Warning OFF through alarm relay	Changes alarm output behavior. Default = OFF	This function changes the behavior of the alarm output in a warning condition to always OFF.
Firmware 5.06 and later			
A12	Prelube Sequences	Changes the number of the Prelube sequences.	This function changes the behavior of the prelube function to add more lubrication sequences upon pump start up.
A13	MM:SS Off Time	Changes the OFF time programming from HH:MM to MM:SS Default = OFF	This function changes the programming of the OFF time.

Entering a PIN Code for the First Time

A1-Setting Up PIN Code

A PIN Code can be programmed into the G3 to protect the settings from inadvertently being changed by unauthorized users.

1. Press the UP ARROW button for 10 seconds.



The LED next to the LOCK ICON on the display lights, indicating you have entered the PIN Mode.



2. The word OFF appears in the display. Press the UP or DOWN ARROW button to change this to ON.



3. Press the ENTER button to enter the PIN Code.



4. The cursor automatically is positioned to entered the first character of the PIN Code. Use the UP and DOWN ARROW buttons to move up and down through the numbers 0-9 until the first number in the PIN code is displayed in the field.



5. Press the ENTER button to set the number. The cursor automatically moves to the next number field.



6. Repeat steps 4 and 5 for each PIN Code prompt field.

7. Press the ENTER button to save the PIN Code and exit Advanced Setup.



Entering Advanced Setup

Press the UP ARROW button for 10 seconds.



If the G3 was previously set up to require a PIN Code, the LED next to the LOCK ICON lights, indicating a PIN Code is required.

1. The cursor is automatically positioned to enter the first character of the PIN Code. Use the UP and DOWN ARROW buttons to move up and down through the numbers 0-9 until the first number in the PIN code is displayed in the field.

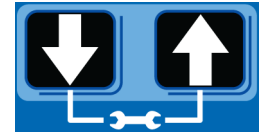

2. Press the ENTER button to set the number. The cursor automatically moves to the next number field.



3. Repeat steps 1 and 2 for each PIN Code prompt field.

If the PIN Code you entered is correct, the first editable character on the display will flash.

Selecting Advanced Setup Options

1. Press the UP or DOWN ARROW button to move up or down through Advanced Options A1 and A2.

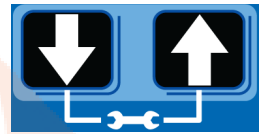

2. Press the ENTER button to set the selection.



A2 - Low Level Alarm Time *Pump ON mode only.*

Programs the amount of time in MM: SS (minutes and seconds) the pump can run between a Low Level Warning and a Low Level Fault to help protect unit from running dry.

The maximum recommended length of time is 3:00 minutes.

Fault, and Low Level LED illuminate.



FIG. 26

NOTE: When programming a time of less than 10 minutes you **must** program a leading zero in the first number field and press the ENTER button to save the zero selection.

1. To set the time use the UP or DOWN ARROW button to scroll through numerals 0 to 9 until the desired number appears in the first MM (minutes) field.



2. Press the ENTER button to lock in the selection. The next MM number field to the right flashes indicating it is ready for programming.



3. Use the UP or DOWN ARROW button to scroll through numerals 0 to 9 until the desired number appears in the second MM number field.



4. Press the ENTER button to lock in the selection.



The next number field to the right

flashes and the LED lights under SS; indicating it is ready to program the seconds fields.

5. Repeat steps 1 - 4 to set the SS (seconds) fields.
6. After pressing the ENTER button to set the last SS field, all the programmed ON Time information is saved.



Unit exits Advanced Programming.

A5 - Active Alarm

Changes the alarm output behavior. Uses output to determine if a fault has occurred.

Fault and ON LED's illuminate.

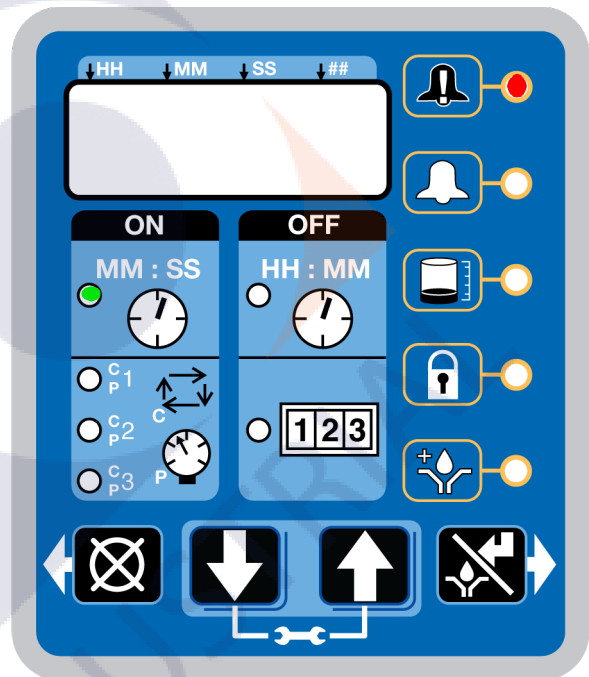
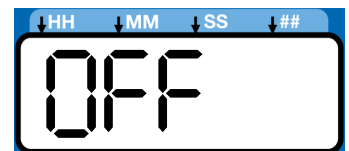

FIG. 27

1. The default OFF displays.



2. Press the UP or DOWN ARROW button to change OFF to ON on the display to activate alarm condition.



3. Press the ENTER button to exit Advanced Programming.



A7- Constant Alarm Output ON Fault

This function changes the behavior of the alarm output in a fault from either toggling once every second (default) or steady on.

Fault and Warning LEDs Illuminate



FIG. 28

1. The default OFF is displayed. The alarm output will toggle once a second.

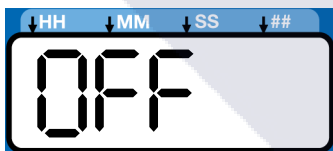

2. Press the UP or DOWN ARROW to change OFF to ON on the display to change the alarm output to be on steady



3. Press the ENTER button to exit Advanced Programming.



Models with Firmware 5.01 and later

A8 - 4 Digit Hour OFF Time

Changes the OFF time from HH:MM to HHHH. Allows for a maximum of 9999 hours of OFF time.

OFF LED illuminates.

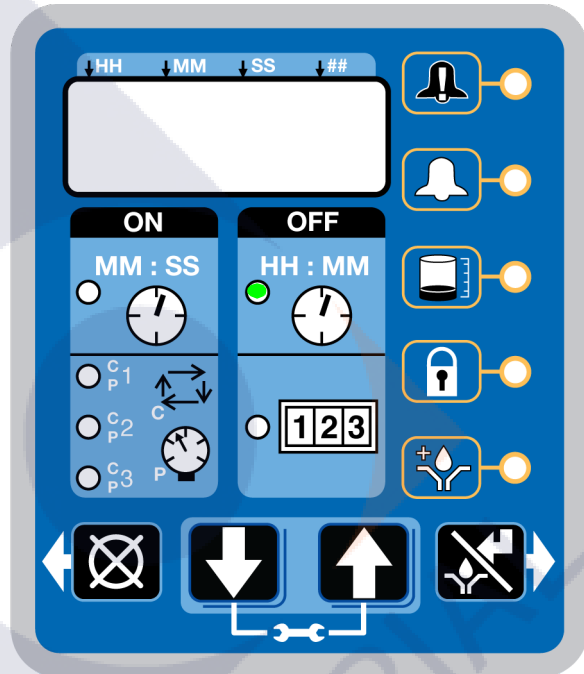
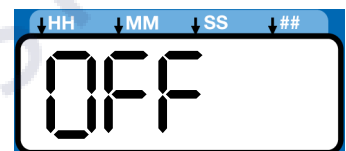

FIG. 29

1. The default OFF displays.



2. Press the UP or DOWN ARROW button to change OFF to ON on the display to activate alarm condition.



3. Press the ENTER button to exit Advanced Programming.



Models with Firmware 5.04 and later.

A10 - Low Level Reset Upon Power On.

This function changes the behavior of the low level upon pump power on. When A10 is on, a low level fault clears when the pump power is cycled. The pump will revolve 5 revolutions, checking to see if the low level condition is still present. If not, it will self clear and continue. If a low level condition exists during the 5 revolutions, it will go into a low level fault.

Low Level ON LED illuminates (Fig. 30).



FIG. 30

1. The default OFF is displayed. The alarm output will toggle once a second.

OFF

2. Press the UP or DOWN ARROW button to change OFF to ON on the display to change the low level reset upon power on.



3. Press the ENTER button.



A11- Warning Off Through Alarm Relay

This function changes the behavior of the alarm output in a warning condition to always off.

Fault and Warning LEDs Illuminate



FIG. 31

1. The default OFF is displayed. The alarm output will turn on during a warning condition.

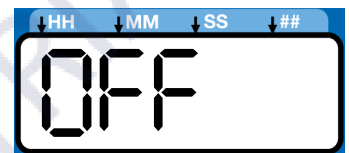

2. Press the UP or DOWN ARROW to change OFF to ON on the display to change the alarm output to be off during a warning condition.



3. Press the ENTER button to exit Advanced Programming.



Models with Firmware 5.06 and later.

A12 - Prelube Sequences

This function changes the behavior of the prelube function to add more lubrication sequences upon pump start up. While running multiple sequences, after the initial sequence, PL:xx will be displayed showing how many sequences are left.

Note: if pump has option "08" and using a pressure switch with multiple sequences, a vent delay time must be programmed under Advanced Programming Option A3.

Prelube LED illuminates (FIG. 30)



FIG. 32

1. The default 0001 is displayed. When Prelube is on, it will run one sequence.
2. Press the UP or DOWN ARROW button until desired number of prelube sequences displays.

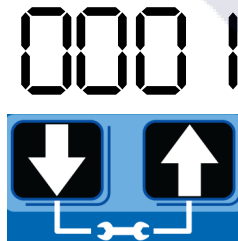

NOTE: When prelube is on, and the pump is powered-up, the pump will run this amount of lubrication ON sequences.

3. Press the ENTER button to exit Advanced Programming after the last digit of the pre-lube sequence is displayed.



A13- MM:SS OFF Time

This function changes the programming of the OFF Time.

OFF and Warning LEDs Illuminate



FIG. 33

1. The default OFF is displayed. OFF/Backup time in setup mode is displayed in HH:MM (Hours/Minutes).

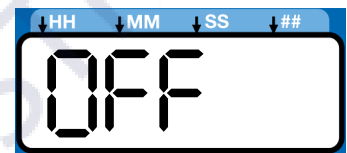

2. Press the UP or DOWN ARROW to change OFF to ON on the display. The OFF/Backup Time in setup mode will be displayed in MM:SS (Minutes/Seconds).



3. Press the ENTER button to exit Advanced Programming.



Run Mode

Time Control

After setup is complete, the G3 automatically begins to run the OFF Time sequence (FIG. 34).

- The G3 runs the programmed OFF sequence.
(Notice the OFF Time LED on the display lights and the OFF Time counts down on the display.)
- The example shown in FIG. 34 shows an OFF Time of 1 hour and 32 minutes before the lubrication cycle begins.



FIG. 34

- When the OFF Time count reaches zero, the G3 Automatic Lubrication Pump turns the pump on and it runs for the programmed ON Time cycle (FIG. 35).

(Notice the ON Time LED is now illuminated on the display.)

- The example shown in FIG. 35 shows an ON Time of 8 minutes and 42 seconds before the lubrication cycle ends.



FIG. 35

- When the ON Time count reaches zero, the pump shuts off again and the system again runs OFF Time cycle and the OFF Time LED is now again illuminated (FIG. 34).

This sequence repeats itself until the device is reprogrammed or an alarm occurs.

Manual Run Cycle



To run an extra (non-programmed) lubrication cycle, push the Manual Start button.

Additional Controls

Prelube / Prelube Delay

In all models a power OFF/ON cycle can be controlled with the Prelube and Prelube Delay functions.

Prelube

The Prelube function has been selected. Prelube delay is set to 00:00:

- Power to the unit cycles OFF then ON.
- Unit immediately begins a lubrication cycle.
- Pro Model - display shows ON Time (See Time Control, page 37).

Prelube Delay

The Prelube function has been selected. Prelube delay is set to something other than 00:00:

- Power to the unit cycles OFF then ON.
- Unit immediately begins the Prelube Delay count down until the lubrication cycle begins.
- The LED next to the clock in the OFF field is illuminated (FIG. 36).
- The Prelube LED lights (FIG. 36).
- The display shows time remaining until lubrication cycle begins. The example shown in FIG. 36 shows 8 minutes and 14 seconds left until a lubrication cycle begins.



FIG. 36

Manual Run Cycle



To run an extra (non-programmed) lubrication cycle, push the Manual Start button.

NOTE: Manual Run option is not available while unit is in Vent Mode.

Alarms: Firmware Versions 5.01 and Above

Any time a Fault / Warning occurs, a combination of LED's will illuminate to notify you there is a problem and help identify the kind of Fault / Warning has occurred. An error message will display and flash every 2 seconds for an alarm, temperature, or current warning, and every 10 seconds for all other types of warnings.

- Faults will not automatically clear. Warnings will clear after a set time, if condition was fixed.

- To clear an fault, press and hold the RESET button on the display button pad for 3 seconds.





- To clear a warning instantly press and immediately release the RESET button.





Fault / Warning Scenarios

The following pages describe the most likely fault / warnings you could receive.

Alarm Type	What it Looks Like	What it Indicates	Solution
Low Level Warning		<p>Level of lubricant in reservoir is low and additional lubricant needs to be added.</p> <p>Unit continues to operate as normal for a limited period of time until a low level alarm is triggered or until the reservoir is filled and 30 seconds have passed, at which time the warning will self-clear.</p>	<p>Add lubricant to reservoir.</p> <p>After lubricant is added, press the RESET button to clear the warning.</p>

<p>Low Level Fault</p>		<p>Level of lubricant in reservoir is low and additional lubricant needs to be added.</p> <p>Unit stops pumping and displays amount of accumulated time since the alarm was triggered.</p>	<p>Add lubricant to reservoir.</p> <p>After lubricant is added press and hold the RESET button to clear fault.</p>  <p>If repriming pump is required, the low level alarm time should be decreased. See A-2: Advanced Programming, Low Level Alarm Time page 32.</p>
<p>Motor Current Warning</p>		<p>The measured motor current is above the recommended operating maximum value. Continued use at excessive motor currents could reduce life or cause permanent damage.</p> <p>Warning will self-clear any time after 15 seconds On Time start if system correction is made.</p>	<p>Examine the system to make sure it is operating correctly. A blocked line could create excessive motor current.</p> <p>Examine the pump to ensure that it is rotating properly.</p> <p>If necessary, contact Graco Customer Service.</p>

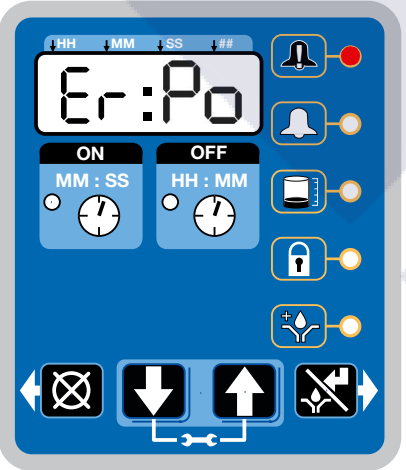
Fault/Warning Scenarios for Firmware Versions 5.06 and Later

Alarm type	What it Looks Like	What it Indicates	Solution
<p>Low Power Warning</p>		<p>If there is a voltage drop at the power source during operation, the pump will go into a low power warning condition.</p> <p>the unit will continue to operate for a total of 15 minutes before going into a Low Power Fault.</p> <p>Also, if the pump power cycles on power up for a minimum of 3 times, the pump will display a low power warning.</p> <p>If the warning condition clears itself, the warning is cleared and the unit continues operation.</p>	<p>Check voltage and available current output at the power source of the pump.</p>
<p>Low Power Fault</p>		<p>There is a low voltage condition at the power source.</p>	<p>Check voltage and available current output at the power source of the pump.</p> <p>Press and hold the RESET button to clear the fault.</p> 

Troubleshooting

Follow the **Pressure Relief** on page 17 before checking or repairing the equipment.



Problem	Cause	Solution
Unit does not power on	Incorrect/loose wiring	Refer to Installation instructions, page 8.
Unit does not power on (DC models only)	Tripped external fuse due to internal component failure	Contact Graco Customer Service.
	Tripped external fuse due to pumping non-cold weather lubricant in cold weather -13°F (-25°C)	Replace lubricant with pumpable lubricant, rated for environmental conditions and application. Replace fuse.
Unit does not power on (AC models only)	Tripped internal power supply fuse due to power supply failure	Contact Graco Customer Service.
Can't set desired ON/OFF times	Maximum duty cycle is 33% (2 minutes OFF for each minute ON)	Adhere to allowable duty cycle. Contact Graco Customer Support if other duty cycles are required for application.
Unit is not operating based on the time that was programmed	Time entered was misinterpreted as MM:SS instead of HH:MM (or visa versa)	Verify the unit was programmed as intended, referencing programming instructions. Note the dot designation for hours, minutes, seconds on the top row of the display.
Lubricant leaks past seal located on the bottom of the reservoir	Reservoir retaining tabs are cracked or broken	Replace reservoir.
	Reservoir is being pressurized during filling	Ensure vent hole is not plugged. If problem persists, contact Graco Customer Service or your local Graco distributor for assistance.
Unit not pumping during ON cycle, but controller lights and functions	Failed motor	Replace unit.
Follower plate is not going down	Air is trapped in the reservoir between the follower plate and lubricant	Add grease following Loading Grease instructions, page 18. Ensure air is purged.
Pump takes several minutes before it begins pumping at the highest pump volume setting (no stroke adjust spacers installed)	Pumping non-cold weather lubricant in cold weather -13°F (-25°C)	Add 1 stroke adjust spacer and adjust lube cycle time to accommodate the difference in pump volume per stroke.
Dim display, unit is not operating	Tripped internal, resettable fuse due to internal component failure or sensor short circuit condition	Verify sensor and manual run inputs have not created a short circuit condition. Cycle power.

Maintenance

Frequency	Component	Required Maintenance
Daily and at refill	Zerk Fittings	Keep all fittings clean using a clean dry cloth. Dirt and/or debris can damage pump and/or lubrication system.
Daily	G3 Pump Unit and Reservoir	Keep pump unit and reservoir clean using a clean dry cloth.
Daily	Display	Keep display clean using a clean dry cloth.
Monthly	External Wiring Harness	Verify external harnesses are secure.

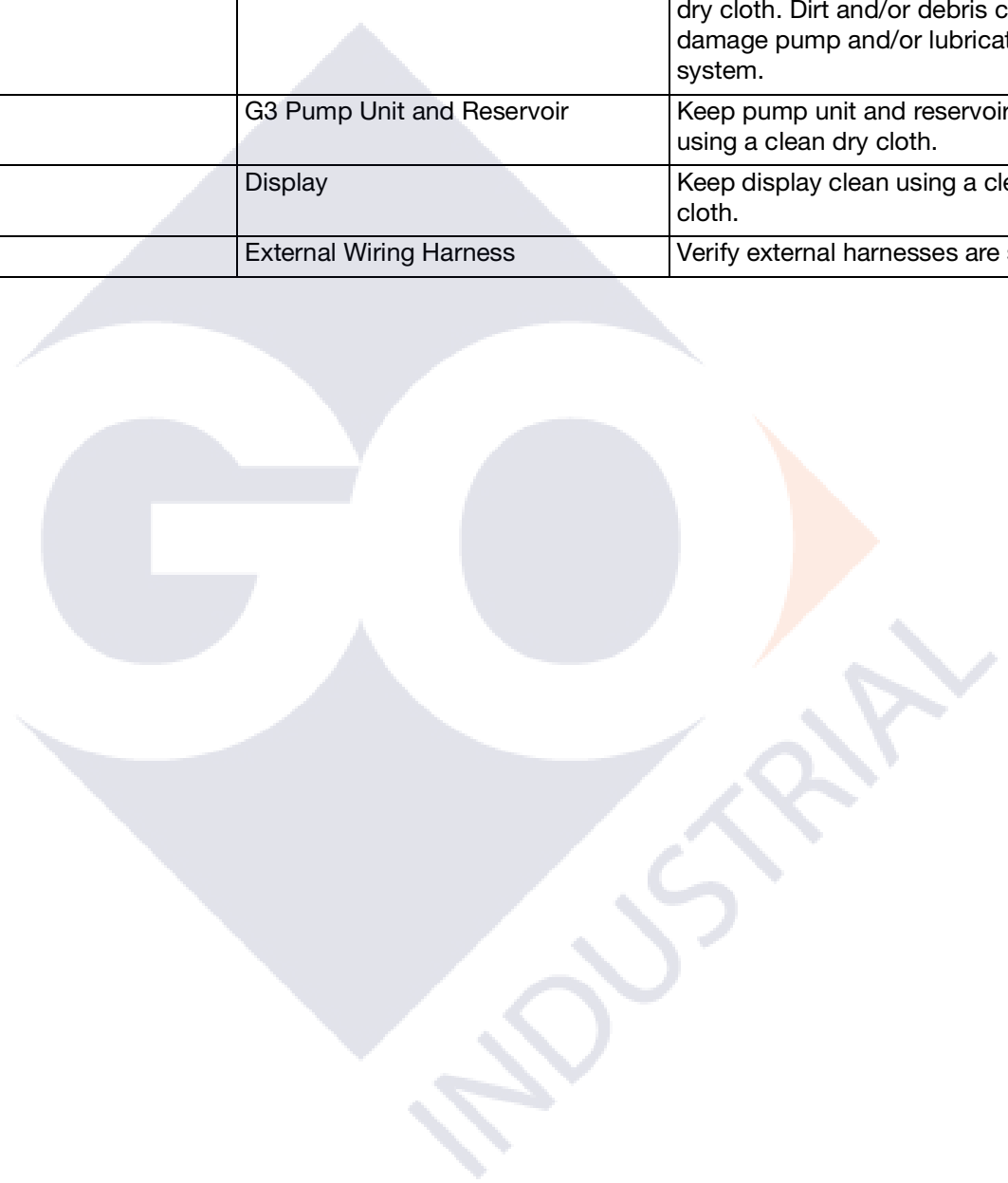

Parts - 2 Liter Models

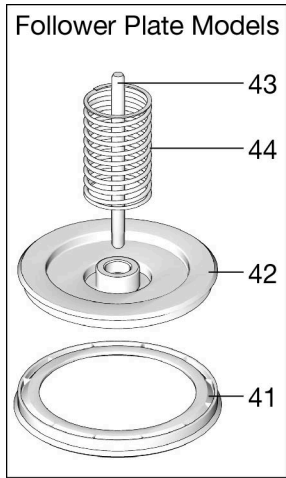

Oil Reservoir

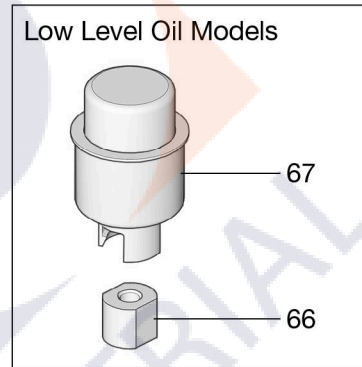
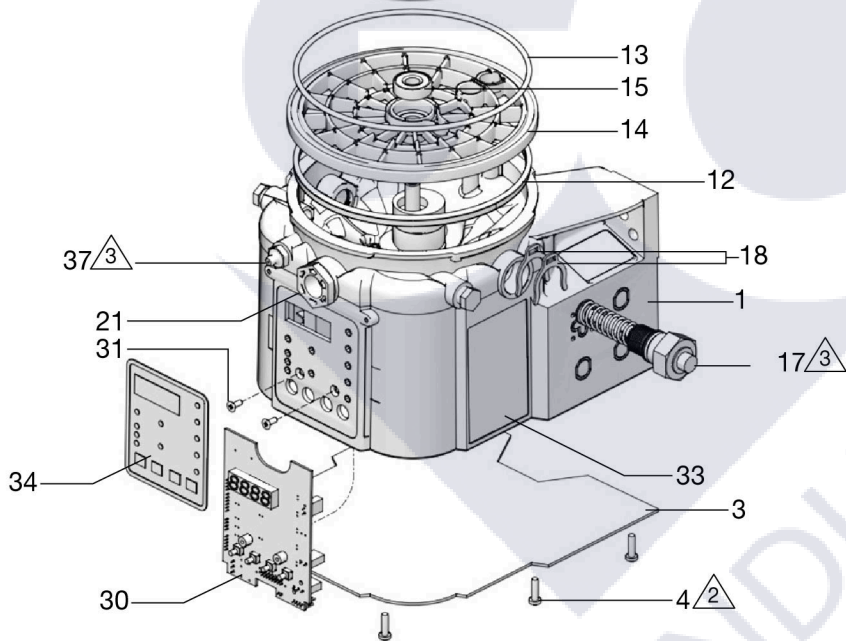
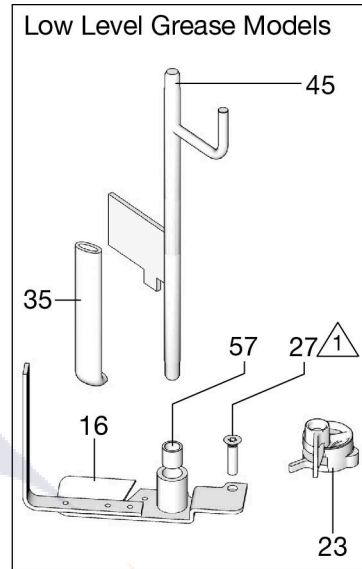
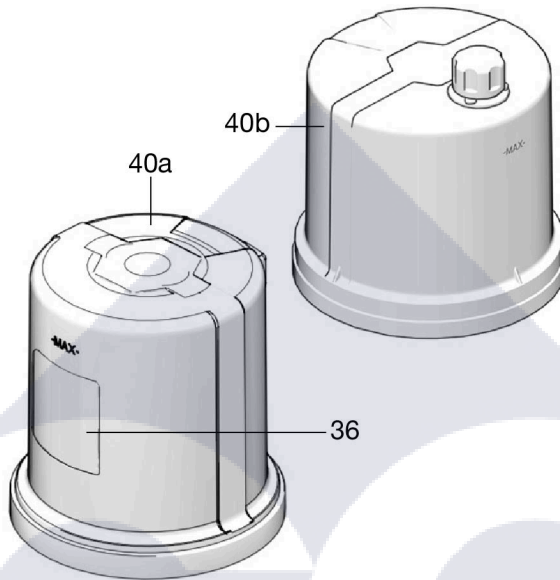

- ① Torque to 14 in-lb (1.58 N•m)
- ② Torque to 30 in-lb (3.4 N•m)
- ③ Torque to 50 in-lb (5.6 N•m)

ti23608b

Parts - 4 Liter and Larger Models

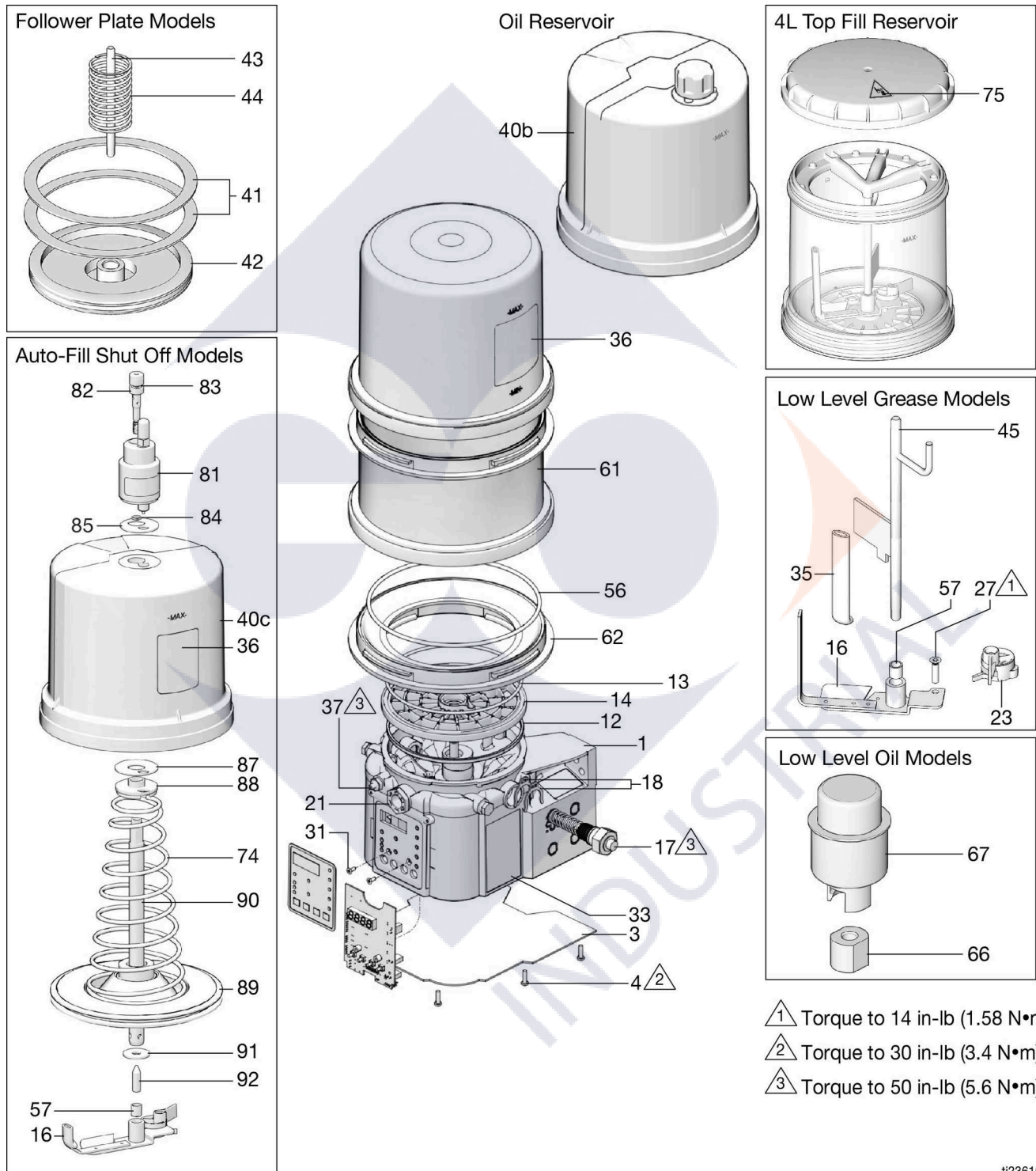

ti23610b

Parts

Ref	Part	Description	Qty
1		BASE, three pump housing	1
3	25V211	COVER, bottom, with seal	1
4	133767	SCREW, mach, torx pan hd, o-ring	9
12	127079	RECT-RING, included in Kit 571042, 571069, 571179	1
13	132524	O-RING, included in Kit 571042, 571044, 571045, 571069, 571179	1
14	278144	PLATE, ricer	1
15	120822	BEARING, ball	1
16		PADDLE, stirring, 2 Liter models and larger without follower plate, included in Kit 571046	1
		PADDLE, stirring, 4 Liter and Larger models without follower plate	1
		PADDLE, stirring, 2 Liter models and larger without follower plate, included in Kit 571047	1
		PADDLE, stirring, 4Liter models with follower plate	1
17		PUMP, element, included in Kit 571041	1
18	16F368	SPACER, stroke adjust, included in Kit 571041	2
21	278145	PLUG, pump, 3/4-16	2
23❖	279043	PADDLE, low level models	1
27	123025	SCREW, M6	1
30	24T872 or ‡* 25U992	BOARD, circuit, Pro	1
31	119228	SCREW, machine, flat head	2
33▲	16A579	LABEL, safety	1
34	16A578	LABEL, overlay	1
34		WIPER, stirring, models without follower plate, included in Kits 571044, 571046, and 571047	1
36		LABEL, brand	1
37	123741	FITTING, Zerk, grease (not included on models)	1
40a	24E984	RESERVOIR, 2 Liter, grease, included in Kit 571042, 571069	1

Ref	Part	Description	Qty
40b	16G021	RESERVOIR, 2 Liter, oil, included in Kit 571179	1
40a	577005	RESERVOIR, 4 Liter, grease, included in Kit 571183	1
40b	16G020	RESERVOIR, 4 Liter, oil, included in kit 571182	1
40c	17F484	RESERVOIR, 4 Liter, G3 AFSO	1
41	278139	SEAL, follower plate, 2 Liter models	1
	16F472	SEAL, follower plate, 4 Liter models	2
42		PLATE, follower	1
43		ROD, follower plate	1
44		SPRING, compression	1
45†	24D838	BAFFLE, low level, 2 Liter models	1
	24E246	BAFFLE, low level, 4 Liter models	1
	24F836	BAFFLE, low level, 8 Liter models	1
	24F923	BAFFLE, low level, 12 Liter models	1
	24F924	BAFFLE, low level, 16 Liter models	1
56	127144	SEAL, oval	1
57	117156	BEARING, sleeve	1
58▲	196548	LABEL	1
61	25C764	RESERVOIR, mid-section kit, with o-ring (see quantity by size / model below)	
		8 Liter models	1
		12 Liter models	2
		16 Liter	3
62	574002	ADAPTER, reservoir, 4Liter models and larger	1
66	126417	NUT, oil	
67	24N806	FLOAT, oil	
74		SPRING, plate, valve, reset	1
75	15H108	LABEL, safety, pinch 1	1
81		VALVE, AFSO	1

Ref	Part	Description	Qty
82		BOLT, mounting	1
83		PACKING, o-ring	1
84		PACKING, o-ring	1
85		SEAL, upper, reservoir	1
87		SEAL, lower, reservoir	1
88		SPACER, seal, base	1
89		PLATE, valve	1
90		TUBE, center fill	1
91		WASHER, plain	1
92		PIN, alignment	1
200	127783	CABLE, 15 ft (4.5 m), SOOW w/7 pos, 3 pin, 90 deg (See Wiring Diagram, page 15)	1
	127780	CABLE, 15 ft (4.5 m), SOOW w/7 pos, 5 pin, 90 deg, (See Wiring Diagram, page 16)	1
	127781	CABLE, 20 ft (6.1 m), SOOW, w/7 pos, 5 pin, 90 deg, (See Wiring Diagram, page 16)	1
	127782	CABLE, 30 ft (9.1m) SOOW, w/7 pos, 5 pin, 90 deg, (See Wiring Diagram, page 16)	1
	16U790	CABLE, DIN, bare, (See Wiring Diagram, page 15)	1
201	124300	CABLE, M12, 16.5 ft. (5 m), 4 wire, straight male to flying leads (See Wiring Diagram, page 15)	1
	124333	CABLE, M12, 6.5 ft. (5 m), 4 wire, straight male to female (See Wiring Diagram, page 15)	1
202	124301	CONNECTOR, straight, M12 female, 4 Pin	1
	124594	CONNECTOR, straight, M12 male, 4 Pin (see wiring diagram, page 16)	1
	124595	CONNECTOR, straight, M12 male, 5 Pin (see wiring diagram, page 16)	1

▲ Replacement Danger and Warning labels, tags and cards are available at no cost.

❖ Also order Ref 27, Part No. 123025

‡* For Pro Models Only - Also order Ref 31, Part No. 119228 and Ref 34, Part No. 16A578

† Also order Ref. 57, Part No. 117156 when ordering this part.

Installation and Repair Kits

Kit No.	Description	Manual Number
571026	KIT, output union, 3 pump	3A0523
571063	KIT, output union, 2 pump	
571028	KIT, return to reservoir NPT, includes pressure relief valve 16C807	3A0525
571071	KIT, return to reservoir BSPP, includes pressure relief valve 16C807	
571030	KIT, remote manual run, 12 volt DC	3A0528
571031	KIT, remote manual run, 24 volt DC	
571032	KIT, remote manual run, 12 volt DC, with cable	
571033	KIT, remote manual run, 24 volt DC with cable	
571036	KIT, cover with "G" label	NA
571041	KIT, pump element, includes Ref 17, 18, 33	3A0533
571042	KIT, repair, 2 liter reservoir, includes Ref 12, 13, 36, 40	3A0534
571069	KIT, repair, 2 liter reservoir, for models with follower plate, includes Ref 12, 13, 36, 40	
571044	KIT, replacement, paddle, 2 liter, for models without follower plate, includes Ref 13, 16, 35, 57	3A0535
571045	KIT, replacement, paddle, 2 liter, for models with follower plate, includes Ref 13, 16, 35, 40a, 42, 57	
571046	KIT, replacement, paddle, 4-16 liter, for models without follower plate, includes Ref 13, 16, 35, 57	
571047	KIT, replacement, paddle, 4 liter, for models with follower plate, includes Ref 13, 16, 35, 57	3A0522
571058	KIT, output adapter, NPT	
571070	KIT, output, adapter, BSPP	
571060	KIT, fill, zerk, leakproof	NA
571179	KIT, repair, reservoir oil, 2 liter models, includes Ref 12, 13, 36, 40b	3A0534
571182	KIT, repair, reservoir, oil 4 liter models, includes Ref 12, 13, 36, 40b, 56, 62	
571183	KIT, repair, reservoir, grease, 4 liter models, includes Ref 12, 13, 36, 40b, 56, 62	

Pressure Relief Valves

Important Information regarding Pressure Relief Valve 16C807.

Pressure Relief Valve 16C807 can only be used on the G3, G1, or G-Mini Pumps. It is not intended for use with any other products.

The pressure relief valve uses a pressure adjustment screw (a) to set the pressure release point. **It is not intended as a way to relieve pressure during normal operation,** but as a protective measure in the event there is an unintended pressure increase in the system. Do not use this pressure relief valve as a means of relieving pressure in day-to-day, normal cycle operation.

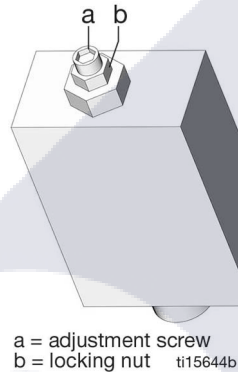

The pressure adjustment screw may require periodic adjustments. Whenever the valve is set/adjusted (after the set point is found) it is important to ensure that the valve is not bottomed out and there is at least 1/2 turn of adjustment remaining. This is determined by turning the screw (a) 1/2 turn and then back turning it out again.

NOTE: Turning adjustment screw (a) clockwise increases pressure.

NOTE: Each pressure relief valve requires banjo kit p/n 571058. (Except 16C807 because the banjo is already included in kit 571028.)

Part	Description	Qty
16C807◆	VALVE, pressure relief, 500-3500 psi (3.44 MPa, 34.4 bar - 24.1 MPa, 241 bar), Set pressure 3000 psi ± 10% (20.68 MPa, 206.8 bar ± 10%) Included in Kit 571028, 571071	1
563156	VALVE, pressure relief, 750 psi (5.17 MPa, 51.71 bar)	1
563157	VALVE, pressure relief, 1000 psi (6.89 MPa, 68.95 bar)	1
563158	VALVE, pressure relief, 1500 psi (10.34 MPa, 103.42 bar)	1
563159	VALVE, pressure relief, 2000 psi (13.78 MPa, 137.89 bar)	1
563160	VALVE, pressure relief, 2500 psi (17.23 MPa, 172.36 bar)	1
563161	VALVE, pressure relief, 3000 psi (20.68 MPa, 206.84 bar)	1

Fuses

Part	Description	Qty
571039	FUSE, 7.5 A for 12 volt DC	1
571040	FUSE, 4A for 24 volt DC	1

Reservoir Conversion Kits

Kit No.	Description	Manual Number
571155	KIT, reservoir conversion, 4 Liter	3A1260
571156	KIT, reservoir conversion, 8 Liter	
571157	KIT, reservoir conversion, 12 Liter	
571158	KIT, reservoir conversion, 16 Liter	
571299	KIT, reservoir conversion, 4L Top Fill	3A8295
571286	KIT, reservoir conversion, 4 Liter AFSO	3A5051
571287	KIT, reservoir conversion, 8 Liter AFSO	
571288	KIT, reservoir conversion, 12 Liter AFSO	
571289	KIT, reservoir conversion, 16 Liter AFSO	

Mount Pattern

(For correct mounting configuration, choose either Option 1 or Option 2). See P/N 126916 template.

Option 1

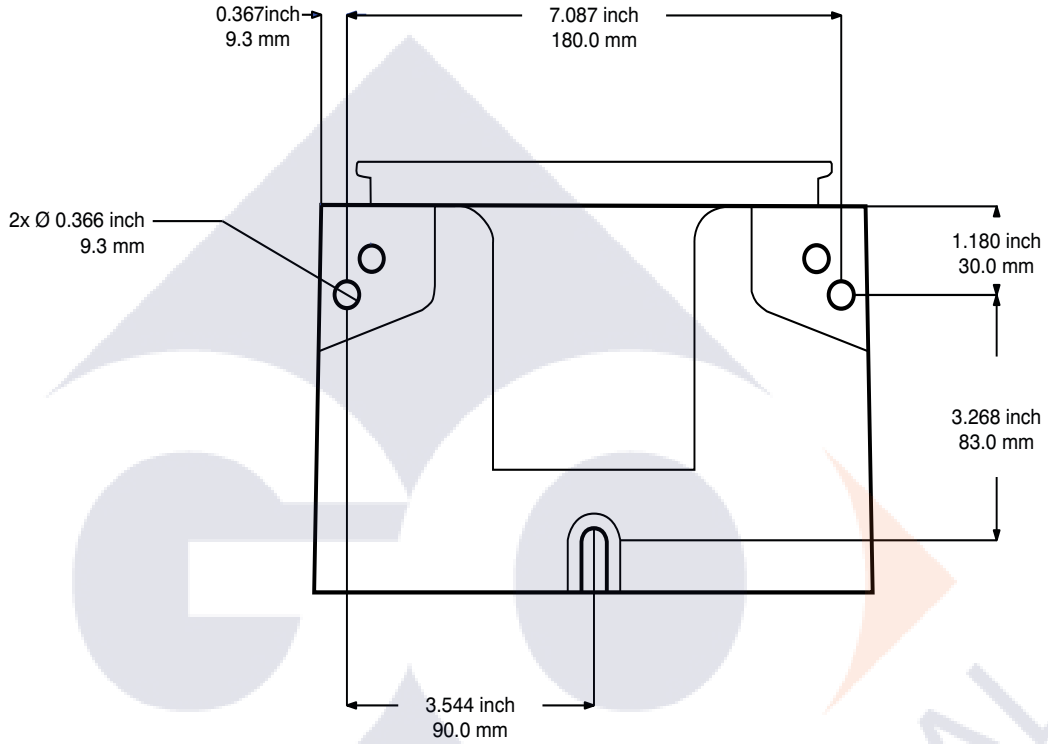

Option 2

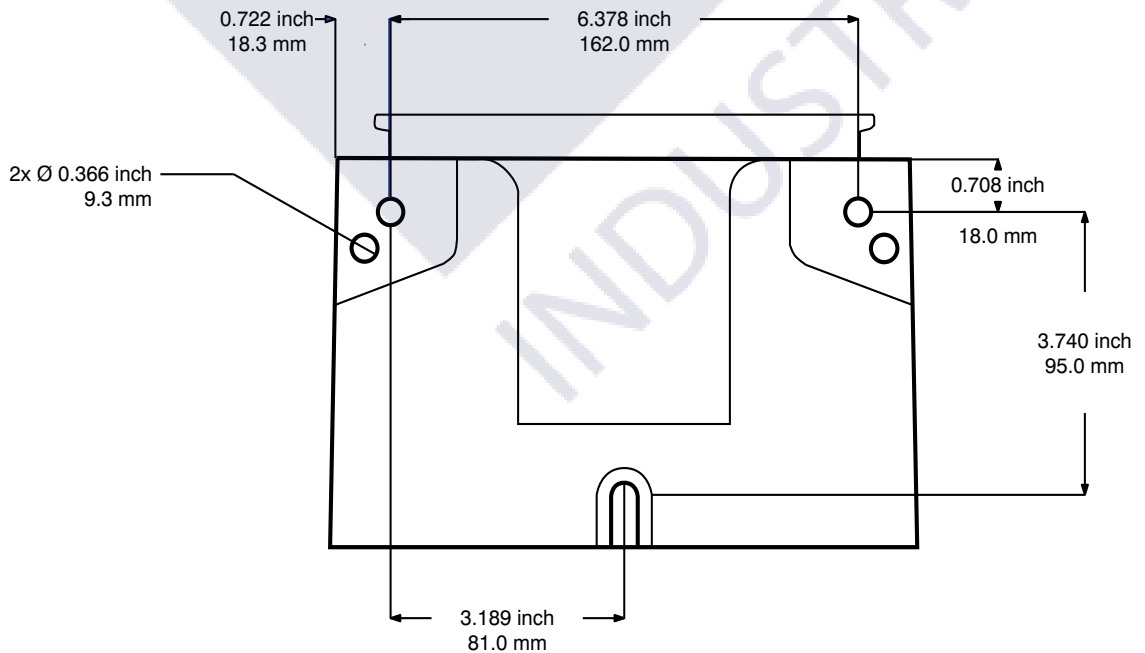

FIG. 37

Technical Specifications

G3 Pro Automatic Lubrication Pump		
	US	Metric
Pump output pressure	5100 psi	35.1 MPa, 351.6 bar
Fill inlet pressure	5000 psi	34.4 MPa, 344.7 bar
Power		
100 - 240 VAC	88-264 VAC; 0.8 A current, 90 VA Power, 47/63 Hz, Single phase, inrush/locked rotor, max 40 A (1ms)	
12 VDC	9-16 VDC; 5A current, 60 W, inrush/locked rotor 12 A	
24 VDC	18-30 VDC; 2.5 A current, 60 W, inrush/locked rotor 6 A	
Fluid		
Grease Models	Grease NLGI #000 - #2	
Oil Models	At least 40 cSt. oil	
Pumps		
	Up to 3	
Pump Output	0.12 in. ³ (2 cm ³) / minute per outlet - 2 spacers	
	0.18 in. ³ (3 cm ³) / minute per outlet - 1 spacer	
	0.25 in. ³ (4 cm ³) / minute per outlet - 0 spacers	
Pump Outlet	1/4 -18 NPSF. Mates with 1/4 - 18 NPT male fittings	
Reservoir Size	2, 4, 8, 12, 16 Liters	
IP Rating	IP69K	
Sensor Inputs	3 (any of pressure or cycle)	
	1 (machine count)	
Ambient Temperatures	-40°F to 158°F	-40°C to 70°C
Noise (dBa)		
Maximum sound pressure	<70dBa	
Materials of Construction		
Wetted Parts	nylon 6/6 (PA), amorphous polyamide, zinc plated steel, carbon steel, alloy steel, stainless steel, nitrile rubber (buna-N), bronze, nickel plated alnico, chemically lubricated acetal, aluminum, PTFE	
All trademarks or registered trademarks are the property of their respective owners.		

Pump Maximum Weight lb (kg)			
Model	With follower plate	Without follower plate	With auto-fill shut off
2L	12.4 (5.6)	11.4 (5.2)	N/A
4L	15.3 (6.9)	13.1 (5.9)	17.9 (8.1)
8L	16.8 (7.6)	14.6 (6.6)	19.7 (8.9)
12L	18.4 (8.3)	16.1 (7.3)	21.6 (9.8)
16L	19.9 (9.0)	17.6 (8.0)	23.4 (10.6)

California Proposition 65

CALIFORNIA RESIDENTS

 **WARNING:** Cancer and reproductive harm – www.P65warnings.ca.gov.



Graco Standard Warranty

Graco warrants all equipment referenced in this document which is manufactured by Graco and bearing its name to be free from defects in material and workmanship on the date of sale to the original purchaser for use. With the exception of any special, extended, or limited warranty published by Graco, Graco will, for a period of twelve months from the date of sale, repair or replace any part of the equipment determined by Graco to be defective. This warranty applies only when the equipment is installed, operated and maintained in accordance with Graco's written recommendations.

This warranty does not cover, and Graco shall not be liable for general wear and tear, or any malfunction, damage or wear caused by faulty installation, misapplication, abrasion, corrosion, inadequate or improper maintenance, negligence, accident, tampering, or substitution of non-Graco component parts. Nor shall Graco be liable for malfunction, damage or wear caused by the incompatibility of Graco equipment with structures, accessories, equipment or materials not supplied by Graco, or the improper design, manufacture, installation, operation or maintenance of structures, accessories, equipment or materials not supplied by Graco.

This warranty is conditioned upon the prepaid return of the equipment claimed to be defective to an authorized Graco distributor for verification of the claimed defect. If the claimed defect is verified, Graco will repair or replace free of charge any defective parts. The equipment will be returned to the original purchaser transportation prepaid. If inspection of the equipment does not disclose any defect in material or workmanship, repairs will be made at a reasonable charge, which charges may include the costs of parts, labor, and transportation.

THIS WARRANTY IS EXCLUSIVE, AND IS IN LIEU OF ANY OTHER WARRANTIES, EXPRESS OR IMPLIED, INCLUDING BUT NOT LIMITED TO WARRANTY OF MERCHANTABILITY OR WARRANTY OF FITNESS FOR A PARTICULAR PURPOSE.

Graco's sole obligation and buyer's sole remedy for any breach of warranty shall be as set forth above. The buyer agrees that no other remedy (including, but not limited to, incidental or consequential damages for lost profits, lost sales, injury to person or property, or any other incidental or consequential loss) shall be available. Any action for breach of warranty must be brought within two (2) years of the date of sale.

GRACO MAKES NO WARRANTY, AND DISCLAIMS ALL IMPLIED WARRANTIES OF MERCHANTABILITY AND FITNESS FOR A PARTICULAR PURPOSE, IN CONNECTION WITH ACCESSORIES, EQUIPMENT, MATERIALS OR COMPONENTS SOLD BUT NOT MANUFACTURED BY GRACO. These items sold, but not manufactured by Graco (such as electric motors, switches, hose, etc.), are subject to the warranty, if any, of their manufacturer. Graco will provide purchaser with reasonable assistance in making any claim for breach of these warranties.

In no event will Graco be liable for indirect, incidental, special or consequential damages resulting from Graco supplying equipment hereunder, or the furnishing, performance, or use of any products or other goods sold hereto, whether due to a breach of contract, breach of warranty, the negligence of Graco, or otherwise.

FOR GRACO CANADA CUSTOMERS

The Parties acknowledge that they have required that the present document, as well as all documents, notices and legal proceedings entered into, given or instituted pursuant hereto or relating directly or indirectly hereto, be drawn up in English. Les parties reconnaissent avoir convenu que la rédaction du présente document sera en Anglais, ainsi que tous documents, avis et procédures judiciaires exécutés, donnés ou intentés, à la suite de ou en rapport, directement ou indirectement, avec les procédures concernées.

Graco Information

For the latest information about Graco products, visit www.graco.com.

For patent information, see www.graco.com/patents.

TO PLACE AN ORDER, contact your Graco distributor or call to identify the nearest distributor.

Phone: 612-623-6928 **or Toll Free:** 1-800-533-9655, **Fax:** 612-378-3590

All written and visual data contained in this document reflects the latest product information available at the time of publication. Graco reserves the right to make changes at any time without notice.

Original instructions. This manual contains English. MM 332298

Graco Headquarters: Minneapolis

International Offices: Belgium, China, Japan, Korea

GRACO INC. AND SUBSIDIARIES • P.O. BOX 1441 • MINNEAPOLIS MN 55440-1441 • USA
Copyright 2013, Graco Inc. All Graco manufacturing locations are registered to ISO 9001.

www.graco.com

Revision L, May 2023