

G3 Pump Element Replacement Kit

3A0533D

ENG

Instructions for adding/replacing a Pump Element used in G3 pump. For professional use only.

Part No.: 571041



Important Safety Instructions

Read all warnings and instructions in this manual and the G3 Pump instruction manual included with your unit. Save these instructions.

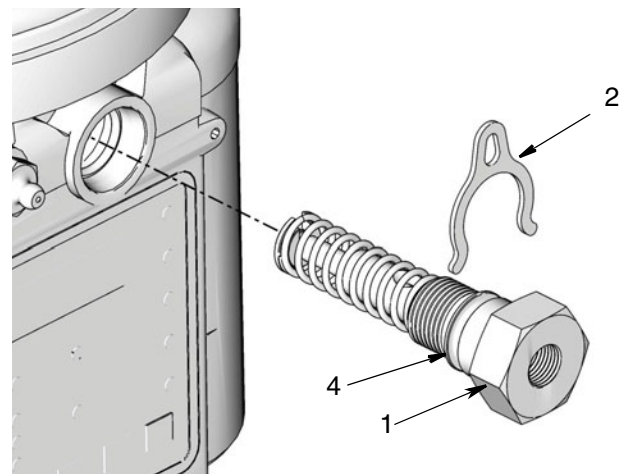



Kit Parts 571041

Ref.	Description	Qty
1	PUMP, element	1
2	SPACER, stroke adjust	2
3	LABEL, safety (not shown)	1
4	O-RING	1

Instructions

Pressure Relief

					
SKIN INJECTION HAZARD					
High-pressure fluid from dispense device, hose leaks, or ruptured components will pierce skin. This may look like just a cut, but it is a serious injury that can result in amputation. Get immediate surgical treatment.					
Follow Pressure Relief Procedure in this manual, when you stop dispensing and before cleaning, checking, or servicing equipment.					

Relieve pressure in system by using two wrenches working in opposite directions on pump element and pump element fitting to **only** loosen fitting.

NOTE: When loosening pump element fitting, do NOT loosen **pump element**. Loosening pump element will change the output volume.

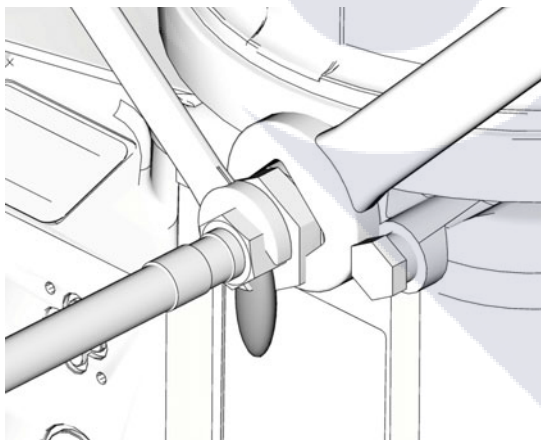

FIG. 1

Disassembly

The following instructions are for removing a pump element currently installed in the G3 Pump.

Reference numbers used in these instructions correspond to parts included in Kit and are provided on page 1. Parts identified with an alpha character are user provided or already installed components.



1. Disconnect power source.
2. Relieve pressure following Pressure Relief Procedure provided.
3. Disconnect anything installed to pump element such as pressure relief valves, output union, or other fittings.
4. Use a wrench to loosen pump element (1) and completely remove pump element and spacers (2) from G3 housing.

Make sure spring (a), retainer (b) and piston (c) are removed with pump element (FIG. 2).

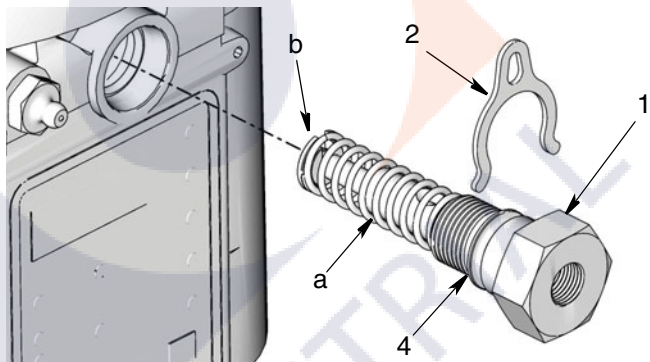

FIG. 2

5. Discard these parts. They are not required for installation of the new pump element.

Installation

1. Examine new pump element (1) . Make sure spring (a), retainer (b), o-ring (4) and piston are installed (FIG. 2).
2. Install stroke adjust spacers (2) (or no stroke adjust spacers) as required for correct volume output.
 - Discard old spacers you removed in Step 4. Only use new, Graco supplied spacers included in the kit to control output volume.
3. Slide pump element into G3 housing. Be careful not to cross thread the pump element during installation.

4. Tighten pump element by hand and then torque to 50 in. lbs (5.6 N•m) (FIG. 3).

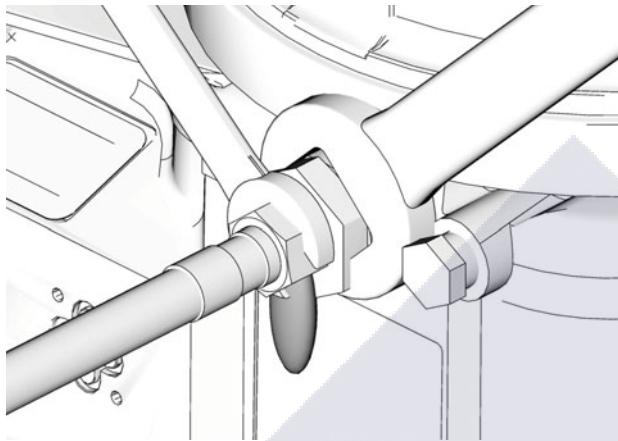

FIG. 3

Adjusting Output Volume

NOTE:

- It may be necessary to repeat the outlet volume setup procedure after the pump is operating to re-adjust the volume of dispensed grease.
- The amount of dispensed volume can vary depending on external conditions such as lubricant temperature and back pressure from downstream connections. Use the volume adjustments provided in Table 1 as a starting point and adjust as necessary to ensure desired lubrication dispense.

1. Use a wrench to turn pump element counter-clockwise to loosen.
2. If needed, remove or insert spacers to achieve required pump output volume.
 - Pump volume control is set using either no (0) spacers, 1 or 2 spacers (FIG. 4).
 - Do not use more than 2 spacers on any pump element.

Table 1: Output Volume

No. Spacers	Output Volume / Minute	
	cubic inches	cubic cm
0	0.247	4.0
1	0.182	3.0
2	0.117	2.0

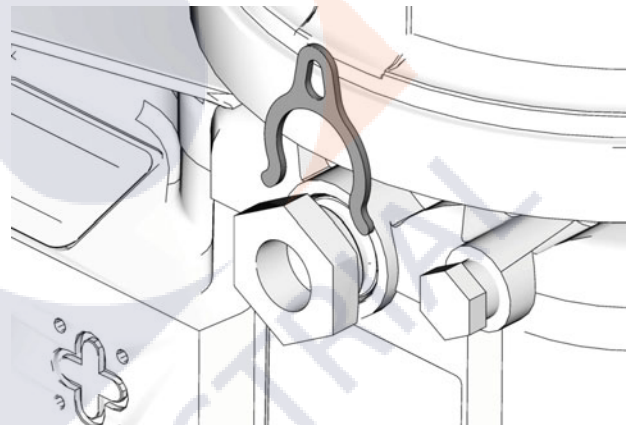

FIG. 4



*All written and visual data contained in this document reflects the latest product information available at the time of publication.
Graco reserves the right to make changes at any time without notice.*

Original instructions. This manual contains English. MM 3A0533

Graco Headquarters: Minneapolis

International Offices: Belgium, China, Japan, Korea

GRACO INC. P.O. BOX 1441 MINNEAPOLIS, MN 55440-1441

Copyright 2010, Graco Inc. is registered to ISO 9001

www.graco.com

6/2010, Revised 1/2011