



BBP™ 72 DOUBLE SIDED PRINTER
USER'S MANUAL

Edition: 9/2009 - Part No. 9008872

Copyright

This documentation as well as translation hereof are property of the manufacturer.

The replication, conversion, duplication or divulgement of the whole manual or parts of it for other intentions than its original intended purpose demand the previous written authorization by the manufacturer.

Trademark

Centronics® is a registered trademark of the Data Computer Corporation.

Microsoft® is a registered trademark of the Microsoft Corporation.

Windows 2000®, 2003®, XP® are registered trademarks of the Microsoft Corporation.

TrueType™ is a registered trademark of Apple Computer, Inc.

Editor

Regarding questions or comments please contact Brady.

Topicality

Due to the constant further development of our products discrepancies between documentation and product can occur.

Please check www.bradyid.com (US) or www.bradyeurope.com (Europe) for the latest update.

Terms and conditions

Deliveries and performances are effected under the General conditions of sale of Brady.

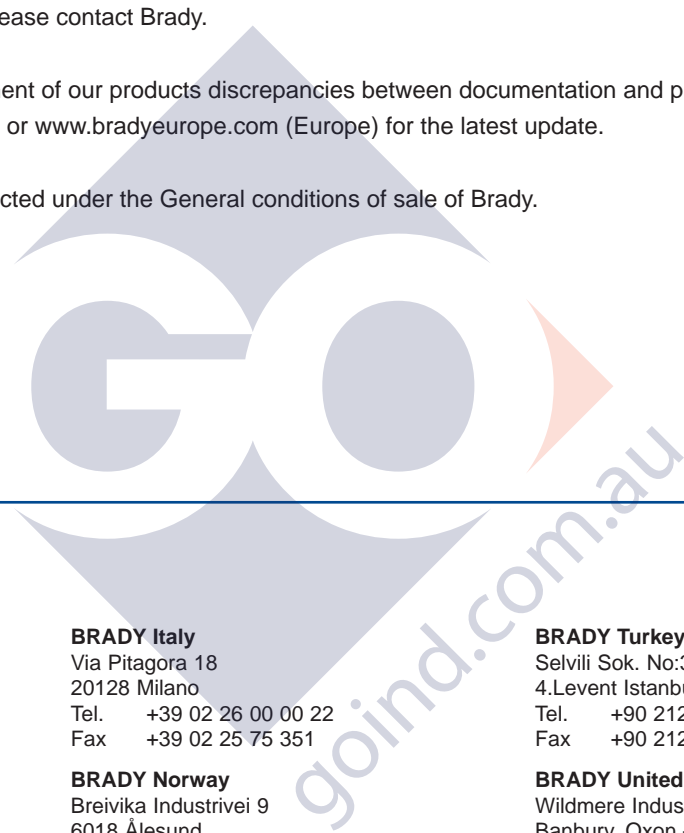

BRADY Belgium

Industriepark C/3
Lindestraat 20
9240 Zele
Tel. +32 (0) 52 45 78 11
Fax +32 (0) 52 45 78 12

BRADY Denmark

Svendborgvej 39 B
DK - 5260 Odense S
Tel. +45 66 14 44 00
Fax +45 66 14 44 50

BRADY France

Parc EURO CIT
45, avenue de l'Europe
59436 Roncq Cedex
Tel. +33 (0) 3 20 01 08 70
Fax +33 (0) 3 20 01 08 76

BRADY Germany

Büchenhöfe 2
63329 Egelsbach
Tel. +49 (0) 6103 7598 660
Fax +49 (0) 6103 7598 670

BRADY Hungary

Puskás Tivadar u. 4.
H-2040 Budaörs
Tel. +36 20 42 85 25
Fax +36 20 42 85 26

BRADY Italy

Via Pitagora 18
20128 Milano
Tel. +39 02 26 00 00 22
Fax +39 02 25 75 351

BRADY Norway

Breivika Industrivei 9
6018 Ålesund
Tel. +47 70 19 10 30
Fax +47 70 19 05 67

Brady Slovakia

Na Pántoch 18
831 06 Bratislava
Tel. +421 2 3300 4800
Fax +421 2 3300 4801

BRADY Spain

Carretera de Barcelona, 88
Esc B Entresuelo 9C
08302 Mataro
Tel. +34 900 902 993
Fax +34 900 902 994

Brady Sweden

Karins väg 5
194 54 Upplands Väsby
Tel. +46 (0) 8 590 057 30
Fax +46 (0) 8 590 818 68

BRADY Turkey

Selvili Sok. No:3/4
4.Levent Istanbul 34330
Tel. +90 212 264 02 20
Fax +90 212 270 83 19

BRADY United Kingdom

Wildmere Industrial Estate
Banbury, Oxon – OX16 3JU
Tel. +44 (0) 1295 228 200
Fax +44 (0) 1295 228 100

BRADY WORLDWIDE

Australia.....612-8717-6300
Brazil.....55-11-3686-4720
Canada.....1-800-263-6179
China (Beijing).....86-10-6788-7799
China (Shanghai).....86-21-6886-3666
China (Wuxi).....86-510-528-2222
Hong Kong.....852-2359-3149
Japan.....81-45-461-3600
Korea.....82-31-451-6600
Latin America.....1-414-540-5560
Malaysia.....60-4-646-2700
Mexico.....525-399-6963
New Zealand.....61-2-8717-2200
Philippines.....63-2-658-2077
Singapore.....65-6477-7261
Taiwan.....886-2-2657-6108
Thailand.....66-2-793-9200
U.S.A.1-800-537-8791

1	Introduction	4
1.1	Instructions	4
1.2	Intended Use	4
1.3	Safety Instructions	4
1.4	Environment	5
2	Installation	6
2.1	Device Overview	6
2.2	Unpacking and Setting-up the Printer	8
2.3	Connecting the Device	8
2.3.1	Connecting to the Power Supply	8
2.3.2	Connecting to a Computer or Computer Network	8
2.4	Switching on the Device	8
3	Control Panel	9
3.1	Structure of the Control Panel	9
3.2	Symbol Displays	9
3.3	Printer States	10
3.4	Key Functions	11
4	Loading Material	12
4.1	Loading Media from Roll	12
4.1.1	Positioning the Media Roll on the Roll Retainer	12
4.1.2	Inserting a Media Strip into the Print Mechanics	13
4.1.3	Setting the Material Sensor	14
4.2	Loading Transfer Ribbon	15
4.3	Setting the Feed Path of the Transfer Ribbon	16
4.4	Setting the Head Locking Systems	16
5	Printing Operation	17
5.1	Printhead Protection	17
5.2	Directions for Double-Sided Printing	17
5.2.1	Designing the Print Image	17
5.2.2	Identical Images on Both Sides	17
5.2.3	Backfeed	17
5.2.4	Synchronization in Cut Mode	17
6	Cleaning	18
6.1	Cleaning Information	18
6.2	Cleaning the Print Rollers	18
6.3	Cleaning the Printheads	18
7	Fault Correction	19
7.1	Types of Errors	19
7.2	Problem Solution	19
7.3	Error Messages and Fault Correction	20
8	Media	22
8.1	Media Dimensions	22
8.2	Device Dimensions	23
8.3	Reflex Mark Dimensions	24
8.4	Cut-out Mark Dimensions	25
9	Licences	26
10	Index	27

1.1 Instructions

Important information and instructions in this documentation are designated as follows:



Danger!

Draws your attention to an exceptionally grave, impending danger to your health or life.



Warning!

Indicates a hazardous situation that could lead to injuries or material damage.



Attention!

Draws attention to possible dangers, material damage or loss of quality.



Notice!

Gives you tips. They make a working sequence easier or draw attention to important working processes.



Environment!

Gives you tips on protecting the environment.



Handling instruction



Reference to section, position, illustration number or document.



Option (accessories, peripheral equipment, special fittings).

zeit

Information in the display.

1.2 Intended Use

- The device is manufactured in accordance with the current technological status and the recognized safety rules. However, danger to the life and limb of the user or third parties and/or damage to the device and other tangible assets can arise during use.
- The device may only be used for its intended purpose and if it is in perfect working order, and it must be used with regard to safety and dangers as stated in the operating manual.
- The device printer is intended exclusively for printing suitable materials that have been approved by the manufacturer. Any other use or use going beyond this shall be regarded as improper use. The manufacturer/supplier shall not be liable for damage resulting from unauthorized use; the user shall bear the risk alone.
- Usage for the intended purpose also includes complying with the operating manual, including the manufacturer's maintenance recommendations and specifications.



Notice!

The complete documentation is included in the scope of delivery on CD ROM, and can also currently be found in the Internet.

1.3 Safety Instructions

- The device is configured for voltages of 100 to 240 V AC. It only has to be plugged into a grounded socket.
- Only connect the device to other devices which have a protective low voltage.
- Switch off all affected devices (computer, printer, accessories) before connecting or disconnecting.
- The device may only be used in a dry environment, do not expose it to moisture (sprays of water, mists, etc.).
- Do not use the device in an explosive atmosphere.
- Do not use the device close to high-voltage power lines.
- If the device is operated with the cover open, ensure that people's clothing, hair, jewelry etc. do not come into contact with the exposed rotating parts.
- The device or parts of it, especially the printheads can become hot while printing. Do not touch during operation, and allow to cool down before changing material and before disassembly.

- Risk of crushing when closing the cover. Touch the cover at the outside only. Do not reach into the swivel range of the cover.
- Perform only those actions described in this operating manual.
Work going beyond this may only be performed by trained personnel or service technicians.
- Unauthorized interference with electronic modules or their software can cause malfunctions.
- Other unauthorized work on or modifications to the device can also endanger operational safety.
- Always have service work done in a qualified workshop, where the personnel have the technical knowledge and tools required to do the necessary work.
- There are various warning stickers on the device. They draw your attention to dangers.
Warning stickers must therefore not be removed, as then you and other people cannot be aware of dangers and may be injured.
- The maximum sound pressure level LpA is less than 70 dB(A).

**Danger!****Danger to life and limb from power supply.**

- ▶ Do not open the device casing.

1.4 Environment

Obsolete devices contain valuable recyclable materials that should be sent for recycling.

- ▶ Send to suitable collection points, separately from residual waste.

The modular construction of the printer enables it to be easily disassembled into its component parts.

- ▶ Send the parts for recycling.



The electronic circuit board of the device is equipped with a lithium battery.

- ▶ Take old batteries to collection boxes in shops or public waste disposal centers.

2.1 Device Overview

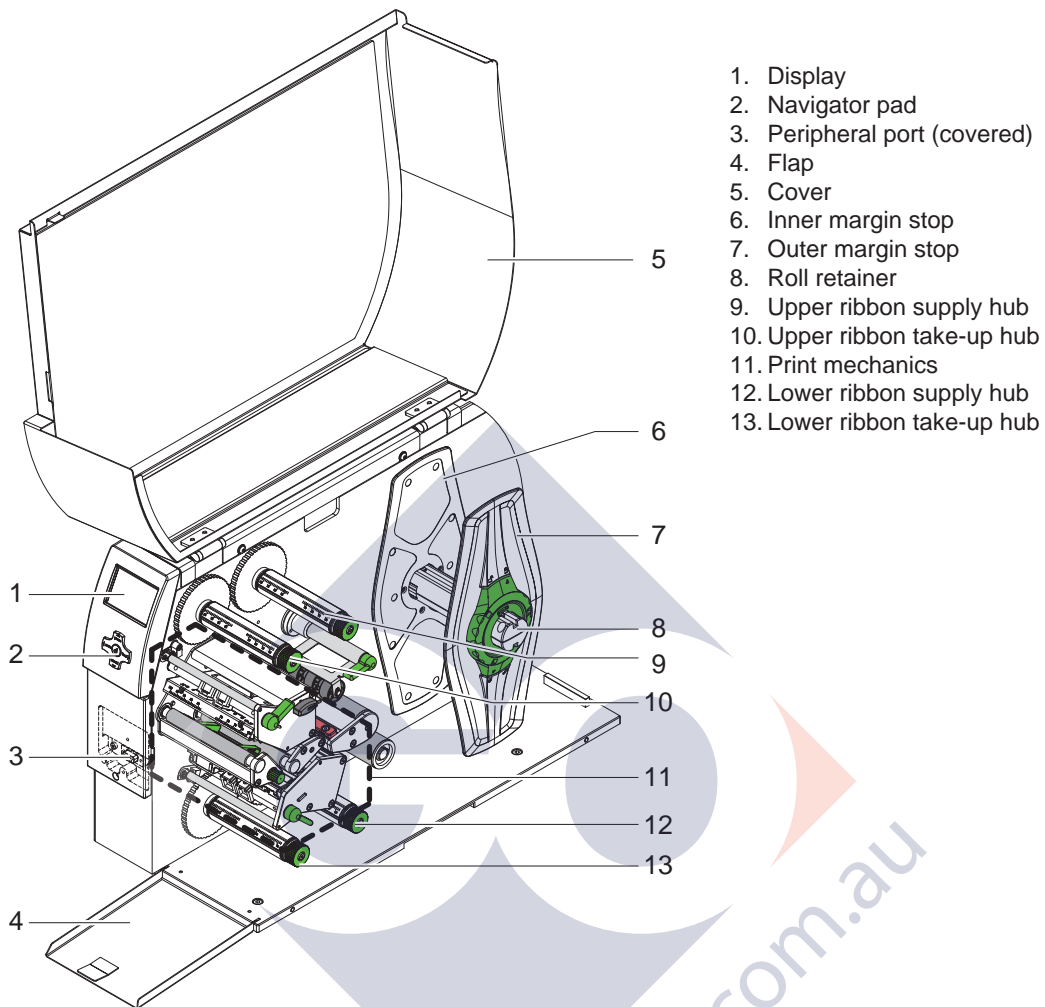

Fig. 1 Overview

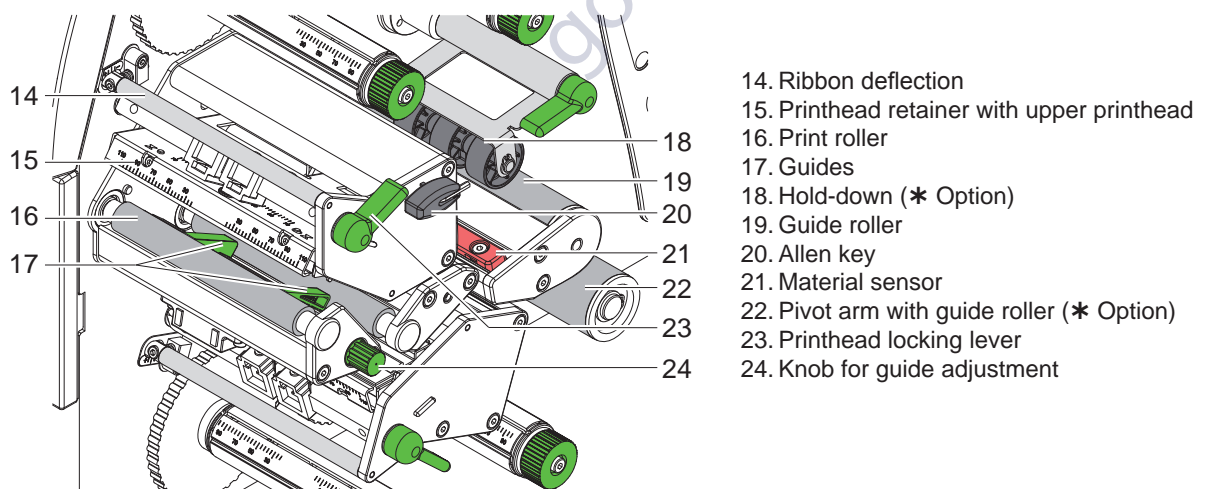

Fig. 2 Print mechanics - upper print unit

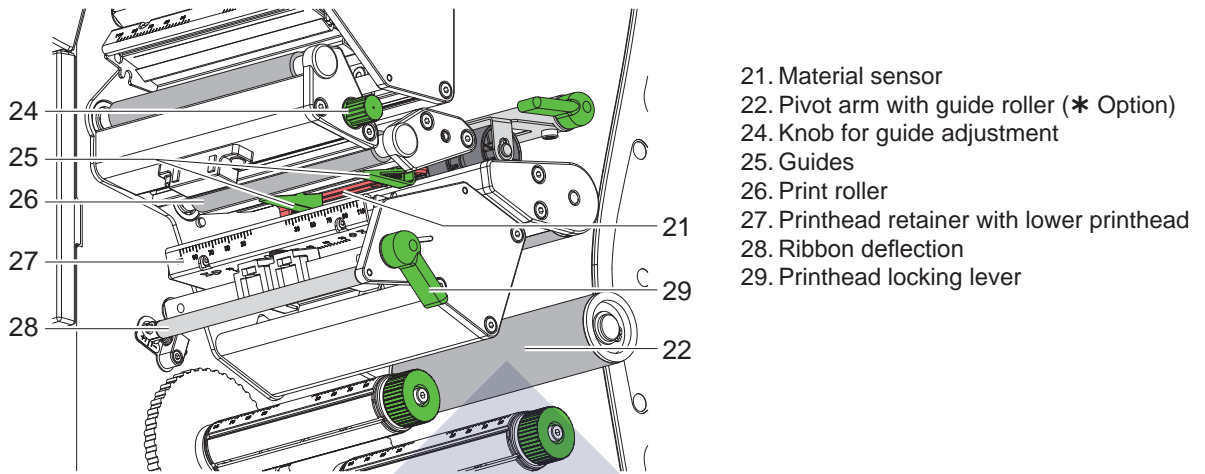

Fig. 3 Print mechanics - lower print unit

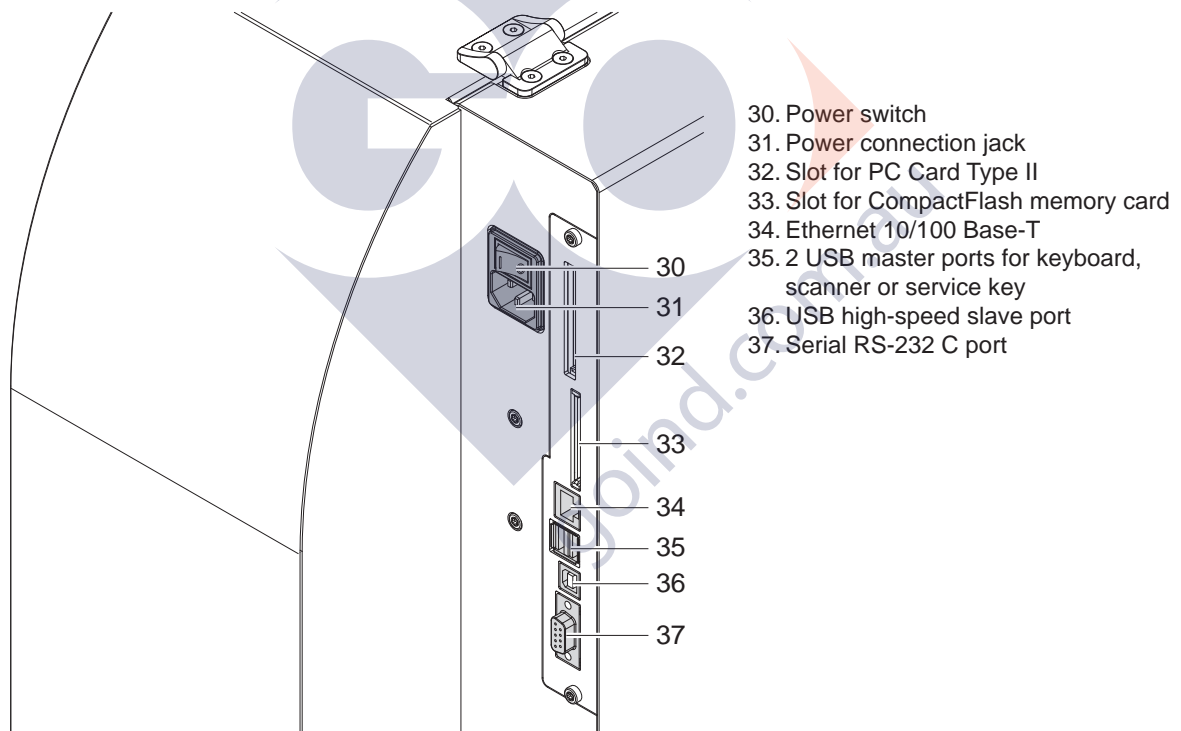

Fig. 4 Connections

2.2 Unpacking and Setting-up the Printer

- ▶ Lift the transfer printer out of the box via the straps.
- ▶ Check transfer printer for damage which may have occurred during transport.
- ▶ Set up printer on a level surface.
- ▶ Remove foam transportation safeguards near the printhead.
- ▶ Check delivery for completeness.

Contents of delivery:

- Transfer printer
- Power cable
- Documentation
- Documentation on CD-ROM

Notice!



Please keep the original packaging in case the printer must be returned.

Attention!



The device and printing materials will be damaged by moisture and wetness.

- ▶ Set up transfer printers only in dry locations protected from splash water.

2.3 Connecting the Device

The standard available interfaces and connectors are shown in figure 4.

2.3.1 Connecting to the Power Supply

The printer is equipped with a wide area power unit. The device can be operated with a supply voltage of 230 V~/50 Hz or 115 V~/60 Hz without adjustment.

1. Check that the device is switched off.
2. Plug the power cable into the power connection socket (31).
3. Plug the power cable into a grounded socket.

2.3.2 Connecting to a Computer or Computer Network

Attention!



Inadequate or no grounding can cause malfunctions during operations.

Ensure that all computers and cables connected to the transfer printer are grounded.

- ▶ Connect the transfer printer to a computer or network by a suitable cable.

For details of the configuration of the individual interfaces ▷ Configuration Manual.

2.4 Switching on the Device

When all connections have been made:

- ▶ Switch the printer on at the power switch (30).
The printer performs a system test, and then shows the system status *ready* in the display.

If an error occurs during the system test, the symbol  and type of error are displayed.

3.1 Structure of the Control Panel

The user can control the operation of the printer with the control panel, for example:

- Issuing, interrupting, continuing and canceling print jobs,
- Setting printing parameters, e.g. heat level of the printhead, print speed, interface configuration, language and time of day (▷ Configuration Manual),
- Start the test functions (▷ Configuration Manual),
- Control stand-alone operation with a memory module (▷ Configuration Manual),
- Update the firmware (▷ Configuration Manual).

Many functions and settings can also be controlled by software applications or by direct programming with a computer using the printer's own commands. ▷ Programming Manual for details.

Settings made on the control panel make the basic settings of the transfer printer.

Notice!



It is advantageous, whenever possible, to make adaptations to various print jobs in the software.

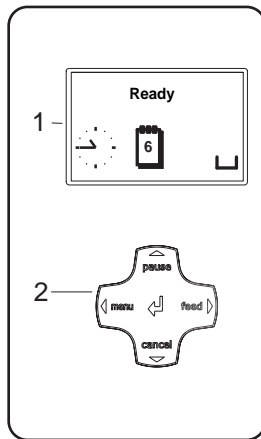

The control panel consists of a graphic display (1) and the navigator pad (2) with five integrated keys.

The graphic display indicates the current status of the printer and the print job, indicates faults and shows the printer settings in the menu.

Fig. 5 Control Panel

3.2 Symbol Displays

The symbols shown in the following table may appear in the status line of the display, depending on the printer configuration. They enable the current printer status to be seen quickly. For the configuration of the status line ▷ the Configuration Manual.

Symbol	Description	Symbol	Description	Symbol	Description
	Clock		Ethernet link status		User memory in the clock circuit
	Date sheet		Temperature of the printhead		Used memory
	Date/time digital		PPP funds		Input buffer
	Ribbon supply		Debug window for abc programs		Access to memory card
	Wi-Fi signal strength		Control of the lower display line is handed over to an abc program		Printer is receiving data

Table 1 Symbol displays

3.3 Printer States







State	Display	Description
Ready	Ready and configured symbol displays, such as time  and date 	The printer is in the ready state and can receive data.
Printing label	Printing label and the number of the printed label in the print job.	The printer is currently processing an active print job. Data can be transmitted for a new print job. The new print job will start when the previous one has finished.
Pause	Pause and the symbol 	The printing process has been interrupted by the operator.
Correctable error	 and the type of error and the number of labels still to be printed.	An error has occurred that can be rectified by the operator without interrupting the print job. The print job can be continued after the error has been rectified.
Irrecoverable error	 and the type of error and the number of labels still to be printed.	An error has occurred that cannot be rectified without interrupting the print job.
Critical error	 and the type of error	An error occurs during the system test. <ul style="list-style-type: none"> ▶ Switch the printer off and then on again at the power switch or ▶ Press cancel key. Call Service if the fault occurs persistently.
Power Save Mode	 and the key lighting is switched off	If the printer is not used for a lengthy period, it automatically switches to power save mode. <ul style="list-style-type: none"> ▶ To exit power save mode: Press any key on the navigator pad.

Table 2 Printer states

3.4 Key Functions

The key functions depend on the current printer state:

- Active functions: Labels and symbols on the navigator pad keys light up.
- Active functions light up white in print mode (e. g. menu or feed).
- Active functions light up orange in the offline menu (arrows, key 8).





Key	Display	State	Function	
menu	lights	Ready	Ready	To the offline menu
feed	lights	Ready	Ready	Feeds a blank label
pause	lights	Printing label	Printing label	* in cut mode only Interrupt print job, printer goes into "Pause" state
		Pause	Pause	* in cut mode only Continue the print job, printer goes into "Printing label" state
	flashes		Correctable error	Continue the print job after rectifying the error, printer goes into "Printing label" state ! Notice : The labels, which are printed by the lower printer but not yet printed by the upper printhead when the error occurs, cannot be repeated by the printer. So the amount of the printed label will be reduced within the print job.
cancel	lights	Printing label	Printing label	Short press → cancels the current print job Longer press → cancels the current print job and deletes all print jobs
		Pause	Pause	
	flashes		Correctable error	
			Irrecoverable error	
↩	lights		Error	Call Help - Concise information for rectifying the fault will be displayed

Table 3 Key functions in the print mode

Key	Menu	Parameter setting	
		Parameter choice	Numeric value
↑	Return from a submenu	-	Increase of the number at the cursor position
↓	Jump into a submenu	-	Decrease of the number at the cursor position
←	Menu option to the left	Sheets to the left	Cursor shift to the left
→	Menu option to the right	Sheets to the right	Cursor shift to the right
↩	Start of a selected menu option Pressing 2 s: Leaving the offline menu	Confirmation of the selected value Pressing 2 s: Abort without changing the value	

Table 4 Key functions in the offline menu

**Notice!**

For adjustments and simple installation work, use the accompanying Allen key located in the upper section of the print unit. No other tools are required for the work described here.

4.1 Loading Media from Roll

4.1.1 Positioning the Media Roll on the Roll Retainer

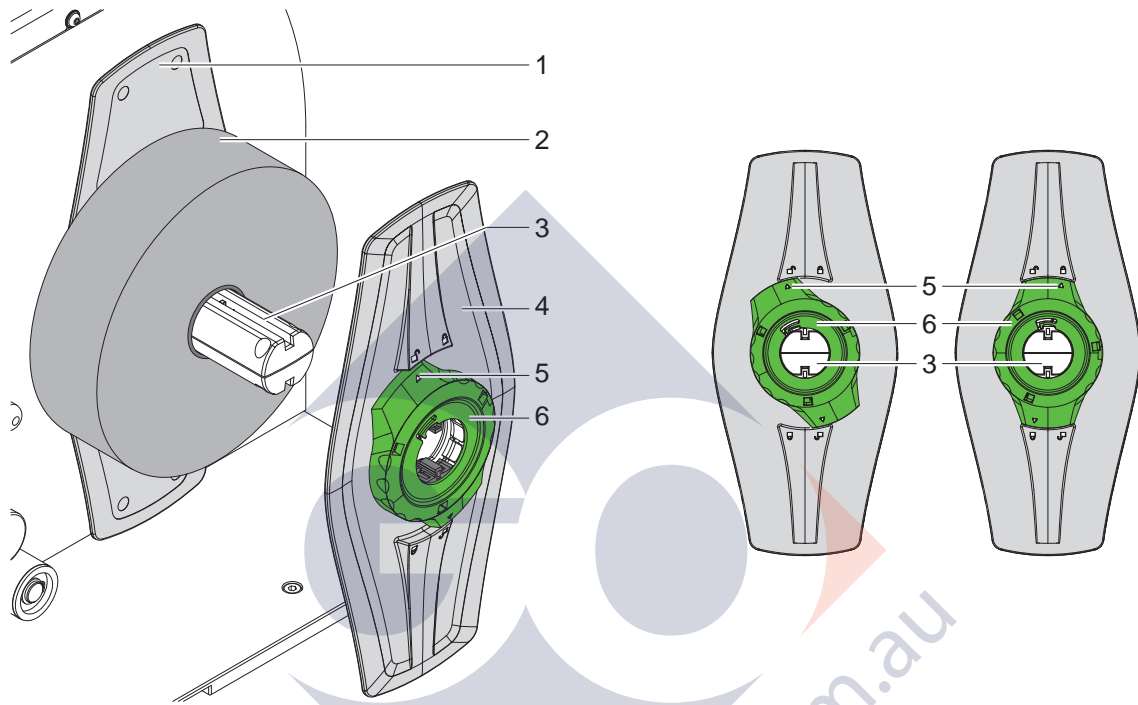



Fig. 6 Loading media from roll

Fig. 7 Margin stop (4) unfixed (left) and fixed (right)

1. Open cover.
2. Turn ring (6) counterclockwise, so that the arrow (5) points to the symbol , and thus release the margin stop (4).
3. Remove the margin stop (4) from the roll retainer (3).
4. Load label roll (2) on the roll retainer (3).
5. Re-mount the margin stop (4) onto the roll retainer (3). Push the margin stop (4) until both margin stops (1,4) touch the label roll (2) and a clear resistance is encountered.
6. Turn ring (6) clockwise, so that the arrow (5) points to the symbol , and thus fix the margin stop (4) on the roll retainer.

4.1.2 Inserting a Media Strip into the Print Mechanics

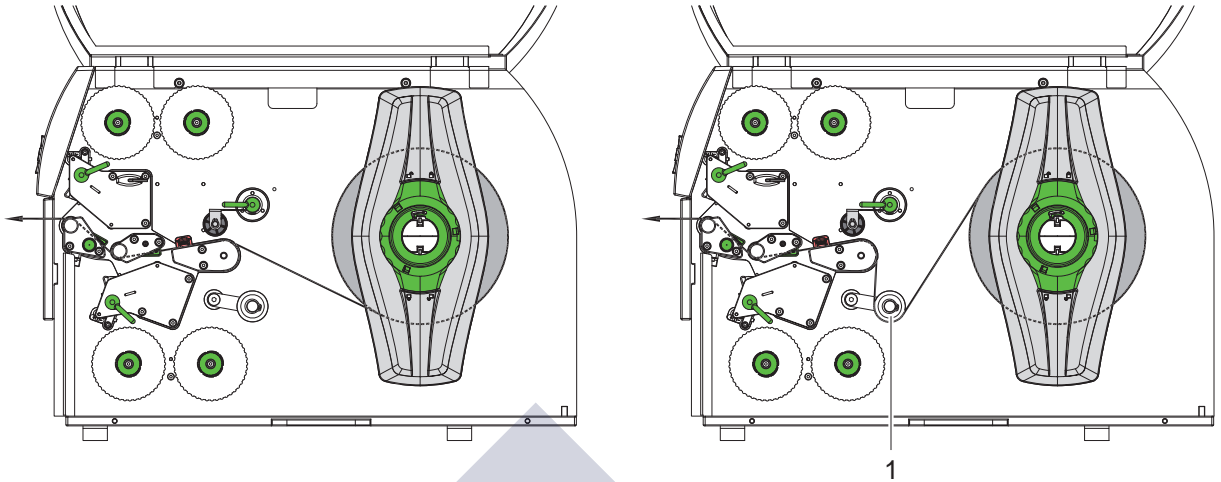

Fig. 8 Material feed path

1. Unroll a longer material strip of approx. 50 cm. Guide the media strip to the print mechanics as shown in figure 8. If the media is coming from above (figure 8 right side) guide it around the pivot arm (1).
2. Turn lever (2) counterclockwise and levers (7,8) clockwise to lift both printheads and the hold-down (9).
3. Move guides (5,6) apart with the knob (4) until the media can pass between them.
4. Guide media strip through the print mechanics as shown in figure 9 to the upper print roller (3) and place the strip between the guides (5,6).
5. Move guides against the edges of the material by turning the knob (4).
6. Fix the media by closing the upper printhead.
7. Turn the media roll against the feed direction to tighten the media.
8. Close the lower printhead.
9. Close the hold-down.

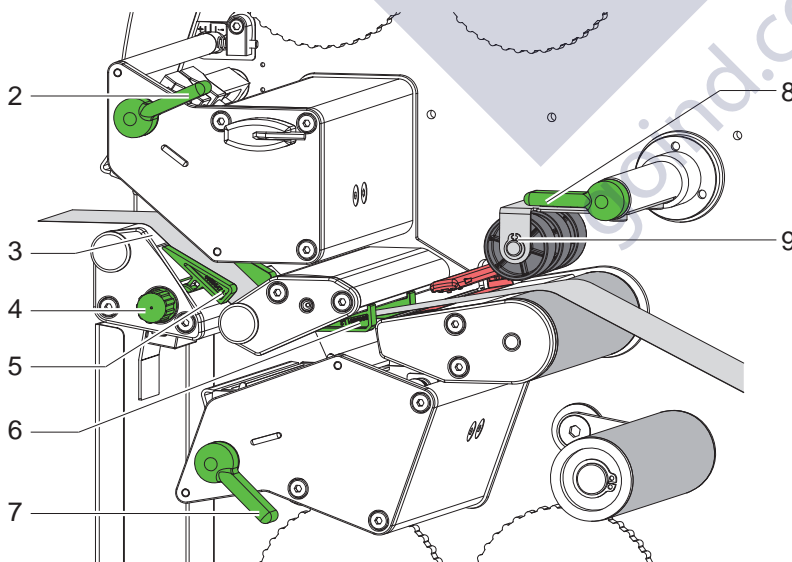

Fig. 9 Inserting a media strip into the print mechanics

4.1.3 Setting the Material Sensor

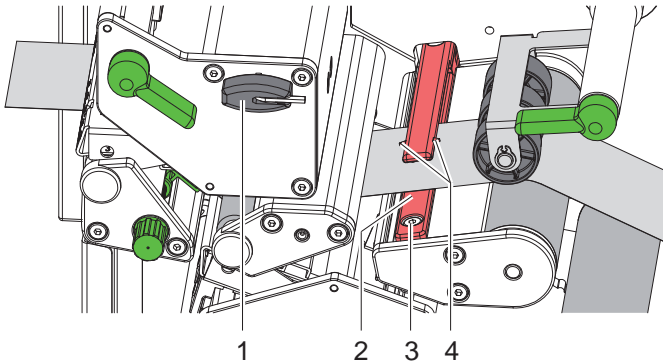

Fig. 10 Setting the material sensor

The material sensor (2) can be shifted perpendicular to the direction of media flow for adaptation to the media. The sensor unit is marked with indentation (4) on the label sensor retainer.

- ▶ Slightly loosen the screw (3) with Allen key (1).
- ▶ Position sensor by moving it in such a way that the sensor can detect a reflex or cut-out mark.
- ▶ Tighten the screw (3).



4.2 Loading Transfer Ribbon

Notice!

With direct thermal printing, do not load a transfer ribbon; if one has already been loaded, remove it.

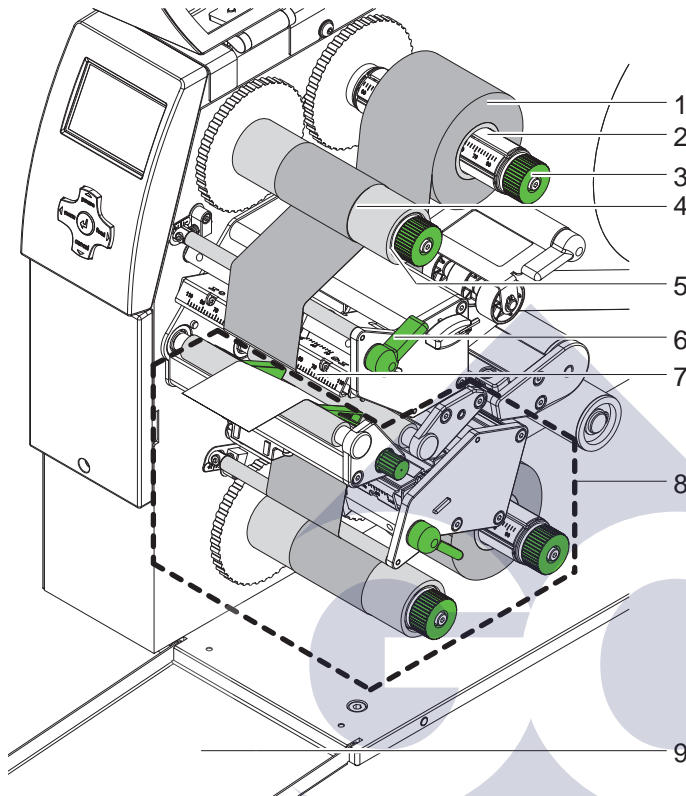

Fig. 11 Load transfer ribbon

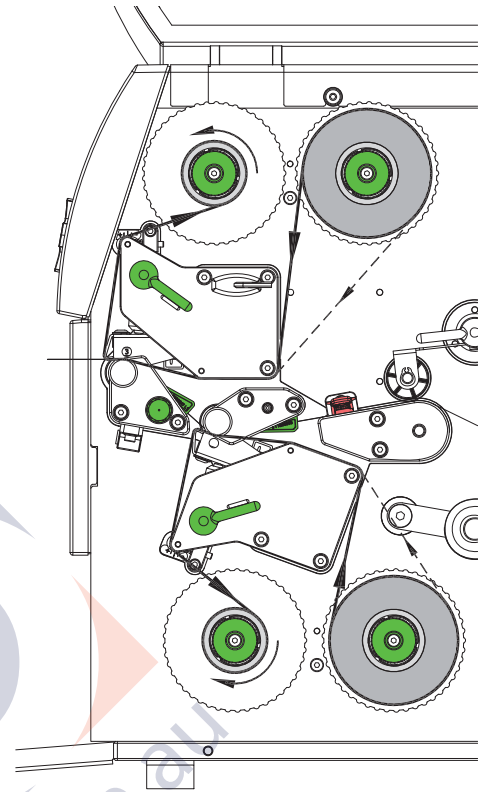

Fig. 12 Transfer ribbon feed path

1. Clean printheads before loading the transfer ribbon (▷ 6.3 on page 18).
2. Turn lever (6) counterclockwise to lift the upper printhead.
3. Slide transfer ribbon roll (1) onto the ribbon supply hub (3) so that the color coating of the ribbon faces downward when being unwound.
4. Position the ribbon roll (1) in such a way that both ends of the roll show identical scale values.
5. Hold transfer ribbon roll (1) firmly and turn knob (3) on ribbon supply hub counterclockwise until the transfer ribbon roll is secured.

**Notice!**

To rewind the transfer ribbon use a core with a width between the width of the supply roll and 115 mm.

6. Slide suitable transfer ribbon core (4) onto the transfer ribbon take-up hub (5). Position and secure it in the same way like the supply roll.
7. Guide transfer ribbon through the print unit as shown in Fig. 12.
8. Secure starting end of transfer ribbon to middle of the transfer ribbon core (4) with adhesive tape. When using cores which are wider than the transfer ribbon use the scale (7) at the printhead retainer to adjust the path of the ribbon. Ensure counterclockwise rotation direction of the transfer ribbon take-up hub.
9. Turn transfer ribbon take-up hub (5) counterclockwise to smooth out the feed path of the transfer ribbon.
10. Turn lever (6) clockwise to lock the printhead.
11. Open the flap (9) and load transfer ribbon to the lower print unit (8) in a similar way. All previous statements of direction apply contrariwise excepting the turning of the knobs.

4.3 Setting the Feed Path of the Transfer Ribbon

Transfer ribbon wrinkling can lead to print image errors. Transfer ribbon deflection can be adjusted so as to prevent wrinkles.



Notice!
The adjustment is best carried out during printing.

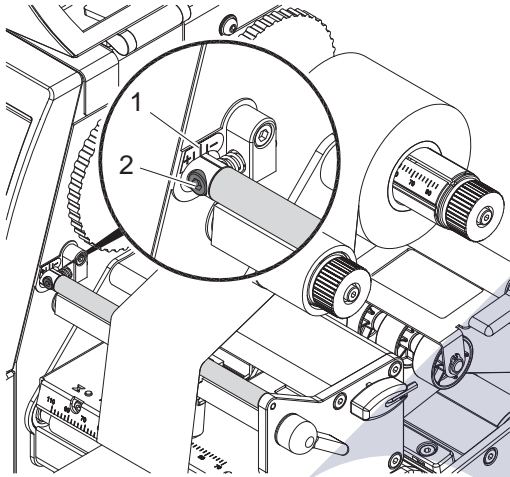

Fig. 13 Setting the upper ribbon feed path

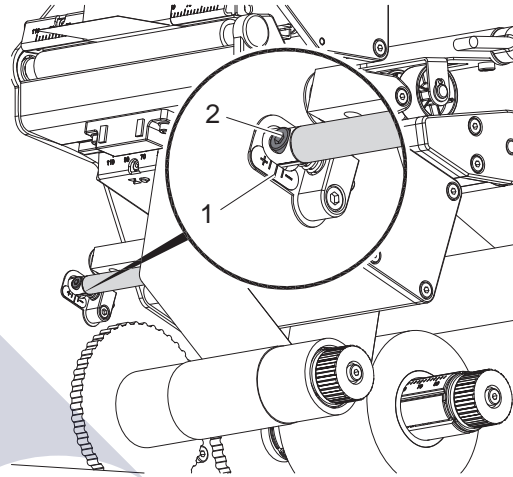

Fig. 14 Setting the lower ribbon feed path

1. Read current setting on the scale (1) and record if necessary.
2. Turn screw (2) with Allen key and observe the behavior of the ribbon.
In the + direction, the inner edge of the ribbon is tightened, and the outer edge is tightened in the - direction.

4.4 Setting the Head Locking Systems

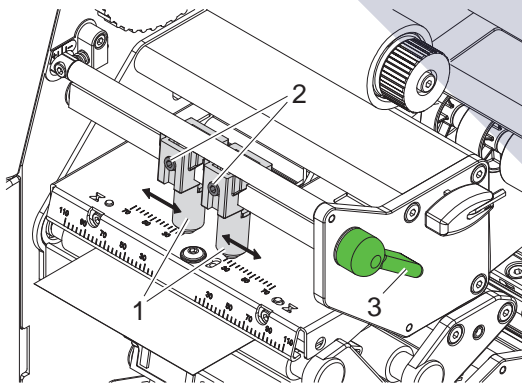

Fig. 15 Setting the upper head locking system

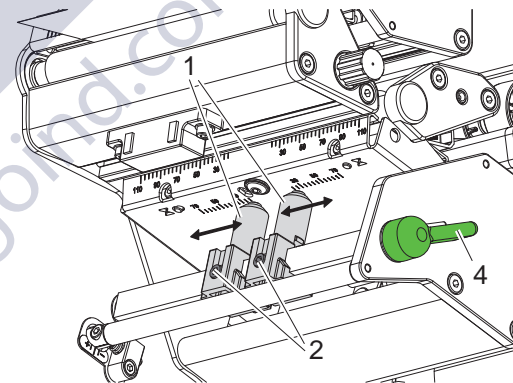

Fig. 16 Setting the lower head locking system

The printheads are pushed on via two plungers (1). In the basic setting the plungers are set in the middle of the printhead retainer. This setting can be used for the most applications.

If the print density decreases in the outer areas when using very large media, the plungers can be displaced :

1. Turn lever (3) clockwise and the lever (4) counterclockwise to lock the printheads.
2. Loosen threaded pins (2) at the plungers (1) with Allen key.
3. Displace plungers symmetrically as necessary maximal to the scale value 70.
4. Tighten the threaded pins (2).

5.1 Printhead Protection



Attention!

Printhead damage caused by improper handling!

- ▶ Do not touch the heating elements of the printheads with the fingers or sharp objects.
- ▶ Ensure that the material is clean.
- ▶ Ensure that the material surfaces are smooth. Rough material act like emery paper and reduce the service life of the printhead.
- ▶ Print with the lowest possible printhead temperature.

5.2 Directions for Double-Sided Printing

The printer is ready for operation when all connections have been made and labels and, if applicable, the transfer ribbon have been loaded.

5.2.1 Designing the Print Image

- ▶ Define the double material width as label width.
- ▶ Place the information for one print side at x-coordinates between 0 and the material width.
- ▶ Place the information for the other side at x-coordinates between the single and the double material width.

Notice!

The assignment of the two print images to the upper or lower printhead is depending on the parameters for rotating (command **O R**) or mirroring (command **O M**) the print image.

▷ Programming Manual.

5.2.2 Identical Images on Both Sides

- ▶ Define the single material width as label width.
- ▶ Place the information.
- ▶ Activate in the printer driver menu **General > Print Settings > Advanced Setup > Options** the setting "**top side same as bottom**".

or

- ▶ For direct programming use the command **O B** ▷ Programming Manual.

5.2.3 Backfeed

Notice!

Feeding back the material to the lower printhead in the cut mode or between print jobs is not allowed.

To avoid the backfeed :

- ▶ Activate in the printer driver menu **General > Print Settings > Advanced Setup > Options** the settings "**ignore label position**" and "**Force optimized printing**".

or

- ▶ For direct programming use the command **O F** ▷ Programming Manual.

5.2.4 Synchronization in Cut Mode

To guarantee the correct length of the first label a cut prior print job is required :

- ▶ Activate in the printer driver menu **General > Print Settings > Advanced Setup** the setting "**cut before labels**".

or

- ▶ For direct programming use the command **C s** ▷ Programming Manual.

6.1 Cleaning Information



Danger!

Risk of death via electric shock!

- ▶ **Disconnect the printer from the power supply before performing any maintenance work.**

The transfer printer requires very little maintenance.

It is important to clean the thermal printheads regularly. This guarantees a consistently good printed image and plays a major part in preventing premature wear of the printhead.

Otherwise, the maintenance is limited to monthly cleaning of the device.



Attention!

The printer can be damaged by aggressive cleansers.

Do not use abrasive cleaners or solvents for cleaning the external surfaces or modules.

- ▶ Remove dust and paper fluff from the print area with a soft brush or vacuum cleaner.
- ▶ The cover of the printer can be cleaned with a standard cleanser.

6.2 Cleaning the Print Rollers

Accumulations of dirt on the print rollers may impair the media transport and the print quality.

- ▶ Lift the printheads.
- ▶ Remove media and transfer ribbon from the printer.
- ▶ Remove deposits with roller cleaner and a soft cloth.
- ▶ If the roller appears damaged, replace it ▶ Service Manual.

6.3 Cleaning the Printheads

Cleaning intervals:

direct thermal printing	- every media roll change
thermal transfer printing	- every ribbon roll change

Substances may accumulate on the printheads during printing and adversely affect printing, e.g. differences in contrast or vertical stripes.



Attention!

Printheads can be damaged!

Do not use sharp or hard objects to clean the printheads.

Do not touch protective glass layer of the printheads.



Attention!

Risk of injury from the hot printhead lines.

Ensure that the printheads have cooled down before starting cleaning.

- ▶ Lift the printheads.
- ▶ Remove media and transfer ribbon from the printer.
- ▶ Clean printhead surfaces with special cleaning pen or a cotton swab dipped in pure alcohol.
- ▶ Allow printheads to dry for 2–3 minutes before commissioning the printer.

7.1 Types of Errors

The diagnostic system indicates on the screen if an error has occurred. The printer is set into one of the three possible error states according to the type of error.



State	Display	Key	Remark
Correctable error		pause flashes cancel lights	▷ 3.4 on page 11
Irrecoverable error		cancel flashes	
Critical fault		-	

Table 5 Error states

Attention!

State "Correctable error" :

The labels, which are printed by the lower printer but not yet printed by the upper printhead when the error occurs, cannot be repeated by the printer. So the amount of the printed label will be reduced within the print job.

▶ If necessary print more labels in a new job.

If the print job contains counters, after pressing the pause key the print job would be resumed with erroneous counter values.

▶ Quit the print job with the cancel key.

▶ Start a new print job with adapted counter values.

7.2 Problem Solution

Problem	Cause	Remedy
Transfer ribbon creases	Transfer ribbon deflection not adjusted	Adjust the transfer ribbon deflection. ▷ 4.3 on page 16
	Transfer ribbon too wide	Use a transfer ribbon slightly wider than the width of label.
Print image has smears or voids	Printhead is dirty	Clean the printhead ▷ 6.3 on page 18
	Temperature too high	Decrease temperature via software.
	Unsuitable combination of labels and transfer ribbon	Use different type of ribbon.
Printer does not stop after transfer ribbon runs out	Thermal printing is chosen in the software	Change to thermal transfer printing.
Printer prints a sequence of characters instead of the label format	Printer is in ASCII dump mode	Cancel the ASCII dump mode.
Printer transports label media, but transfer ribbon does not move	Transfer ribbon incorrectly inserted.	Check and, if necessary, correct the transfer ribbon web and the orientation of the label side.
	Unsuitable combination of labels and transfer ribbon	Use different type of ribbon.
Vertical white lines in the print image	Printhead is dirty	Clean the printhead ▷ 6.3 on page 18
	Printhead is defective (failure of heat elements)	Change the printhead. ▷ Service Manual.
Print image is irregular, one side is lighter	Printhead is dirty	Clean the printhead ▷ 6.3 on page 18

Table 6 Problem solution

7.3 Error Messages and Fault Correction

Error message	Cause	Remedy
ADC malfunction	Hardware error	Switch the printer off and then on. If error recurs call service.
Barcode error	Invalid barcode content, e.g. alphanumeric characters in a numerical barcode	Correct the barcode content.
Barcode too big	The barcode is too big for the allocated area of the label	Reduce the size of the barcode or move it.
Battery low	Battery of the PC card is flat	Replace battery in the PC card.
Buffer overflow	The input buffer memory is full and the computer is still transmitting data.	Use data transmission via protocol (preferably RTS/CTS).
Card full	No more data can be stored on the memory card	Replace card.
Cutter blocked	Cutter cannot return into its home position and stays in an undefined position	Switch off the printer. Remove material. Switch on the printer. Restart print job. Change material
	No cutter function	Switch the printer off and then on. If error recurs call service.
Cutter jammed	The cutter is unable to cut the labels but is able to return into its home position	Press the cancel key. Change material.
Device not conn.	Programming addresses a non-existent device	Either connect this device or correct the programming.
File not found	Requested file is not on the card	Check the contents of the card.
Font not found	Error with the selected download font	Cancel current print job, change font.
FPGA malfunction	Hardware error	Switch the printer off and then on. If error recurs call service.
Head error	Hardware error	Switch the printer off and then on. If error recurs replace printhead.
Head open	Printhead not locked	Lock printhead.
Head too hot	Printhead is overheated	After pausing the print job will be continued automatically. If the fault recurs repeatedly, reduce the heat level or the print speed via software.
Invalid setup	Error in the configuration memory	Re-configure printer. If error recurs call service.
Memory overflow	Current print job contains too much information, e.g. selected font, large graphics	Cancel current print job. Reduce amount of data to be printed.
Name exists	Duplicate usage of field name in the direct programming	Correct programming
No DHCP server	The printer is configured for DHCP, but there is no DHCP server, or the DHCP server is not currently available.	Switch off DHCP in the configuration, and assign a fixed IP address. Please contact your network administrator.
No label found	The label format as set in the software does not correspond with the real label format	Cancel current print job. Change the label format set in the software. Restart print job.
	Printer is loaded with continuous paper, but the software is set on labels	Cancel current print job. Change the label format set in the software. Restart the print job.
No label size	The format size is not defined in the programming.	Check programming.
No Link	No network link	Check network cable and connector. Please contact your network administrator.
No record found	Refers to the optional memory card; database access error	Check programming and card contents.

Error message	Cause	Remedy
No SMTP server	The printer is configured for SMTP, but there is no SMTP server, or the SMTP server is not currently available.	Switch off SMTP in the configuration. Caution! Then a warning cannot be sent by e-mail (EAlert). Please contact your network administrator.
No Timeserver	Timeserver is selected in the configuration, but there is no Timeserver, or the Timeserver is not currently available.	Switch off Timeserver in the configuration. Please contact your network administrator.
Out of paper	Out of label roll	Load labels.
	Error in the paper feed	Check media feed.
Out of ribbon	Out of transfer ribbon	Insert new transfer ribbon.
	Transfer ribbon melted during printing	Cancel current print job. Change the heat level via software. Clean the printhead ▷ 6.3 on page 18 Load transfer ribbon Restart print job.
	The printer is loaded with thermal labels, but the software is set to transfer printing	Cancel current print job. Set software to direct thermal printing. Restart print job
Protocol error	Printer has received an unknown or invalid command from the computer.	Press the pause key to skip the command or press the cancel key to cancel the print job.
Read error	Read error when reading from the memory card	Check data of the card. Backup data, reformat card.
Remove ribbon	Transfer ribbon is loaded although the printer is set to direct thermal printing	for direct thermal printing remove ribbon
		for thermal transfer printing set the printer in the configuration or in the software to transfer printing
Structural err.	Error in the file list of the memory card, data access is uncertain.	Format memory card.
Unknown card	Card not formatted, Type of card not supported	Format card, use different type of card.
USB error Device stalled	A USB device has been detected, but it is not working.	Do not use the USB device.
USB error Too much current	The USB device consumes too much current.	Do not use the USB device.
USB error Unknown device	Failure to detect USB device	Do not use the USB device.
Voltage error	Hardware error	Switch the printer off and then on. If error recurs call service. It is shown which voltage has failed. Please note.
Write error	Hardware error	Repeat the write process, reformat card.
Write protected	PC card write protection is activated.	Deactivate the write protection.
Wrong revision	Error when updating the firmware. Firmware not compatible with the hardware version	Load the compatible firmware.

Table 7 Error Messages and Fault Correction

8.1 Media Dimensions

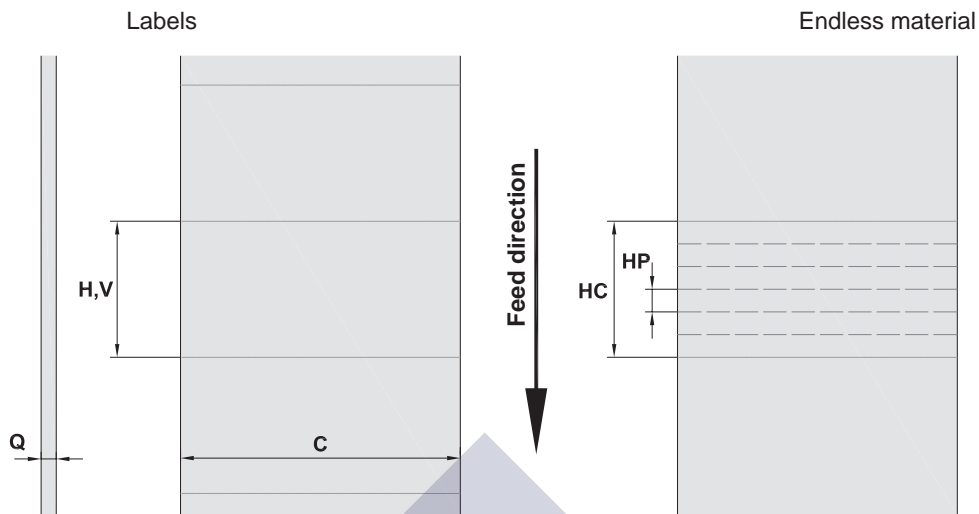

Fig. 17 Media dimensions

Dim.	Designation	Dim. in mm
C	Media width	3 - 110
Q	Media thickness	0,055 - 1,2
	Height of material passage	4,5
H	Print zone height	5 - 1000
V	Feed length	> 5
HC	Cut length	
	with cutter CU4	> 5
	with perforation cutter PCU4	> 5
HP	Perforation length	> 5
	• Note the bending stiffness ! Material must be flexible to follow the radius of the print roller !	

Table 8 Media dimensions

8.2 Device Dimensions

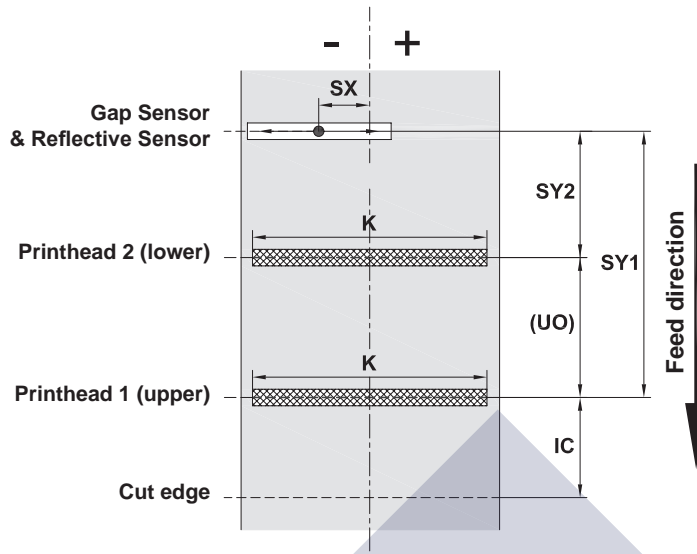

Fig. 18 Device dimensions

Dim.	Designation	Dim. in mm
IC	Distance printhead - cut edge with cutter CU4	18,8
	with perforation cutter PCU4	19,5
K	Print width	105,6
SX	Distance gap/reflective sensor - middle of media track i.e. permissible distance of reflex or cut-out marks from the middle of the material	-53 - ±0
SY1	Distance gap/reflective sensor - printhead 1 (upper)	132,4
SY2	Distance gap/reflective sensor - printhead 2 (lower)	66,2
UO	Distance printhead 2 (lower) - printhead 1 (upper)	66,2

Table 9 Device dimensions

8.3 Reflex Mark Dimensions

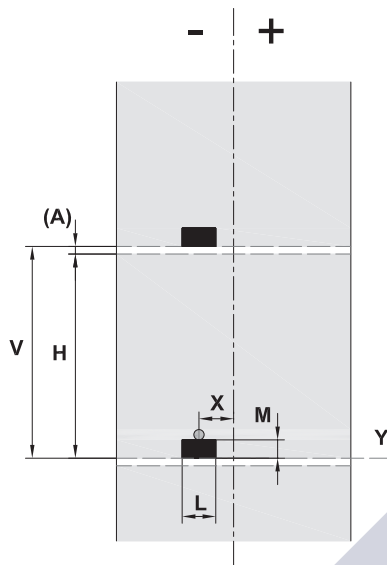

Fig. 19 Reflex mark dimensions

Dim.	Designation	Dim. in mm
H	Print zone height	5 - 1000
A	Print zone distance	> 2
V	Feed length	> 7
L	Width of reflex mark	> 5
M	Height of reflex mark	3 - 10
X	Distance mark - middle of media track = Distance gap/reflective sensor - middle of media track	-53 - ± 0
Y	Sensor recognized virtual print zone front edge	Front edge of mark
<ul style="list-style-type: none"> • Reflex marks must be on the back side of the material (liner). • Material sensor for reflex marks on the top side on request. • Specification is valid for black marks. • Recognition of colored marks may fail. ► Preliminary tests are needed. 		

Table 10 Reflex mark dimensions

8.4 Cut-out Mark Dimensions

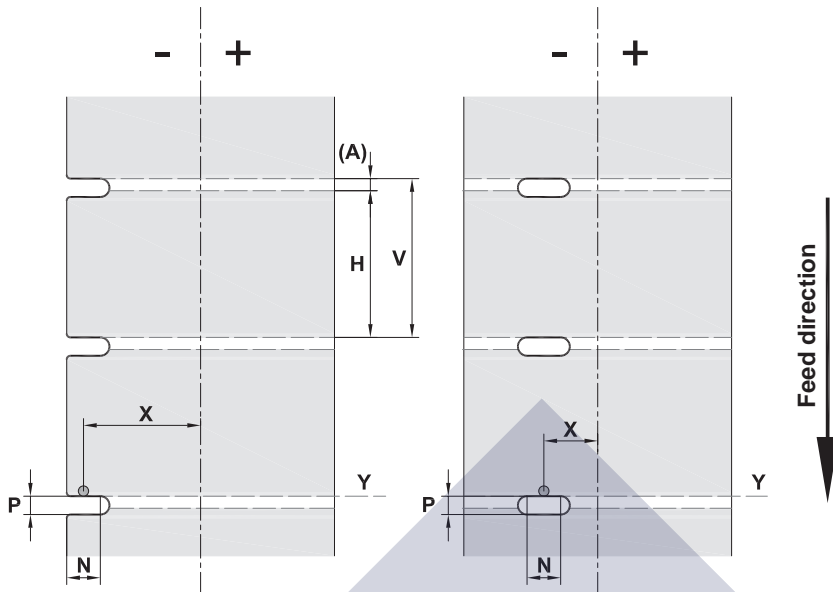
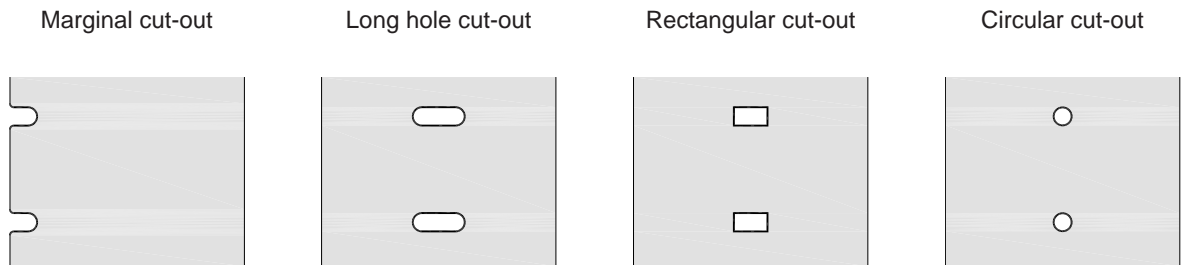

Fig. 20 Cut-out mark dimensions

Dim.	Designation	Dim. in mm
H	Print zone height	5 - 1000
A	Print zone distance	> 2
V	Feed length	> 7
N	Width of cut-out	> 5
P	Height of cut-out	2 - 10
X	Distance cut-out - middle of media track = Distance gap/reflective sensor - middle of media track	-53 - ±0
Y	Sensor recognized virtual print zone front edge with gap sensor recognition	Rear edge cut-out

Table 11 Cut-out mark dimensions



Not recommended !

Fig. 21 Samples for cut-out marks



Gesellschaft für Computer-
und Automations-
Bausteine mbH & Co KG
Wilhelm-Schickard-Str. 14
D-76131 Karlsruhe,
Germany

EU Declaration of Conformity

We declare herewith that as a result of the manner in which the machine designated below was designed, the type of construction and the machines which, as a result have been brought on to the general market comply with the relevant fundamental regulations of the EU Rules for Safety and Health. In the event of any alteration which has not been approved by us being made to any machine as designated below, this statement shall thereby be made invalid.

Device: **Transfer Printer** Type: **XD4M**

Applied EU Regulations and Norms:

- | | |
|--|--|
| <ul style="list-style-type: none"> • EC Machinery Regulations • Safety of Machinery | <p>98/37/EU
EN ISO 12100-1:2003
EN ISO 12100-2:2003</p> |
| <ul style="list-style-type: none"> • EC Voltage Regulations • Data and Office Machine Safety | <p>2006/95/EU
EN 60950-1:2006</p> |
| <ul style="list-style-type: none"> • EC Electromagnetic Compatibility Regulations • Threshold values for the interference of Data Machines • Immunity characteristics
Limits and methods of measurement • Limits for harmonic current emission • Limits of voltage fluctuation and flicker | <p>2004/108/EU
EN 55022:2006 - Class A
EN 55024:1998 +A1:2001 + A2:2003
EN 61000-3-2:2006
EN 61000-3-3:1995 + A1:2001 + A2:2005</p> |

Signed for, and on behalf of the Manufacturer :

cab Produkttechnik Sömmerda
Gesellschaft für Computer-
und Automationsbausteine mbH
99610 Sömmerda

Sömmerda, 29.05.09

Erwin Fascher
Managing Director

B		L	
Backfeed.....	17	Lithium battery	5
C		Loading media	12
Cleaning		Loading media from roll.....	12
printhead.....	18	Loading transfer ribbon.....	15
print roller.....	18	M	
Cleaning information.....	18	Material sensor	
Connecting	8	setting	13
Contents of delivery.....	8	N	
Control panel	9	Navigator pad	9
Correctable error	10	O	
Critical error	10	Offline menu	11
Cut-out marks	25	P	
Cut Mode.....	17	Pause	10
D		Power save mode.....	10
Designing the print image.....	17	Power supply	4
Device dimensions	23	Printer states	10
Device overview	6	Printhead	
E		cleaning	18
Environment	4, 5	damage.....	17
Errors		Printing label.....	10
correction	20	Print roller, cleaning.....	18
display.....	19	Problem solution.....	19
messages	20	R	
states	19	Ready	10
types	19	Reflex marks.....	24
EU Conformity Declaration.....	26	Ribbon deflection, setting	16
G		S	
Graphic display.....	9	Safety instructions	4
H		Service work.....	5
Head locking system, setting.....	16	Setting-up	8
Help calling.....	11	Supply voltage	8
Hold-down	6, 13	Switching on	8
I		Symbol displays.....	9
Identical images.....	17	U	
Important information.....	4	Unpacking.....	8
Intended use.....	4	V	
Irrecoverable error.....	10	Voltage.....	4
K		W	
Key		Warning stickers	5
cancel	11		
enter.....	11		
feed.....	11		
menu	11		
pause	11		
Key functions	11		
offline menu	11		
print mode.....	11		

This page is intentionally left blank.

