

DH230/GH™ 130/200/230/300 Hydraulic Sprayers

334558D

EN

For professional use only.

Not approved for use in explosive atmosphere or hazardous locations.

For portable airless spraying of architectural paints and coatings.

3300 psi (22.8 MPa, 228 bar) Maximum Working Pressure

See page 3 for model information, including maximum working pressure and approvals.



Important Safety Instructions

Read all warnings and instructions in this manual and in related manuals.

Be familiar with the controls and the proper usage of the equipment.

Save these instructions.

Related Manuals:

311861	GH130/200 Gun	334654	Pump
311254	DH230/GH230/300 Gun	310812	Electric Motor

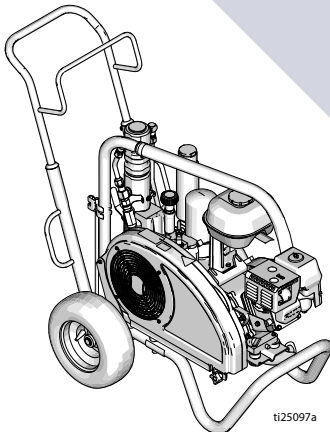

Standard Series

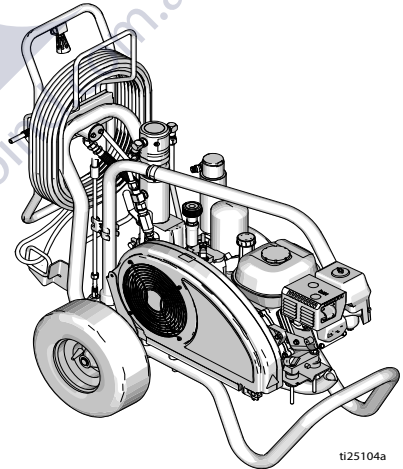

ProContractor Series

*Use only genuine Graco replacement parts.
The use of non-Graco replacement parts may void warranty.*



Table of Contents

Models	3
Electric Motor Kit Options	3
OEM Kits	3
Warnings	4
Component Identification	10
Grounding	13
Grounding Procedure for Internal Combustion Engine	13
Grounding Procedure for Electric Motor	13
Grounding of Pails	14
Pressure Relief Procedure	14
Setup	15
Change Engine or Motor	15
Complete Setup	16
Startup	18
Switch Tip™ and Guard Assembly	21
Spray	22
Clear Tip Clog	22
Hose Reel	23
Clean Up	24
Maintenance	26
Troubleshooting	27
Standard Series Pump	29
ProContractor Series Pump	30
GH™130/200/230/300 Standard Series Parts	33
DH230/GH™200/230/300 ProContractor Series Parts (OEM Kits)	45
Technical Data	61
GH™130 Standard Series	61
GH™200 Standard Series	62
GH™230 Standard Series	62
GH™300 Standard Series	63
GH™200 ProContractor Series	64
DH230/GH™230 ProContractor Series	65
GH™300 ProContractor Series	66
Graco Standard Warranty	68
Graco Information	69

Models

GH130				
Model:	Standard	120V Motor Kit (Non CSA)		
24W923	✓			
24W924	✓	✓		
DH230				
Model:	Standard	ProContractor		
17G591		✓		
GH200				
Model:	Standard	ProContractor	120V Motor Kit (Non CSA)	
24W925	✓			
24W926	✓		✓	
24W927		✓		
24W928		✓	✓	
GH230				
Model:	Standard	ProContractor	120V Motor Kit (Non CSA)	120V ETL/CSA/UL Motor Kit
24W929	✓			
24W930	✓		✓	
24W931	✓			✓
24W932		✓		
24W933		✓	✓	
24W934		✓		✓
GH300				
Model:	Standard	ProContractor		
24W935	✓			
24W936		✓		

Electric Motor Kit Options

Kit Number	Sprayer Model	Description
288474	GH130	120VAC, 60Hz, 20A, ETL/CSA/UL Approved
288473	GH130	120VAC, 60Hz, 15A
248950	GH200/DH230/GH230/GH300*	120VAC, 60Hz, 20A, ETL/CSA/UL Approved
248949	GH200/DH230/GH230/GH300*	120 VAC, 60Hz, 15A
24M668	GH200/DH230/GH230/GH300*	240VAC, 50Hz, 15A

*Performance is limited when using electric motor vs internal combustion engine

OEM Kits

Kit Number	OEM Model	Description
24W297	GH130 OEM	3300 psi (22.8 MPa, 228 bar) Maximum Working Pressure (psi)
24W298	GH200 OEM	3300 psi (22.8 MPa, 228 bar) Maximum Working Pressure (psi)
24W299	GH230/300 OEM	3330 psi (22.8 MPa, 228 bar) Maximum Working Pressure (psi)

Warnings

The following warnings are for the setup, use, grounding, maintenance, and repair of this equipment. The exclamation point symbol alerts you to a general warning and the hazard symbols refer to procedure-specific risks. When these symbols appear in the body of this manual or on warning labels, refer back to these Warnings. Product-specific hazard symbols and warnings not covered in this section may appear throughout the body of this manual where applicable.

WARNING



GROUNDING

This product must be grounded. In the event of an electrical short circuit, grounding reduces the risk of electric shock by providing an escape wire for the electric current. This product is equipped with a cord having a grounding wire with an appropriate grounding plug. The plug must be plugged into an outlet that is properly installed and grounded in accordance with all local codes and ordinances.

- Improper installation of the grounding plug is able to result in a risk of electric shock.
- When repair or replacement of the cord or plug is required, do not connect the grounding wire to either flat blade terminal.
- The wire with insulation having an outer surface that is green with or without yellow stripes is the grounding wire.
- Check with a qualified electrician or serviceman when the grounding instructions are not completely understood, or when in doubt as to whether the product is properly grounded.
- Do not modify the plug provided; if it does not fit the outlet, have the proper outlet installed by a qualified electrician.
- This product is for use on a nominal 120V or 230V circuit and has a grounding plug similar to the plugs illustrated in the figure below.

120V US



230V

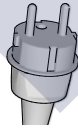

- Only connect the product to an outlet having the same configuration as the plug.
- Do not use an adapter with this product.
- Extension Cords:
 - Use only a 3-wire extension cord that has a grounding plug and a grounding receptacle that accepts the plug on the product.
 - Make sure your extension cord is not damaged. If an extension cord is necessary, use 12 AWG (2.5 mm²) minimum to carry the current that the product draws.
 - An undersized cord results in a drop in line voltage and loss of power and overheating.

Electric Motor Warnings

 **WARNING**
**FIRE AND EXPLOSION HAZARD**

Flammable fumes, such as solvent and paint fumes, in **work area** can ignite or explode. To help prevent fire and explosion:

- Do not spray flammable or combustible materials near an open flame or sources of ignition such as cigarettes, motors, and electrical equipment.
- Paint or solvent flowing through the equipment is able to result in static electricity. Static electricity creates a risk of fire or explosion in the presence of paint or solvent fumes. All parts of the spray system, including the pump, hose assembly, spray gun, and objects in and around the spray area shall be properly grounded to protect against static discharge and sparks. Use Graco conductive or grounded high-pressure airless paint sprayer hoses.
- Verify that all containers and collection systems are grounded to prevent static discharge. Do not use pail liners unless they are anti static or conductive.
- Connect to a grounded outlet and use grounded extensions cords. Do not use a 3-to-2 adapter.
- Do not use a paint or a solvent containing halogenated hydrocarbons.
- Do not spray flammable or combustible liquids in a confined area.
- Keep spray area well-ventilated. Keep a good supply of fresh air moving through the area.
- Sprayer generates sparks. Keep pump assembly in a well ventilated area at least 20 feet (6.1 m) from the spray area when spraying, flushing, cleaning, or servicing. Do not spray pump assembly.
- Do not smoke in the spray area or spray where sparks or flame is present.
- Do not operate light switches, engines, or similar spark producing products in the spray area.
- Keep area clean and free of paint or solvent containers, rags, and other flammable materials.
- Know the contents of the paints and solvents being sprayed. Read all Safety Data Sheets (SDS) and container labels provided with the paints and solvents. Follow the paint and solvents manufacturer's safety instructions.
- Fire extinguisher equipment shall be present and working.

Warnings

Internal Combustion Engine Warnings

WARNING



FIRE AND EXPLOSION HAZARD

Flammable fumes, such as solvent and paint fumes, in **work area** can ignite or explode. To help prevent fire and explosion:



- Use equipment only in well ventilated area.
- Do not fill fuel tank while engine is running or hot; shut off engine and let it cool. Fuel is flammable and can ignite or explode if spilled on hot surface.



- Eliminate all ignition sources; such as pilot lights, cigarettes, portable electric lamps, and plastic drop cloths (potential static arc).



- Keep work area free of debris, including solvent, rags and fuel.
- Do not plug or unplug power cords, or turn power or light switches on or off when flammable fumes are present.

- Ground all equipment in the work area. See **Grounding** instructions.

- Use only grounded hoses.

- Hold gun firmly to side of grounded pail when triggering into pail. Do not use pail liners unless they are anti static or conductive.

- **Stop operation immediately** if static sparking occurs or you feel a shock. Do not use equipment until you identify and correct the problem.

- Keep a working fire extinguisher in the work area.



CARBON MONOXIDE HAZARD

Exhaust contains poisonous carbon monoxide, which is colorless and odorless. Breathing carbon monoxide can cause death.

- Do not operate in an enclosed area.



BURN HAZARD

Equipment surfaces and fluid that is heated can become very hot during operation. To avoid severe burns:

- Do not touch hot fluid or equipment.

Electric Motor/Internal Combustion Engine Warnings

! WARNING**SKIN INJECTION HAZARD**

High-pressure spray is able to inject toxins into the body and cause serious bodily injury. In the event that injection occurs, **get immediate surgical treatment.**



- Do not aim the gun at, or spray any person or animal.
- Keep hands and other body parts away from the discharge. For example, do not try to stop leaks with any part of the body.



- Always use the nozzle tip guard. Do not spray without nozzle tip guard in place.
- Use Graco nozzle tips.



- Use caution when cleaning and changing nozzle tips. In the case where the nozzle tip clogs while spraying, follow the **Pressure Relief Procedure** for turning off the unit and relieving the pressure before removing the nozzle tip to clean.



- Equipment maintains pressure after power is shut off. Do not leave the equipment energized or under pressure while unattended. Follow the **Pressure Relief Procedure** when the equipment is unattended or not in use, and before servicing, cleaning, or removing parts.

- Check hoses and parts for signs of damage. Replace any damaged hoses or parts.

- This system is capable of producing 3300 psi (22.8 MPa, 228 bar). Use Graco replacement parts or accessories that are rated a minimum of 3300 psi (22.8 MPa, 228 bar).

- Always engage the trigger lock when not spraying. Verify the trigger lock is functioning properly.

- Verify that all connections are secure before operating the unit.

- Know how to stop the unit and bleed pressure quickly. Be thoroughly familiar with the controls.

WARNING



EQUIPMENT MISUSE HAZARD

Misuse can cause death or serious injury.

- Always wear appropriate gloves, eye protection, and a respirator or mask when painting.
- Do not operate or spray near children. Keep children away from equipment at all times.
- Do not overreach or stand on an unstable support. Keep effective footing and balance at all times.
- Stay alert and watch what you are doing.
- Do not operate the unit when fatigued or under the influence of drugs or alcohol.
- Do not kink or over-bend the hose.
- Do not expose the hose to temperatures or to pressures in excess of those specified by Graco.
- Do not use the hose as a strength member to pull or lift the equipment.
- Do not spray with a hose shorter than 25 feet.
- Do not alter or modify equipment. Alterations or modifications may void agency approvals and create safety hazards.
- Make sure all equipment is rated and approved for the environment in which you are using it.



PRESSURIZED ALUMINUM PARTS HAZARD

Use of fluids that are incompatible with aluminum in pressurized equipment can cause serious chemical reaction and equipment rupture. Failure to follow this warning can result in death, serious injury, or property damage.

- Do not use 1,1,1-trichloroethane, methylene chloride, other halogenated hydrocarbon solvents or fluids containing such solvents.
- Do not use chlorine bleach.
- Many other fluids may contain chemicals that can react with aluminum. Contact your material supplier for compatibility.



MOVING PARTS HAZARD

Moving parts can pinch, cut or amputate fingers and other body parts.

- Keep clear of moving parts.
- Do not operate equipment with protective guards or covers removed.
- Pressurized equipment can start without warning. Before checking, moving, or servicing equipment, follow the **Pressure Relief Procedure** and disconnect all power sources.



WARNING



ENTANGLEMENT HAZARD

Rotating parts can cause serious injury.

- Keep clear of moving parts.
- Do not operate equipment with protective guards or covers removed.
- Do not wear loose clothing, jewelry or long hair while operating equipment.
- Equipment can start without warning. Before checking, moving, or servicing equipment, follow the **Pressure Relief Procedure** and disconnect all power sources.



TOXIC FLUID OR FUMES HAZARD

Toxic fluids or fumes can cause serious injury or death if splashed in the eyes or on skin, inhaled, or swallowed.

- Read SDSs to know the specific hazards of the fluids you are using.
- Store hazardous fluid in approved containers, and dispose of it according to applicable guidelines.



RECOIL HAZARD

Gun may recoil when triggered. If you are not standing securely, you could fall and be seriously injured.



PERSONAL PROTECTIVE EQUIPMENT

Wear appropriate protective equipment when in the work area to help prevent serious injury, including eye injury, hearing loss, inhalation of toxic fumes, and burns. Protective equipment includes but is not limited to:

- Protective eye wear, and hearing protection.
- Respirators, protective clothing, and gloves as recommended by the fluid and solvent manufacturer.

CALIFORNIA PROPOSITION 65

The engine exhaust from this product contains a chemical known to the State of California to cause cancer, birth defects or other reproductive harm.

This product contains a chemical known to the State of California to cause cancer, birth defects or other reproductive harm. Wash hands after handling.

Component Identification

Component Identification

Standard Models (GH130, GH200, GH230, GH300)

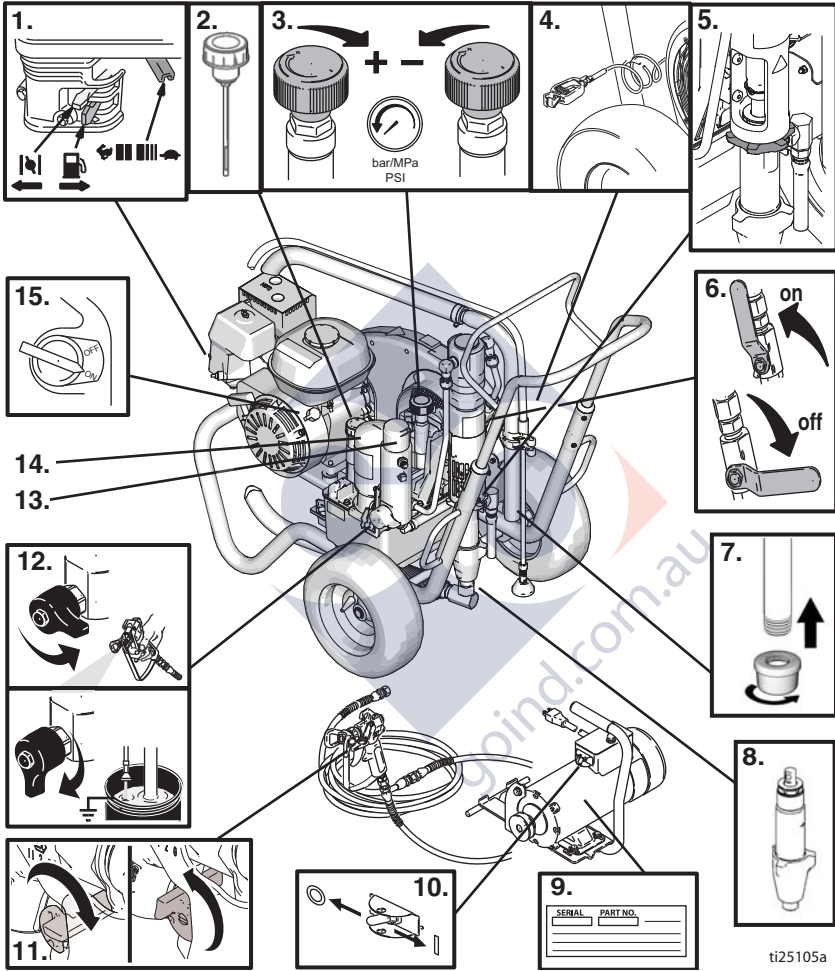

1	Engine Controls
2	Hydraulic Oil Cap / Dipstick
3	Pressure Control
4	Grounding Clamp
5	Threaded Pump Connection
6	Hydraulic Pump Valve
7	Inlet Strainer

8	Displacement Pump
9	Serial Number Tag (2 places)
10	Electric Motor On/Off Switch

Component Identification

ProContractor Models (GH200, GH230, GH300)

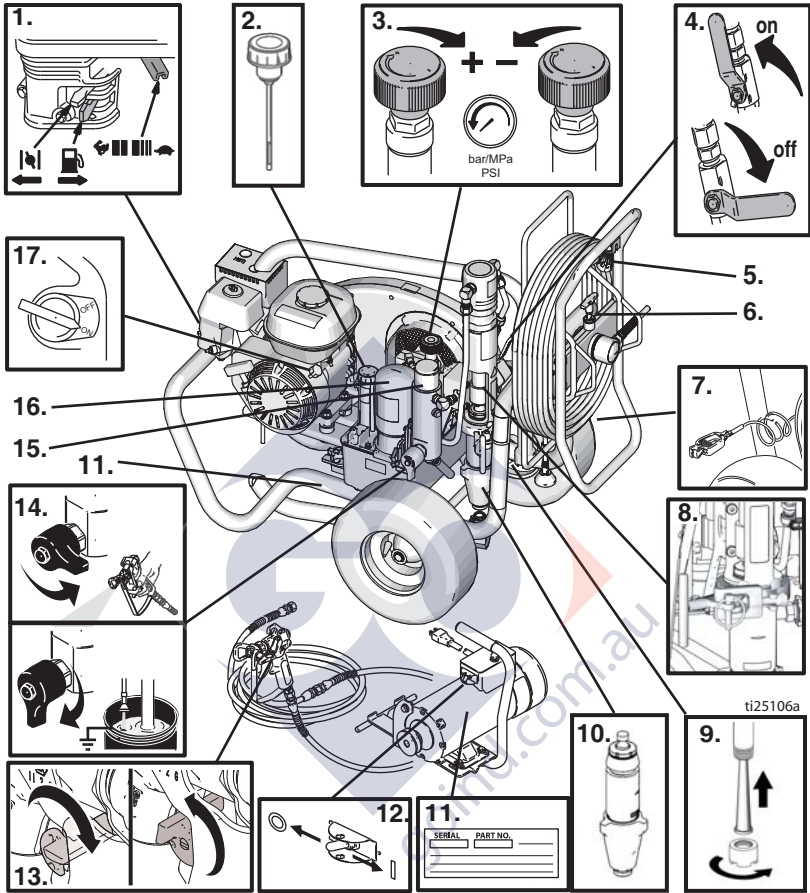

1	Engine Controls
2	Hydraulic Oil Cap / Dipstick
3	Pressure Control
4	Hydraulic Pump Valve
5	Hose Reel Handle
6	Hose Reel Lock
7	Grounding Clamp
8	ProConnect
9	Inlet Strainer
10	Displacement Pump

11	Serial Number Tag (2 places)
12	Electric Motor On/Off Switch
13	Gun Trigger Lock
14	Prime/Drain Valve
15	Easy Out™ Paint Filter
16	Hydraulic Oil Filter
17	Engine On/Off Switch

Component Identification

ProContractor Models (DH230)

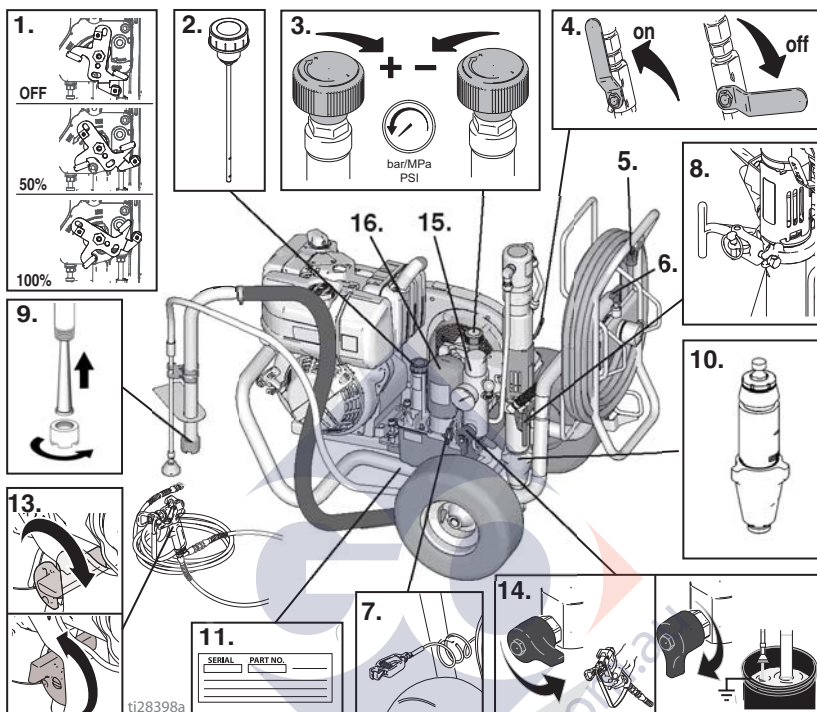

1	Engine Controls
2	Hydraulic Oil Cap / Dipstick
3	Pressure Control
4	Hydraulic Pump Valve
5	Hose Reel Handle
6	Hose Reel Lock
7	Grounding Clamp
8	ProConnect

9	Inlet Strainer
10	Displacement Pump
11	Serial Number Tag
13	Gun Trigger Lock
14	Prime/Drain Valve
15	Easy Out™ Paint Filter
16	Hydraulic Oil Filter

Grounding

Grounding Procedure for Internal Combustion Engine



The equipment must be grounded to reduce the risk of static sparking. Static sparking can cause fumes to ignite or explode. Grounding provides an escape wire for the electric current.

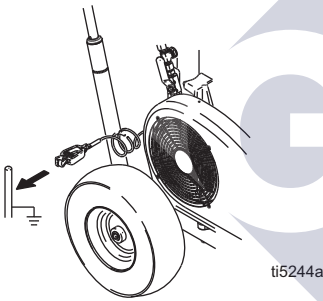

ti5244a

To ground sprayer: Attach sprayer grounding clamp to earth ground.

Air and fluid hoses: Use only electrically conductive hoses with a maximum of 500ft. (150 m) combined hose length to ensure grounding continuity. Check electrical resistance of hoses. If total resistance to ground exceeds 29 megohms, replace hose immediately.

Spray gun: Ground through connection to a properly grounded fluid hose and pump.

Grounding Procedure for Electric Motor



The equipment must be grounded to reduce the risk of static sparking and electric shock. An electric or static spark can cause fumes to ignite or explode. An improper ground can cause electric shock. A good ground provides an escape wire for the electric current.

If using the electric motor, plug must be plugged into an actual outlet that is properly installed and grounded in accordance with all local codes and ordinances.

Do not modify the plug provided; if it does not fit the outlet, have the proper outlet installed by a qualified electrician.

Power Requirements

- 110-120V units require 100-120 VAC, 50/60 Hz, 15A, 1 phase.
- 230V units require 230 VAC, 50/60 Hz, 16A, 1 phase

Extension Cords

Use an extension cord with an undamaged ground contact. If an extension cord is necessary, use a 3-wire, 12 AWG (2.5 mm²) minimum.

NOTE: Smaller gauge or longer extension cords may reduce sprayer performance.

Grounding

Grounding of Pails

Solvent pails used when flushing: Follow local code. Use only conductive metal pails, placed on a grounded surface. Do not place the pail on a non-conductive surface, such as paper or cardboard, which interrupts grounding continuity.



Always ground a metal pail: connect a ground wire to the pail. Clamp one end to the pail and the other end to a true earth ground such as a water pipe.

To maintain ground continuity when sprayer is flushed or pressure is relieved: hold metal part of spray gun firmly to the side of a grounded metal pail then trigger the gun.

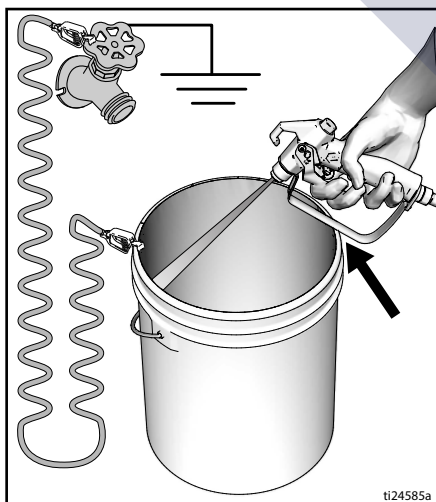

Pressure Relief Procedure



Follow the Pressure Relief Procedure whenever you see this symbol.

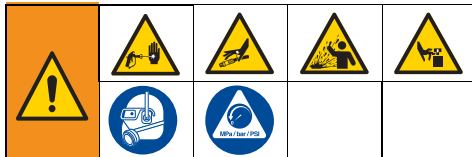

This equipment stays pressurized until pressure is manually relieved. To help prevent serious injury from pressurized fluid, such as skin injection, splashing fluid and moving parts, follow the **Pressure Relief Procedure** when you stop spraying and before cleaning, checking, or servicing the equipment.

1. Engage trigger lock.
2. Turn sprayer OFF:
 - Turn gas engine or electric motor ON/OFF switch to OFF.
 - OR
 - Move Diesel throttle lever to STOP.
 - OR
 - Unplug power cord to electric motor.
3. Move pump valve to OFF and turn pressure control knob fully counter-clockwise to lowest setting.
4. Disengage trigger lock. Hold metal part of gun firmly to side of grounded metal pail, and trigger gun to relieve pressure.
5. Engage gun trigger lock.
6. Turn prime valve down to DRAIN position. Leave prime valve down until ready to spray again.
7. If you suspect the spray tip or hose is clogged or that pressure has not been fully relieved:
 - a. VERY SLOWLY loosen tip guard retaining nut or hose end coupling to relieve pressure gradually.
 - b. Loosen nut or coupling completely.
 - c. Clear hose or tip obstruction.

Setup

Change Engine or Motor

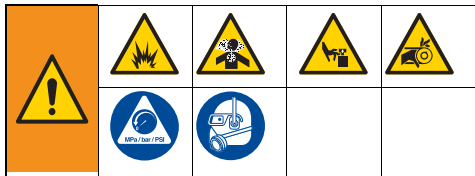

- 1 Turn motor OFF and unplug or turn engine to the OFF/STOP position. Loosen belt guard knob and motor clamp. Perform **Pressure Relief Procedure**, page 13.

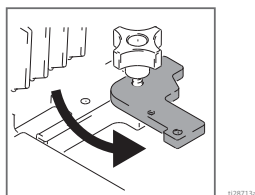
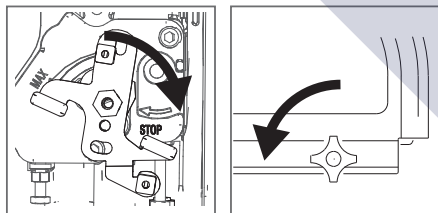
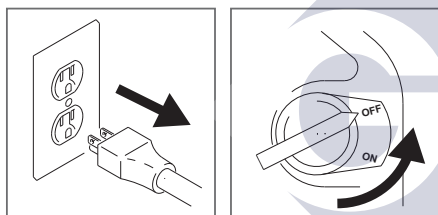

- 2 Lift belt guard. Remove belt. Tilt engine/motor and remove engine/motor.

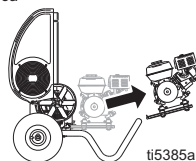
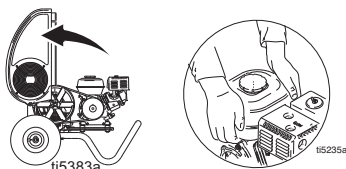

- 3 Tilt engine/motor. Install engine/motor. Install belt. Lower belt guard.

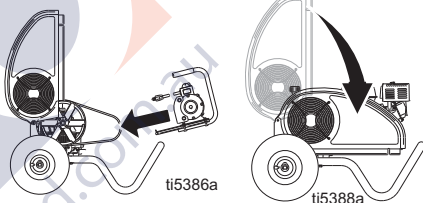

- 4 Swivel motor clamp. Tighten motor clamp and belt guard knob.

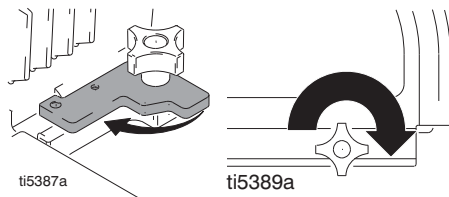

Setup

Complete Setup



1. **All sprayers except ProContractor:** Connect appropriate Graco high-pressure hose to sprayer.

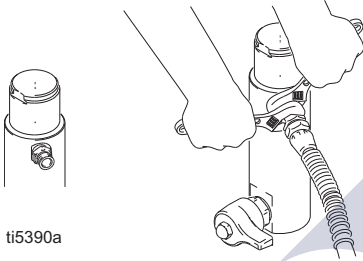

2. Install hose to spray gun and tighten securely.

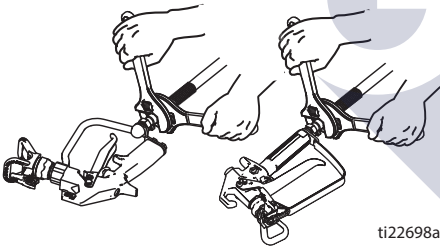

3. Engage gun trigger lock.

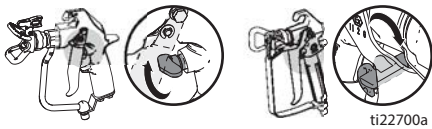

4. Remove Tip Guard.

5. **ProContractor Series:** Install inlet strainer into bottom of suction tube, place inlet nut over end and hand tighten securely.

Standard Series: Screw inlet strainer to bottom of suction hose and hand tighten securely.

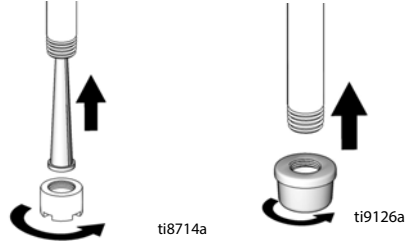

6. When spraying texture, remove inlet strainer and filter bowl screen.

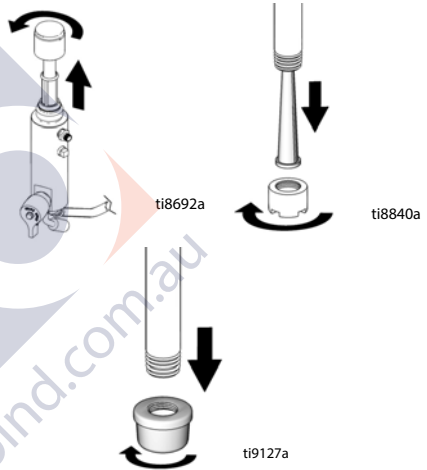

7. Fill throat packing nut with TSL to prevent premature packing wear. Do this each time you spray.

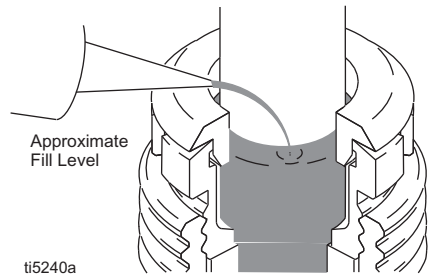

8. Check engine oil level.

Gasoline Engine

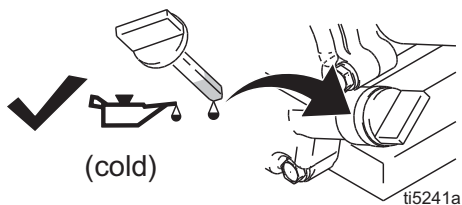

Diesel Engine

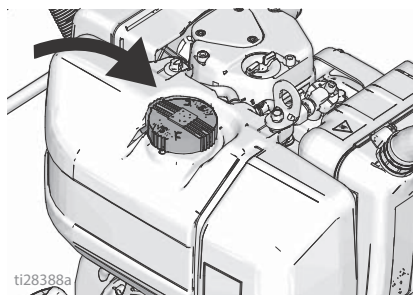

Diesel Engine

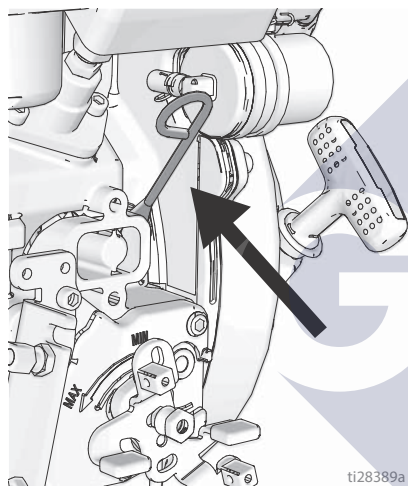

10. Check hydraulic oil level. Add Graco Hydraulic Oil, ISO Grade 46, 169236 (5 gallon/18.9 liter) or 207428 (1 gallon/3.8 liter). Hydraulic tank capacity is 1.25 gallon (4.75 liters).



Safe Range (cold)

9. Fill fuel tank.

Gasoline Engine

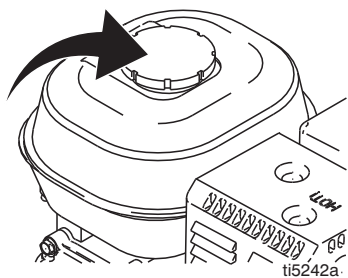

11. Attach sprayer grounding clamp to earth ground.

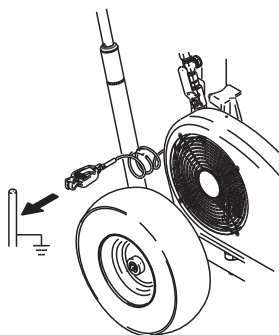

Startup

Startup



1. Place suction tube and drain tube in grounded metal pail partially filled with flushing fluid. Attach ground wire to pail and to earth ground.

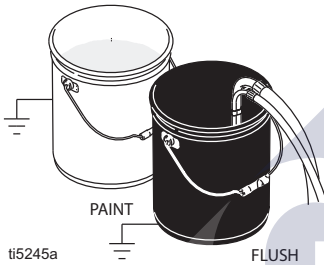

2. Turn prime valve down to DRAIN position. Turn pressure control counter-clockwise to lowest pressure.



3. Set hydraulic pump valve OFF.

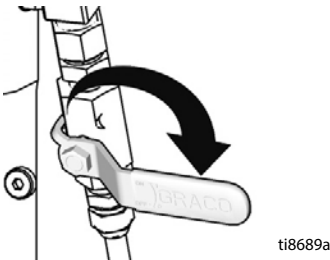

4. If using electric motor, plug cord into outlet and turn switch to ON.

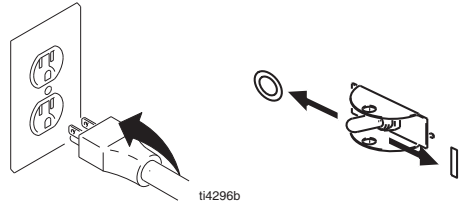

5. If using gasoline engine, start engine.
 - a. Move fuel valve to open.

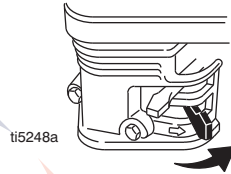

- b. Move choke to closed.

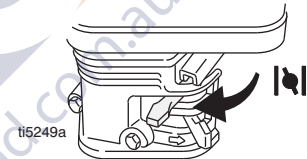

- c. Set throttle to fast.

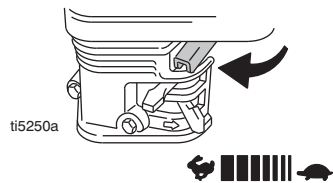

- d. Set engine switch to ON.

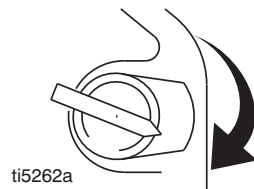

- e. Pull starter rope.

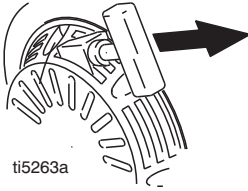

- f. After engine starts, move choke to open.

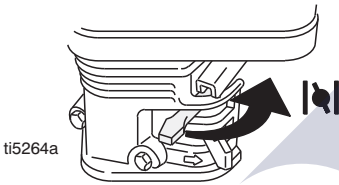

- g. Set throttle to desired setting.



6. If using Diesel engine, start engine.
a. Move throttle lever to MIN position.

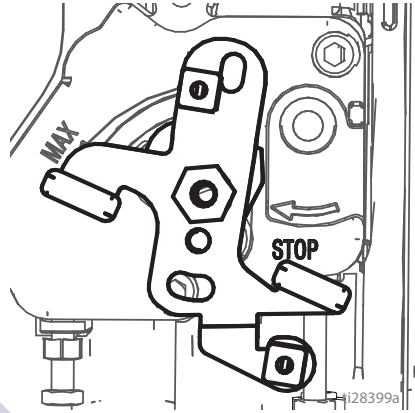

- b. Grip the starter rope handle. Gently pull the rope until it is extended to the full length revealing the RED indicator mark on the rope.

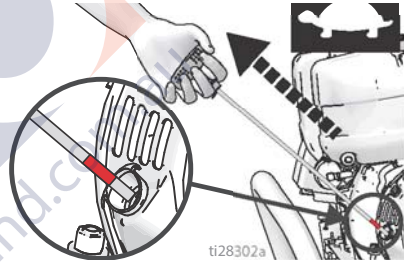

- c. Without releasing the starter rope handle allow the rope to rewind completely.

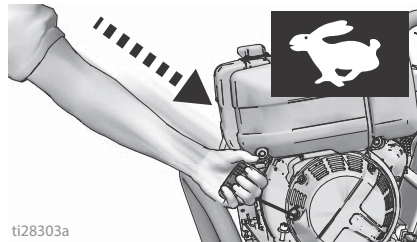

Startup

- d. Start the engine by pulling the rope using a firm steady pull.

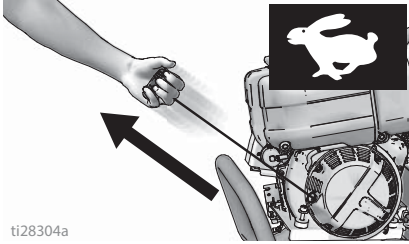

- e. After engine starts move throttle lever to MAX (full throttle) position.

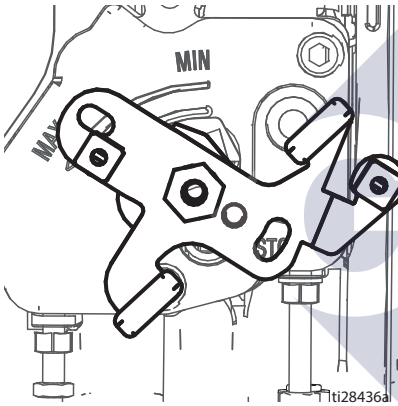

7. Set hydraulic pump valve ON (hydraulic motor is now active).

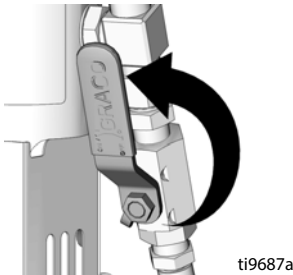

8. Increase pressure enough to start hydraulic motor stroking and allow fluid to circulate for 15 seconds; turn pressure down, turn prime valve horizontal.

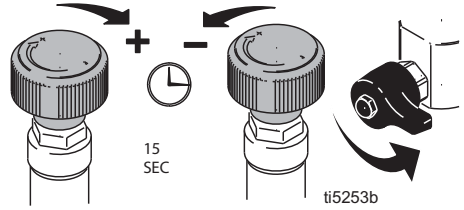

9. Disengage spray gun trigger lock.

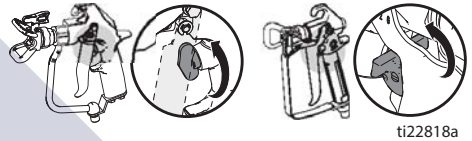

10. Hold gun against grounded metal flushing pail. Trigger gun and increase fluid pressure slowly until pump runs smoothly. Release trigger and allow sprayer to build pressure. Engage trigger lock.

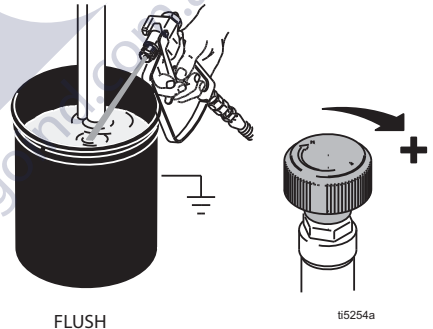

				
High-pressure spray is able to inject toxins into the body and cause serious bodily injury. Do not stop leaks with hand or rag.				

Switch Tip™ and Guard Assembly

				
---	---	---	---	--

11. Inspect for leaks. If leaks occur, turn sprayer OFF immediately. Perform **Pressure Relief Procedure**, page 13. Tighten leaky fittings. Repeat **Startup** procedure steps 2-8. If no leaks, continue to trigger gun until system is thoroughly flushed.
12. Place siphon tube in paint pail.

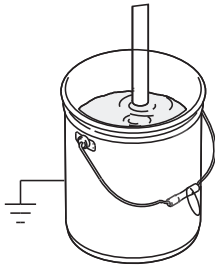

PAINT

ti5255a

13. Trigger gun again into flushing fluid pail until paint appears.



FLUSH

ti5256a

1. Perform **Pressure Relief Procedure**, page 13.
2. Engage gun trigger lock. Insert Switch Tip. Insert seat and OneSeal™.

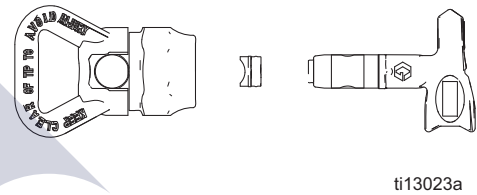

3. Insert Switch Tip and face forward.

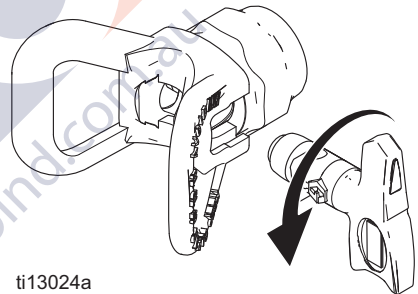

4. Screw assembly onto gun. Tighten.

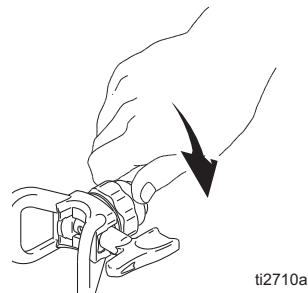

Startup

Spray

1. Spray test pattern. Increase pressure to eliminate heavy edges. Use smaller tip size if pressure adjustment can not eliminate heavy edges.

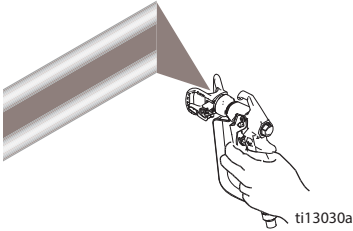

2. Hold gun perpendicular, 10-12 in. (25-30 cm) from surface. Spray back and forth. Overlap by 50%. Trigger gun after moving and release before stopping.

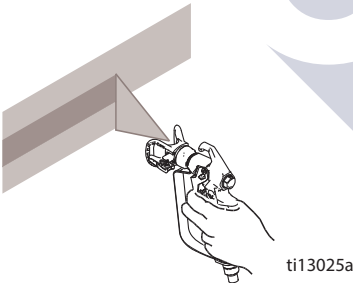

Clear Tip Clog



1. Release trigger, engage trigger lock. Rotate Switch Tip. Disengage trigger lock. Trigger gun to clear clog.

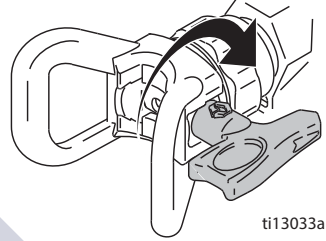

2. Engage trigger lock. Return Switch Tip to original position. Disengage trigger lock and continue spraying.

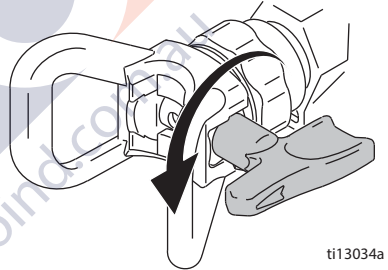

Hose Reel

(ProContractor Series only)



1. Make sure hose is routed through hose guide.

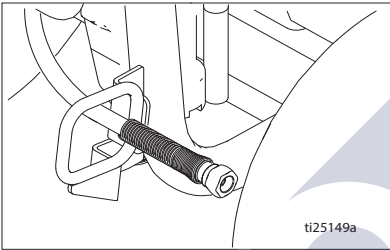

2. Lift and turn pivot lock 90° to unlock hose reel. Pull on hose to remove it from hose reel.

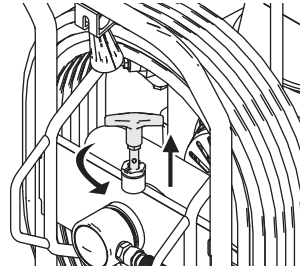

3. Pull reel handle down and turn clockwise to reel in hose.

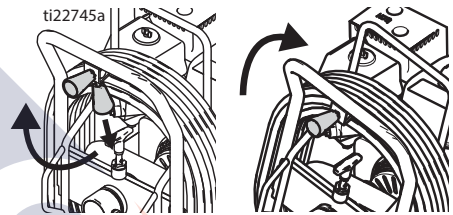

NOTE: The hose reel can be locked into two positions: Usage and Storage.

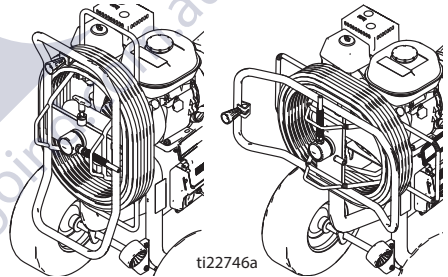

Clean Up

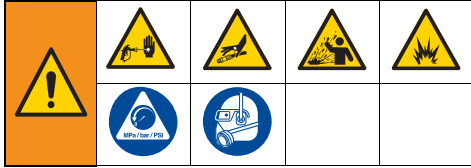

1. Perform **Pressure Relief Procedure**, page 13, steps 1-7.
2. Remove Guard and SwitchTip.

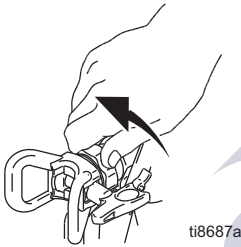

3. Remove siphon tube set from paint and place in flushing fluid. Use water for water-based paint and mineral spirits for oil based paint.

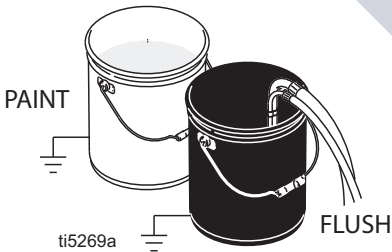

4. Turn engine ON and start engine or plug motor in and turn ON. Move throttle to MAX on internal combustion engine. Turn hydraulic pump valve ON. Turn prime valve to SPRAY position.

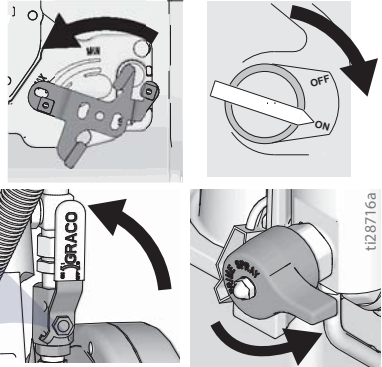

5. Hold gun against pail. Disengage trigger lock. Turn pressure control up until motor begins to drive pump. Trigger gun until flushing fluid appears.

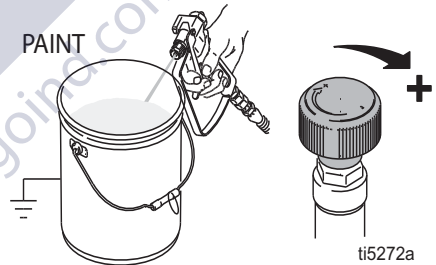

6. Move gun to waste pail, hold gun against pail, trigger gun to thoroughly flush system. Release trigger and engage trigger lock.

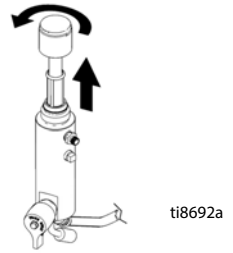
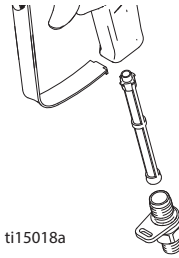
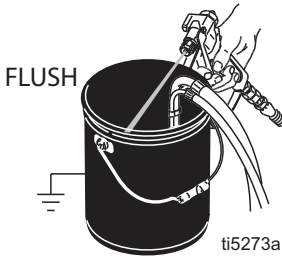

7. While continuing to trigger gun, turn prime valve down. Then release gun trigger. Allow flushing fluid to circulate until fluid comes out of drain tube clear.

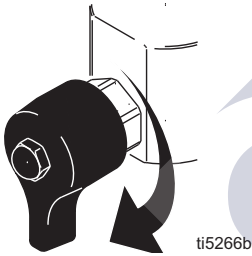

8. Raise siphon tube above flushing fluid and run sprayer for 15 to 30 seconds to drain fluid. Turn hydraulic valve OFF. Turn engine OFF or turn electric motor OFF and unplug.

10. Depending on model, either remove nut and inlet strainer screen from bottom of suction tube, or unscrew and remove inlet strainer. Clean and replace strainer screen if necessary. Reassemble.

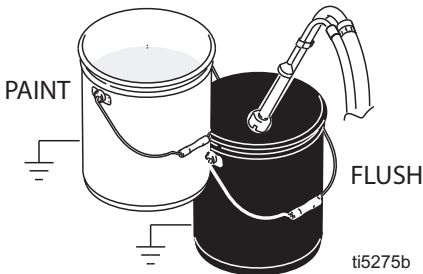
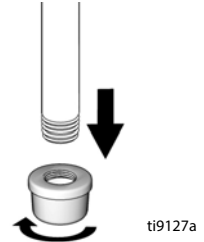

11. If flushing with water, flush again with mineral spirits, or Pump Armor, to leave a protective coating to prevent freezing or corrosion.
12. Wipe sprayer, hose and gun with a rag soaked in water or mineral spirits.

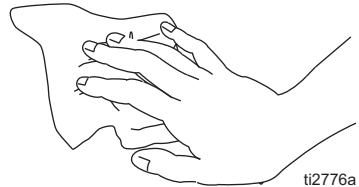

9. Engage trigger lock. Remove filters from gun and sprayer, if installed. Clean and inspect. Reinstall filters.

Maintenance

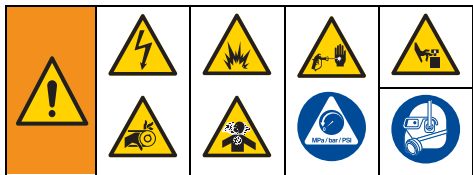

NOTE: For detailed engine maintenance and specifications, refer to separate Honda or Kohler Engine Owner's Manual, supplied.

DAILY: Check engine oil level and fill as necessary.

DAILY: Check hydraulic oil level and fill as necessary.

DAILY: Check hose for wear and damage.

DAILY: Check gun trigger lock for proper operation.

DAILY: Check prime/drain valve for proper operation.

DAILY: Check and fill the fuel tank.

DAILY: Check that displacement pump is tight.

DAILY: Check level of Throat Seal Liquid (TSL) in displacement pump packing nut. Fill nut, if necessary. Keep TSL in nut to help prevent fluid buildup on piston rod and premature wear of packings and pump corrosion.

GASOLINE ENGINE, AFTER THE FIRST 20 HOURS OF OPERATION: Drain engine oil and refill with clean oil. Reference Honda Engine Owner's Manual for correct oil grade.

DIESEL ENGINE, AFTER THE FIRST 50 HOURS OF OPERATION: Drain engine oil and refill with clean oil. Replace oil filter. Reference Kohler Engine Owner's Manual for correct oil grade.

WEEKLY: Remove engine air filter cover and clean element. Replace element, if necessary. If operating in an unusually dusty environment: check filter daily and replace, if necessary.

Replacement elements can be purchased from your local HONDA/Kohler dealer.

WEEKLY/DAILY: Remove any debris or media from hydraulic rod.

AFTER EACH 100 HOURS OF OPERATION: Change engine oil. Reference Honda Engines Owner's Manual for correct oil viscosity.

DIESEL ENGINE, AFTER EACH 250 HOURS OF OPERATION: Drain engine oil and refill with clean oil. Replace oil filter. Reference Kohler Engine Owner's Manual for correct oil grade.

SEMI-ANNUALLY: Check belt wear. Replace if necessary.

YEARLY OR 2000 HOURS: Replace hydraulic oil and filter with Graco hydraulic oil 169236 (5 gallon/20 liter) or 207428 (1 gallon/3.8 liter) and filter 116909.

Replace belt.

SPARK PLUG: Use only BPR6ES (NGK) or W20EPR-U (NIPPONDENSO) plug. Gap plug to 0.028 to 0.031 in. (0.7 to 0.8 mm). use spark plug wrench when installing and removing plug.

Troubleshooting



Problem	Cause	Solution
Internal combustion engine pulls hard (won't start)	Hydraulic pressure is too high	Turn hydraulic pressure knob counterclockwise to lowest setting
Gasoline engine does not start	Switch OFF, low oil, no gasoline	Consult engine manual
	Fuel shut off valve closed	Open fuel shut off valve
Gasoline engine does not work properly	Faulty engine	Consult engine manual
	Elevation	Refer to Engine Repair Kit, 4.0 hp - 288678 / 5.5 hp - 248943 / 6/5 hp - 248944 / 9.0 hp - 248945
Diesel engine does not start	No fuel Incorrect injection timing, rings worn or sticking.	Consult engine manuals
Diesel engine does not work properly	Faulty engine	Consult engine manuals
	Poor fuel quality	Drain fuel tank and replace fuel with good clean fuel
Internal combustion engine operates, but displacement pump does not operate	Hydraulic pump valve is OFF	Set hydraulic pump valve ON
	Pressure setting too low	Increase pressure, page 20.
	Displacement pump outlet filter (if used) is dirty or clogged	Clean the filter
	Tip or tip filter (if used) is clogged	Remove tip and/or filter and clean
	Hydraulic fluid too low	Shut off sprayer. Add fluid*. See page 17.
	Belt worn or broken or off	Replace.
	Hydraulic pump worn or damaged	Bring sprayer to Graco distributor for repair
	Dried paint seized paint pump rod	Service pump. See manual 334654
Displacement pump operates, but output is low on upstroke	Hydraulic motor not shifting	Set pump valve OFF. Turn pressure down. Turn engine OFF. Pry rod up or down until hydraulic motor shifts.
	Piston ball check not seating properly	Service piston ball check. See manual 334654
	Piston packings worn or damaged	Replace packings. See manual 334654

Troubleshooting

Problem	Cause	Solution
Displacement pump operates, but output is low on down stroke and/or on both strokes	Piston packings worn or damaged	Tighten packing nut or replace packings. See manual 334654
	Intake valve ball check not seating properly	Service intake valve ball check. See manual 334654
	Suction tube air leak	
	Hydraulic oil filter is dirty	Replace filter.
Paint leaks and runs over side of wet cup	Loose wet cup	Tighten wet cup enough to stop leakage
	Throat packings worn or damaged	Replace packings. See manual 334654
Excessive leakage around hydraulic motor piston rod wiper	Piston rod seal worn or damaged	Replace these parts. See manual 334654
Fluid delivery is low	Pressure setting too low	Increase pressure, page 20.
	Displacement pump outlet filter (if used) is dirty or clogged	Clean or replace.
	Contractor gun filter (if used) is dirty or clogged	Clean or replace.
	Intake line to pump inlet is not tight	Tighten.
	Hydraulic motor is worn or damaged	Bring sprayer to Graco distributor for repair.
	Large pressure drop in fluid hose	Reduce length or increase diameter.
The sprayer overheats	Paint buildup on hydraulic components	Clean
	Oil level is low	Fill with oil. See page 17.
Spitting from gun	Air in fluid pump or hose	Check for loose connections on siphon assembly, tighten, then reprime pump
	Loose intake suction	Tighten
	Fluid supply is low or empty	Refill supply container
Pump noise	Low hydraulic fluid level	Turn sprayer OFF. Add fluid*. See page 17
Electric motor does not operate	Power switch is not ON	Turn power switch ON
	Tripped circuit breaker	Check circuit breaker at power source. Reset motor switch
*Check hydraulic fluid level often. Do not allow it to become too low. Use only Graco hydraulic fluid, page 17.		

Standard Series Pump

Removal



See pump manual 334654 for pump repair.

1. Flush pump.
2. Perform **Pressure Relief Procedure**, page 14.
3. Remove suction tube and paint hose (remove at swivel end).

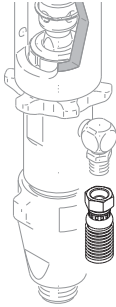

ti2272a

4. Push retaining ring up; push out pin.

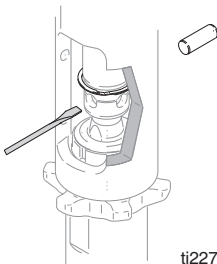

ti2272b

5. Loosen jam nut. Unscrew pump.

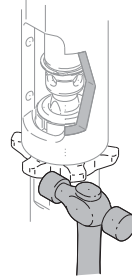

ti2272c

Installation

NOTICE

If pump jam nut loosens during operation, the threads of the bearing housing and drive train will be damaged. Tighten jam nut as specified.

1. Screw jam nut to bottom of pump threads. Screw pump completely into manifold. Unscrew pump from manifold until pump outlet aligns with hose. Hand tighten jam nut, then tap 1/8 to 1/4 turn with hammer.

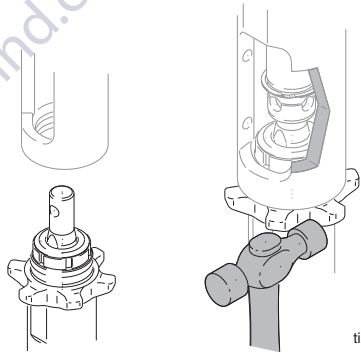

ti2272d

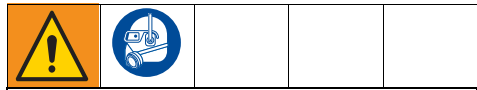

If pin is loose, parts could break off and project through the air, resulting in serious injury or property damage. Make sure pin is properly installed.

ProContractor Series Pump

2. Slowly pull engine starter rope until pump rod pin hole is aligned with hydraulic rod hole. Push pin into hole. Push retaining ring into groove.

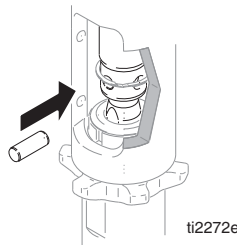

3. Fill packing nut with Graco TSL.

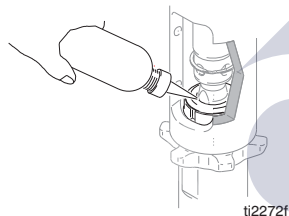

ProContractor Series Pump

Removal



See pump manual 334654 for pump repair.

1. Flush pump.
2. Perform **Pressure Relief Procedure**, page 13.
3. Remove suction hose.

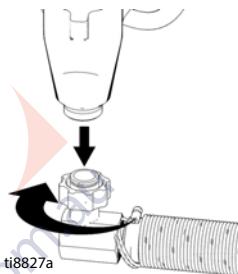

4. Remove paint hose fitting and paint hose from pump fitting.

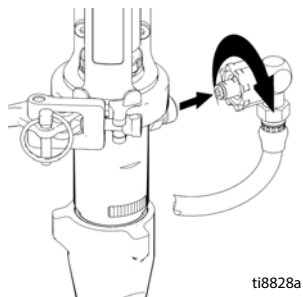

ProContractor Series Pump

- Slide coupler cover up to fully expose rod couplers.

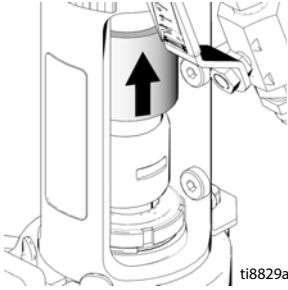

- Open clamp.

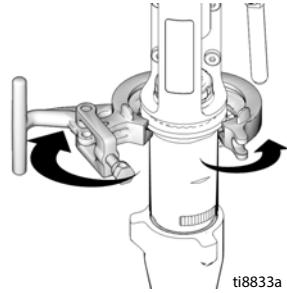

- Remove rod couplers.

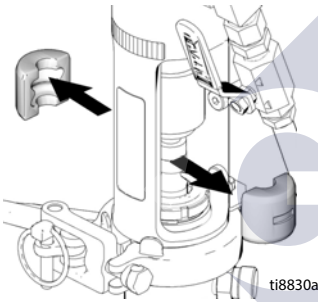

- Remove pump from unit.

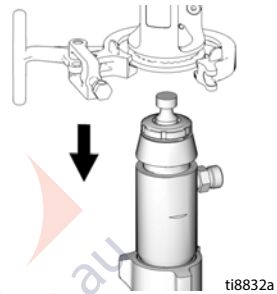

- Remove pin.

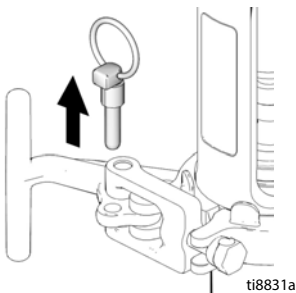

Installation

- If needed, place pump rod in adjustment casting and pull pump to extend rod.

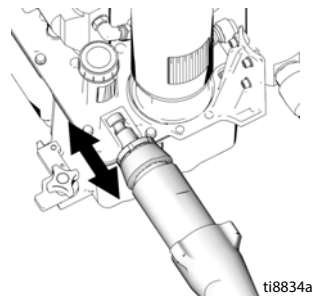

NOTE: Support pump with your hand before opening t-handle.

- Reverse removal steps to reassemble pump.

GH™ 130/200/230/300 Standard Series Parts

GH™ 130/200/230/300 Standard Series Parts

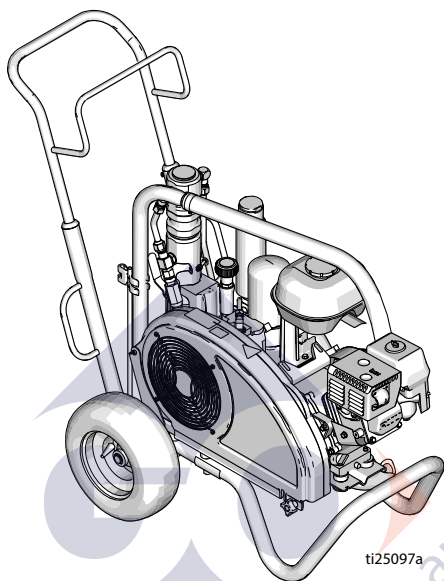

goind.com.au

GH™ 130/200/230/300 Standard Series Parts

GH™ 130/200/230/300 Standard Series

Ref.	Torque	Ref.	Torque
	120-130 in-lb (13.6 - 14.7 N•m)		15-25 in-lb (1.7 - 2.8 N•m)
	Inflate tires to 25-35 psi (1.7-2.4 bar)		Apply Locktite 242
	110-120 in-lb (12.4 - 13.6 N•m)		35-45 ft-lb (47.5 - 61.0 N•m)
	355-395 in-lb (40.1 - 44.6 N•m)		

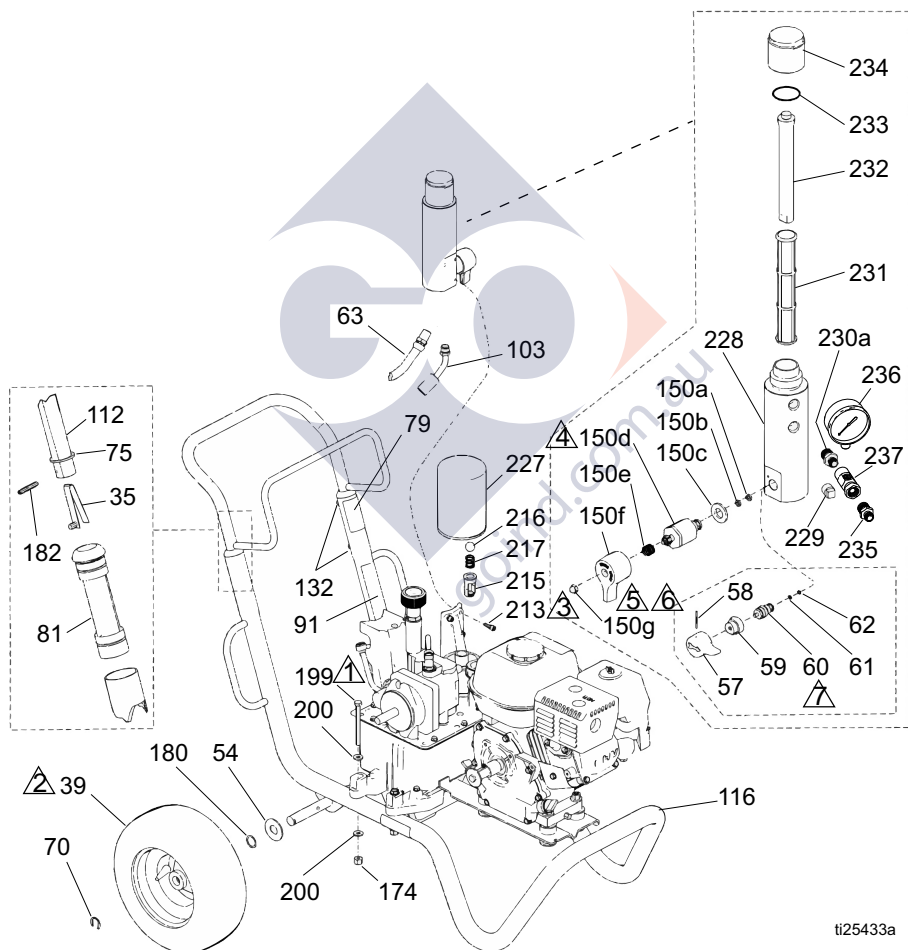

ti25433a

GH™ 130/200/230/300 Standard Series Parts

Parts List

Ref.	Part	Description	Qty.	Ref.	Part	Description	Qty.
35	112827	BUTTON, snap	2	150d★		VALVE, assembly	1
39	119420	WHEEL, pneumatic, GH130 & 200	2	150e★	114708	SPRING, compression	1
	119509	WHEEL, pneumatic, GH230 & 300	2	150f★	15G563	HANDLE, valve	1
54	156306	WASHER, flat	2	150g★	116424	NUT, cap, hex hd	1
57	15C780	HANDLE, GH130	1	174	110838	NUT, hex	2
58	15C972	PIN, grooved, GH130	1	180	116038	WASHER, wave spring	2
59	224807	BASE, valve, GH130	1	182	101354	PIN, spring, straight, GH130 & 200	2
60	235014	VALVE, replacement, kit, GH130	1		108068	PIN, spring, straight, GH230 & 300	2
61◆	15E022	SEAT, valve, GH130	1	199	867539	SCREW, flat head	2
62◆	277364	GASKET, seat, valve, GH130	1	200	100527	WASHER	4
63	243814	HOSE	1	213	119426	SCREW	3
70	120211	CLIP, retaining	2	215	198841	RETAINER	1
75	15J645	WASHER, GH130 & 200	2	216	100084	BALL, metallic	1
	183350	WASHER, GH230, & 300	2	217	116967	SPRING, compression	1
79▲	189246	LABEL, warning	1	227	246173	FILTER, oil, spin on	1
	17D947	LABEL, warning, multi-languages	1	228‡	15E599	HOUSING	1
				229‡	15G331	PLUG, pipe	1
81	192027	SLEEVE, cart	2	230a	196178	ADAPTER 3/8 npsm (m) hose connection	1
91▲	194317	LABEL, warning	1	231‡	244067	FILTER, fluid	1
	16N948	LABEL, warning, ISO	1	232‡	15C766	TUBE, diffusion	1
	17D947	LABEL, warning, multi-languages	1	233‡	117285	PACKING, o-ring	1
103	288732	HOSE, drain	1	234‡	15C765	CAP, filter	1
112	24M397	HANDLE, cart	1	235	196177	ADAPTER, GH130/200	1
116	288169	FRAME, cart, GH130 & 200	1		196178	ADAPTER, GH230/300	1
	248815	CART, frame, GH230 & 300	1	236	102814	GAUGE, press, fluid	1
132	109032	SCREW, mach, pnh	4	237	243683	SWIVEL	1
150‡	245103	VALVE, drain, GH200, 230, 300					
150a★	193710	SEAL, valve	1				
150b★	193709	SEAT, valve	1				
150c★	114797	GASKET	1				

▲ *Danger and Warning labels are available at no cost.*

◆ *Included in Drain Valve Replacement Kit 235014*

★ *Included in Drain Valve Replacement Kit 245103*

‡ *Included in Filter Replacement Kit 24W753*

GH™ 130/200/230/300 Standard Series Parts

Parts-Engines

GH™ 130/200/230 Standard Series

Ref.	Torque	Ref.	Torque
	120-130 in-lb (13.6 - 14.7 N•m)		Apply Locktite 242
	58-62 in-lb (6.6 - 7.0 N•m)		

GH™ 130/200/230 Standard Series

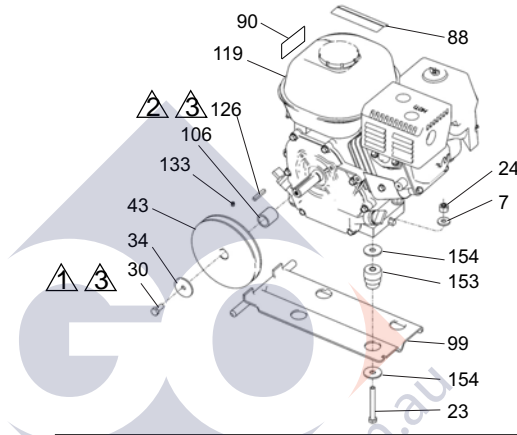

GH™ 300 Standard Series

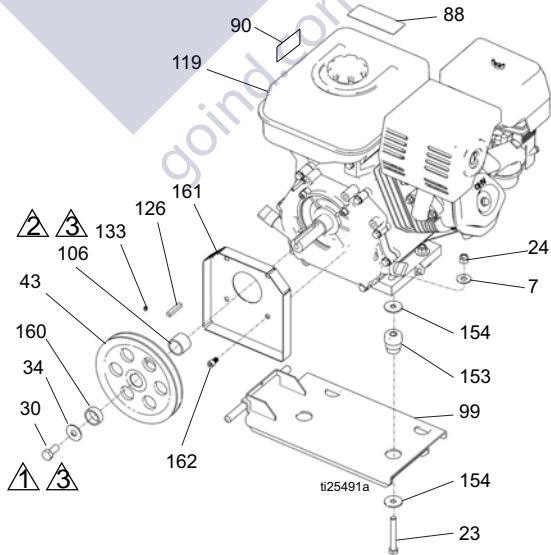

GH™ 130/200/230/300 Standard Series Parts

Parts List Engines

Ref.	Part	Description	Qty.	Ref.	Part	Description	Qty.
7	100023	WASHER, flat, GH130, 200 & 230	4	119*	120590	ENGINE, gasoline, 120 cc, Honda, GH130	1
	100132	WASHER, flat, GH300	4		802264	ENGINE, gasoline, 160 cc, GH200	1
23	113664	SCREW, cap, hex hd, GH130, 200 & 230	4		116298	ENGINE, gasoline, 200 cc, Honda, GH230	1
	106212	SCHREW, cap, hex hd, GH300	4		803900	ENGINE, gasoline, 270 cc, Honda, GH300	1
24	110838	NUT, lock, GH130, 200 & 230	4	126	117632	KEY, square, 3/16 X 1.25, GH130, 200 & 230	1
	101566	NUT, lock, GH300	4		119484	KEY, parallel, square, GH300	1
30	108842	SCREW, cap, hex hd, GH130, 200 & 230	1	133	100002	SCREW, set, sch	1
	116645	SCREW, cap, hex hd, GH300	1	153	15E888	DAMPENER, motor mount, GH130, 200 & 230	4
34	112717	WASHER, GH130, 200 & 230	1		195515	DAMPENER, motor mount, GH300	4
	119438	WASHER, GH300	1	154	108851	WASHER, plain	8
43	116908	PULLEY, 5.50 in, GH130, 200 & 230	1	160	15E764	SPACER, GH300	1
	119401	PULLEY, GH300	1	161	15E973	SHIELD, GH300	1
88▲	194126	LABEL, warning	1	162	C20010	SCREW, GH300	4
	16Y631	LABEL, warning, Chinese	1				
90▲	16Y720	LABEL, warning, ISO engine	1				
99	15F157	BRACKET, mounting, engine, GH130, 200 & 230	1				
	15E583	BRACKET, mounting, engine, GH300	1				
106	15B314	SLEEVE, motor shaft, GH130, 200 & 230	1				
	15E586	SLEEVE, motor shaft, GH300	1				

▲ Danger and Warning labels are available at no cost.







*Engine Repair Kits:

288678	120 cc (4.0 HP)
248943	160 cc (5.5 HP)
248944	200 cc (6.5 HP)
248945	270 cc (9.0 HP)

GH™ 130/200/230/300 Standard Series Parts

Parts - Fan Belt

GH™ 130/200/230/300 Standard Series

Ref.	Torque	Ref.	Torque
	120-130 in-lb (13.6 - 14.7 N•m)		90-110 in-lb (10.2 - 12.4 N•m)
	Apply Locktite 242		Apply Locktite 277
	55-62 in-lb (6.7 - 7.0 N•m)		110-120 in-lb (12.4 - 13.6 N•m)

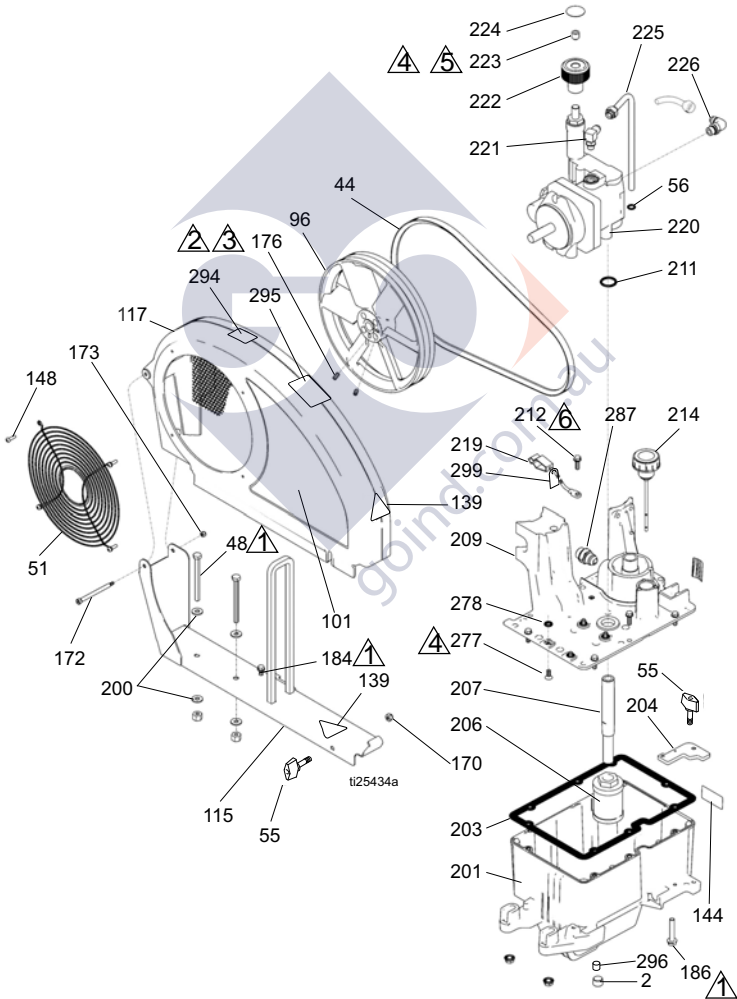

GH™ 130/200/230/300 Standard Series Parts

Parts List

Ref.	Part	Description	Qty.	Ref.	Part	Description	Qty.
2	101754	PLUG	1	203	120604	GASKET, reservoir	1
44	119433	BELT, GH130, 200, 230	1	204	15E476	BRACKET, retainer, motor	1
	119432	BELT, GH300	1	206	116919	FILTER	1
48	867539	SCREW, hex head	2	207	15E587	TUBE, suction	1
51	117284	GRILL, fan guard	1	208	154594	PACKING, o-ring	1
55	17D813	NUT, hand	2	209	15J363	COVER, reservoir	1
56	154594	O-RING	1	211	156401	PACKING, o-ring	1
96	15E410	PULLEY, fan	1	212	119426	SCREW	8
101	17D031	LABEL, GH130	1	214	120726	CAP, breather, filler	1
	17D032	LABEL, GH200	1	219	237686	WIRE, ground with clamp	1
	17D034	LABEL, GH230	1	220	288733	PUMP, hydraulic, GH130	1
	17D036	LABEL, GH300	1		246178	PUMP, hydraulic, GH200	1
115	288261	RAIL, belt guard, assembly, GH130 & 200	1		249003	PUMP, hydraulic, 230/300	1
	288393	RAIL, belt guard, assembly, GH230 & 300	1	221	110792	FITTING, elbow, male, 90°	1
117	288734	GUARD, belt assembly, painted, GH130 & 200	1	222	15B438	KNOB, pressure	1
	248973	GUARD, belt, assembly, painted, GH230 & 300	1	223	117560	SCREW, set, socket head	1
139▲	16M768	LABEL, warning	2	224	15A464	LABEL, control	1
144	15K440	LABEL, GH/EH cooling system	1	225	246167	TUBE, hydraulic, case drain	1
148	115477	SCREW, mach, torx pan hd	4	226	116829	FITTING, elbow, with o-rings	1
170	102040	NUT, lock, hex	1	277	117471	SCREW	4
172	119434	SCREW, shoulder, socket head	1	278	107188	PACKING, o-rings	4
173	116969	NUT, lock	1	284	16P142	LABEL, hydraulic fluid, GH	1
176	120087	SCREW, set, 1/4 X 1/2	2	287	120184	FITTING	1
184	260212	SCREW, hex washer hd, thd form	1	294	16D576	LABEL, made in USA	1
186	120655	SCREW, mach, hex washer head	2	295	16X983	LABEL, standard series	1
200	100527	WASHER	4	296	116618	MAGNET	1
201	15J513	TANK, reservoir	1	299	290079	LABEL, ground warning, English	1
202	101754	PLUG, pipe	1		16Y633	LABEL, ground warning, Chinese	1

▲ Danger and Warning labels are available at no cost.

GH™ 130/200/230/300 Standard Series Parts

Parts

GH™ 130/200/230/300 Standard Series

Ref.	Torque
	70-80 ft-lb (94.9 - 108.5 N•m)

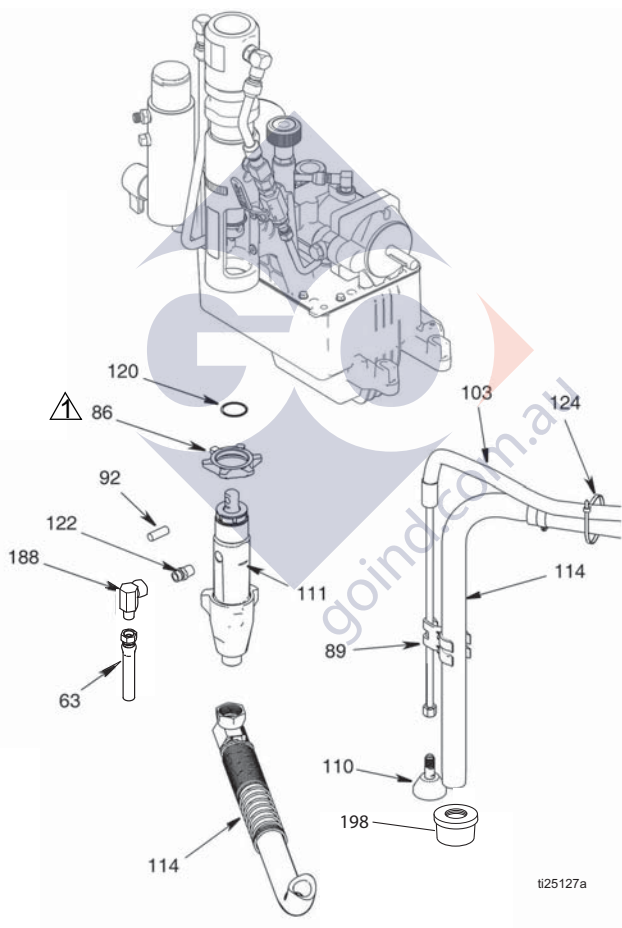

GH™ 130/200/230/300 Standard Series Parts

Parts List



Ref.	Part	Description	Qty.	Ref.	Part	Description	Qty.
63	243814	HOSE, coupled	1	114	288251	HOSE, suction, 5 gallon, GH130	1
86	193031	NUT, retaining, GH130	1		288252	HOSE, suction, 5 gallon, GH200, 230 & 300	1
	193394	NUT, retaining, GH200/230/300	1	115	208259	Hose, suction, 30/55 gallon, GH130 (not shown)	1
89	15D000	CLIP, drain line	1		289669	HOSE, suction, 30/55 gallon, GH200/230/300 (not shown)	1
92	155141	PIN, pump, GH130	1	120	116551	RING, retaining	1
	197443	PIN, pump, GH200/230/300	1	122	196178	ADAPTER, nipple	1
103	288732	KIT, drain hose	1	124	114958	STRAP, tie	4
110	241920	DEFLECTOR, threaded	1	188	155494	UNION, swivel, 90°	1
111	24B748	PUMP, kit, displacement, GH130	1	198	189920	INLET, filter, 8 mesh	1
	24W995	PUMP, kit, displacement, GH200	1				
	24W997	PUMP, kit, displacement, GH230 & 300	1				



GH™ 130/200/230/300 Standard Series Parts

Parts

GH™ 130/200/230/300 Standard Series

Ref.	Torque	Ref.	Torque
	145-155 ft-lb (196.6 - 210.2 N•m)		140-160 in-lb (15.8 - 18.1 N•m)
	12-18 ft-lb (16.3 - 24.4 N•m)		

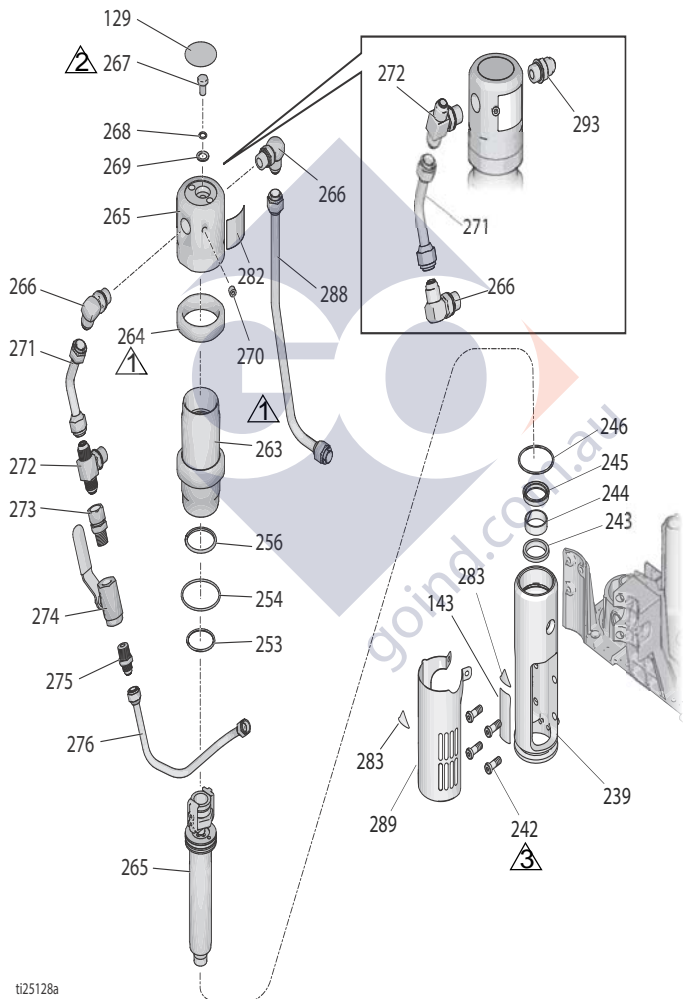

GH™ 130/200/230/300 Standard Series Parts

Parts List

Ref.	Part	Description	Qty.	Ref.	Part	Description	Qty.
129▲◆✓	15B063	LABEL, warning, hot surface	1		15E596	TUBE, hydraulic, supply, GH230 & 300	1
143▲	17D050	LABEL, GH130	1	272◆	117609	FITTING, tee, branch, str thd	1
	17D051	LABEL, GH200	1	273	117328	FITTING, nipple, straight	1
	17D053	LABEL, GH230	1	274	117441	VALVE, ball	1
	17D055	LABEL, GH300	1	275	116813	FITTING, nipple, hydraulic	1
239◆	15H953	MANIFOLD, GH130	1	276	15J819	TUBE, hydraulic, supply, GH130	1
	15A728	MANIFOLD, GH200	1		17D268	TUBE, hydraulic, supply, GH200	1
	15E243	MANIFOLD, GH230 & 300	1		17D270	TUBE, hydraulic, supply, GH230, GH300	1
242◆	15B564	SCREW, cap socket	4	282✓	15B804	LABEL, Graco logo	1
243‡◆	117739	WIPER, rod	1	283▲◆	15H108	LABEL, warning, finger pinch	2
244‡◆	112342	BEARING, rod	1	288	15J824	TUBE, hydraulic, return, GH130	1
245‡◆	112561	PACKING, block	1		17D267	TUBE, hydraulic, return, GH200	1
246‡◆	117283	PACKING, o-ring	2		17D269	TUBE, hydraulic, return, GH230 & 300	1
253‡◆✓	108014	PACKING, o-ring	1	289	24X473	SHIELD, rod, GH130/200	1
254‡◆✓	178226	SEAL, piston	1		24X474	SHIELD, rod, GH230/300	1
256‡◆✓	178207	BEARING, piston	1	293	120184	FITTING, straight, OEM kits only	1
263◆	246176	SLEEVE, hydraulic cylinder, kit, GH130 & 200	1				
	248991	SLEEVE, hydraulic cylinder, kit, GH230 & 300)	1				
264◆	15A726	NUT, jam	1				
265◆	288735	KIT, repair, trip rod, piston; GH130 only	1				
	288754	KIT, repair, trip rod, piston; GH 200 only	1				
	288755	KIT, repair, trip rod, piston; GH 230/300 only	1				
266◆	117607	FITTING, elbow std thd	2				
267✓◆	106276	SCREW, cap, hex head	1				
268✓◆	155685	PACKING, o-ring	1				
269✓◆	178179	WASHER, sealing	1				
270✓◆	100139	PLUG, pipe	1				
271◆	198629	TUBE, hydraulic, supply, GH130 & 200	1				

▲ Danger and Warning labels are available at no cost.

◆ Included in Hydraulic Motor Repair Kit: 288758 - GH130; 248021- GH200; 248977 - GH230 & 300

✓ Included in Trip Rod/Piston Kit: 288735 - GH130; 288754 - GH200; 288755 - GH230 & 300

‡ Included in Seal Kit 246174

GH™ 130/200/230/300 Standard Series Parts

Parts

GH™ 130/200 Standard Series w/ Spray Gun and Hose

Ref.	Part No.	Description	Qty.
202	240794	HOSE, grounded, nylon; 1/4 in. ID; cpld 1/4-18 npsm; 50 foot (15 m); spring guards both ends 3300 psi (227 bar, 22.7 MPa)	1
203	288420	Contractor Spray Gun Includes 517 RAC® X SwitchTip and HandTite™ Guard See 311861 for parts	1

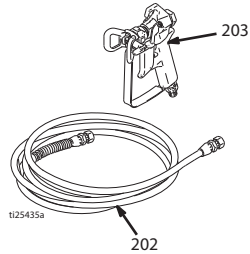

GH™ 230/300 Standard Series w/ Spray Gun and Hose

Ref.	Part No.	Description	Qty.
202	287042	KIT, gun, Silver 3300 psi (227 bar, 22.7 MPa) Includes 202a - 202d	1
202a	240797	HOSE, grounded, nylon; 3/8 in. ID; cpld 3/8-18 npsm; 50 foot (15 m); spring guards both ends 3300 psi (227 bar, 22.7 MPa)	1
202b	241735	HOSE, grounded, nylon; 1/4 in. ID; cpld 1/4 npt(m) x 1/4 npsm(f); 3 foot (0.9 m); spring guards both ends 3300 psi (227 bar, 22.7 MPa)	1
202c	246240	Silver Spray Gun Includes 517 RAC® X SwitchTip and HandTite™ Guard See 311254 for parts	1
202d	159841	3/8 x 1/4 bushing	1

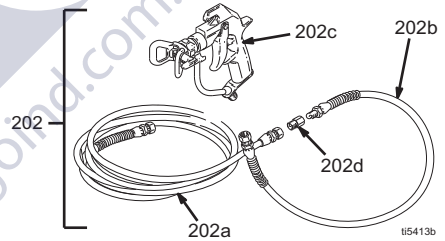

DH230/GH™200/230/300 ProContractor

DH230/GH™200/230/300 ProContractor Series Parts (OEM Kits)

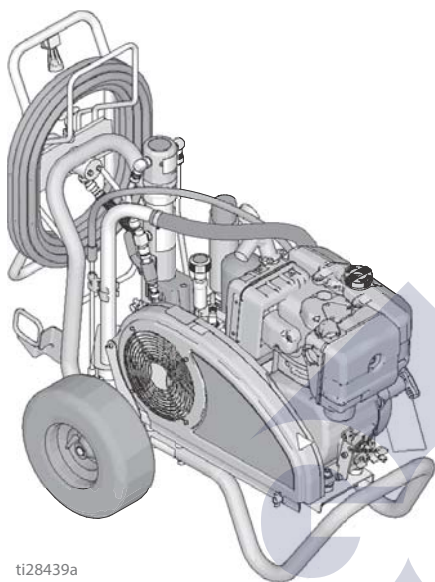

ti28439a

DH230

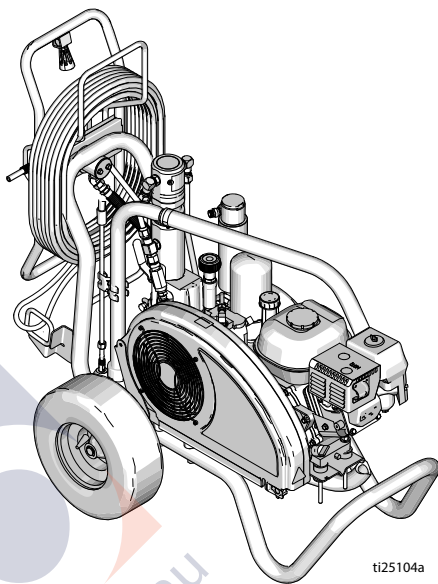







ti25104a

GH™200/230/300

goind.com.au

Parts

DH230/GH™200/230/300 ProContractor Series

Ref.	Torque	Ref.	Torque
 1	120-130 in-lb (13.6 - 14.7 N•m)	 4	355-395 in-lb (40.1 - 44.6 N•m)
 2	Inflate tires to 25-35 psi (1.7-2.4 bar)	 5	15-25 in-lb (1.7 - 2.8 N•m)
 3	110-120 in-lb (12.4 - 13.6 N•m)	 6	Apply Locktite 242

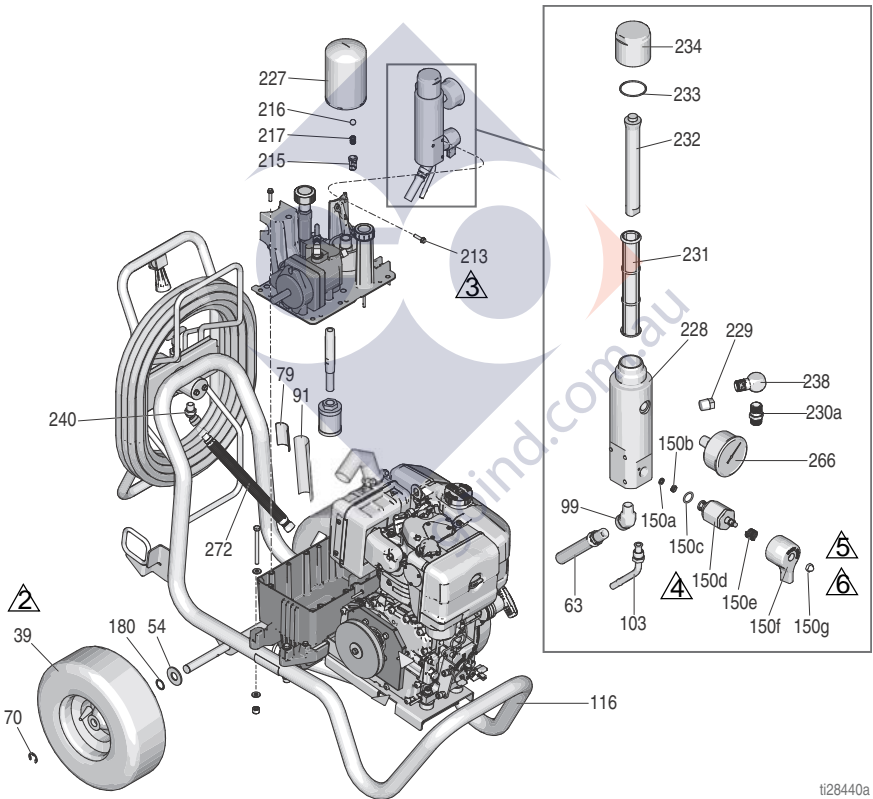



ti28440a

DH230/GH™200/230/300 ProContractor

Parts List

Ref.	Part	Description	Qty.	Ref.	Part	Description	Qty.
39	119509	WHEEL, pneumatic	2	215	198841	RETAINER	1
54	156306	WASHER, flat	2	216	100084	BALL, metallic	1
63	243814	HOSE	1	217	116967	SPRING, compression	1
70	120211	CLIP, retaining	2	227	246173	FILTER, oil, spin on	1
79▲	189246	LABEL, warning	1	228‡	15E599	HOUSING	1
	17D947	LABEL, warning, multi-languages	1	229‡	15G331	PLUG, pipe	1
91▲	194317	LABEL, warning	1	230a	196178	ADAPTER 3/8 npsm (m) hose connection	1
	16N948	LABEL, warning, ISO	1	231‡	244067	FILTER, fluid	1
	17D947	LABEL, warning, multi-languages	1	232‡	15C766	TUBE, diffusion	1
99	116756	FITTING, elbow 45°	1	233‡	117285	PACKING, o-ring	1
116	17D106	FRAME, cart	1	234‡	15C765	CAP, filter	1
150‡	245103	VALVE, drain	1	238	196179	FITTING, elbow, street	1
150a★	193710	SEAL, valve	1	240	161889	UNION, swivel, 45°	1
150b★	193709	SEAT, valve	1	266	868015	GAUGE	1
150c★	114797	GASKET	1	272	198847	HOSE, coupled	1
150d★	VALVE, assembly	1	▲ <i>Danger and Warning labels are available at no cost.</i>				
150e★	114708	SPRING, compression					1
150f★	15G563	HANDLE, valve	1	★ <i>Included in Drain Valve Replacement Kit 245103</i>			
150g★	116424	NUT, cap, hex hd	1				
180	116038	WASHER, wave spring	2	‡ <i>Included in Filter Replacement Kit 24W753</i>			
213	119426	SCREW	3				

Parts - Engines

Ref.	Torque	Ref.	Torque
	120-130 in-lb (13.6 - 14.7 N•m)		Apply Loctite 242
	58-62 in-lb (6.6 - 7.0 N•m)		

GH™200230 ProContractor Series

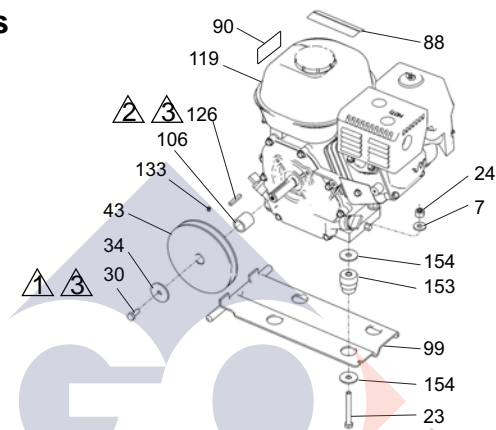

GH™300 ProContractor Series

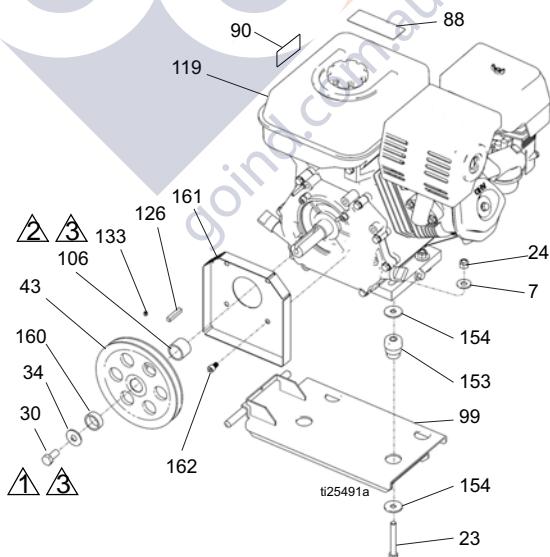

DH230/GH™200/230/300 ProContractor

Parts - Engines

DH230 ProContractor Series

Ref.	Torque	Ref.	Torque
⚠1	120-130 in-lb (13.6 - 14.7 N•m)	⚠3	Apply Loctite 242
⚠2	58-62 in-lb (6.6 - 7.0 N•m)	⚠4	65-85 in-lb (7.3 - 9.6 N•m)

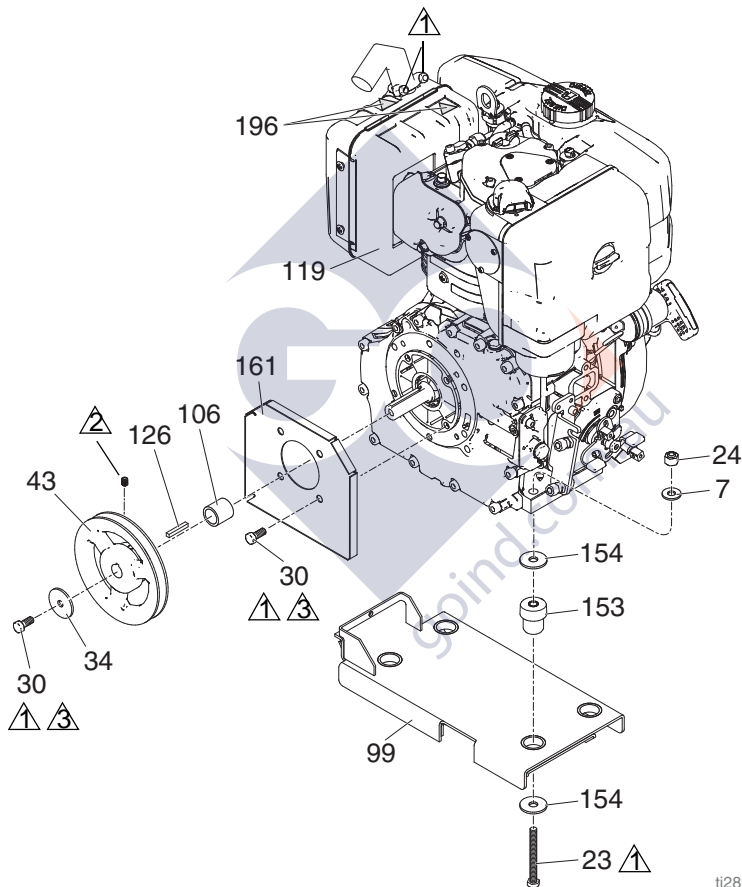

ti28390a

Engine Parts List

Ref.	Part	Description	Qty.	Ref.	Part	Description	Qty.
				119*	802264	ENGINE, gasoline, 160 cc, GH200	1
7	100023	WASHER, flat, DH230, GH200 & 230	4		116298	ENGINE, gasoline, 200 cc, Honda, GH230	1
	100132	WASHER, flat, GH300	4		803900	ENGINE, gasoline, 270 cc, Honda, GH300	1
23	113664	SCREW, cap, hex hd, GH200 & 230	4		17H150	ENGINE, Diesel, 350 cc, Kohler, DH230	1
	106212	SCREW, cap, hex hd, GH300	4	126	117632	KEY, square, 3/16 X 1.25, GH130, 200 & 230	1
	110385	SCREW, cap, hex hd, DH230	4		17L826	KEY, square, 3/16 X 1.125, DH230	1
24	110838	NUT, lock, DH230, GH200 & 230	4		119484	KEY, parallel, square, GH300	1
	101566	NUT, lock, GH300	4	133	100002	SCREW, set, sch	1
30		SCREW, cap, hex hd GH200 & 230		153	15E888	DAMPENER, motor mount, DH230, GH200 & 230	4
	108842	DH230	1		195515	DAMPENER, motor mount, GH300	4
	108842	DH230	5				
	116645	GH300	1	154	108851	WASHER, plain	8
34	112717	WASHER, GH200 & 230	1	160	15E764	SPACER, GH300	1
	119438	WASHER, GH300	1	161		SHIELD	
43	116908	PULLEY, 5.50 in, GH200 & 230	1		15E973	GH300	1
	17L825	PULLEY, 6 in, DH230	1		17K215	DH230	1
	119401	PULLEY, GH300	1	162	C20010	SCREW, GH300	4
88▲	194126	LABEL, warning	1	196▲	17K859	LABEL, safety, hot surface	2
	16Y631	LABEL, warning, Chinese	1				
90▲	16Y720	LABEL, warning, ISO	1				
		engine					
99	15F157	BRACKET, mounting, engine, GH200 & 230	1				
	15E583	BRACKET, mounting, engine, GH300	1				
	17H148	BRACKET, mounting, engine, DH230	1				
106	15B314	SLEEVE, motor shaft, GH200 & 230	1				
	15E586	SLEEVE, motor shaft, GH300	1				
	17L823	SLEEVE, motor shaft, DH230	1				







▲ Danger and Warning labels are available at no cost.

*Engine Repair Kits:

248943	160 cc (5.5 HP)
248944	200 cc (6.5 HP)
248945	270 cc (9.0 HP)

Parts - Fan Belt

DH230/GH™200/230/300 ProContractor Series

Ref.	Torque	Ref.	Torque
	120-130 in-lb (13.6 - 14.7 N•m)		90-110 in-lb (10.2 - 12.4 N•m)
	Apply Locktite 242		Apply Locktite 277
	55-62 in-lb (6.7 - 7.0 N•m)		110-120 in-lb (12.4 - 13.6 N•m)

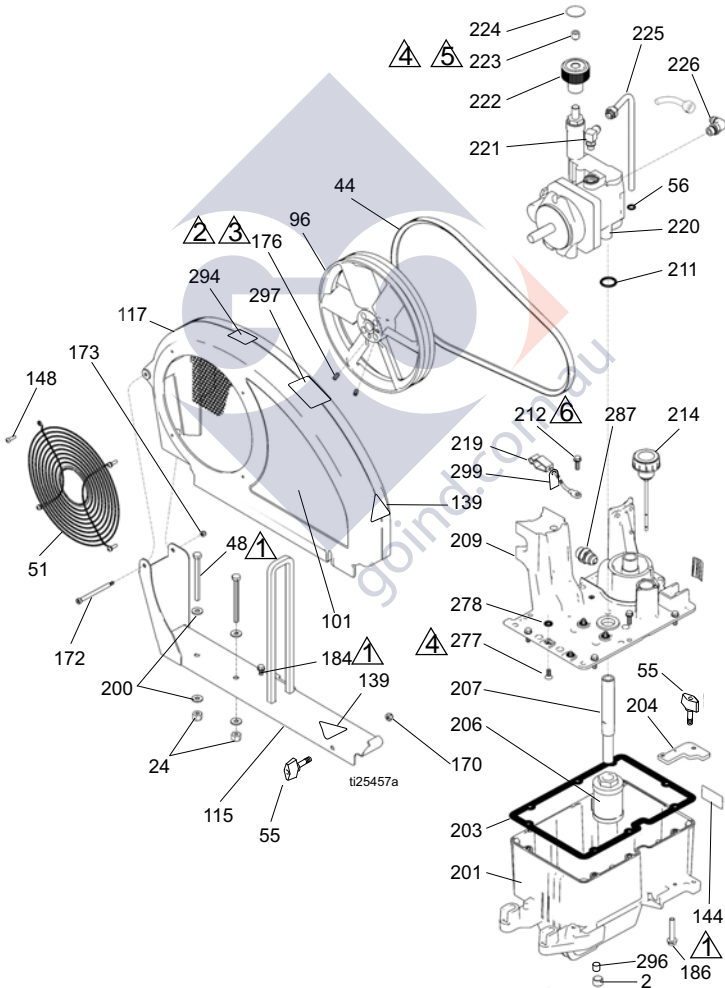

DH230/GH™200/230/300 ProContractor

Parts List

Ref.	Part	Description	Qty.	Ref.	Part	Description	Qty.
2	101754	PLUG	1	203	120604	GASKET, reservoir	1
24	110838	NUT, lock	2	204	15E476	BRACKET, retainer, motor	1
44	119433	BELT, GH200, 230	1	206	116919	FILTER	1
	119432	BELT, GH300	1	207	15E587	TUBE, suction	1
	17L829	BELT, DH230	1	208	154594	PACKING, o-ring	1
48	867539	SCREW, hex head	2	209	15J363	COVER, reservoir	1
51	117284	GRILL, fan guard	1	211	156401	PACKING, o-ring	1
55	17D813	NUT, hand	2	212	119426	SCREW	8
56	154594	O-RING	1	214	120726	CAP, breather, filler	1
96	15E410	PULLEY, fan	1		17L080	CAP, breather, filter	1
101	17D032	LABEL, GH200	1			(DH230)	
	17D034	LABEL, GH230	1	219	237686	WIRE, ground with clamp	1
	17D036	LABEL, GH300	1	220	246178	PUMP, hydraulic, DH230, GH200	
	17J336	LABEL, DH230	1		249003	PUMP, hydraulic, 230/300	
115	288261	RAIL, belt guard, assembly, GH200	1	221	110792	FITTING, elbow, male, 90°	1
	288393	RAIL, belt guard, assembly, DH230, GH230 & 300	1	222	15B438	KNOB, pressure	1
				223	117560	SCREW, set, socket head	1
117	288734	GUARD, belt assembly, painted, GH200	1	224	15A464	LABEL, control	1
	248973	GUARD, belt, assembly, painted, DH230, GH230 & 300	1	225	246167	TUBE, hydraulic, case drain	1
				226	116829	FITTING, elbow, with o-rings	1
139▲	16M768	LABEL, safety, warning	2	277	117471	SCREW	4
144	15K440	LABEL, GH/EH, cooling system	1	278	107188	PACKING, o-rings	4
148	115477	SCREW, mach, torx pan hd	4	284	16P142	LABEL, hydraulic fluid, GH	1
170	102040	NUT, lock, hex	1	287	120184	FITTING	1
172	119434	SCREW, shoulder, socket head	1	294	16D576	LABEL, made in USA	1
				296	116618	MAGNET	1
173	116969	NUT, lock	1	297	17D033	LABEL, ProContractor series	1
176	120087	SCREW, set, 1/4 X 1/2	2	299	290079	LABEL, ground warning, English	1
184	260212	SCREW, hex washer hd, thd form	1		16Y633	LABEL, ground warning, Chinese	1
186	17D142	SCREW, mach, hex washer head	2				
200	100527	WASHER	4				
201	15J513	TANK, reservoir	1				
202	101754	PLUG, pipe	1				

▲ Danger and Warning labels are available at no cost.

Parts

DH230/GH™200/230/300 ProContractor Series

Ref.	Torque
	90-110 in-lb (10.2 - 12.4 N•m)

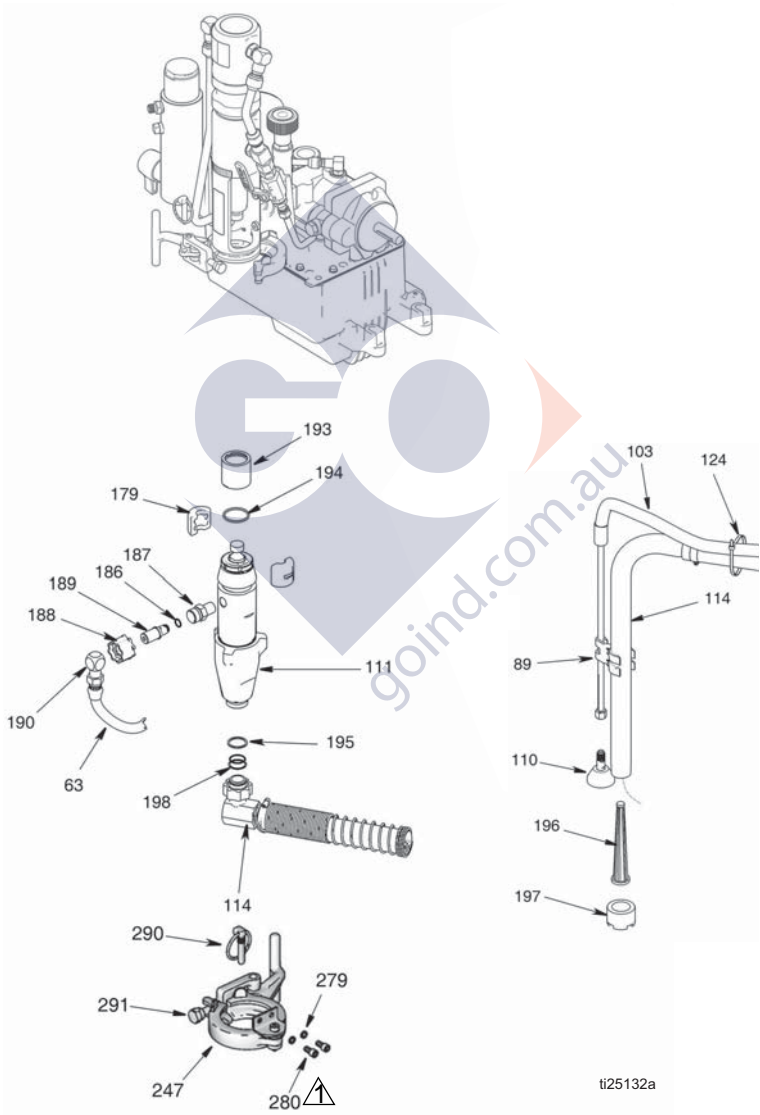

ti25132a

DH230/GH™200/230/300 ProContractor

Parts List

Ref.	Part	Description	Qty.	Ref.	Part	Description	Qty.
63	243814	HOSE, coupled	1	194	156698	PACKING, o-ring	1
111	24W996	PUMP, kit, displacement, GH200	1	195	119566	WASHER, garden hose	1
	24W998	PUMP, kit, displacement, DH230, GH230 & 300	1	196*	288472	INLET FILTER, 10 mesh	1
114	288252	HOSE, suction, 5 gallon, GH200, 230 & 300	1		289131	INLET FILTER, 16 mesh	1
115	289669	HOSE, suction, 30/55 gallon, DH230, GH200/230/300 (not shown)	1	197*	288480	NUT, strainer, inlet	1
				198	117559	O-RING	2
179	277377	COUPLER	2	247	288344	CLAMP, pump; DH230, GH 200, 230, 300	1
186	107505	PACKING, o-ring	1	279	105510	WASHER, lock, spring (hi-collar), DH230, GH200, GH230, GH300	2
187	15J413	FITTING, pump, QD	1	280	101550	SCREW, cap, sch	2
188	120583	NUT, hand, DH230, GH200/230/300	1	290	288741	KIT, repair, pin/spacer; DH230, GH 200, 230, 300	1
189	15J410	FITTING, QD	1	291	15J417	BOLT, adjustment; DH230, GH 200, 230, 300	1
190	196179	FITTING, elbow, street, sprayer	1			* Included in Accessory Kit 288481 (10 mesh) or Accessory Kit 289132 (16 mesh)	
193	15H957	COVER, coupler	1				



Parts

DH230/GH™200/230/300 ProContractor Series

Ref.	Torque	Ref.	Torque
	145-155 ft-lb (196.6 - 210.2 N•m)		140-160 in-lb (15.8 - 18.1 N•m)
	12-18 ft-lb (16.3 - 24.4 N•m)		

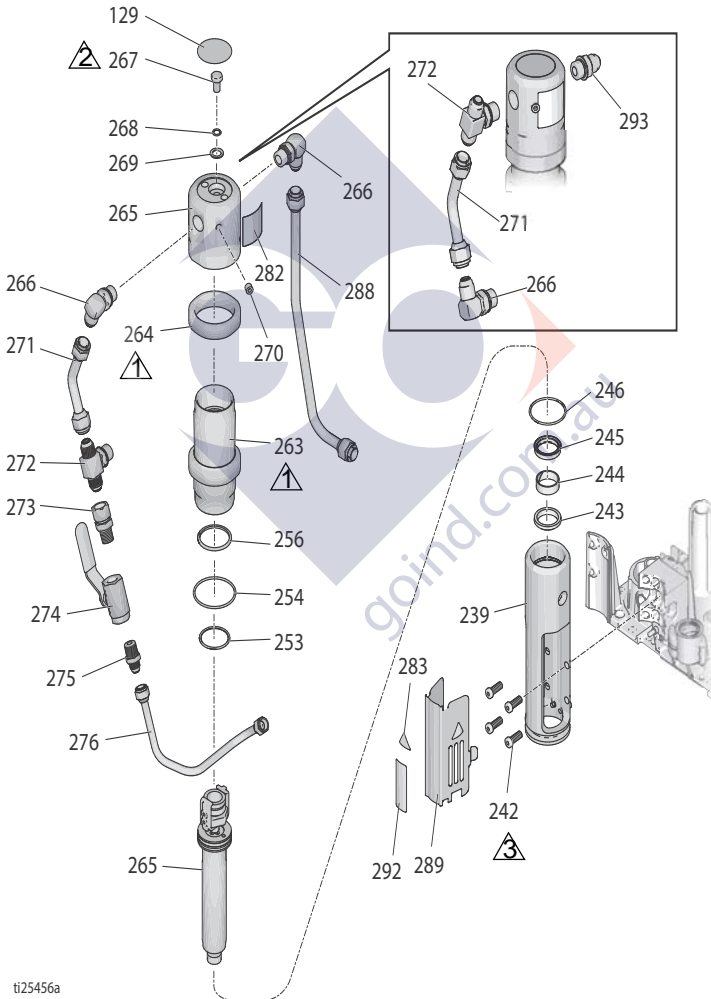

DH230/GH™200/230/300 ProContractor

Parts List

Ref.	Part	Description	Qty.	Ref.	Part	Description	Qty.
129▲◆✓	15B063	LABEL, warning, hot surface	1		15E596	TUBE, hydraulic, supply, DH230, GH230 & 300	1
143▲	17D051	LABEL, GH200	1	272◆	117609	FITTING, tee, branch, str thd	1
	17D053	LABEL, GH230	1		117328	FITTING, nipple, straight	1
	17D055	LABEL, GH300	1	273	117441	VALVE, ball	1
	17J337	LABEL, DH230	1	275	116813	FITTING, nipple, hydraulic	1
239◆	15J278	MANIFOLD, GH200	1	276	15J846	TUBE, hydraulic, supply, GH200	1
	15J279	MANIFOLD, DH230, GH230 & 300	1		15J864	TUBE, hydraulic, supply, DH230, GH230, GH300	1
242◆	15B564	SCREW, cap socket	4	282▲✓	15B804	LABEL, Graco logo	1
243‡◆	117739	WIPER, rod	1	283▲◆	15H108	LABEL, warning	2
244‡	112342	BEARING, rod	1	288	15J845	TUBE, hydraulic, return, GH200	1
245‡◆	112561	PACKING, block	1		15J863	TUBE, hydraulic, return, DH230, GH230 & 300	1
246‡◆	117283	PACKING, o-ring	2	289	15J503	SHIELD, rod, GH200	1
253‡◆✓	108014	PACKING, o-ring	1		16M749	SHIELD, rod, DH230, GH230 & 300	1
254‡◆✓	178226	SEAL, piston	1	292◆	15F584	LABEL, ProConnect	1
256‡◆✓	178207	BEARING, piston	1	293	120184	FITTING, straight, OEM kits only	1
263◆	246176	SLEEVE, hydraulic cylinder, kit, GH200	1				
	248991	SLEEVE, hydraulic cylinder, kit, DH230, GH230 & 300)	1				
264◆	15A726	NUT, jam	1				
265◆	288736	KIT, repair, trip rod, piston; GH 200 only	1				
	288737	KIT, repair, trip rod, piston; DH230, GH 230/300 only	1				
266◆	117607	FITTING, elbow std thd	2				
267✓◆	106276	SCREW, cap, hex head	1				
268✓◆	155685	PACKING, o-ring	1				
269✓◆	178179	WASHER, sealing	1				
270✓◆	100139	PLUG, pipe	1				
271◆	198629	TUBE, hydraulic, supply, GH200	1				

▲ Danger and Warning labels are available at no cost.

◆ Included in Hydraulic Motor Repair Kit: 288759 - GH200; 288760 - DH230, GH230 & 300

✓ Included in Trip Rod/Piston Kit: 288736 - GH200; 288737 - DH230, GH230 & 300

‡ Included in Seal Kit 246174

Parts

GH™200 ProContractor Series Spray Gun and Hoses (Assembled on Hose Reel)

Ref.	Part No.	Description	Qty.
202	240794	HOSE, grounded, nylon; 1/4 in. ID; cpld 1/4-18 npsm; 50 foot (15 m); spring guards both ends 3300 psi (227 bar, 22.7 MPa)	2
203	288420	Contractor Spray Gun Includes 517 RAC® X SwitchTip and HandTite™ Guard See 311861 for parts	1
204	162453	ADAPTER	1

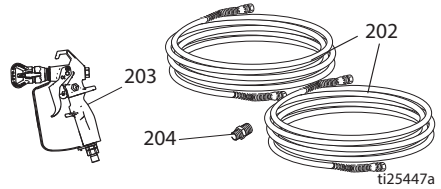

DH230/GH™230 ProContractor Series Spray Gun and Hoses (Assembled on Hose Reel)

Ref.	Part No.	Description	Qty.
301	240794	HOSE, grounded, nylon; 1/4 in. ID; cpld 1/4-18 npsm; 50 foot (15 m); spring guards both ends 3300 psi (227 bar, 22.7 MPa)	1
302	240797	HOSE, grounded, nylon; 3/8 in. ID; cpld 3/8-18 npsm; 50 foot (15 m); spring guards both ends 3300 psi (227 bar, 22.7 MPa)	1
304	246240	Silver Spray Gun Includes 517 RAC® X SwitchTip and HandTite™ Guard See 311254 for parts	1
306	164672	3/8 x 1/4 adapter	1
309	239663	SWIVEL	1



DH230/GH™200/230/300 ProContractor

GH™ 300 ProContractor Series Spray Gun and Hoses (Assembled on Hose Reel)

Ref.	Part No.	Description	Qty.
302	240797	HOSE, grounded, nylon; 3/8 in. ID; cpld 3/8-18 npsm; 50 foot (15 m); spring guards both ends 3300 psi (227 bar, 22.7 MPa)	1
303	241735	HOSE, grounded, nylon; 1/4 in. ID; cpld 1/4 npt(m) x 1/4 npsm(f); 3 foot (0.9 m); spring guards both ends 3300 psi (227 bar, 22.7 MPa)	1
304	246240	Silver Spray Gun Includes 517 RAC® X SwitchTip and HandTite™ Guard See 311254 for parts	1
307	162485	3/8 x 3/8 nipple	1
308	159841	3/8 x 1/4 bushing	1
309	239663	SWIVEL	1

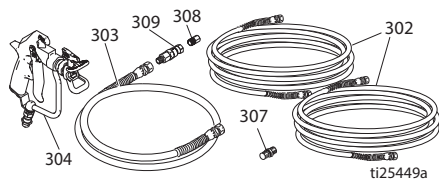

Hose Reel (ProContractor Series)

Ref.	Part	Description	Qty.
6	161889	FITTING, connector	1
8	260212	SCREW, hex washer hd	2
9	16C975	PLATE, pivot mount	1
201	24E016	SEAL, fitting, flared	1
203	122607	WASHER, flat	2
204	122534	SPRING, wave	1
205	24B691	REEL, hose	1
206	122524	RING, retaining, external	1
208	24B248	CAP, swivel, complete	1
209	122347	RING, retaining, external	1
210	122787	CAP	1
211	24E400	PIN, pop, lock out	1
212	278085	HANDLE, swivel	1
213	122518	SCREW, shoulder, sch	1
214	122542	SPRING, die	1
215	122669	WASHER, flat	1
216	15X618	NUT, swivel, handle	1
221	164672	ADAPTER, GH200	1
196178	ADAPTER, DH230/GH230/300		1

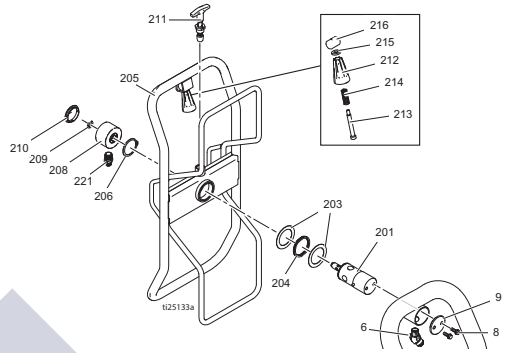

Torque to 120-130 in-lbs (13.6-14.7 N·m)

Torque to 25-35 ft-lbs (33.9-47.5 N·m)

Torque to 130-150 in-lbs (14.7-16.9 N·m)

Loctite 277

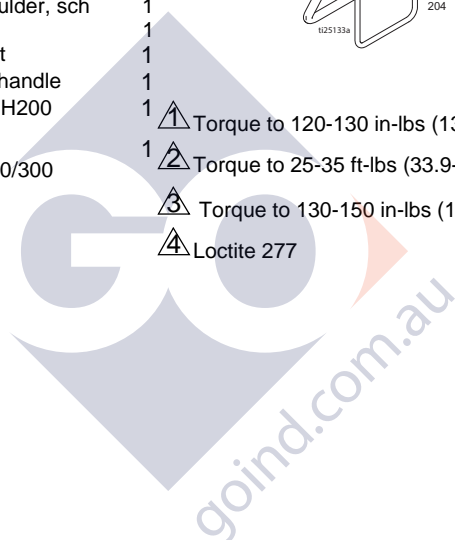

Technical Data

GH™130 Standard Series		
	US	Metric
Maximum fluid working pressure	3300 psi	22.8 MPa, 228 bar
Hydraulic reservoir capacity	1.25 gallons	4.75 liters
Maximum hydraulic pressure	1510 psi	10.4 MPa, 104 bar
Engine	120 cc (4.0 HP)	
Maximum tip size	0.037	
Maximum free-flow delivery	1.30 gpm	5.9 l/min
Hose connection	1/4 npsm (m)	
Noise (dBa)		
Maximum sound pressure	88 dBa	
Maximum sound power	103 dBa	
Inlet/Outlet Sizes		
Fluid inlet size	3/4 npt (m)	
Fluid outlet size	3/8 npt (f)	
Dimensions		
Weight	155 lb.	70.3 kg
Width	24 in.	61 cm
Length	41 in.	104.1 cm
Height (Handle extended)	39.5 in.	100.3 cm
Height (Handle retracted)	30.3 in.	77.0 cm
OEM Kit		
Paint/Hydraulic pressure ratio	2.19:1	
Max cycle rate	125 cpm	
User Supplied Input		
Max hydraulic pressure	1510 psi	10.4 MPa, 104 bar
Hydraulic flow required in free-flow	4.01 gpm	15.2 l/min
Unit Output		
Max fluid Pressure	3300 psi	22.8 MPa, 228 bar
Max flow	1.30 gpm	4.92 l/min
Weight	27.5 lb.	12.5 kg
Width	5.70 in.	145 mm
Depth	3.14 in.	80 mm
Height	25.4 in.	645 mm

Technical Data

GH™ 200 Standard Series

	US	Metric
Maximum fluid working pressure	3300 psi	22.8 MPa, 228 bar
Hydraulic reservoir capacity	1.25 gallons	4.75 liters
Maximum hydraulic pressure	1855 psi	12.8 MPa, 128 bar
Engine	160 cc (5.5 HP)	
Maximum tip size	0.047	
Maximum free-flow delivery	2.15 gpm	9.8 l/min
Hose connection	1/4 npsm (m)	
Noise (dBa)		
Maximum sound pressure	96 dBa	
Maximum sound power	110 dBa	
Inlet/Outlet Sizes		
Fluid inlet size	1 5/16-12 UN-ZA	
Fluid outlet size	3/8 npt (f)	
Weight	160 lb.	73.4 kg
Width	24 in.	61 cm
Length	41 in.	104.1 cm
Height (Handle extended)	39.5 in.	100.3 cm

GH™ 230 Standard Series

	US	Metric
Maximum fluid working pressure	3300 psi	22.8 MPa, 228 bar
Hydraulic reservoir capacity	1.25 gallons	4.75 liters
Maximum hydraulic pressure	1855 psi	12.8 MPa, 128 bar
Engine	200 cc (6.5 HP)	
Maximum tip size	0.053	
Maximum free-flow delivery	2.35 gpm	10.7 l/min
Hose connection	3/8 npsm (m)	
Noise (dBa)		
Maximum sound pressure	96 dBa	
Maximum sound power	110 dBa	
Inlet/Outlet Sizes		
Fluid inlet size	1 5/16-12 UN-ZA	
Fluid outlet size	3/8 npt (f)	
Weight	168 lb.	75.6 kg
Width	24 in.	61 cm
Length	48 in.	121.92 cm
Height (Handle extended)	41.0 in.	104.1 cm
Height (Handle retracted)	33.0 in.	83.8 cm

GH™ 300 Standard Series

	US	Metric
Maximum fluid working pressure	3300 psi	22.8 MPa, 228 bar
Hydraulic reservoir capacity	1.25 gallons	4.75 liters
Maximum hydraulic pressure	1855 psi	12.8 MPa, 128 bar
Engine	270 cc (9.0 HP)	
Maximum tip size	0.057	
Maximum free-flow delivery	3.0 gpm	11.4 l/min
Hose connection	3/8 npsm (m)	
Noise (dBa)		
Maximum sound pressure	96 dBa	
Maximum sound power	110 dBa	
Inlet/Outlet Sizes		
Fluid inlet size	1 5/16-12 UN-ZA	
Fluid outlet size	3/8 npt (f)	
Weight	195 lb.	87.8 kg
Width	24 in.	61 cm
Length	48 in.	121.92 cm
Height (Handle extended)	41.0 in.	104.1 cm
Height (Handle retracted)	33.0 in.	83.8 cm

goind.com.au

Technical Data

GH™ 200 ProContractor Series

	US	Metric
Maximum fluid working pressure	3300 psi	22.8 MPa, 228 bar
Hydraulic reservoir capacity	1.25 gallons	4.75 liters
Maximum hydraulic pressure	1855 psi	12.8 MPa, 128 bar
Engine	160 cc (5.5 HP)	
Maximum tip size	0.047	
Maximum free-flow delivery	2.15 gpm	9.8 l/min
Hose connection	1/4 npsm (m)	
Noise (dBa)		
Maximum sound pressure	96 dBa	
Maximum sound power	110 dBa	
Inlet/Outlet Sizes		
Fluid inlet size	1 5/16-12 UN-ZA	
Fluid outlet size	3/8 npt (f)	
Weight	188 lb.	85.3 kg
Width	25.3 in.	64.3 cm
Length	44.8 in.	113.8 cm
Height (Hose Reel Up)	38.5 in.	97.8 cm
Pump Height (Hose Reel Sideways)	31.0 in.	78.7 cm
OEM Kit		
Paint/Hydraulic pressure ratio	1.78:1	
Max cycle rate	160 cpm	
User Supplied Input		
Max hydraulic pressure	1855 psi	12.8 MPa, 128 bar
Hydraulic flow required in free-flow	5.13 gpm	19.4 l/min
Unit Output		
Max fluid Pressure	3300 psi	22.8 MPa, 228 bar
Max flow	2.15 gpm	8.14 l/min
Weight	32.5 lb.	14.7 kg
Width	5.39 in.	137 mm
Depth	5.39 in.	137 mm
Height	25.60 in.	650 mm

DH230/GH™230 ProContractor Series

	US	Metric
Maximum fluid working pressure	3300 psi	22.8 MPa, 228 bar
Hydraulic reservoir capacity	1.25 gallons	4.75 liters
Maximum hydraulic pressure	1855 psi	12.8 MPa, 128 bar
Engine		
DH230	350 cc (6.7 HP)	
GH230	200 cc (6.5 HP)	
Maximum tip size	0.053	
Maximum free-flow delivery	2.35 gpm	10.7 l/min
Hose connection	3/8 npsm (m)	
Noise (dBa)		
Maximum sound pressure		
DH230	91 dBa	
GH230	96 dBa	
Maximum sound power		
DH230	106 dBa	
GH230	110 dBa	
Inlet/Outlet Sizes		
Fluid inlet size	1 5/16-12 UN-ZA	
Fluid outlet size	3/8 npt (f)	
Weight		
DH230	230 lb.	104.2 kg
GH230	193 lb.	87.5 kg
Width	25.3 in.	64.3 cm
Length	44.8 in.	113.8 cm
Height (Hose Reel Up)	38.5 in.	97.8 cm
Pump Height (Hose Reel Sideways)	33.0 in.	83.8 cm
OEM Kit		
Paint/Hydraulic pressure ratio	1.78:1	
Max cycle rate	145 cpm	
User Supplied Input		
Max hydraulic pressure	1855 psi	12.8 MPa, 128 bar
Hydraulic flow required in free-flow	6.60 gpm	25.0 l/min
Unit Output		
Max fluid Pressure	3300 psi	22.8 MPa, 228 bar
Max flow	3.0 gpm	11.4 l/min
Weight	35 lb.	15.9 kg
Width	8.94 in.	227 mm
Depth	5.38 in.	137 mm
Height	28.80 in.	732 mm

Technical Data

GH™ 300 ProContractor Series

	US	Metric
Maximum fluid working pressure	3300 psi	22.8 MPa, 228 bar
Hydraulic reservoir capacity	1.25 gallons	4.75 liters
Maximum hydraulic pressure	1855 psi	12.8 MPa, 128 bar
Engine	270 cc (9.0 HP)	
Maximum tip size	0.057	
Maximum free-flow delivery	3.0 gpm	11.4 l/min
Hose connection	3/8 npsm (m)	
Noise (dBa)		
Maximum sound pressure	96 dBa	
Maximum sound power	110 dBa	
Inlet/Outlet Sizes		
Fluid inlet size	1 5/16-12 UN-ZA	
Fluid outlet size	3/8 npt (f)	
Weight	222 lb.	100.7 kg
Width	25.3 in.	64.3 cm
Length	44.8 in.	113.8 cm
Height (Hose Reel Up)	38.5 in.	97.8 cm
Pump Height (Hose Reel Sideways)	33.0 in.	83.8 cm
OEM Kit		
Paint/Hydraulic pressure ratio	1.78:1	
Max cycle rate	145 cpm	
User Supplied Input		
Max hydraulic pressure	1855 psi	12.8 MPa, 128 bar
Hydraulic flow required in free-flow	6.60 gpm	25.0 l/min
Unit Output		
Max fluid Pressure	3300 psi	22.8 MPa, 228 bar
Max flow	3.0 gpm	11.4 l/min
Weight	35 lb.	15.9 kg
Width	8.94 in.	227 mm
Depth	5.38 in.	137 mm
Height	28.80 in.	732 mm

All Models:

Basic Sprayer Wetted Parts:

Zinc and nickel-plated carbon steel, stainless steel, PTFE, acetal, chrome plating, leather, V-Maxt UHMWPE, stainless steel, tungsten carbide, ceramic, nylon, aluminum

GH130 OEM

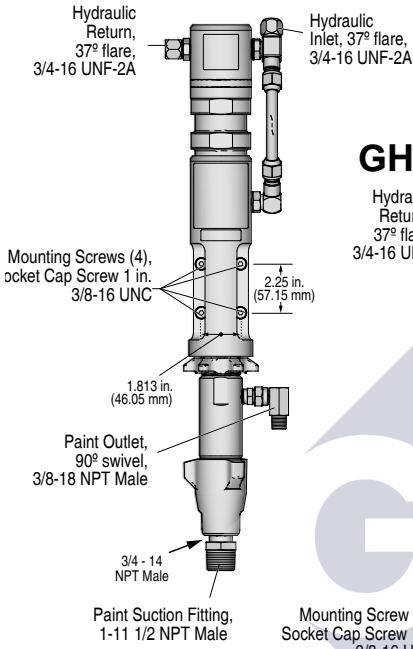

GH200 OEM

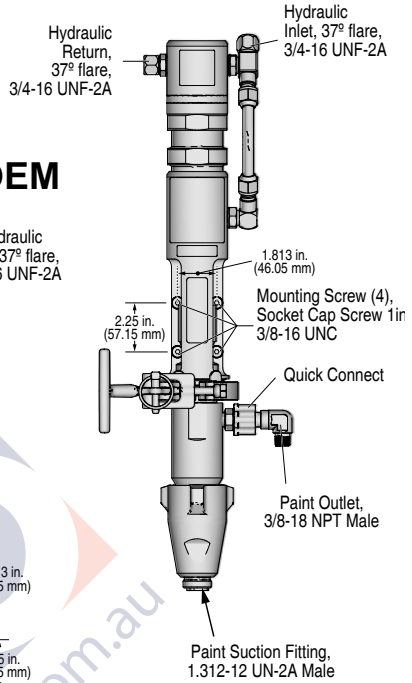

GH230/300 OEM

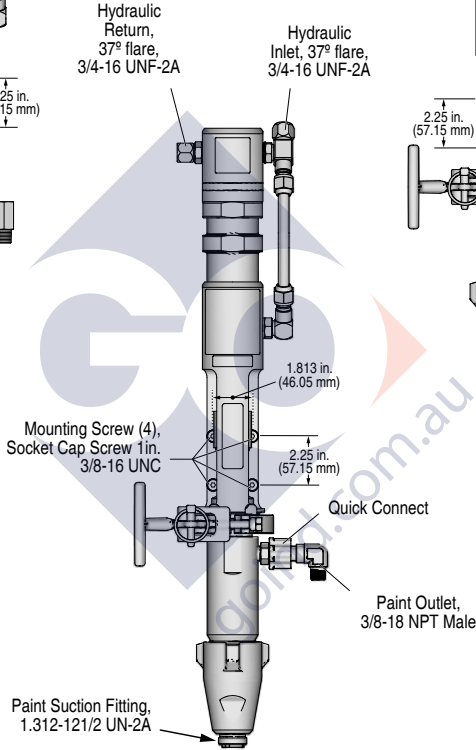

024313b

Graco Standard Warranty

Graco Standard Warranty

Graco warrants all equipment referenced in this document which is manufactured by Graco and bearing its name to be free from defects in material and workmanship on the date of sale to the original purchaser for use. With the exception of any special, extended, or limited warranty published by Graco, Graco will, for a period of twelve months from the date of sale, repair or replace any part of the equipment determined by Graco to be defective. This warranty applies only when the equipment is installed, operated and maintained in accordance with Graco's written recommendations.

This warranty does not cover, and Graco shall not be liable for general wear and tear, or any malfunction, damage or wear caused by faulty installation, misapplication, abrasion, corrosion, inadequate or improper maintenance, negligence, accident, tampering, or substitution of non-Graco component parts. Nor shall Graco be liable for malfunction, damage or wear caused by the incompatibility of Graco equipment with structures, accessories, equipment or materials not supplied by Graco, or the improper design, manufacture, installation, operation or maintenance of structures, accessories, equipment or materials not supplied by Graco.

This warranty is conditioned upon the prepaid return of the equipment claimed to be defective to an authorized Graco distributor for verification of the claimed defect. If the claimed defect is verified, Graco will repair or replace free of charge any defective parts. The equipment will be returned to the original purchaser transportation prepaid. If inspection of the equipment does not disclose any defect in material or workmanship, repairs will be made at a reasonable charge, which charges may include the costs of parts, labor, and transportation.

THIS WARRANTY IS EXCLUSIVE, AND IS IN LIEU OF ANY OTHER WARRANTIES, EXPRESS OR IMPLIED, INCLUDING BUT NOT LIMITED TO WARRANTY OF MERCHANTABILITY OR WARRANTY OF FITNESS FOR A PARTICULAR PURPOSE.

Graco's sole obligation and buyer's sole remedy for any breach of warranty shall be as set forth above. The buyer agrees that no other remedy (including, but not limited to, incidental or consequential damages for lost profits, lost sales, injury to person or property, or any other incidental or consequential loss) shall be available. Any action for breach of warranty must be brought within two (2) years of the date of sale.

GRACO MAKES NO WARRANTY, AND DISCLAIMS ALL IMPLIED WARRANTIES OF MERCHANTABILITY AND FITNESS FOR A PARTICULAR PURPOSE, IN CONNECTION WITH ACCESSORIES, EQUIPMENT, MATERIALS OR COMPONENTS SOLD BUT NOT MANUFACTURED BY GRACO. These items sold, but not manufactured by Graco (such as electric motors, switches, hose, etc.), are subject to the warranty, if any, of their manufacturer. Graco will provide purchaser with reasonable assistance in making any claim for breach of these warranties.

In no event will Graco be liable for indirect, incidental, special or consequential damages resulting from Graco supplying equipment hereunder, or the furnishing, performance, or use of any products or other goods sold hereto, whether due to a breach of contract, breach of warranty, the negligence of Graco, or otherwise.

FOR GRACO CANADA CUSTOMERS

The Parties acknowledge that they have required that the present document, as well as all documents, notices and legal proceedings entered into, given or instituted pursuant hereto or relating directly or indirectly hereto, be drawn up in English. Les parties reconnaissent avoir convenu que la rédaction du présente document sera en Anglais, ainsi que tous documents, avis et procédures judiciaires exécutés, donnés ou intentés, à la suite de ou en rapport, directement ou indirectement, avec les procédures concernées.

Graco Information

For the latest information about Graco products, visit www.graco.com.

For patent information, see www.graco.com/patents.

TO PLACE AN ORDER, contact your Graco distributor or call 1-800-690-2894 to identify the nearest distributor.



All written and visual data contained in this document reflects the latest product information available at the time of publication.

Graco reserves the right to make changes at any time without notice.

Original instructions. This manual contains English. MM 334558

Graco Headquarters: Minneapolis

International Offices: Belgium, China, Japan, Korea

GRACO INC. AND SUBSIDIARIES • P.O. BOX 1441 • MINNEAPOLIS MN 55440-1441 • USA

Copyright 2015, Graco Inc. All Graco manufacturing locations are registered to ISO 9001.

www.graco.com

Revision D, April 2016