

Merkur[®] High Pressure Displacement Pump

332246C

EN

**High pressure carbon steel pump for protective coatings.
For professional use only.**

See page 2 for model information, including maximum working pressures.



Important Safety Instructions

Read all warnings and instructions in this manual. For complete warnings and instructions see your sprayer manual. Hazard symbols refer to specific procedure risks. Save all instructions.

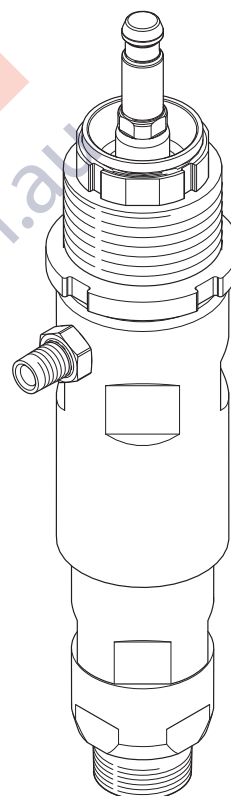

ti21064a

Contents

Related Manuals 2

Component Identification 3

Repair 4

 Preparation 4

 Disassembly 4

 Reassembly 5

Parts 8

Repair Kits 10

Accessories 10

Dimensions 11

Technical Data 12

Graco Standard Warranty 14

Related Manuals

Manual	Description
312796	NXT™ Air Motor
332245	Merkur High Pressure Sprayers
407053	Merkur X48 Rebuild Kit
407054	Merkur X72 Rebuild Kit

Models

Check your displacement pump’s identification marking for the 6-digit part number. Displacement pumps use a Chromex coated rod, 3 UHM-WPE, and 2 PTFE packings.

To order replacement parts, see **Parts** section starting on page 8.

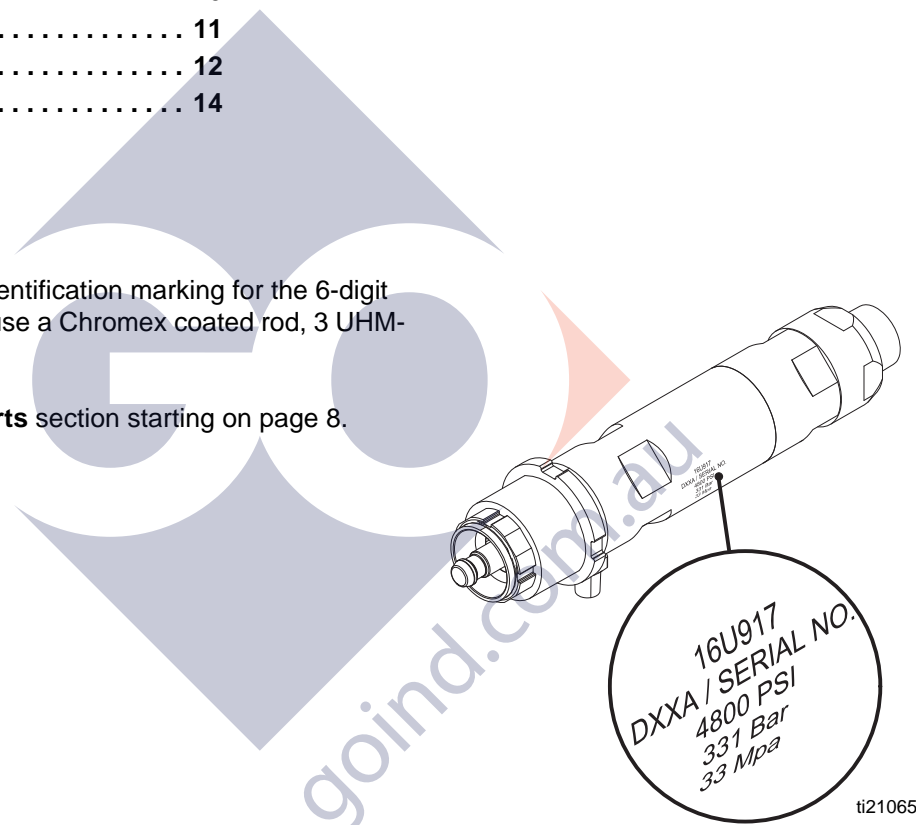

ti21065a

Model, Series	Description	Maximum Working Pressure psi (MPa, bar)	Displacement Pump Volume Per Cycle* in cc	Fluid Inlet	Fluid Outlet
16U917, Series A	Merkur X48 Pump	4800 (33, 330)	75	1-1/4 in. npt	3/8 in. npt
16U916, Series A	Merkur X72 Pump	7200 (50, 500)	50	1-1/4 in. npt	3/8 in. npt

* Cycle refers to combination of one upstroke and one down stroke.

Component Identification

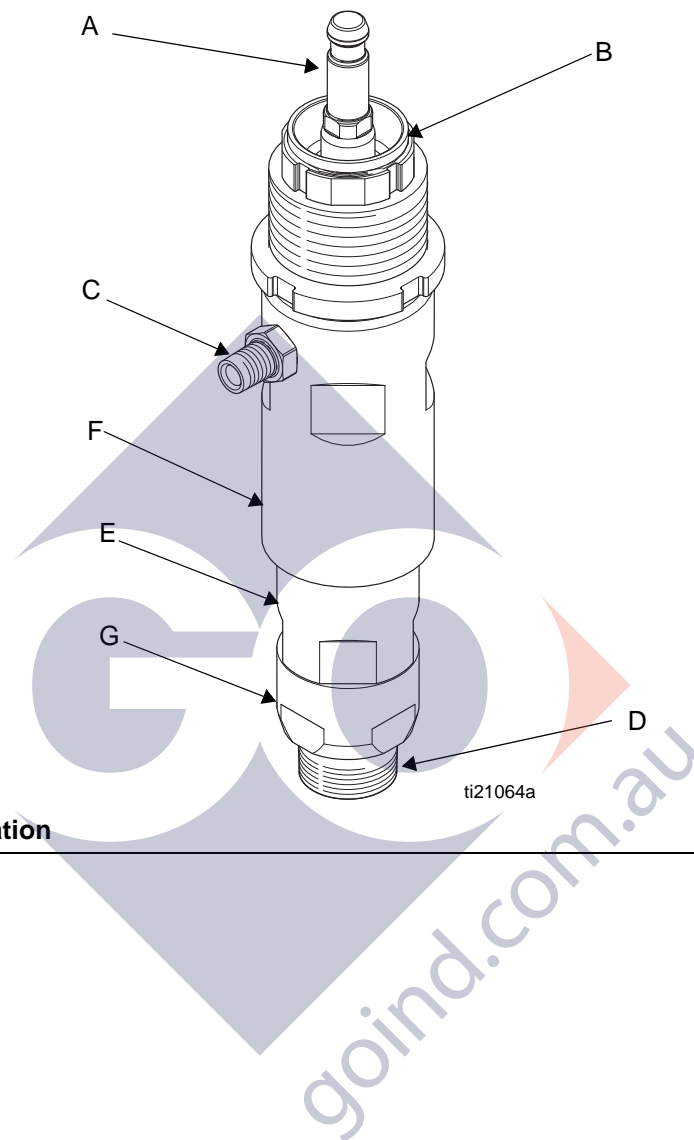

FIG. 1. Component Identification

Key:

- A Piston/Rod Assembly
- B Wet Cup
- C Fluid Outlet
- D Fluid Inlet
- E Lower Cylinder
- F Upper Cylinder
- G Intake Valve

Repair



General Information

NOTICE

Reference numbers and letters in parentheses in the text refer to the callouts in the figures and the parts drawing.

Always use Genuine Graco Parts and Accessories, available from your Graco distributor. If you supply your own accessories, be sure they are adequately sized and pressure rated for your system.

Preparation



Follow all warnings and instructions in your pump manual for the following preliminary steps:

1. Flush the equipment.
2. Relieve the pressure.
3. Remove the displacement pump from the pump assembly.

Disassembly

Lay out all removed parts in sequence to ease reassembly. Clean all parts with a compatible solvent and inspect them for wear or damage.

NOTICE

Repair Kits are available. See the chart on page 10 to order the correct kit(s) for your pump.

- Parts included in the Seal Repair Kit are marked with an *, for example 8*.
- Parts included in the Seat Repair Kit are marked with a †.
- Parts included in the Check Ball Kit are marked with a ◆.



Threads are very sharp. To avoid cuts, use a rag to protect hands when hand turning or carrying the displacement pump.

1. Place cylinder (1) sideways in a vise with soft jaws.
2. Use an adjustable wrench on hex of intake housing (23) to unscrew it from the lower cylinder (2). Loosen vice briefly and tip out the ball (24◆).

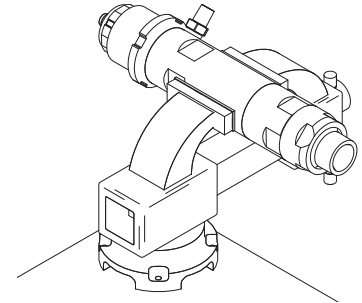

ti21066a

3. Remove the seat (22†) and use an o-ring pick to remove the seal (26†) from the intake housing. See FIG. 7.
4. Use an adjustable wrench on hex of lower cylinder (2) to remove it from the upper cylinder (1) and slide it straight off the pump. Be careful not to damage the piston/rod assembly (3).
5. Remove the o-ring (21*†) from the top of the lower cylinder.
6. Loosen the wet cup (5).
7. Pull the piston/rod assembly out the bottom of the upper cylinder. Remove the spring (10*), piston packings (12* and 13*) and glands (11* and 14*).
8. Remove the wet cup (5).
9. Remove the throat packings (7*, 8*) and glands (6*, 9*) from the bottom of the wet cup.

NOTICE

The jam nut can remain attached to the upper cylinder.

10. Remove the spring (4*) from the top of the upper cylinder (1).

11. Remove the upper cylinder seal (28*).
12. Clamp the piston in a vice. Use a hex wrench to remove the nut (17†) from end of piston.
 - 16U916: 7 mm (1/4 in.) hex
 - 16U917: 13 mm (1/2 in.) hex

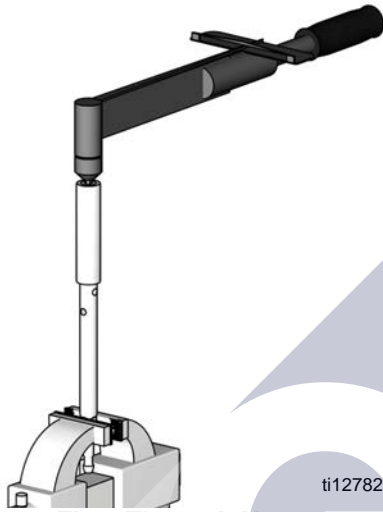

FIG. 2. Remove Flow-Through Nut

13. Remove the o-ring (18†), seat (15†) and ball (16◆). See FIG. 5.

Reassembly

1. Clean and inspect all parts.

NOTICE

Replace all o-rings removed from the pump. Compressed o-rings may cause the pump to leak.

2. Lubricate and install upper cylinder seal (28*).
3. Assemble the female gland (9*), v-packings (7*, 8*), and male gland (6*), as shown. Alternate the v-packings with the lips facing down. Lubricate the packings. Install the packing stack into the wet cup (5).

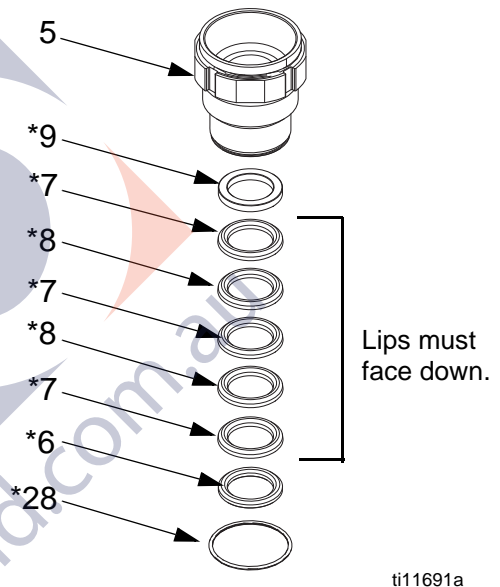

FIG. 3. Replace Throat Packings

4. Install the spring (4*) in the top of the upper cylinder.

NOTICE

All threads, packings, and seals must be well lubricated. Use Lubriplate (Graco Part Number 285791) or a similar product.

5. Lubricate the threads and screw the wet cup (5) into the upper cylinder (1), hand tight.

- Assemble the male gland (11*), v-packings (12*, 13*), and female gland (14*), as shown. Alternate the v-packings, with the lips facing up. Lubricate the packings. Install the spring (10*) and packing stack into the bottom of the upper cylinder (1).

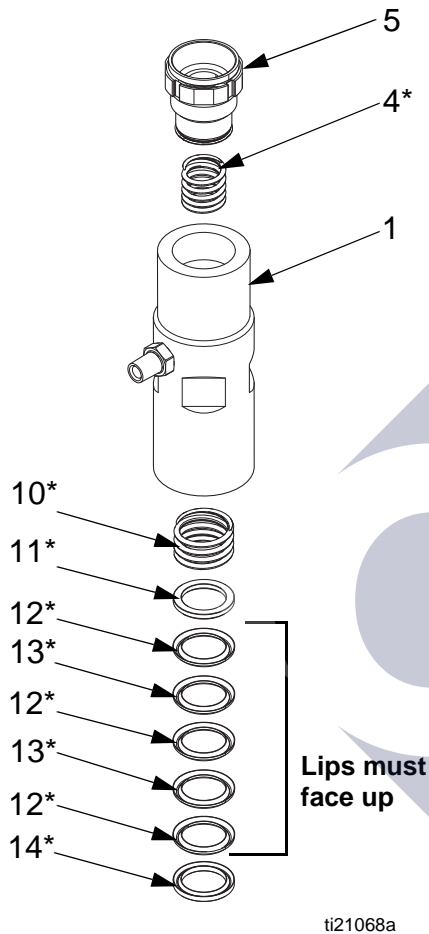

FIG. 4. Replace piston packings.

- Place the ball (16♦) in the piston body. Install the seat (15†) and o-ring (18†). Lubricate the o-ring and the threads of the flow-through nut (17†). Screw the flow-through nut (17†) into the piston/rod assembly (3).

- Place piston in vice and torque flow-through nut (17†) as specified in the following table.

Displacement Pump	Torque
16U916	54-66 ft-lb (73-89 N•m)
16U917	74-86 ft-lb (100-117 N•m)

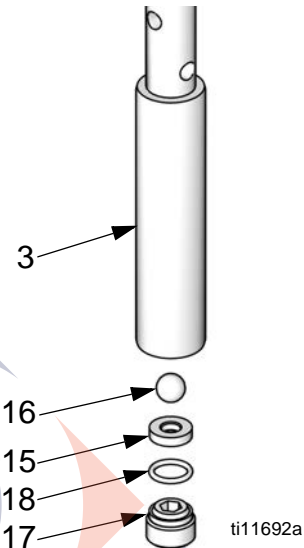

FIG. 5. Replace piston ball and seat.

- Push the piston/rod assembly (3) into the upper cylinder (1).
- Lubricate and install the seal (21*) on the top of the lower cylinder (2).

- Lubricate the threads and screw the lower cylinder (2) onto the upper cylinder (1). Torque to 90.5-109.5 ft-lb (123-149 N•m).

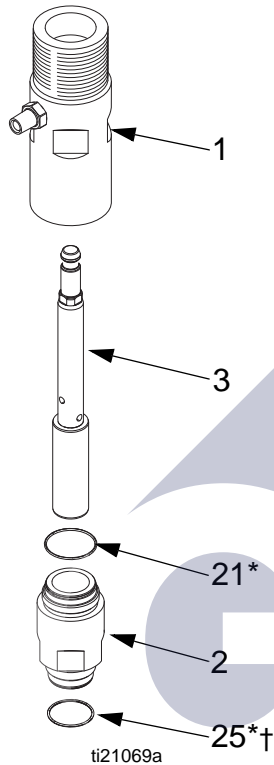

FIG. 6. Assemble piston/rod assembly and cylinders.

- Install the o-ring (26†) and intake seat (22†) into the top of the inlet housing. Lubricate the o-ring. The seat (22†) is reversible. Turn over or replace as needed.

- Lubricate the seal (25*†) and threads of the lower cylinder (2). Place the ball (24♦) on the seat (22†).

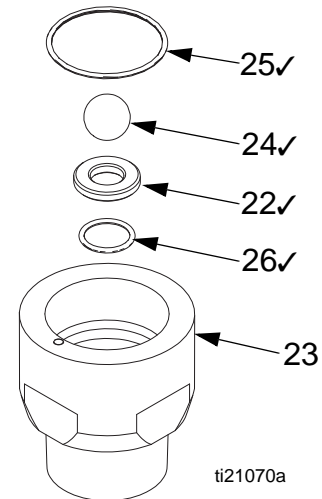
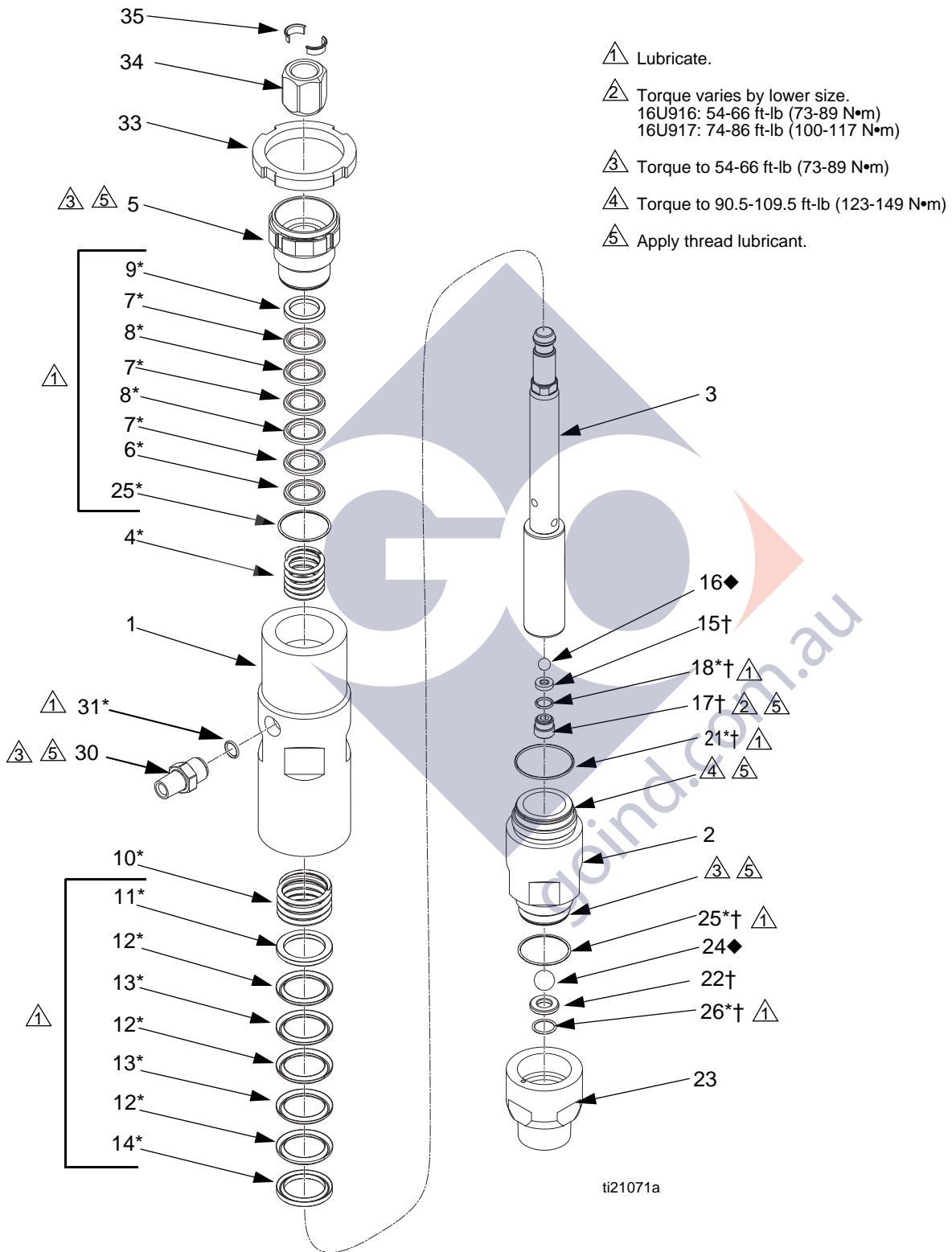

FIG. 7. Replace intake ball and seat.

- Keep upright to screw the housing (23) into the lower cylinder (2) hand tight, so the seat remains firmly in place. Then clamp the cylinder in a vice and torque to 54-66 ft-lb (73-89 N•m).
- Torque wet cup (5) to 54-66 ft-lb (73-89 N•m).

Parts



16U916, Merkur X72

16U917, Merkur X48

Ref.	Description	Part	Qty.
1	CYLINDER KIT, upper; includes 21, 28, 32, and 33 (qty. 1) 16U916 16U917	16U928 16U926	1
2	CYLINDER KIT, lower; includes 21 and 25 16U916 16U917	16U929 16U927	1
3	PISTON/ROD, assembly; includes 15-18, 36, and 37 (qty. 1) 16U916 16U917	24A644 24A645	1
4*	SPRING, throat	-----	1
5	WET CUP; includes 28 (qty. 1) 16U916 16U917	16U932 16U930	1
6*	GLAND, male, throat	-----	1
7*	PACKING, throat, UHMWPE	-----	3
8*	PACKING, throat, PTFE	-----	2
9*	GLAND, female, throat	-----	1
10*	SPRING, piston	-----	1
11*	GLAND, male, piston	-----	1
12*	PACKING, piston, UHMWPE	-----	3
13*	PACKING, piston, PTFE	-----	2
14*	GLAND, female, piston	-----	1
15†	SEAT, piston valve, tungsten carbide	-----	1
16◆	BALL, piston valve, stainless steel	-----	1
17†	NUT, flow through	-----	1
18*†	O-RING, piston (10 pack) 16U916 16U917	16V313 24P189	1
21*†	O-RING, lower cylinder (10 pack) 16U916 16U917	16V314 24P192	1
22†	SEAT, intake valve, tungsten carbide	-----	1
23	INTAKE VALVE KIT; includes 26 16U916 16U917	24A835 24A836	1
24◆	BALL, intake valve, stainless steel	-----	1

Ref.	Description	Part	Qty.
25*†	O-RING, lower cylinder (10 pack) 16U916 16U917	244896 24P196	2
26*†	O-RING, intake valve (10 pack)	24P194	1
31*	O-RING, outlet (10 pack)	24E457	1
30	FITTING, outlet, 3/8-18 npt x 3/4-16 unf; includes 33 (qty. 1)	-----	1
33	JAM NUT 16U916 16U917	24A635 24A636	1
34	NUT, coupling	15T311	1
35	COLLAR, coupling; pkg. of 10	24A619	1

----- Not sold separately.

* Included in Seal Repair Kit. See page 10.

† Included in Seat Repair Kit. Stainless steel seats also are available. See page 10.

◆ Included in Check Ball Kit. Tungsten carbide check balls also are available. See page 10.

Repair Kits

Description	16U916	16U917
Seal Repair Kit Throat v-packings (7* and 8*) and glands (6* and 9*), piston v-packings (12* and 13*) and glands (11* and 14*), o-rings (18*, 21*, 25*, 26*, and 33*), and springs (4* and 10*)	*24A252	*24A253
Seat Repair Kit - Tungsten Carbide (Standard) Seats (15† and 22†), o-rings (18†, 21†, 25†, and 26†), and flow-through nut (17†)	†24A782	†24A783
Check Ball Kit - 440 Stainless Steel (Standard) Piston ball (16◆) and intake ball (24◆)	◆24A261	◆24A263
Check Ball Kit - Tungsten Carbide Piston ball (16◆) and intake ball (24◆)	◆24A667	◆24A669
Standard Rebuild Kit Throat v-packings (7* and 8*) and glands (6* and 9*), piston v-packings (12* and 13*) and glands (11* and 14*), o-rings (18*, 21*, 25*, 26*, and 33*), springs (4* and 10*), piston valve ball (16), and intake valve ball (24).	16U924	16U925

Accessories

Description	16U916	16U917
Check Ball Kit - Tungsten Carbide Piston ball (16◆) and intake ball (24◆)	◆24A667	◆24A669
Check Ball Kit - 316 Stainless Steel Piston ball (16◆) and intake ball (24◆). Use with materials that cause chemical compatibility issues with 440 stainless steel or tungsten carbide, such as acid catalyst materials.	◆24P612	◆24P613
Reinforced PTFE V-Packing Kit Reinforced PTFE throat packings and glands, reinforced PTFE piston packings and glands, o-rings, and springs. Use with chemical resistance and higher temperatures.	24J853	24J854

Dimensions

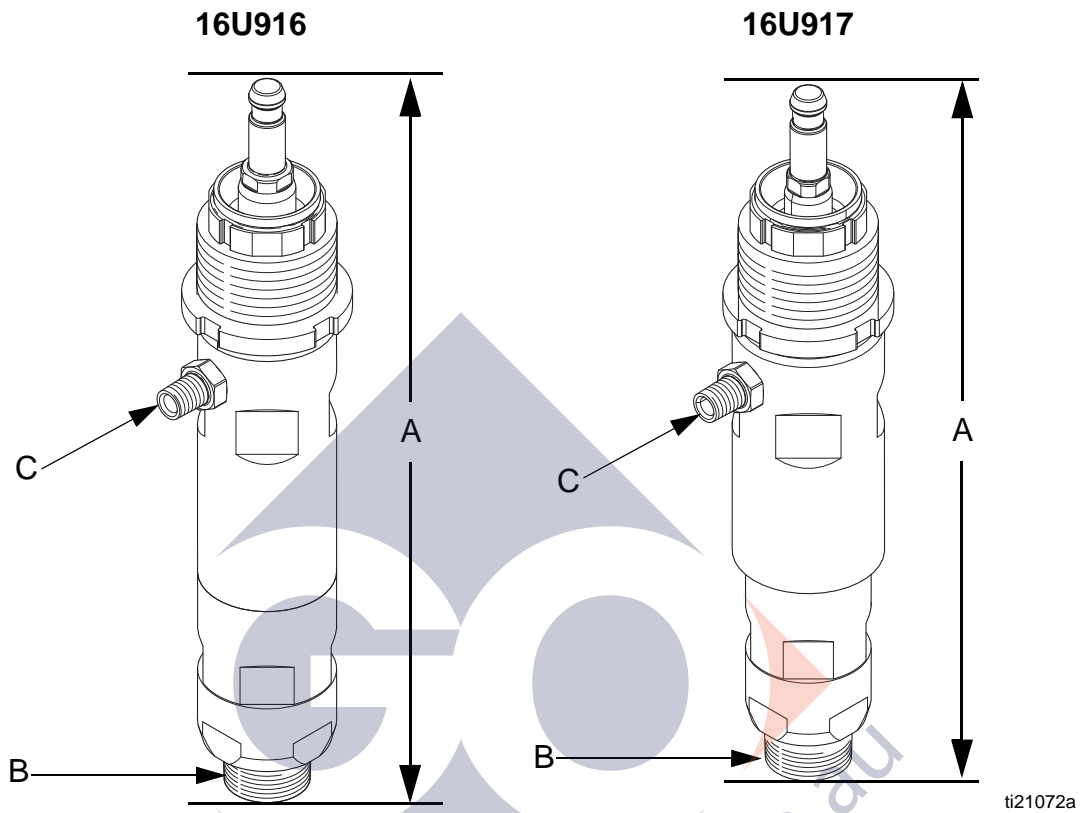

FIG. 8

Displacement Pump	A (Height*) in. (mm)	B (Inlet Size) in. npt	C (Outlet Size) in. npt	Weight lbs (kg)
16U916	15.2 (386)	1-1/4 in.	3/8 in.	15.5 (7)
16U917	15.7 (399)	1-1/4 in.	3/8 in.	16.1 (7.3)

* Height measured at mid-stroke.

Technical Data

Merkur High Pressure Displacement Pump		
	US	Metric
Maximum Operating Temperature	160°F	71°C
Stroke Length	2.5 in.	63.5 mm
Wetted Parts	carbon steel, tungsten carbide, UHMWPE, PTFE	
Maximum Fluid Working Pressure		
16U916	7200 psi	50 MPa, 500 bar
16U917	4800 psi	33 MPa, 330 bar
Inlet/Outlet Sizes		
Fluid inlet size	1-1/4 in. npt	
Fluid outlet size	3/8 in. npt	



Graco Standard Warranty

Graco warrants all equipment referenced in this document which is manufactured by Graco and bearing its name to be free from defects in material and workmanship on the date of sale to the original purchaser for use. With the exception of any special, extended, or limited warranty published by Graco, Graco will, for a period of twelve months from the date of sale, repair or replace any part of the equipment determined by Graco to be defective. This warranty applies only when the equipment is installed, operated and maintained in accordance with Graco's written recommendations.

This warranty does not cover, and Graco shall not be liable for general wear and tear, or any malfunction, damage or wear caused by faulty installation, misapplication, abrasion, corrosion, inadequate or improper maintenance, negligence, accident, tampering, or substitution of non-Graco component parts. Nor shall Graco be liable for malfunction, damage or wear caused by the incompatibility of Graco equipment with structures, accessories, equipment or materials not supplied by Graco, or the improper design, manufacture, installation, operation or maintenance of structures, accessories, equipment or materials not supplied by Graco.

This warranty is conditioned upon the prepaid return of the equipment claimed to be defective to an authorized Graco distributor for verification of the claimed defect. If the claimed defect is verified, Graco will repair or replace free of charge any defective parts. The equipment will be returned to the original purchaser transportation prepaid. If inspection of the equipment does not disclose any defect in material or workmanship, repairs will be made at a reasonable charge, which charges may include the costs of parts, labor, and transportation.

THIS WARRANTY IS EXCLUSIVE, AND IS IN LIEU OF ANY OTHER WARRANTIES, EXPRESS OR IMPLIED, INCLUDING BUT NOT LIMITED TO WARRANTY OF MERCHANTABILITY OR WARRANTY OF FITNESS FOR A PARTICULAR PURPOSE.

Graco's sole obligation and buyer's sole remedy for any breach of warranty shall be as set forth above. The buyer agrees that no other remedy (including, but not limited to, incidental or consequential damages for lost profits, lost sales, injury to person or property, or any other incidental or consequential loss) shall be available. Any action for breach of warranty must be brought within two (2) years of the date of sale.

GRACO MAKES NO WARRANTY, AND DISCLAIMS ALL IMPLIED WARRANTIES OF MERCHANTABILITY AND FITNESS FOR A PARTICULAR PURPOSE, IN CONNECTION WITH ACCESSORIES, EQUIPMENT, MATERIALS OR COMPONENTS SOLD BUT NOT MANUFACTURED BY GRACO. These items sold, but not manufactured by Graco (such as electric motors, switches, hose, etc.), are subject to the warranty, if any, of their manufacturer. Graco will provide purchaser with reasonable assistance in making any claim for breach of these warranties.

In no event will Graco be liable for indirect, incidental, special or consequential damages resulting from Graco supplying equipment hereunder, or the furnishing, performance, or use of any products or other goods sold hereto, whether due to a breach of contract, breach of warranty, the negligence of Graco, or otherwise.

FOR GRACO CANADA CUSTOMERS

The Parties acknowledge that they have required that the present document, as well as all documents, notices and legal proceedings entered into, given or instituted pursuant hereto or relating directly or indirectly hereto, be drawn up in English. Les parties reconnaissent avoir convenu que la rédaction du présente document sera en Anglais, ainsi que tous documents, avis et procédures judiciaires exécutés, donnés ou intentés, à la suite de ou en rapport, directement ou indirectement, avec les procédures concernées.

Graco Information

For the latest information about Graco products, visit www.graco.com.

TO PLACE AN ORDER, contact your Graco distributor or call to identify the nearest distributor.

Phone: 612-623-6921 **or Toll Free:** 1-800-328-0211 **Fax:** 612-378-3505

*All written and visual data contained in this document reflects the latest product information available at the time of publication.
Graco reserves the right to make changes at any time without notice.*

For patent information, see www.graco.com/patents.

Original instructions. This manual contains English. MM 332246

Graco Headquarters: Minneapolis
International Offices: Belgium, China, Japan, Korea

GRACO INC. AND SUBSIDIARIES • P.O. BOX 1441 • MINNEAPOLIS MN 55440-1441 • USA

Copyright 2013, Graco Inc. All Graco manufacturing locations are registered to ISO 9001.

www.graco.com

Revision C, October 2016