

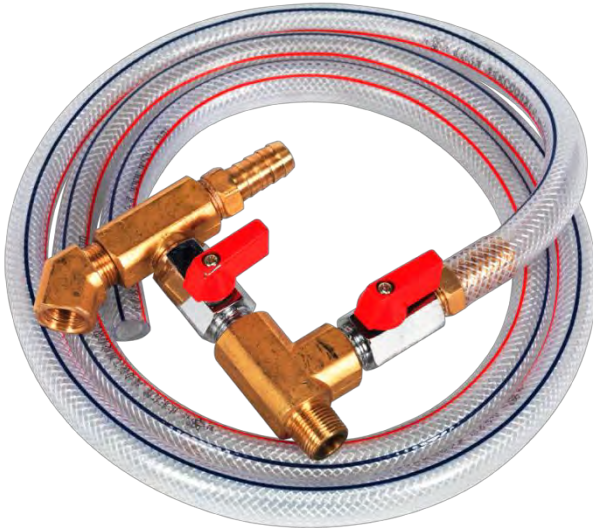

OWNER'S MANUAL
PRODUCT CODE: 3054

SODA BLASTING RETRO FIT KIT



WARNING**IMPORTANT: READ ALL INSTRUCTIONS BEFORE USE****WARNING**

The instructions and warnings contained in this manual should be read and understood before using or operating this equipment. Do not allow anyone to use or operate this equipment until they have read this manual and have developed a thorough understanding of how this equipment works. Failure to observe any of the instructions contained in the manual could result in severe personal injury to the user or bystanders, or cause damage to the equipment and property. Keep this manual in a convenient and safe place for future reference.

Whilst every effort has been made to ensure accuracy of information contained in this manual, the TQB Brands Pty Ltd policy of continuous improvement determines the right to make modifications without prior warning.

CONTENT

WARNING	2
CONTENT	2
SAFETY INSTRUCTIONS	3
ASSEMBLY, OPERATION, PREVENTITIVE MAINTENANCE	4
WARRANTY	6

SAFETY INSTRUCTIONS



SAFETY OPERATING INSTRUCTIONS

- ✓ Before using the soda blasting retro fit kit ensure it is in sound condition, and good working order.
- ✓ Turn off, or disconnect from, air supply before servicing or performing any maintenance and when unit is not in use. *Failure to comply with this instruction may damage the unit and will invalidate your warranty.*
- ✓ Replace or repair damaged parts. *Use recommended parts only. Non authorised parts may be dangerous and will invalidate the warranty.*
- ✓ Spillages of abrasive material, which may be slippery, must be cleaned up immediately to avoid injury.
- ✓ Always keep the blast nozzle directed at the work piece.
- ✓ Ensure all non essential persons keep a safe distance. Contact with high pressure blast or inhaling the dust generated is dangerous.
- ✓ Operators should maintain correct balance and footing. Ensure the floor is not slippery and wear non slip shoes.
- ✓ Wear approved ear, eye, hand and respiratory protection when operating the blaster.
- ✗ DO NOT operate unit if any parts are missing or damaged as this may cause failure and/or personal injury.

NOTE: This manual is only for the soda blasting retro fit kit.

ASSEMBLY, OPERATION, PREVENTITIVE MAINTENANCE

1. FEATURES

The Soda blasting retro fit kit is for use in conjunction with the 3060, 3008 and 3032 sand blasting kits. Quick and simple to fit and use.

Soda blasting is especially suitable in the classic car market as soda will not etch glass and will not warp or remove metalwork. The surface will be left smooth.

Soda also leaves a rust inhibitor behind for up to six weeks.

2. ASSEMBLY

Remove the Standard Manifold

1. Use a flat head screwdriver to loosen the hose clamp on the blasting hose and pull the hose off the connector (fig. 1A).
2. Unscrew the air hose from the manifold (fig.1B).
3. Unscrew the manifold from the bottom of the tank (fig.1C).

Fit Soda Blasting Manifold

1. Use PTFE tape on threaded connection for an air tight seal.
2. Screw in the new manifold until tight, use a spanner (fig.2A), ensure the air hose connection faces the back of the tank.
3. Screw in the air hose and tighten with a spanner (fig.2B).
4. Push the blasting hose onto the lower connector, tighten the clamp with a flat head screwdriver
5. If the exhaust hose is not connected push it onto the remaining connector (fig.2C).

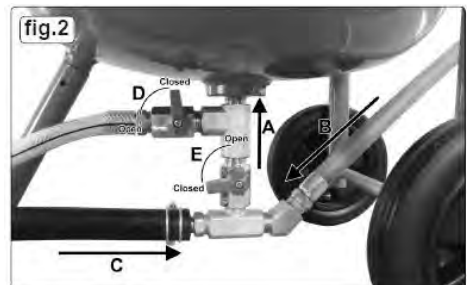
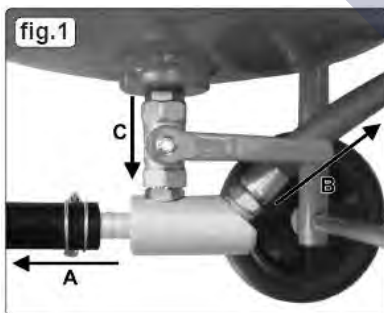

3. BEFORE USE

Prior to each use conduct a visual inspection by checking for abnormal conditions, such as cracked joints and damaged, loose, or missing parts.

4. OPERATION

Using the Soda Blasting Manifold

1. Before blasting ensure both valves on the manifold are in the closed position (fig.2).
2. After following the correct procedure in the manual for 3060, 3008 and 3032, open the lower soda metering valve (fig.2E).
3. If at some point the blaster gets clogged up, close the lower valve and open the exhaust valve (fig.2D), only open for a short time and ensure the hose is directed into a container or away from people and the work piece.

NOTE: Please refer to the manual for 3008 and 3032 for all maintenance instructions.

5. STORAGE

This Soda blasting retro fit kit should always be stored in a dry location.

6. MAINTENANCE

Turn off, or disconnect from, air supply before servicing or performing any maintenance and when unit is not in use. Failure to comply with this instruction may damage the unit and will invalidate your warranty.

Replace or repair damaged parts. Use recommended parts only. Non authorised parts may be dangerous and will invalidate the warranty.

Keep the soda blasting retro fit kit clean for best and safest performance.

7. SERVICE & REPAIR

Any Soda blasting retro fit kit found damaged in any way, or found to be worn or operates abnormally should be removed from service until repaired by an authorised service agent. Owners and / or operators should be aware that repair of this product may require specialised equipment and knowledge. Only authorised parts, labels and decals shall be used on this equipment. Annual inspection of the soda blasting retro fit kit is recommended and can be made by an authorised repair facility to ensure that your equipment is in optimum condition and that the equipment has the correct decals and safety labels specified by the manufacturer.

WARRANTY

Tradequip products have been carefully tested and inspected before shipment and are guaranteed to be free from defective materials and workmanship for a period of 12 months from the date of purchase except where tools are hired out when the guarantee period is ninety days from the date of purchase.

Should the machine develop any fault, please return the complete tool to your nearest authorised warranty repair agent or contact TQB Brands Pty Ltd Warranty team – warranty@tqbbrands.com.au.

If upon inspection it is found that the fault occurring is due to defective materials or workmanship, repairs will be carried out free of charge. This guarantee does not apply to normal wear and tear, nor does it cover any damage caused by misuse, careless or unsafe handling, alterations, accident, or repairs attempted or made by any personnel other than the authorised TQB Brands Pty Ltd repair agent.

This guarantee applies in lieu of any other guarantee expressed or implied and variations of its terms are not authorised.

Your TQB Brands Pty Ltd guarantee is not effective unless you can produce upon request a dated receipt or invoice to verify your proof of purchase within the 12 month period.

Consumer Guarantee

Our goods come with a guarantee that cannot be excluded under the Australian Consumer Law. You are entitled to a replacement or refund for a major failure and compensation for any other reasonably foreseeable loss or damage. You are also entitled to have the goods repaired or replaced if the goods fail to be of acceptable quality and the failure does not amount to a major failure.