



GENERAL PURPOSE ENGINE

GX35

PARTS CATALOGUE

1



GX35

FOREWORD INDEX

1

ENGINE GROUP

2

PART NUMBER INDEX

3

PART NAME INDEX

4



Instruction for use of parts catalogue

- **This parts catalogue has been created as of November 20, 2003.**
- Since this date, the sales practice for repair parts may have been changed or the parts may have been eliminated (listed for those not for sale).
- The modified information is reflected on the latest Electronic Parts Catalogue (EPC). Also, refer to the parts catalogue news for any change.
- See the parts catalogue news for any revision that is made after November 20, 2003.
- **Always specify the part number when ordering a part.**
- Check the model, type, serial numbers, color, maker, and the size as needed before ordering a part.
- Note that the illustrations (part drawings) can differ from the actual parts in shape. They are given just to help you to refer to the parts.
- **When modifications or additions to this parts catalogue are made, a revised edition will be issued at an appropriate time, with successively progressing revision numbers on the cover. We recommend obtaining such revisions in order to keep your parts catalogue up-to-date at all times. To check whether a parts catalogue revision has been issued, please contact your Honda distributor.**

Initial version issue date **November 20, 2003**
Honda Motor Co., Ltd.

CONTENTS

	Page	Address No.	
• How to refer to the part information	2	B 2	1
• Part catalogue structure	3	B 3	
• When the parts were revised	4	B 4	
• Abbreviations used in the parts catalogue.....	4	B 4	
• How to check the part block and serial numbers.....	5	B 5	
• Models, parts catalogue codes and applicable serial numbers	6	B 6	
• Features of each type.....	7	B 7	
• Fuel hose, general purpose hoses and vinyl hose.....	8	B 8	
• How to use the flat rate time (F.R.T.)	9	B 9	
• Illustrated index	11	B11	
• ENGINE GROUP.....	13	C 1	2
• PART NO. INDEX.....	28	D 1	3
• PART NAME INDEX.....	29	E 1	4

How to refer to the part information

A Reference with "Illustrated index"

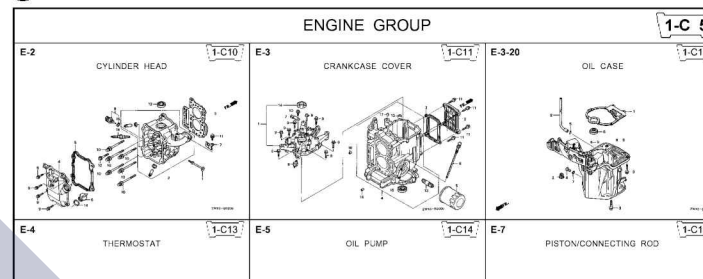

B Reference with "Part number index"

PART NO. INDEX

Part Number	Address	Page	Ref.	Part Number	Address	Page
06000				15212-ZW9-000	1-C14	3C
06316-ZW9-000	1-G9	88	1	15220-ZW9-003	1-C14	3C
11000				15332-ZW9-000	1-E8	55
11300-ZW9-405	1-C11	27	1	15332-ZW9-A30	1-E11	5E
11300-ZW9-406	1-C11	27	1	15400-PFB-004	1-C11	27
11340-ZW9-000	1-C11	27	2	15422-ZW9-000	1-C14	3C
11342-ZW9-000	1-C11	27	3	15473-881-000	1-C14	3C
11381-ZW9-003	1-C12	28	1	15474-ZW9-000	1-C14	3C
				15611-921-000	1-C10	2E
				15655-ZW9-000	1-C11	27
12000				16000		
12000-ZW9-405ZA	1-C11	27	4	16010-ZV4-005	1-D4	3E
12155-ZV4-A00	1-C13	29	1	16011-ZV4-005	1-D4	3E
12166-ZW9-000	1-C10	26	1	16013-ZW9-003	1-D4	3E
12209-GB4-681	1-C16	32	1	16016-ZW9-003	1-D4	3E
12210-ZW9-405ZA	1-C10	26	2	16016-ZW9-721	1-D4	3E
12216-ZE2-300	1-E8	55	1	16023-ZW9-003	1-D4	3E
	1-E11	58	1	16024-ZV4-650	1-D4	3E
				16028-ZV4-650	1-D4	3E

C Reference with "Part name index"

PART NAME INDEX

Part name	Address	Page	Ref.
[A]			
ABSORBER , FUEL	1-E15	62	5
ARMATURE COMP.	1-D11	43	7
ARM COMP. , LINK JOINT	1-G6	85	18
ARM COMP. , SHIFT LINK	1-G6	85	14
ARM COMP. , TILT	1-F15	79	20
ARM , FUEL PUMP ROCKER	1-C16	32	4
ARM , REVERSE LOCK	1-F15	79	18
ARM , SHIFT LINK	1-F11	74	7
ARM , STOPPER	1-D1	33	12
ARM , THROTTLE REMOTE	1-F11	74	6
ARM , VALVE ROCKER	1-C16	32	3
[B]			
BAG , TOOL , 160MM	1-G5	84	10
BAND	1-G6	86	37
BAND B1 , WIRE	1-F6	69	1
BAND , CORD	1-F3	67	18
BAND , TUBE CLIP , 11MM	1-E15	63	20
BAND , TUBE CLIP , 12.5MM	1-E15	63	19

CYLINDER HEAD (1-C10)

Block No.

Ref No.

Address No.

Service item F.R.T.

O-RING, 26X2.7	0.1
PLUG, SPARK	0.2
O-RING, 9.5X1.5	0.2
SENSOR ASSY., WATER	0.3
COVER COMP., HEAD	0.5
PACKING, HEAD COVER	1.8
GASKET, CYLINDER HEAD	2.4
OIL SEAL, 20X32X6	2.4
HEAD COMP., CYLINDER	3.1

Ref. No.	Part No.	Description	Reqd. QTY						Serial No.	Parts catalogue code
			990	990T	9901	1001	1001	10B1		
1	12166-ZW9-000	STOPPER, ENGINE SIDE	2	2	2	2	2	2		
2	12210-ZW9-000ZA	HEAD COMP., CYLINDER	1	1	1	1	1	1		
3	12251-ZW9-003	GASKET, CYLINDER HEAD	1	1	1	1	1	1		
4	12310-ZW9-000	COVER COMP., HEAD	1	1	1	1	1	1		
5	12312-ZW9-000	PACKING, HEAD COVER	1	1	1	1	1	1		
6	15611-921-000	CAP, OIL (NO GAUGE)	1	1	1	1	1	1		
7	16617-ZW9-000	HOLDER, CABLE	1	1	1	1	1	1	SC,S6	
	16617-ZW9-010		1	1	1	1	1	1	1001800 LHC,LHD	
			1	1	1	1	1	1	1001801 LHC,LHD	
8	35673-ZW5-003	SENSOR ASSY., WATER	1	1	1	1	1	1		
9	90003-ZW9-000	BOLT, FLANGE, 6X22	4	4	4	4	4	4		
10	90007-ZW9-003	BOLT, FLANGE, 8X83	6	6	6	6	6	6		
11	90011-ZW9-000	BOLT, FLANGE, 6X14 (CT200)	1	1	1	1	1	1		
12	90020-ZW9-000	BOLT, FLANGE, 3X40	2	2	2	2	2	2		
13	91205-K49-003	OIL SEAL, 20X32X6	1	1	1	1	1	1		
14	91301-805-000	O-RING, 26X2.7	1	1	1	1	1	1		
15	91307-PK2-005	O-RING, 9.5X1.5 (HONDA KIKAKI)	1	1	1	1	1	1		
16	98059-55916	PLUG, SPARK (CR5EH-9)	2	2	2	2	2	2		
	98059-55926	PLUG, SPARK (U16FER9)	2	2	2	2	2	2		

2000.09.20 E

Page No.

Part catalogue structure

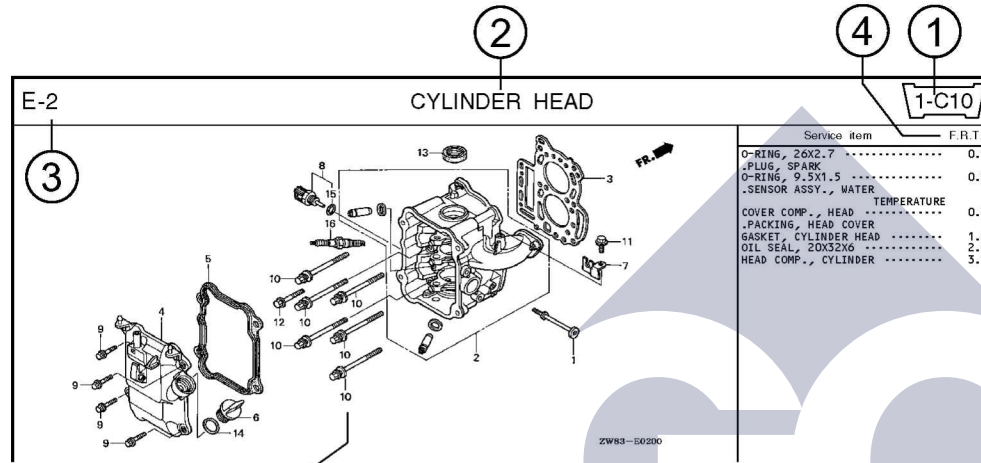

Ref. No.	Part No.	Description	Reqd. QTY						Serial No.	Parts catalogue code
			BF 93D1	BFP 93D1	BF 10D1	BFP 10D1	BF 10E1	BFP 10E1		
1	12166-zw9-000	STOPPER, ENGINE SIDE	2	2	2	2	2	2		
2	12210-zw9-000ZA	HEAD COMP., CYLINDER *H8*								
3	12251-zw9-003	GASKET, CYLINDER HEAD	1	1	1	1	1	1		
4	12310-zw9-000	COVER COMP., HEAD	1	1	1	1	1	1		
5	12312-zw9-000	PACKING, HEAD COVER	1	1	1	1	1	1		
6	15611-921-000	CAP, OIL	1	1	1	1	1	1		
7	16617-zw9-000	HOLDER, CABLE	1	1	1	1	1	1	SC,SG	
	16617-zw9-010		1	1	1	1	1	1	1001800 LHC,LHD	

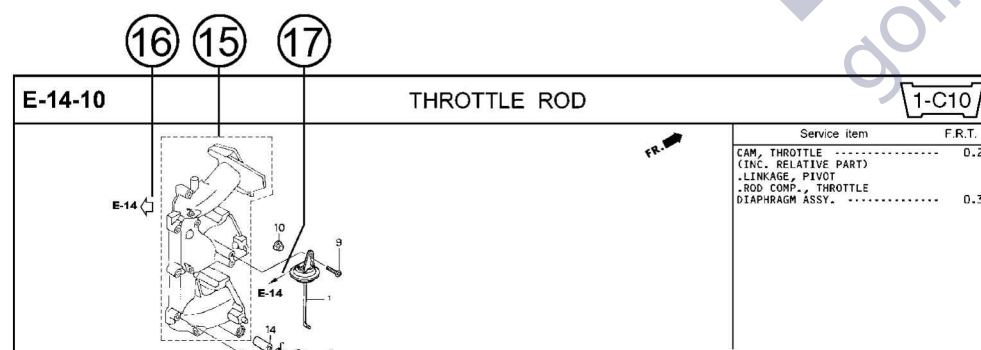

① Address number

- Address No. is provided (in place of the page No.) to help you refer to the part with the part No. or part name.

② Block title ③ Block number

④ Service item/Flat rate time

⑤ Reference number

- Title number marked with the parenthesis or parentheses indicates that it continues from the previous page.

⑥ Part number ⑦ Honda color code

⑧ Description

⑨ Assemblies

- Sections framed with broken lines in the exploded view drawings are available as complete assemblies. (Their individual parts can also be obtained.)

⑩ Color description

⑪ Note

- Notes are shown with the parentheses in the part name column.

⑫ Required quantity

- Required QTY shown in the parenthesis or parentheses indicates the optional part.
- Required QTY marked with "N" Indicates the optional part that should be selected as needed.
- Required QTY indicates the number of the part used in the block.

⑬ Serial number

⑭ Type

- When the type column is blank, it indicates that the part is applicable to all types.
- As the type of the actual unit may differ from the "parts catalogue, type" please refer to "Models, types and applicable serial numbers" for confirmation.

⑮

- Parts enclosed within a dotted line are covered in a different block.

⑯

- A hollow arrow indicates the block No. for the parts enclosed within a dotted line.

⑰

- A solid arrow indicates the block No. the part in question is connected to.

When the parts were revised

Abbreviations used in the parts catalogue

• The following abbreviations are used in the parts name column.

- | | |
|--|-----------------------------|
| A Ampere | FR.Front |
| A.C. Alternating current | IN.Inlet |
| ASSY. Assembly | L (100L) .Link (100 Links) |
| AT. Automatic transmission | L.Left |
| C.D.I. Capacitive discharge ignition | MMMillimeter |
| COMP. ... Complete | MT.Manual Transmission |
| D.C. Direct current | P.T.O.Power take off |
| EX. Exhaust | R.Right |
| G.F.C.I ... Ground fault circuit interruptor | RR.Rear |
| HEX. Hexagonal | STD.Standard |
| H.S.T. Hydrostatic transmission | T (22T) ...Tooth (22 Teeth) |
| | VVolt |
| | WWatt |

Be sure to check the serial number!!



Ref. No.	Part No.	Description	Reqd. QTY						Serial No.
			BF 9.9D1	BFP 9.9D1	BF 10D1	BFP 10D1	BF 10B1	BFP 10B1	
1	12166-ZW9-000	STOPPER, ENGINE SIDE	2	2	2	2	2	2	
2	12210-ZW9-000ZA	HEAD COMP., CYLINDER *NH8* DARK GRAY	1	1	1	1	1	1	
3	12251-ZW9-003	GASKET, CYLINDER HEAD	1	1	1	1	1	1	
4	12310-ZW9-000	COVER COMP., HEAD	1	1	1	1	1	1	
5	12312-ZW9-000	PACKING, HEAD COVER	1	1	1	1	1	1	
6	15611-921-000	CAP, OIL (NO GAUGE)	1	1	1	1	1	1	
7	16617-ZW9-000	HOLDER, CABLE (###)	1	1	1	1	1	1	
	16617-ZW9-010	1	1	1	1	1	1	



The number has been used from the initial model without revision. When shown at the left side, it is applicable to the models of No.1001801 and the subsequent numbers. When shown at the right side, it is applicable to the models up to No.1001800.

• The parts listed with "###" at the end of the parts name have limited supply period (parts not for sale).

goind.com.au

How to check the part block and serial numbers

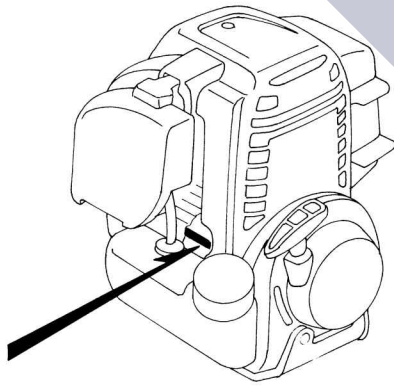
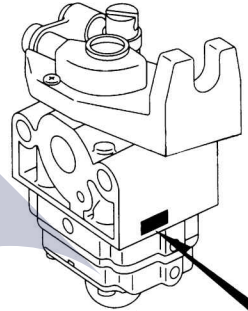
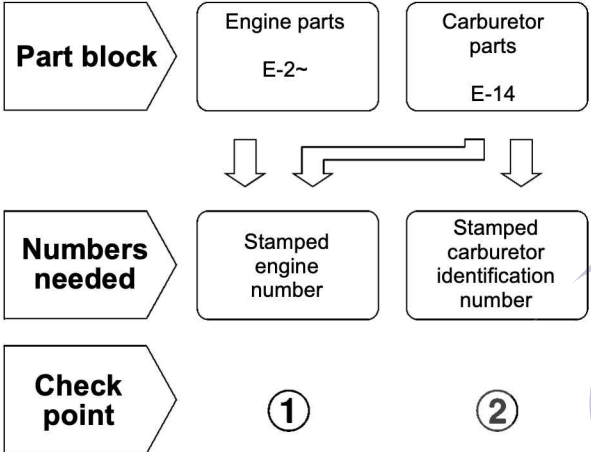

Models, parts catalogue codes and applicable serial numbers

- Models, parts catalogue codes and applicable serial Nos. given in this parts catalogue can be identified as follows.

Model	Type	Parts catalogue type	Applicable engine serial No.	Applicable carburetor identification No.
GX35	SAT	SAT	GCACM-1000001~	WYB 16A
	SAU	SAU		WYB 15A
	SAUT	SAUT		WYB 16A
	SA2	SA2		
	SCT	SCT		WYB 14A
	SC2	SC2		
	SD	SD		
	SDT	SDT		
	SE	SE		
	SET	SET		
	SJ	SJ		
	SJT	SJT		WYB 15A
	SUT	SUT		

* Of carburetor identification numbers, only the portions underlined in the example below are used for registration.

WYB 16A KC †

Features of each type

- See the following table for the features of each type.

Specifications	Model	GX35												
	Type	SAT	SAU	SAUT	SA2	SCT	SC2	SD	SDT	SE	SET	SJ	SJT	SUT
Spark arrester		•	•	•	•	•	•							•
Tank guard		•		•		•			•		•		•	•

Fuel hose, general purpose hoses and vinyl hose

- The standard part fuel hose, general purpose hose and vinyl hose may be substituted by the coiled bulk part.
- When ordering the standard part fuel hose, general purpose hose and vinyl hose use the bulk part number written in the parts catalog in brackets () underneath the part name.
- When exchanging the hose, cut and use at the specified length as mentioned in the part name.
(For the method of cutting the bulk part, and method of filling out orders etc., please refer to the instructions issued with the bulk part.)

Bulk part number of fuel hose, general purpose hose and vinyl hose.

Example: 9 5 0 0 1 - 7 5 0 0 1 - 5 0 M

Bulk part number:
Refers to the bulk part.

Marking code (fuel hose and general purpose hose)

Change code (Vinyl hose)

Indicates number mark or change sequence, however, the code for the bulk part must be strictly 0 (zero).

Types of code:

- Fuel hose
 - 2: Red outside braid (3 mm inside dia. only)
 - 5: Black inside braid
 - 3: Red (3 mm inside dia. only)
 - 4: Ash gray with red stripe (3 mm inside dia. only)
 - 6: Black

- General hose
 - 1: Ash gray
 - 2: Ash gray
 - 3: Black
 - 5: Black

- Vinyl hose
 - 1: Clear
 - 2: Black
 - 3: Light red
 - 6: Light red
 - 7: Pale black

Lengths:

- 001: 1 m (standard)
 - 003: 3 m
 - 008: 8 m
- Application or specification of some parts is not settled.

I.D code: (fuel hose and general purpose hose)

- | | | | | |
|------------|--------------------|--------------------|-----------------------------|-----------------------------|
| 30: 3.0 mm | 50: 5.0 mm | 70: 7.0 mm | 11: 11 mm | 12: 12 (outside dia. 17) mm |
| 35: 3.5 mm | 55: 5.3 mm, 5.5 mm | 75: 7.3 mm, 7.5 mm | 91: 12 (outside dia. 15) mm | 14: 14 mm |
| 45: 4.5 mm | 65: 6.5 mm | 80: 8.0 mm | 92: 12 (outside dia. 16) mm | 17: 17 mm |

ID./OD. code: (vinyl hose)

- | | | | | |
|-------------------------|--------------------------|---------------------------|---------------------------|---------------------------|
| 01: ID. 2.9, OD. 6.8 mm | 12: ID. 5.0, OD. 7.0 mm | 21: ID. 8.0, OD. 9.0 mm | 37: ID. 11.0, OD. 15.0 mm | 50: ID. 16.0, OD. 19.0 mm |
| 03: ID. 3.0, OD. 6.0 mm | 10: ID. 5.0, OD. 8.0 mm | 23: ID. 8.0, OD. 12.0 mm | 38: ID. 12.0, OD. 13.0 mm | 55: ID. 17.5, OD. 20.5 mm |
| 05: ID. 3.5, OD. 6.5 mm | 11: ID. 5.0, OD. 9.0 mm | 25: ID. 9.0, OD. 11.0 mm | 39: ID. 12.0, OD. 14.0 mm | 60: ID. 22.0, OD. 27.0 mm |
| 07: ID. 4.0, OD. 7.0 mm | 14: ID. 6.0, OD. 9.0 mm | 27: ID. 9.0, OD. 13.0 mm | 40: ID. 12.0, OD. 16.0 mm | |
| 08: ID. 4.5, OD. 6.5 mm | 17: ID. 7.0, OD. 9.0 mm | 33: ID. 10.0, OD. 14.0 mm | 43: ID. 13.0, OD. 15.0 mm | |
| 09: ID. 4.5, OD. 8.0 mm | 19: ID. 7.0, OD. 11.0 mm | 36: ID. 11.0, OD. 13.0 mm | 45: ID. 14.0, OD. 18.0 mm | |

Hose type:

- 1: Fuel hose
- 3: Vinyl hose
- 5: General hose

⊙ **CAUTION: It is DANGEROUS to confuse the fuel hose with the general purpose hose or vinyl hose.**

Never use a general purpose hose or vinyl hose in place of a fuel hose or vice versa. Always use the correct bulk part in the parts catalogue, according to the service manual or the instructions issued with the bulk part.

How to use the flat rate time (F.R.T.)

This F.R.T. (Flat Rate Time) is used to determine the standard labor time allowed for replacement of parts covered by the warranty during the period the warranty is in effect. The F.R.T. for those parts which are not listed herein should be determined from the operation closely related to the replacement of that part.

1. The F.R.T. is based on the following servicing conditions

- a. A liberal allowance is added to the net servicing time.
- b. Standard times specified are based on the condition that the necessary servicing tools listed in the service manual which describes the Honda service policy are available close at hand and the work performed by a mechanic with normal skill.
- c. Time required for inspection and operational test following the servicing is included in the F.R.T.
- d. The F.R.T. for "*" marked parts are same as the F.R.T. for the representative part above.
- e. The F.R.T. shown with (*) includes engine removal and installation.

2. Method of computing

The job times are listed in tenth of an hour to simplify computation.

(Example) 0.3 = 18 minutes
5.6 = 5 hours and 36 minutes

Hours	Minutes	Hours	Minutes
0.1	6	0.6	36
0.2	12	0.7	42
0.3	18	0.8	48
0.4	24	0.9	54
0.5	30	1.0	60

3. Computing the F.R.T.

The following are only examples and do not reflect the actual F.R.T. for this product.

When several jobs are performed at the same time, make the calculation in the following manner.

a. Jobs of non duplicated nature

The F.R.T. for the job is obtained by totalling the F.R.T. for each part replaced.

(Example) Replacement of head cover gasket and oil filter.

Service item	F.R.T.
Packing, cylinder head cover	0.5
Cartridge, oil filter	0.5

The F.R.T. for the job is: $0.5 + 0.5 = 1.0$

b. Jobs of duplicated nature

Take the F.R.T. for the last part to be replaced.

(Example) Replacement of piston and cylinder head gasket.

Service item	F.R.T.
Gasket comp., cylinder head	3.0
Piston	*5.0

The F.R.T. for the job is: 5.0

c. Jobs of partially related nature

Total up the F.R.T. for all of the parts replaced and then subtract the F.R.T. for the duplicated operation (i.e., cylinder head gasket service).

(Example) Replacement of valve and cylinder head.

Service item	F.R.T.
Valve	*3.0
Head assy., cylinder	*4.0
Gasket comp., cylinder head	*2.5

The F.R.T. for the job is: $(3.0 + 4.0) - 2.5 = 4.5$

- The F.R.T. shown with (*) includes engine removal and installation.
- The parts, having the same number of man-hour, are identified by a mark "*", and classified under the title of their representative work.

4. Adjustment, cleaning

Item	Service item	F.R.T.
Adjustment	Valve clearance	0.2
	Carburetor	0.2
Cleaning	Carburetor	0.4
	Air cleaner element	0.1
	Spark arrester	0.1
	Spark plug	0.1

ENGINE GROUP

B11

E-2

CRANKCASE SET

C 1

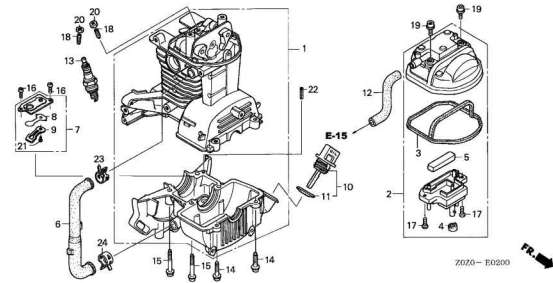

E-7

CRANKSHAFT/PISTON

C 3

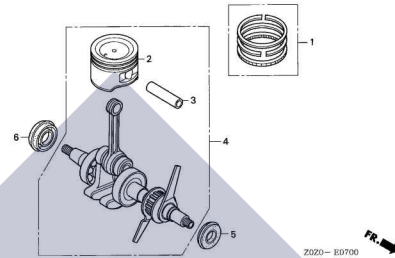

E-10

CAM PULLEY

C 4

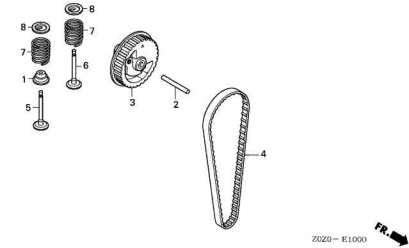

E-11

RECOIL STARTER

C 5

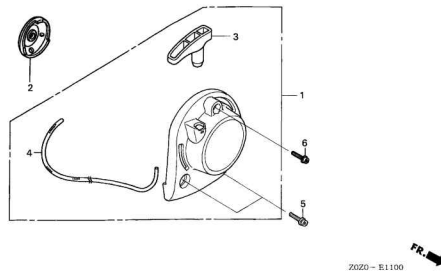

E-12

FAN COVER/CLUTCH

C 6

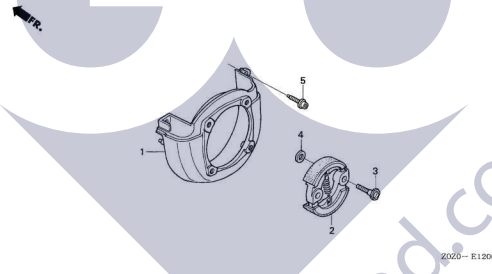

E-14

CARBURETOR

C 7

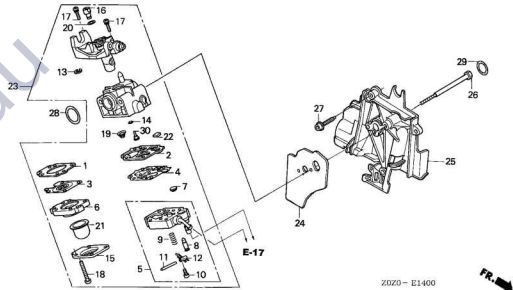

E-15

AIR CLEANER

C 9

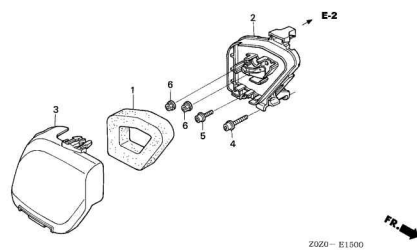

E-16

MUFFLER

C10

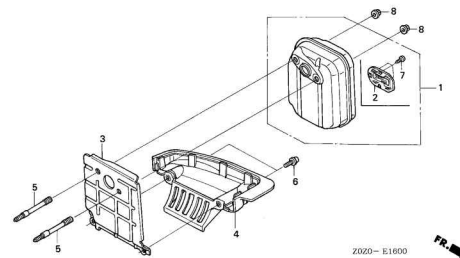

E-17

FUEL TANK

C11

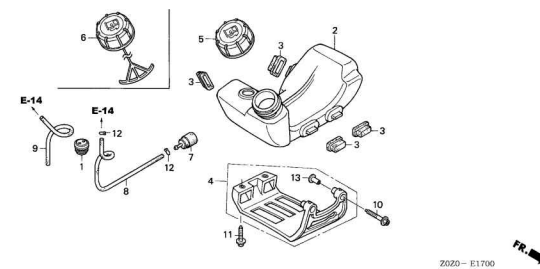

2

ENGINE GROUP

B12

E-19

FLYWHEEL

C12

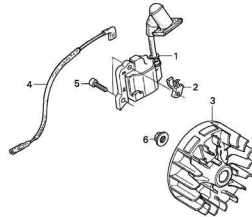

ZOZO - E1900
FR. →

E-27

TOP COVER

C13

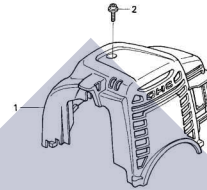

ZOZO - E2700
FR. →

E-28

LABEL

C14

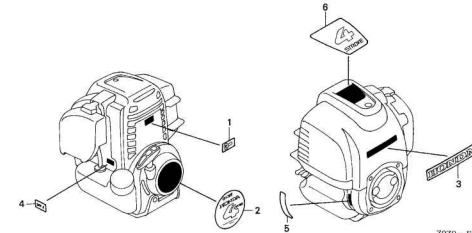

ZOZO - E2800

E-29

TOOL

C15

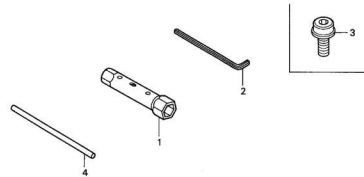

ZOZO - E2900

GO
goind.com.au

2

E-2

CRANKCASE SET

C 1

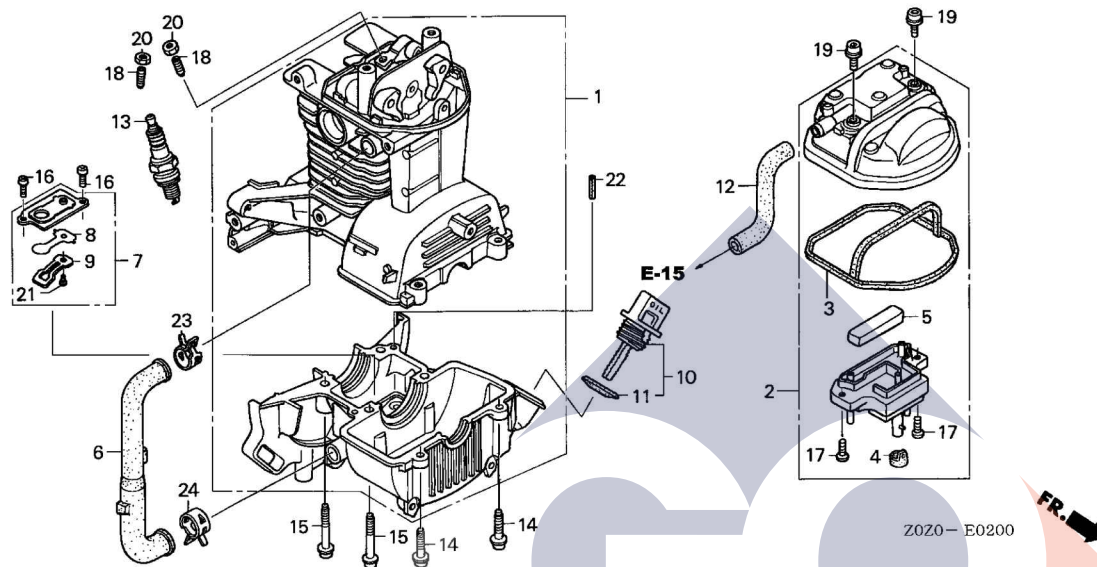

Service item	F.R.T.
COVER, CYLINDER HEAD	0.1
.PLUG, SPARK	
.SEAL, HEAD COVER	
TUBE, BREATHER	0.2
TUBE, OIL	0.4
PLATE ASSY., OIL OUTLET VALVE	1.0
CRANKCASE SET	1.5

Ref. No.	Part No.	Description	Reqd. QTY		Serial No.	Parts catalogue code
			GX	35		
1	10100-Z0Z-405	CRANKCASE SET	1			
2	12310-Z0Z-000	COVER, CYLINDER HEAD	1			
3	12312-Z0Z-300	SEAL, HEAD COVER	1			
4	12314-Z0H-300	GROMMET, HEAD COVER	1			
5	12367-Z0H-000	FILTER, BREATHER	1			
6	15422-Z0Z-000	TUBE, OIL	1			
7	15510-Z0H-000	PLATE ASSY., OIL OUTLET VALVE	1			
8	15571-ZM3-003	VALVE, OIL OUTLET	1			
9	15572-Z0H-000	PLATE, STOPPER	1			
10	15600-ZM3-003	CAP ASSY., OIL FILLER	1			
11	15625-ZE1-003	PACKING, OIL FILLER CAP	1			
12	15721-Z0Z-000	TUBE, BREATHER	1			
13	31914-Z0H-003	PLUG, SPARK (CMR4H) (NGK)	(1)		SAT,SAU,SAUT,SA2,SCT,SC2,SD,SDT,SE,SET,SUT	
	31914-Z0H-801	PLUG, SPARK (CM4H) (NGK)	(1)		SJ,SJT	
	31915-Z0H-003	PLUG, SPARK (CMR5H) (NGK)	1		SAT,SAU,SAUT,SA2,SCT,SC2,SD,SDT,SE,SET,SUT	
	31915-Z0H-801	PLUG, SPARK (CM5H) (NGK)	1		SJ,SJT	
	31916-Z0H-003	PLUG, SPARK (CMR6H) (NGK)	(1)		SAT,SAU,SAUT,SA2,SCT,SC2,SD,SDT,SE,SET,SUT	
	31916-Z0H-801	PLUG, SPARK (CM6H) (NGK)	(1)		SJ,SJT	
14	90009-Z0H-003	BOLT, SOCKET, 5X20	2			
15	90010-Z0Z-003	BOLT, SOCKET, 5X32	4			
16	90013-Z0H-004	SCREW, PAN, 4X8	2			
17	90013-Z0Z-003	SCREW, PAN, 4X8	2			
18	90017-Z0H-000	SCREW, TAPPET ADJUSTING	2			
19	90019-Z0H-003	BOLT, SOCKET, 5X12	2			
20	90206-ZM3-000	NUT, TAPPET ADJUSTING	2			

2

E-2

CRANKCASE SET

C 2

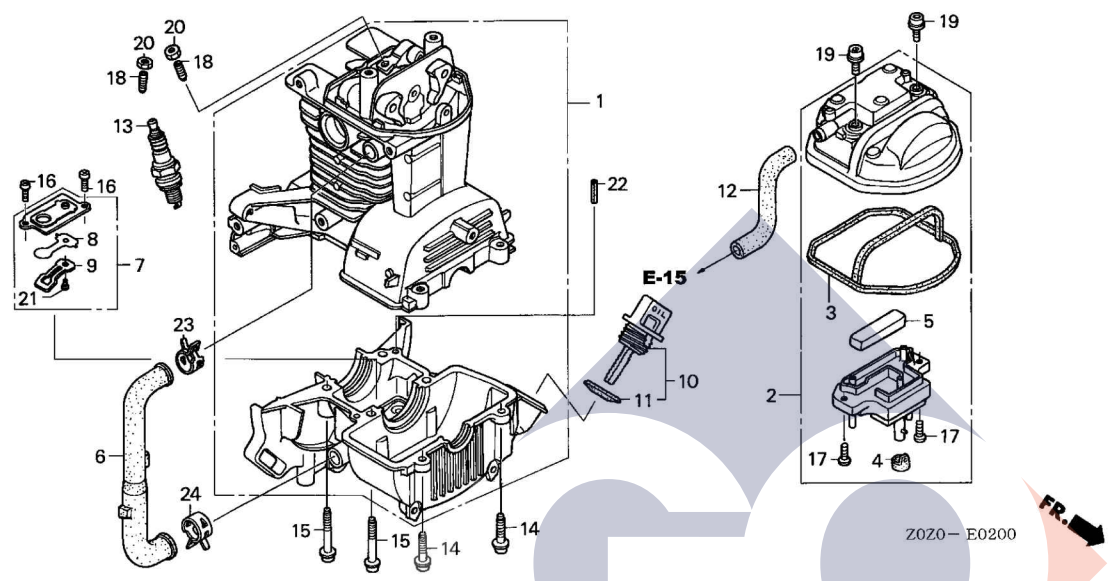

Z0Z0-E0200

Ref. No.	Part No.	Description	Reqd. QTY		Serial No.	Parts catalogue code
			GX	35		
21	93500-03005-0A	SCREW, PAN, 3X5	1			
22	94305-40102	PIN, SPRING, 4X10	1			
23	95002-41200-08	CLAMP, TUBE (D12)	1			
24	95002-41300-04	CLAMP, TUBE (D13)	1			

goind.com

2

E-7

CRANKSHAFT/PISTON

C 3

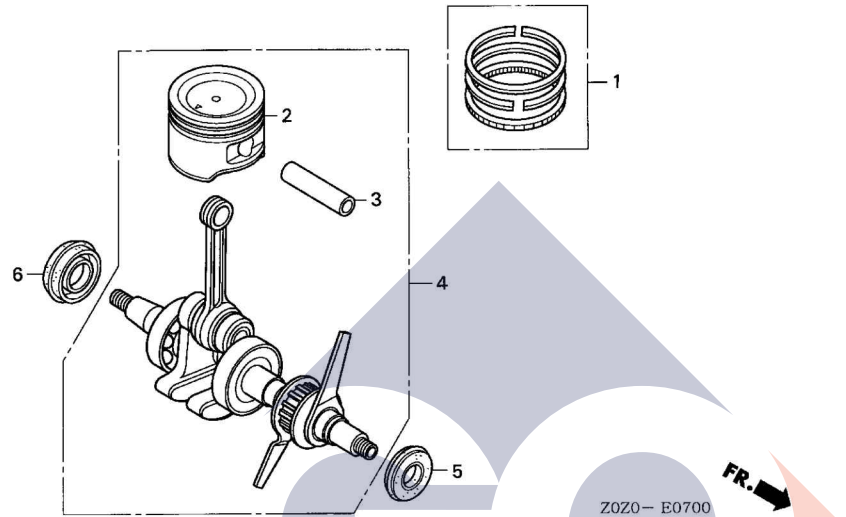

Service item	F.R.T.
CRANKSHAFT COMP.	1.2
.OIL SEAL, 10X20X5	
.OIL SEAL, 15X25X6	
PIN, PISTON	1.3
.RING SET, PISTON	
PISTON	1.4

Ref. No.	Part No.	Description	Reqd. QTY		Serial No.	Parts catalogue code
			GX	35		
1	13010-ZM5-000	RING SET, PISTON	1			
2	13101-Z0Z-000	PISTON	1			
3	13111-ZM5-000	PIN, PISTON	1			
4	13310-Z0Z-000	CRANKSHAFT COMP.	1			
5	91212-Z0H-003	OIL SEAL, 10X20X5	1			
6	91214-ZM3-003	OIL SEAL, 15X25X6	1			

2

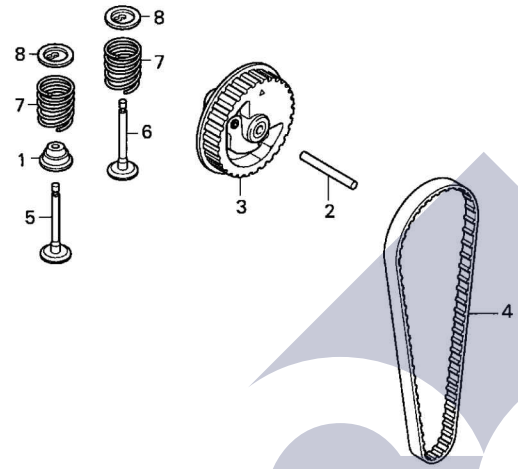

Service item	F.R.T.
PULLEY COMP., CAMSHAFT	0.4
BELT, TIMING	1.2
SEAL, VALVE STEM	1.3
.VALVE (ADD 0.1 FOR EACH.)	

Z0Z0-E1000

Ref. No.	Part No.	Description	Reqd. QTY		Serial No.	Parts catalogue code
			GX	35		
1	12209-ZOH-003	SEAL, VALVE STEM	1			
2	14126-ZOZ-003	ROLLER, 4X31.8	1			
3	14320-ZOZ-000	PULLEY COMP., CAMSHAFT	1			
4	14400-ZOZ-003	BELT, TIMING (76ZU7 G-300) ..	1			
5	14711-ZOZ-000	VALVE, IN.	1			
6	14721-ZOZ-000	VALVE, EX.	1			
7	14751-ZOZ-000	SPRING, VALVE	2			
8	14771-ZOH-000	RETAINER, VALVE SPRING	2			

goind.com.au

2

E-11

RECOIL STARTER

C 5

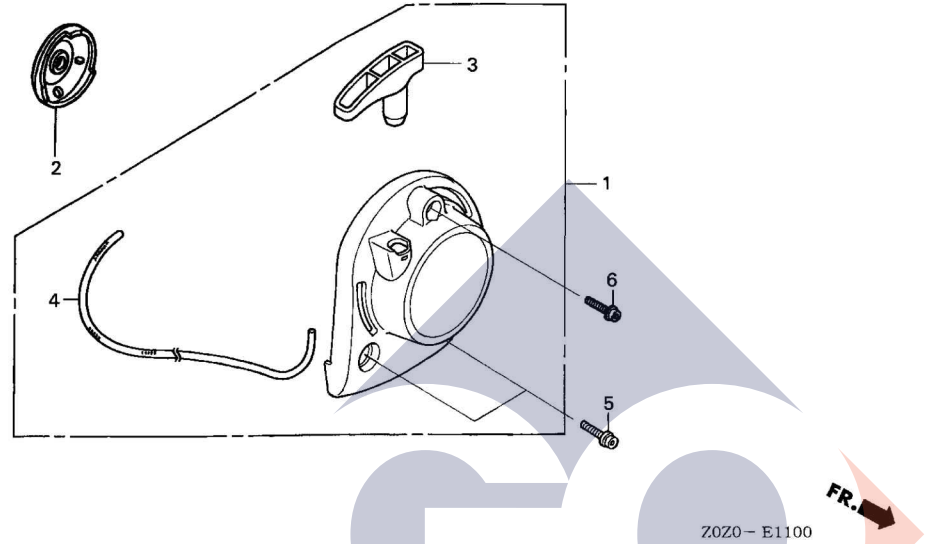

Service item	F.R.T.
STARTER ASSY., RECOIL	0.2
PULLEY, RECOIL STARTER	0.3
.ROPE, RECOIL STARTER	

Ref. No.	Part No.	Description	Reqd. QTY		Serial No.	Parts catalogue code
			GX	35		
1	28400-Z0Z-003	STARTER ASSY., RECOIL	1			
2	28451-Z0H-003	PULLEY, RECOIL STARTER	1			
3	28461-ZM3-003	KNOB, RECOIL STARTER	1			
4	28462-ZM3-003	ROPE, RECOIL STARTER	1			
5	90018-Z0H-003	BOLT, SOCKET, 5X16	2		----- SAU,SA2,SC2,SD,SE,SJ	
6	90018-Z0H-003	BOLT, SOCKET, 5X16	1			

2

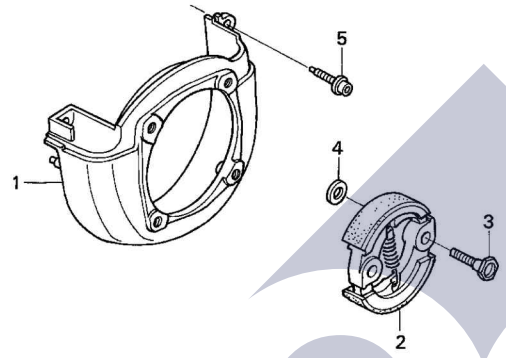

Z020-- E1200

Service item	F.R.T.
COVER, FAN	0.1
CLUTCH ASSY.	0.3

Ref. No.	Part No.	Description	Reqd. QTY		Serial No.	Parts catalogue code
			GX	35		
1	19611-Z0Z-000	COVER, FAN	1			
2	22000-ZM5-003	CLUTCH ASSY.	1			
3	22253-ZM5-003	BOLT, CLUTCH (8MM)	2			
4	22254-ZM5-003	WASHER, CLUTCH (8X17)	2			
5	90009-Z0H-003	BOLT, SOCKET, 5X20	3			

goind.com.au

E-14

CARBURETOR

C 7

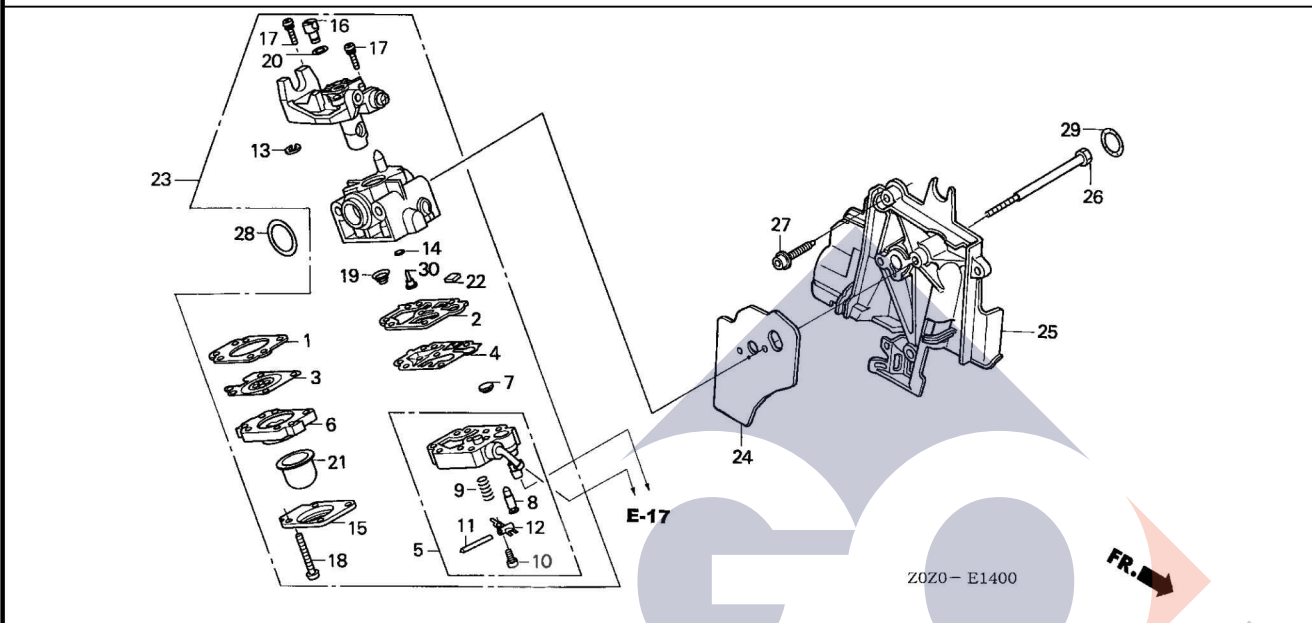

Service item	F.R.T.
O-RING, 14.8X2.4	0.1
CARBURETOR ASSY.	0.2
.SHROUD	
PUMP, PRIMER	0.3
BODY ASSY., PUMP	0.4
.JET	
.VALVE, INLET NEEDLE	

Ref. No.	Part No.	Description	Reqd. QTY	Serial No.	Parts catalogue code
			GX 35		
1	16010-ZM3-004	GASKET, METERING DIAPHRAGM ..	1		
2	16011-ZOH-003	GASKET, PUMP	1		
3	16013-ZOH-003	DIAPHRAGM ASSY., METERING ...	1		
4	16014-ZM3-004	DIAPHRAGM, PUMP	1		
5	16015-ZOH-003	BODY ASSY., PUMP	1		
6	16017-ZM3-004	BODY ASSY., AIR PURGE	1		
7	16018-ZM3-802	SCREEN, INLET	1		
8	16019-ZM3-004	VALVE, INLET NEEDLE	1		
9	16020-ZM3-004	SPRING, METERING LEVER	1		
10	16021-ZM3-004	SCREW, METERING LEVER PIN ...	1		
11	16022-ZM3-004	PIN, METERING LEVER	1		
12	16023-ZM3-004	LEVER, METERING	1		
13	16024-ZOH-003	RING, RETAINING	1		
14	16025-ZM3-004	O-RING	1		
15	16026-ZM3-004	COVER, PRIMER PUMP	1		
16	16027-ZM3-004	SWIVEL	1		
17	16028-ZM3-004	SCREW, THROTTLE COLLAR	2		
18	16029-ZM3-004	SCREW, PUMP COVER	4		
19	16030-ZM3-004	SPRING, PUMP	1		
20	16031-ZM3-004	WASHER	1		
21	16032-ZM3-004	PUMP, PRIMER	1		
22	16035-ZM3-802	FILTER, FUEL INLET	1		
23	16100-Z0Z-004	CARBURETOR ASSY. (WYB 16A) ..	1	-----	SAT, SA2, SCT, SC2
	16100-Z0Z-802	CARBURETOR ASSY. (WYB 15A) ..	1	-----	SAU, SAUT, SUT
	16100-Z0Z-812	CARBURETOR ASSY. (WYB 14A) ..	1	-----	SD, SDT, SE, SET, SJ, SJT

2

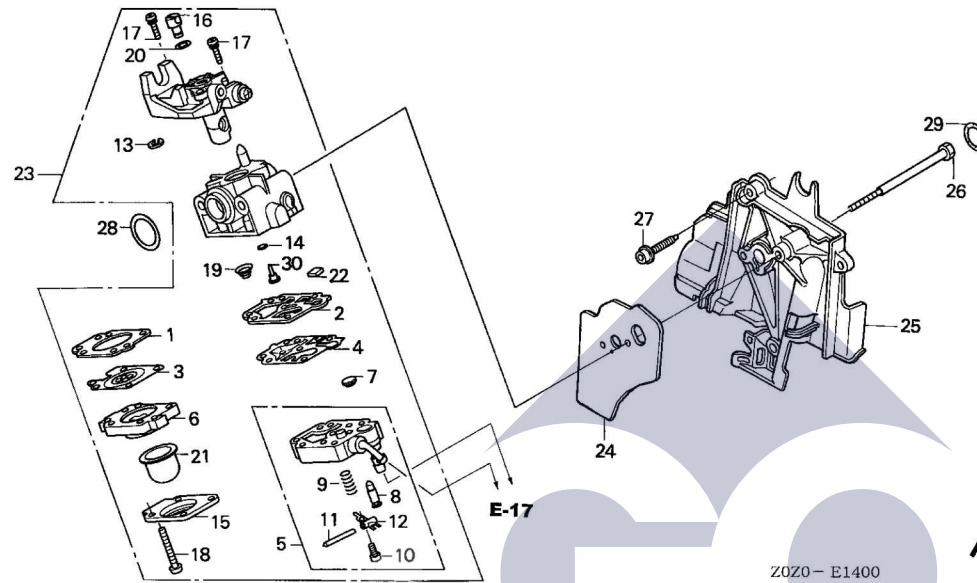

Z0Z0 - E1400



Ref. No.	Part No.	Description	Reqd. QTY		Serial No.	Parts catalogue code
			GX	35		
24	16221-Z0Z-000	PACKING, CARBURETOR	1			
25	19631-Z0Z-000	SHROUD	1			
26	90014-Z0H-003	BOLT, 5X53	2			
27	90018-Z0H-003	BOLT, SOCKET, 5X16	2			
28	91301-ZM3-000	O-RING, 14.8X2.4	1			
29	91308-Z0H-003	O-RING, 12.3X2.4	1			
30	99101-ZM5-0350	JET (#35)	(1)		SAT, SA2, SCT, SC2, SD, SDT, SE, SET, SJ, SJT	
	99101-Z0Z-0360	JET (#36)	(1)			
	99101-Z0Z-0370	JET (#37)	1		SAT, SA2, SCT, SC2, SD, SDT, SE, SET, SJ, SJT	
	99101-Z0Z-0380	JET (#38)	(1)		SAU, SAUT, SUT	
			1		SAU, SAUT, SUT	

E-15

AIR CLEANER

C 9

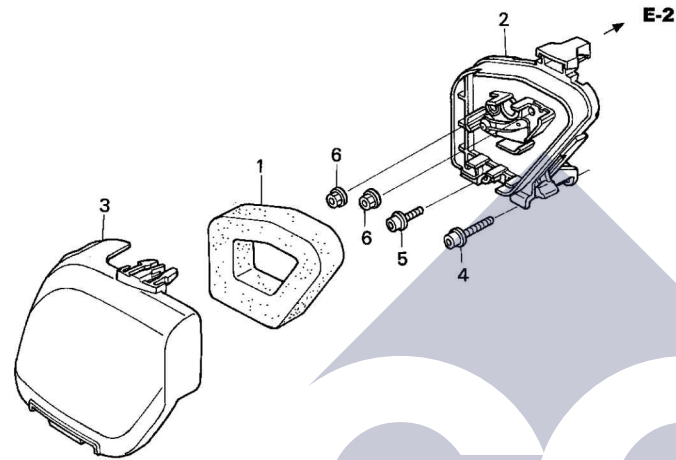

Service item	F.R.T.
CASE COMP., AIR CLEANER	0.1
.ELEMENT, AIR CLEANER	

Ref. No.	Part No.	Description	Reqd. QTY		Serial No.	Parts catalogue code
			GX	35		
1	17211-Z0Z-000	ELEMENT, AIR CLEANER	1			
2	17220-Z0Z-000	CASE COMP., AIR CLEANER	1			
3	17231-Z0Z-000	COVER, AIR CLEANER	1			
4	90009-Z0Z-003	BOLT, SOCKET, 5X25	1			
5	90018-Z0H-003	BOLT, SOCKET, 5X16	1			
6	94050-05000	NUT, FLANGE, 5MM	2			

2

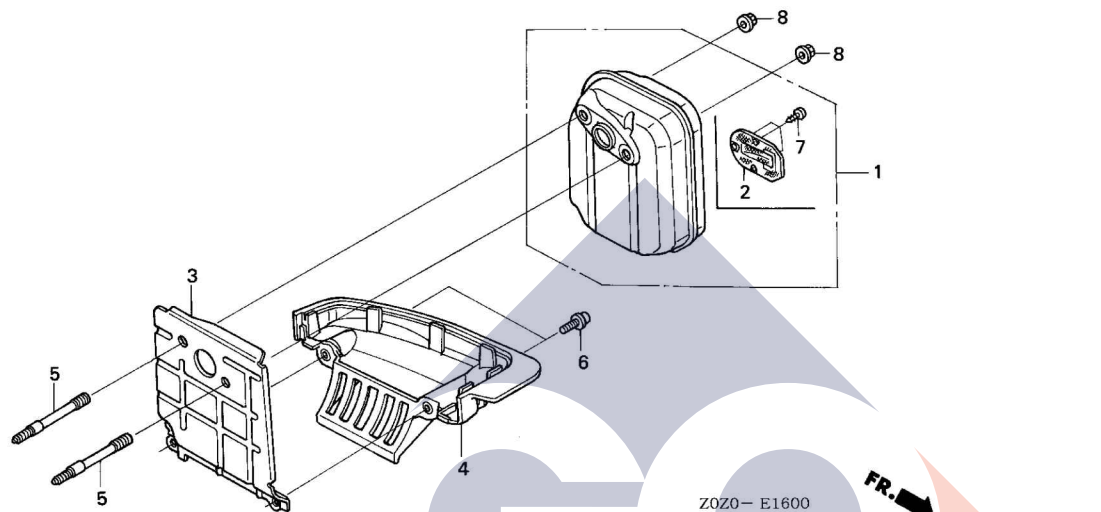

Service item	F.R.T.
ARRESTER COMP., SPARK	0.1
.GUIDE COMP., UNDER AIR	
.GUIDE, AIR	
.MUFFLER COMP.	

Ref. No.	Part No.	Description	Reqd. QTY		Serial No.	Parts catalogue code
			GX	35		
1	18310-Z0Z-000	MUFFLER COMP.	1		SD,SDT,SE,SET,SJ,SJT	
	18310-Z0Z-800	1		SAT,SAU,SAUT,SA2,SCT,SC2,SUT	
2	18350-Z0Z-800	ARRESTER COMP., SPARK	1		SAT,SAU,SAUT,SA2,SCT,SC2,SUT	
3	18515-Z0Z-300	GUIDE, AIR	1			
4	18518-Z0Z-000	GUIDE COMP., UNDER AIR	1			
5	90001-Z0Z-003	BOLT, STUD, 2,5X45.5	2			
6	90018-Z0H-003	BOLT, SOCKET, 5X16	2			
7	90055-ZE1-000	SCREW, TAPPING, 4X6	3		SAT,SAU,SAUT,SA2,SCT,SC2,SUT	
8	90136-SM4-901	NUT, SELF-LOCK, 5MM	2			

gond.com.ar

E-17

FUEL TANK

C11

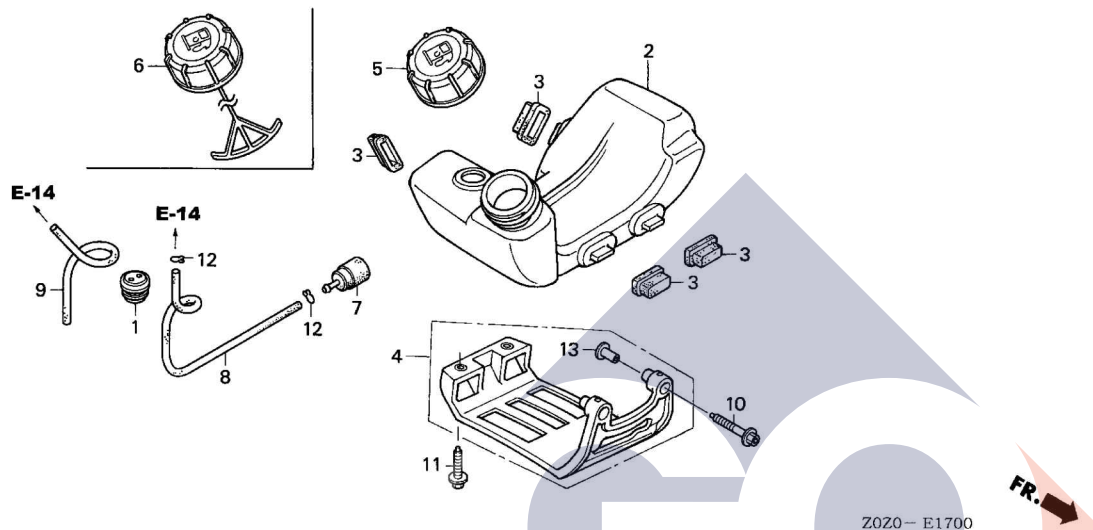

Service item	F.R.T.
FILTER, FUEL	0.2
.GUARD, TANK	
.TANK, FUEL	
.TUBE, FUEL RETURN	
.TUBE, FUEL TANK	

Z020 - E1700

Ref. No.	Part No.	Description	Reqd. QTY		Serial No.	Parts catalogue code
			GX	35		
1	17504-ZM3-003	GROMMET, FUEL TUBE	1			
2	17511-Z02-003	TANK, FUEL	1			
3	17533-Z0H-000	RUBBER, TANK MOUNTING	4			
4	17555-Z0Z-000	GUARD, TANK	1		SAT, SAUT, SCT, SDT, SET, SJT, SUT	
5	17620-ZM3-043	CAP ASSY., FUEL TANK	1		SAT, SAU, SAUT, SAZ, SCT, SC2, SD, SDT, SJ, SJT, SUT	
6	17620-ZM3-815	CAP ASSY., FUEL TANK	1		SE, SET	
7	17672-ZM3-003	FILTER, FUEL	1			
8	17701-Z0Z-000	TUBE, FUEL TANK	1			
9	17702-Z0Z-000	TUBE, FUEL RETURN	1			
10	90010-Z0H-003	BOLT, SOCKET, 5X30	2		SAT, SAUT, SCT, SDT, SET, SJT, SUT	
11	90018-Z0H-003	BOLT, SOCKET, 5X16	2		SAT, SAUT, SCT, SDT, SET, SJT, SUT	
12	91401-ZM3-003	CLIP, TUBE	2			
13	91501-Z0H-000	COLLAR, TANK GUARD	2		SAT, SAUT, SCT, SDT, SET, SJT, SUT	

2

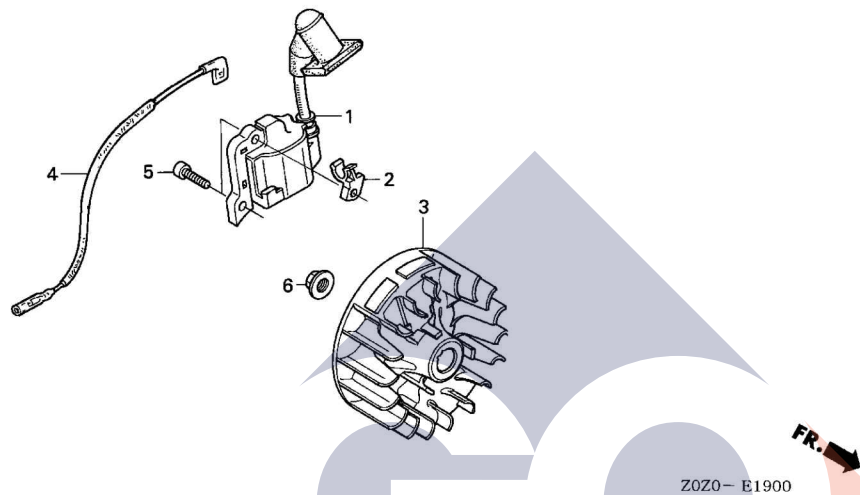

Service item	F.R.T.
CORD, STOP SWITCH	0.1
COIL ASSY., IGNITION	0.2
FLYWHEEL COMP.	0.4

2

Ref. No.	Part No.	Description	Reqd. QTY		Serial No.	Parts catalogue code
			GX	35		
1	30500-Z0Z-003	COIL ASSY., IGNITION	1			
2	30522-Z0Z-000	CLIP, HIGH TENSION CORD	1			
3	31110-Z0Z-003	FLYWHEEL COMP.	1			
4	32195-Z0Z-000	CORD, STOP SWITCH	1			
5	90012-Z0H-005	BOLT, SOCKET, 4X14	2			
6	94050-08000	NUT, FLANGE, 8MM	1			

E-27

TOP COVER

C13

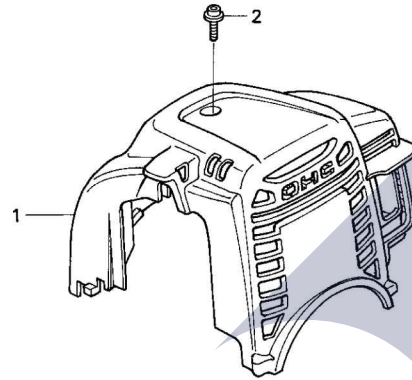

Z0Z0 - E2700



Service item	F.R.T.
COVER COMP., TOP	0.1

Ref. No.	Part No.	Description	Reqd. QTY	Serial No.	Parts catalogue code
			GX 35		
1	19720-Z0Z-000ZA	COVER COMP., TOP *R280*.....POWER RED	1		
2	90015-Z0H-003	BOLT, TOP COVER	1		

2

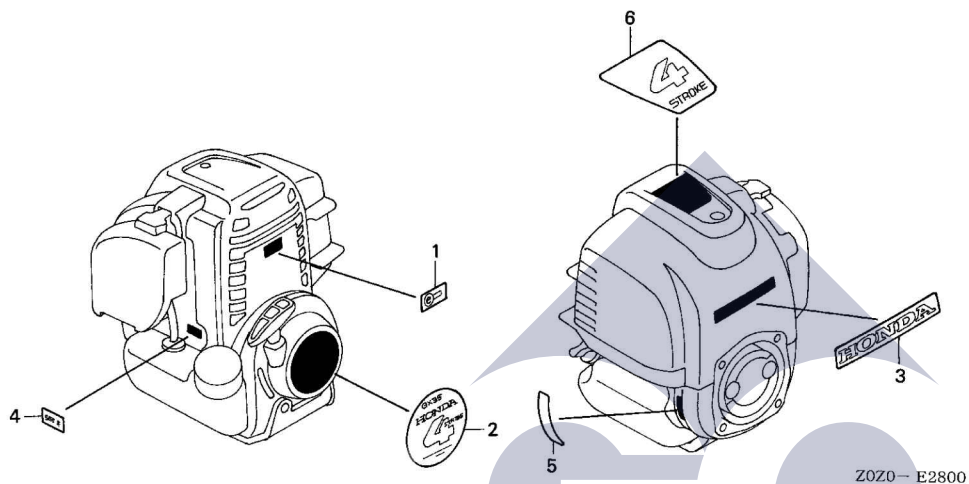

Service item F.R.T.
NOT INFORMATION

Ref. No.	Part No.	Description	Reqd. QTY	Serial No.	Parts catalogue code
			GX 35		
1	87135-ZE2-020	LABEL, E-SPEC (15.5X27.5) ...	1	-----	SAU,SAUT,SD,SDT,SE,SET,SJ,SJT,SUT
2	87521-ZOZ-000	MARK, EMBLEM	1	-----	
3	87531-ZOZ-000	MARK, HONDA	1	-----	
4	87601-ZOH-800	MARK, TYPE (SJ)	1	-----	SJ
	87601-ZOH-810	MARK, TYPE (SJT)	1	-----	SJT
	87601-ZOH-820	MARK, TYPE (SC2)	1	-----	SC2
	87601-ZOH-830	MARK, TYPE (SE)	1	-----	SE
	87601-ZOH-840	MARK, TYPE (SET)	1	-----	SET
	87601-ZOH-850	MARK, TYPE (SA2)	1	-----	SA2
	87601-ZOH-860	MARK, TYPE (SAT)	1	-----	SAT
	87601-ZOH-870	MARK, TYPE (SAU)	1	-----	SAU
	87601-ZOH-880	MARK, TYPE (SAUT)	1	-----	SAUT
	87601-ZOH-890	MARK, TYPE (SD)	1	-----	SD
	87601-ZOH-900	MARK, TYPE (SDT)	1	-----	SDT
	87601-ZOH-950	MARK, TYPE (SUT)	1	-----	SUT
	87601-ZOZ-800	MARK, TYPE (SCT)	1	-----	SCT
5	87637-ZM3-800	MARK (C-TICK)	1	-----	SAU,SAUT,SUT
6	87660-ZOZ-J00	MARK (4-STROKE)	1	-----	SUT
	87660-ZOZ-000	1	-----	SAT,SAU,SAUT,SA2,SCT,SC2,SD,SDT,SE,SET,SJ,SJT

Service item F.R.T.
NOT INFORMATION

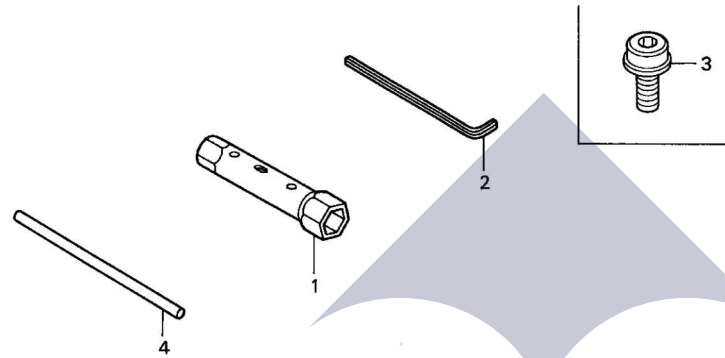

Z0Z0 - E2900

Ref. No.	Part No.	Description	Reqd. QTY		Serial No.	Parts catalogue code
			GX	35		
1	89216-045-010	WRENCH, SPARK PLUG	(1)			
2	89221-KW3-000	WRENCH, HEX., 4MM	(1)			
3	90011-Z0H-811	BOLT, SOCKET, 5X9	1		----- SUT	
			(1)		----- SAT,SAU,SAUT,SA2,SCT,SC2,SD,SDT,SE,SET,SJ,SJT	
4	99005-01000	BAR A, HANDLE	(1)			

PART NO. INDEX

D 1

Part Number	Address	Page	Ref.	Part Number	Address	Page	Ref.	Part Number	Address	Page	Ref.	Part Number	Address	Page	Ref.	Part Number	Address	Page	Ref.
10000				16030-ZM3-004	C7	19	19	31914-ZOH-003	C1	13	13	90019-ZOH-003	C1	13	19				
10100-ZOZ-405	C1	13	1	16031-ZM3-004	C7	19	20	31914-ZOH-801	C1	13	13	90055-ZE1-000	C10	22	7				
12000				16032-ZM3-004	C7	19	21	31915-ZOH-003	C1	13	13	90136-SM4-901	C10	22	8				
12209-ZOH-003	C4	16	1	16035-ZM3-802	C7	19	22	31915-ZOH-801	C1	13	13	90206-ZM3-000	C1	13	20				
12310-ZOZ-000	C1	13	2	16100-ZOZ-004	C7	19	23	31916-ZOH-003	C1	13	13	91000							
12312-ZOZ-300	C1	13	3	16100-ZOZ-802	C7	19	23	31916-ZOH-801	C1	13	13	91212-ZOH-003	C3	15	5				
12314-ZOH-300	C1	13	4	16100-ZOZ-812	C7	19	23	32000				91214-ZM3-003	C3	15	6				
12367-ZOH-000	C1	13	5	16221-ZOZ-000	C8	20	24	32195-ZOZ-000	C12	24	4	91301-ZM3-000	C8	20	28				
13000				17000				87000				91308-ZOH-003	C8	20	29				
13010-ZM5-000	C3	15	1	17211-ZOZ-000	C9	21	1	87135-ZE2-020	C14	26	1	91401-ZM3-003	C11	23	12				
13101-ZOZ-000	C3	15	2	17220-ZOZ-000	C9	21	2	87521-ZOZ-000	C14	26	2	91501-ZOH-000	C11	23	13				
13111-ZM5-000	C3	15	3	17231-ZOZ-000	C9	21	3	87531-ZOZ-000	C14	26	3	93000							
13310-ZOZ-000	C3	15	4	17504-ZM3-003	C11	23	1	87601-ZOH-800	C14	26	4	93500-03005-0A	C2	14	21				
14000				17511-ZOZ-003	C11	23	2	87601-ZOH-810	C14	26	4	94000							
14126-ZOZ-003	C4	16	2	17533-ZOH-000	C11	23	3	87601-ZOH-820	C14	26	4	94050-05000	C9	21	6				
14320-ZOZ-000	C4	16	3	17555-ZOZ-000	C11	23	4	87601-ZOH-830	C14	26	4	94050-08000	C12	24	6				
14400-ZOZ-003	C4	16	4	17620-ZM3-043	C11	23	5	87601-ZOH-840	C14	26	4	94305-40102	C2	14	22				
14711-ZOZ-000	C4	16	5	17620-ZM3-815	C11	23	6	87601-ZOH-850	C14	26	4	95000							
14721-ZOZ-000	C4	16	6	17672-ZM3-003	C11	23	7	87601-ZOH-860	C14	26	4	95002-41200-08	C2	14	23				
14751-ZOZ-000	C4	16	7	17701-ZOZ-000	C11	23	8	87601-ZOH-870	C14	26	4	95002-41300-04	C2	14	24				
14771-ZOH-000	C4	16	8	17702-ZOZ-000	C11	23	9	87601-ZOH-880	C14	26	4	99000							
15000				18000				87601-ZOH-890	C14	26	4	99005-01000	C15	27	4				
15422-ZOZ-000	C1	13	6	18310-ZOZ-000	C10	22	1	87601-ZOH-900	C14	26	4	99101-ZOZ-0360	C8	20	30				
15510-ZOH-000	C1	13	7	18310-ZOZ-800	C10	22	1	87601-ZOH-950	C14	26	4	99101-ZOZ-0370	C8	20	30				
15571-ZM3-003	C1	13	8	18350-ZOZ-800	C10	22	2	87601-ZOZ-800	C14	26	4	99101-ZOZ-0380	C8	20	30				
15572-ZOH-000	C1	13	9	18515-ZOZ-300	C10	22	3	87637-ZM3-800	C14	26	5	99101-ZM5-0350	C8	20	30				
15600-ZM3-003	C1	13	10	18518-ZOZ-000	C10	22	4	87660-ZOZ-000	C14	26	6								
15625-ZE1-003	C1	13	11	19000				87660-ZOZ-J00	C14	26	6								
15721-ZOZ-000	C1	13	12	19611-ZOZ-000	C6	18	1	89000											
16000				19631-ZOZ-000	C8	20	25	89216-045-010	C15	27	1								
16010-ZM3-004	C7	19	1	19720-ZOZ-000ZA	C13	25	1	89221-KW3-000	C15	27	2								
16011-ZOH-003	C7	19	2	22000				90000											
16013-ZOH-003	C7	19	3	22000-ZM5-003	C6	18	2	90001-ZOZ-003	C10	22	5								
16014-ZM3-004	C7	19	4	22253-ZM5-003	C6	18	3	90009-ZOH-003	C1	13	14								
16015-ZOH-003	C7	19	5	22254-ZM5-003	C6	18	4	90009-ZOZ-003	C9	21	4								
16017-ZM3-004	C7	19	6	28000				90010-ZOH-003	C11	23	10								
16018-ZM3-802	C7	19	7	28400-ZOZ-003	C5	17	1	90010-ZOZ-003	C1	13	15								
16019-ZM3-004	C7	19	8	28451-ZOH-003	C5	17	2	90011-ZOH-811	C15	27	3								
16020-ZM3-004	C7	19	9	28461-ZM3-003	C5	17	3	90012-ZOH-005	C12	24	5								
16021-ZM3-004	C7	19	10	28462-ZM3-003	C5	17	4	90013-ZOH-004	C1	13	16								
16022-ZM3-004	C7	19	11	30000				90013-ZOZ-003	C1	13	17								
16023-ZM3-004	C7	19	12	30500-ZOZ-003	C12	24	1	90014-ZOH-003	C8	20	26								
16024-ZOH-003	C7	19	13	30522-ZOZ-000	C12	24	2	90015-ZOH-003	C13	25	2								
16025-ZM3-004	C7	19	14	31000				90017-ZOH-000	C1	13	18								
16026-ZM3-004	C7	19	15	31110-ZOZ-003	C12	24	3	90018-ZOH-003	C5	17	5								
16027-ZM3-004	C7	19	16								6								
16028-ZM3-004	C7	19	17								6								
16029-ZM3-004	C7	19	18								6								
											11								

PART NAME INDEX

E 1

Part name	Address	Page	Ref.	Part name	Address	Page	Ref.	Part name	Address	Page	Ref.
[A]				[E]				[P]			
ARRESTER COMP., SPARK	C10	22	2	ELEMENT, AIR CLEANER	C9	21	1	PACKING, CARBURETOR	C8	20	24
[B]				[F]				PACKING, OIL FILLER CAP	C1	13	11
BAR A, HANDLE	C15	27	4	FILTER, BREATHER	C1	13	5	PIN, METERING LEVER	C7	19	11
BELT, TIMING	C4	16	4	FILTER, FUEL	C11	23	7	PIN, PISTON	C3	15	3
BODY ASSY., AIR PURGE	C7	19	6	FILTER, FUEL INLET	C7	19	22	PIN, SPRING, 4X10	C2	14	22
BODY ASSY., PUMP	C7	19	5	FLYWHEEL COMP.	C12	24	3	PISTON	C3	15	2
BOLT, 5X53	C8	20	26	[G]				PLATE ASSY., OIL OUTLET VALVE ..	C1	13	7
BOLT, CLUTCH	C6	18	3	GASKET, METERING DIAPHRAGM	C7	19	1	PLATE, STOPPER	C1	13	9
BOLT, SOCKET, 4X14	C12	24	5	GASKET, PUMP	C7	19	2	PLUG, SPARK	C1	13	13
BOLT, SOCKET, 5X12	C1	13	19	GROMMET, FUEL TUBE	C11	23	1	PULLEY COMP., CAMSHAFT	C4	16	3
BOLT, SOCKET, 5X16	C5	17	5	GROMMET, HEAD COVER	C1	13	4	PULLEY, RECOIL STARTER	C5	17	2
	C8	20	27	GUARD, TANK	C11	23	4	PUMP, PRIMER	C7	19	21
	C9	21	5	GUIDE COMP., UNDER AIR	C10	22	4	[R]			
	C10	22	6	GUIDE, AIR	C10	22	3	RETAINER, VALVE SPRING	C4	16	8
	C11	23	11	[J]				RING SET, PISTON	C3	15	1
BOLT, SOCKET, 5X20	C1	13	14	JET	C8	20	30	RING, RETAINING	C7	19	13
	C6	18	5	[K]				ROLLER, 4X31.8	C4	16	2
BOLT, SOCKET, 5X25	C9	21	4	KNOB, RECOIL STARTER	C5	17	3	ROPE, RECOIL STARTER	C5	17	4
BOLT, SOCKET, 5X30	C11	23	10	[L]				RUBBER, TANK MOUNTING	C11	23	3
BOLT, SOCKET, 5X32	C1	13	15	LABEL, E-SPEC	C14	26	1	[S]			
BOLT, SOCKET, 5X9	C15	27	3	LEVER, METERING	C7	19	12	SCREEN, INLET	C7	19	7
BOLT, STUD, 2,5X45.5	C10	22	5	[M]				SCREW, METERING LEVER PIN	C7	19	10
BOLT, TOP COVER	C13	25	2	MARK	C14	26	5	SCREW, PAN, 3X5	C2	14	21
[C]				MARK, EMBLEM	C14	26	2	SCREW, PAN, 4X8	C1	13	16
CAP ASSY., FUEL TANK	C11	23	5	MARK, HONDA	C14	26	3	SCREW, PUMP COVER	C7	19	18
			6	MARK, TYPE	C14	26	4	SCREW, TAPPET ADJUSTING	C1	13	18
CAP ASSY., OIL FILLER	C1	13	10	MUFFLER COMP.	C10	22	1	SCREW, TAPPING, 4X6	C10	22	7
CARBURETOR ASSY.	C7	19	23	[N]				SCREW, THROTTLE COLLAR	C7	19	17
CASE COMP., AIR CLEANER	C9	21	2	NUT, FLANGE, 5MM	C9	21	6	SEAL, HEAD COVER	C1	13	3
CLAMP, TUBE	C2	14	23	NUT, FLANGE, 8MM	C12	24	6	SEAL, VALVE STEM	C4	16	1
			24	NUT, SELF-LOCK, 5MM	C10	22	8	SHROUD	C8	20	25
CLIP, HIGH TENSION CORD	C12	24	2	NUT, TAPPET ADJUSTING	C1	13	20	SPRING, METERING LEVER	C7	19	9
CLIP, TUBE	C11	23	12	[O]				SPRING, PUMP	C7	19	19
CLUTCH ASSY.	C6	18	2	OIL SEAL, 10X20X5	C3	15	5	SPRING, VALVE	C4	16	7
COIL ASSY., IGNITION	C12	24	1	OIL SEAL, 15X25X6	C3	15	6	STARTER ASSY., RECOIL	C5	17	1
COLLAR, TANK GUARD	C11	23	13	O-RING	C7	19	14	SWIVEL	C7	19	16
CORD, STOP SWITCH	C12	24	4	O-RING, 12.3X2.4	C8	20	29	[T]			
COVER COMP., TOP	C13	25	1	O-RING, 14.8X2.4	C8	20	28	TANK, FUEL	C11	23	2
COVER, AIR CLEANER	C9	21	3	[P]				TUBE, BREATHER	C1	13	12
COVER, CYLINDER HEAD	C1	13	2	VALVE, EX.	C4	16	6	TUBE, FUEL RETURN	C11	23	9
COVER, FAN	C6	18	1	VALVE, INLET NEEDLE	C7	19	8	TUBE, FUEL TANK	C11	23	8
COVER, PRIMER PUMP	C7	19	15	VALVE, IN.	C4	16	5	TUBE, OIL	C1	13	6
CRANKCASE SET	C1	13	1	[Q]				[V]			
CRANKSHAFT COMP.	C3	15	4	OIL SEAL, 10X20X5	C3	15	5	VALVE, EX.	C4	16	6
[D]				OIL SEAL, 15X25X6	C3	15	6	VALVE, INLET NEEDLE	C7	19	8
DIAPHRAGM ASSY., METERING	C7	19	3	O-RING	C7	19	14	VALVE, IN.	C4	16	5
DIAPHRAGM, PUMP	C7	19	4	O-RING, 12.3X2.4	C8	20	29	VALVE, OIL OUTLET	C1	13	8
				O-RING, 14.8X2.4	C8	20	28	[W]			



PART NAME INDEX

E 2

Part name	Address	Page	Ref.	Part name	Address	Page	Ref.	Part name	Address	Page	Ref.
[W]											
WASHER	C7	19	20								
WASHER, CLUTCH	C6	18	4								
WRENCH, HEX., 4MM	C15	27	2								
WRENCH, SPARK PLUG	C15	27	1								

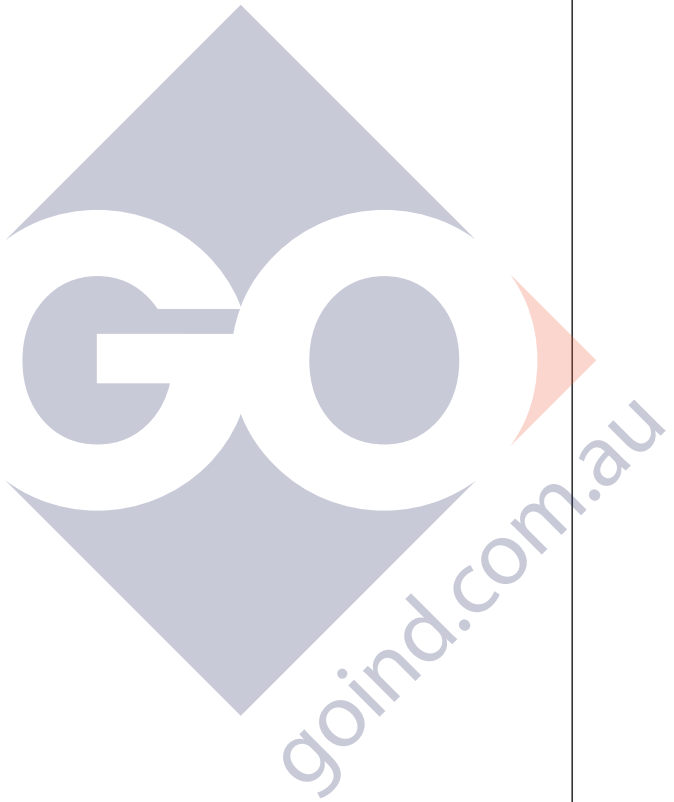

goind.com.au



1

FOREWORD INDEX

2

ENGINE GROUP

3

PART NUMBER INDEX

4

PART NAME INDEX









PARTS CATALOGUE NEWS

Honda Motor Co., Ltd. Service Division

PARTS CATALOGUE - CORRECTED

Printed in Japan

CODE NO.	BOOKLET TYPE	13Z0Z401
	MICRO-FICHE	13Z0Z4EA/FA
PARTS CATALOGUE NEWS	GX35	
NEWS NO.	001	

Block No.	Ref. No.	Note	Part No.	Description	Reqd. QTY	Serial No.	Parts catalogue code
					GX 35		

E-11 RECOIL STARTER

Service Item	F.R.T.
REEL, RECOIL STARTER.....	0.3
SPRING, RECOIL STARTER	

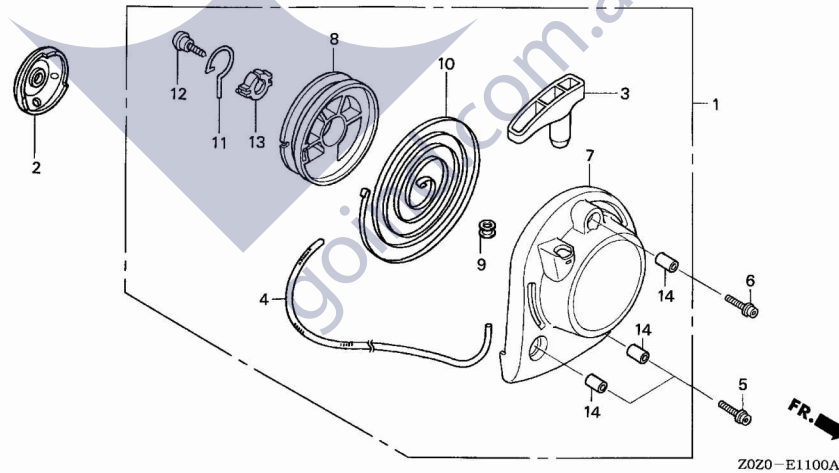

E-11	7	D	28414-Z0Z-000	CASE, RECOIL STARTER	1		
------	---	---	---------------	----------------------------	---	--	--

NOTE A:PART NO. CHANGE D:NEWLY PROVIDED E:PART NO.DELETION K:REQUIRED NO. CORRECTION L:APPLICATION SERIAL NO. CORRECTION
T:APPLICATION CORRECTION Z:REMARKS CHANGE

PARTS CATALOGUE NEWS

BOOKNo. : 13ZOZ401

Block No.	Ref. No.	Note	Part No.	Description	Reqd. QTY	Serial No.	Parts catalogue code
	8	D	28421-ZM3-003	REEL, RECOIL STARTER	1		
	9	D	28433-ZM3-003	GUIDE, ROPE	1		
	10	D	28442-ZM3-003	SPRING, RECOIL STARTER	1		
	11	D	28459-ZOH-003	ARM, SWING	1		
	12	D	90012-ZM3-003	SCREW, SETTING	1		
	13	D	91504-ZM3-003	COLLAR	1		
	14	D	91506-ZM3-000	COLLAR A, HEAD COVER	3		



NOTE A:PART NO. CHANGE D:NEWLY PROVIDED E:PART NO.DELETION K:REQUIRED NO. CORRECTION L:APPLICATION SERIAL NO. CORRECTION
T:APPLICATION CORRECTION Z:REMARKS CHANGE



PARTS CATALOGUE NEWS

Honda Motor Co., Ltd. Service Division

CODE NO.	BOOKLET TYPE	13Z0Z401
	MICRO- FICHE	13Z0Z4EA/FA
PARTS CATALOGUE NEWS	GX35	
NEWS NO.	002	

Printed in Japan

GX35-SEGT TYPE sales parts information

NOTE: This Parts Catalogue News explains only the parts of the different model that are produced to conform to addition of the GX35-SEGT type.

As for the parts not listed on this Parts Catalogue News, use the parts of the GX35-SET type.

Model	Type		Parts catalogue type	Applicable engine serial No.	Applicable carburetor identification No.
GX35	SET	Base model	SET	GCACM-1000001~	WYB14 A
	SEGT	Additional model	SEGT	GCACM-1100001~	WYB16 A

PARTS CATALOGUE NEWS

BOOKNo. :13ZOZ401

Block No.	Ref. No.	Part No.	Description	Reqd. QTY	Base Part No.	Parts catalogue code
				GX 35		
E-11	5	90018-Z0H-003	BOLT, SOCKET, 5X16	2		
E-14	11	16022-ZM3-014	PIN, METERING LEVER	1	16022-ZM3-004	
	23	16100-Z0Z-014	CARBURETOR ASSY. (WYB 16A) ...	1	16100-Z0Z-812	
	30		JET (#35)	(0)	99101-ZM5-0350	
E-17	6	17620-ZM3-816	CAP ASSY., FUEL TANK	1	17620-ZM3-815	
E-27	1	19720-Z0Z-000ZB	COVER COMP., TOP *T92*..... STIGA YELLOW	1	19720-Z0Z-000ZA	
E-28	3		MARK, HONDA	0	87531-Z0Z-000	
	4	87601-Z0H-V10	MARK, TYPE (SEGT)	1	87601-Z0H-840	

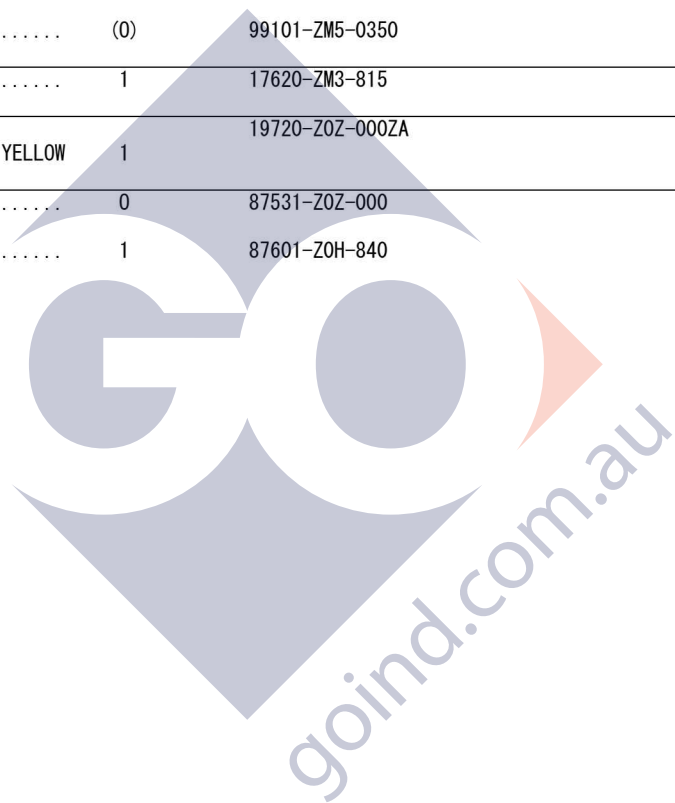

NOTE A:PART NO. CHANGE D:NEWLY PROVIDED E:PART NO.DELETION K:REQUIRED NO. CORRECTION L:APPLICATION SERIAL NO. CORRECTION
T:APPLICATION CORRECTION Z:REMARKS CHANGE



PARTS CATALOGUE NEWS

Honda Motor Co., Ltd. Service Division

PARTS CATALOGUE - CORRECTED

Printed in Japan

CODE NO.	BOOKLET TYPE	13Z0Z401
	MICRO-FICHE	13Z0Z4EA/FA
PARTS CATALOGUE NEWS	GX35	
NEWS NO.	003	

Block No.	Ref. No.	Note	Part No.	Description	Reqd. QTY	Serial No.	Parts catalogue code
E-14	23	T	16100-Z0Z-812	CARBURETOR ASSY. (WYB 14A) ...	1	-----	SD, SDT, SJ, SJT
		A	16100-Z0Z-004	CARBURETOR ASSY. (WYB 16A) ...	1	-----	SE, SET

NOTE A:PART NO. CHANGE D:NEWLY PROVIDED E:PART NO.DELETION K:REQUIRED NO. CORRECTION L:APPLICATION SERIAL NO. CORRECTION
T:APPLICATION CORRECTION Z:REMARKS CHANGE



PARTS CATALOGUE NEWS

Honda Motor Co., Ltd. Service Division

CODE NO.	BOOKLET TYPE	13Z0Z401
	MICRO-FICHE	13Z0Z4EA/FA
PARTS CATALOGUE NEWS	GX35	
NEWS NO.	004	

Printed in Japan

These types have been added into model GX35

As for the parts not listed on this Parts Catalogue News, use the parts of base type.

Model	Type	Parts catalogue type		Applicable engine serial No.
		Base type	Additional type	
GX35	SAT	SAT	SAT/A	GCACM-1100001~
	SAU	SAU	SAU/A	
	SAUT	SAUT	SAUT/A	
	SA2	SA2	SA2/A	

PARTS CATALOGUE NEWS

BOOKNo. : 13ZOZ401

Model	Type	Parts catalogue type		Applicable engine serial No.
		Base type	Additional type	
GX35	SCT	SCT	SCT/A	GCACM-1100001~
	SC2	SC2	SC2/A	
	SD	SD	SD/A	
	SDT	SDT	SDT/A	
	SE	SE	SE/A	
	SET	SET	SET/A	
	SJ	SJ	SJ/A	
	SJT	SJT	SJT/A	
	SUT	SUT	SUT/A	

NOTE A:PART NO. CHANGE D:NEWLY PROVIDED E:PART NO. DELETION K:REQUIRED NO. CORRECTION L:APPLICATION SERIAL NO. CORRECTION
T:APPLICATION CORRECTION Z:REMARKS CHANGE

PARTS CATALOGUE NEWS

BOOKNo. : 13ZOZ401

Block No.	Ref. No.	Part No.	Description	Reqd. QTY	Base Part No.	Parts catalogue code
				GX 35		
E-17	5	17620-ZM3-053	CAP ASSY., FUEL TANK	1	17620-ZM3-043	SAT/A, SAU/A, SAUT/A, SA2/A, SCT/A, SC2/A, SD/A, SDT/A, SJ/A, SJT/A, SUT/A
	6	17620-ZM3-816	CAP ASSY., FUEL TANK	1	17620-ZM3-815	SE/A, SET/A



NOTE A:PART NO. CHANGE D:NEWLY PROVIDED E:PART NO.DELETION K:REQUIRED NO. CORRECTION L:APPLICATION SERIAL NO. CORRECTION
T:APPLICATION CORRECTION Z:REMARKS CHANGE



PARTS CATALOGUE NEWS

Honda Motor Co., Ltd. Service Division

PARTS CATALOGUE - CORRECTED

Printed in Japan

CODE NO.	BOOKLET TYPE	13Z0Z401
	MICRO-FICHE	13Z0Z4EA/FA
PARTS CATALOGUE NEWS	GX35	
NEWS NO.	005	

Block No.	Ref. No.	Note	Part No.	Description	Reqd. QTY	Serial No.	Parts catalogue code
E-16	1		18310-Z0Z-000	MUFFLER COMP.	1		SD, SDT, SE, SET, SJ, SJT
					1	1116434	SD/A, SDT/A, SE/A, SEGT, SET/A, SJ/A, SJT/A
	A	18310-Z0Z-010	1	1116435	SD/A, SDT/A, SE/A, SEGT, SET/A, SJ/A, SJT/A	

NOTE A:PART NO. CHANGE D:NEWLY PROVIDED E:PART NO.DELETION K:REQUIRED NO. CORRECTION L:APPLICATION SERIAL NO. CORRECTION
T:APPLICATION CORRECTION Z:REMARKS CHANGE



PARTS CATALOGUE NEWS

Honda Motor Co., Ltd. Service Division

CODE NO.	BOOKLET TYPE	13Z0Z401
	MICRO-FICHE	13Z0Z4EA/FA
PARTS CATALOGUE NEWS	GX35	
NEWS NO.	006	

Printed in Japan

GX35-SDS,SJS TYPES sales parts information

NOTE: This Parts Catalogue News explains only the parts of the different model that are produced to conform to addition of the GX35-SDS,SJS types.

As for the parts not listed on this Parts Catalogue News, use the parts of the GX35-SD/A,SJ/A types.

Model	Type		Parts catalogue type	Applicable engine serial No.	Applicable carburetor identification No.
GX35	SD	Base model	SD/A	GCACM-1000001~	WYB 14A
	SDS	Additional model	SDS	GCACM-1100001~	
	SJ	Base model	SJ/A	GCACM-1000001~	
	SJS	Additional model	SJS	GCACM-1100001~	

PARTS CATALOGUE NEWS

BOOKNo. : 13ZOZ401

Block No.	Ref. No.	Part No.	Description	Reqd. QTY	Base Part No.	Parts catalogue code
-----------	----------	----------	-------------	-----------	---------------	----------------------

GX35

E-11 RECOIL STARTER

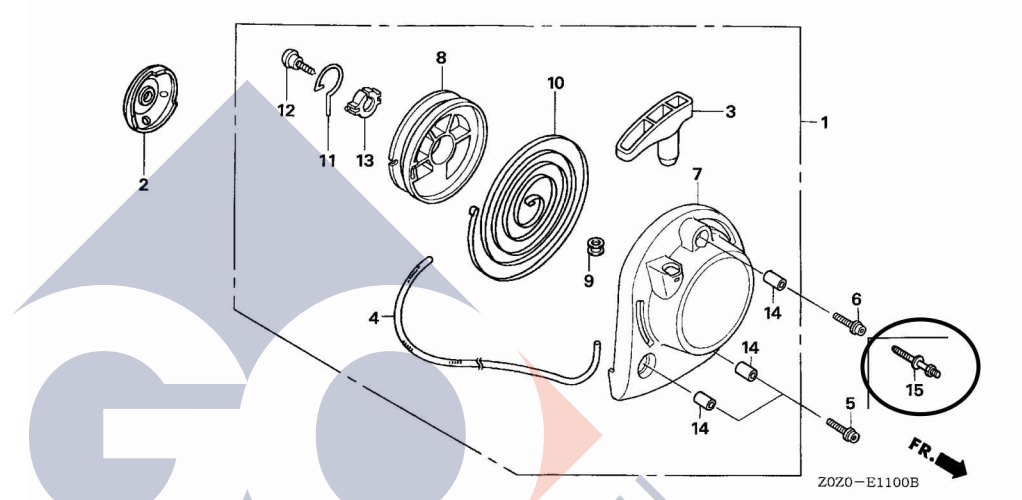

E-11	5		BOLT, SOCKET, 5X16	0	90018-Z0H-003	
	15	90043-Z0H-000	BOLT, STUD, B	2		

NOTE A:PART NO. CHANGE D:NEWLY PROVIDED E:PART NO.DELETION K:REQUIRED NO. CORRECTION L:APPLICATION SERIAL NO. CORRECTION
T:APPLICATION CORRECTION Z:REMARKS CHANGE

PARTS CATALOGUE NEWS

BOOKNo. : 13ZOZ401

Block No.	Ref. No.	Part No.	Description	Reqd. QTY	Base Part No.	Parts catalogue code
-----------	----------	----------	-------------	-----------	---------------	----------------------

GX35

E-12 FAN COVER/CLUTCH

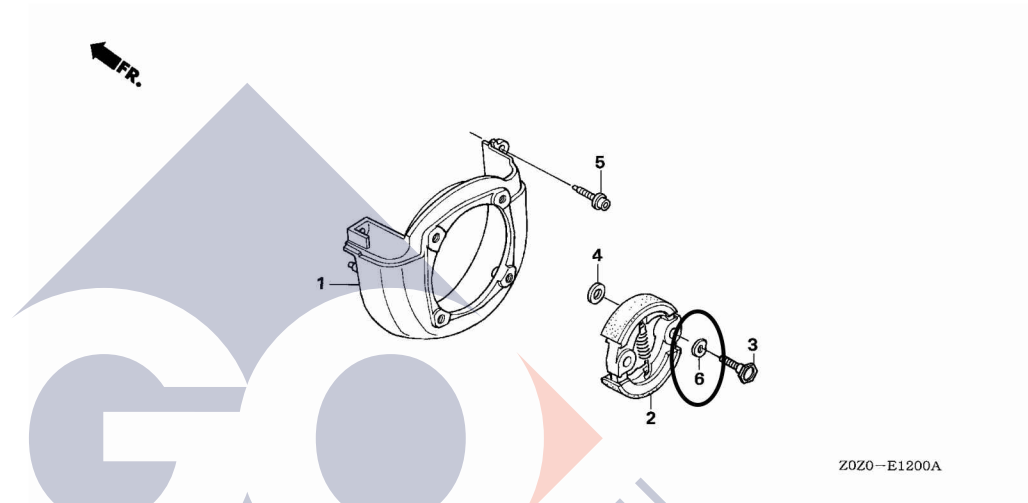

E-12	2	22000-ZOZ-003	CLUTCH ASSY.	1	22000-ZM5-003	
	3	22253-ZOZ-003	BOLT, CLUTCH (8MM)	2	22253-ZM5-003	
	6	22254-ZOZ-003	WASHER, WAVE (8MM)	2		
E-14	11	16022-ZM3-014	PIN, METERING LEVER	1	16022-ZM3-004	
	23	16100-ZOZ-813	CARBURETOR ASSY. (WYB 14A) ...	1	16100-ZOZ-812	
E-28	4	87601-ZOH-940	MARK, TYPE (SJS)	1	87601-ZOH-800	SJS
		87601-ZOZ-V20	MARK, TYPE (SDS)	1	87601-ZOH-890	SDS

NOTE A:PART NO. CHANGE D:NEWLY PROVIDED E:PART NO.DELETION K:REQUIRED NO. CORRECTION L:APPLICATION SERIAL NO. CORRECTION
T:APPLICATION CORRECTION Z:REMARKS CHANGE



PARTS CATALOGUE NEWS

Honda Motor Co., Ltd. Service Division

PARTS CATALOGUE - CORRECTED

Printed in Japan

CODE NO.	BOOKLET TYPE	13Z0Z401
	MICRO-FICHE	13Z0Z4EA/FA
PARTS CATALOGUE NEWS	GX35	
NEWS NO.	007	

Block No.	Ref. No.	Note	Part No.	Description	Reqd. QTY	Serial No.	Parts catalogue code		
E-12	2	L	22000-ZM5-003	CLUTCH ASSY.	1		SAT, SAU, SAUT, SA2, SCT, SC2, SD, SDT, SE, SET, SJ, SJT, SUT		
					1	1100103	SAT/A, SAU/A, SAUT/A, SA2/A, SCT/A, SC2/A, SD/A, SDT/A, SE/A, SEGT SET/A, SJ/A, SJT/A, SUT/A		
		T		22000-ZOZ-003	1		SDS, SJS	
						1	1100104	SAT/A, SAU/A, SAUT/A, SA2/A, SCT/A, SC2/A, SD/A, SDT/A, SE/A, SEGT SET/A, SJ/A, SJT/A, SUT/A	
	3	L		22253-ZM5-003	BOLT, CLUTCH (8MM)	2		SAT, SAU, SAUT, SA2, SCT, SC2, SD, SDT, SE, SET, SJ, SJT, SUT	
						2	1100103	SAT/A, SAU/A, SAUT/A, SA2/A, SCT/A, SC2/A, SD/A, SDT/A, SE/A, SEGT SET/A, SJ/A, SJT/A, SUT/A	
			T		22253-ZOZ-003	2		SDS, SJS
							2	1100104	SAT/A, SAU/A, SAUT/A, SA2/A, SCT/A, SC2/A, SD/A, SDT/A, SE/A, SEGT SET/A, SJ/A, SJT/A, SUT/A
	6	T		22254-ZOZ-003	WASHER, WAVE (8MM)	2		SDS, SJS	
						2	1100104	SAT/A, SAU/A, SAUT/A, SA2/A, SCT/A, SC2/A, SD/A, SDT/A, SE/A, SEGT SET/A, SJ/A, SJT/A, SUT/A	

NOTE A:PART NO. CHANGE D:NEWLY PROVIDED E:PART NO.DELETION K:REQUIRED NO. CORRECTION L:APPLICATION SERIAL NO. CORRECTION
T:APPLICATION CORRECTION Z:REMARKS CHANGE

BOOKNo. : 13ZOZ401

Block No.	Ref. No.	Note	Part No.	Description	Reqd. QTY	Serial No.	Parts catalogue code
-----------	----------	------	----------	-------------	-----------	------------	----------------------

GX35

E-16 MUFFLER

Service	Item	F. R. T.
	FILTER, EXHAUST.....	0.1

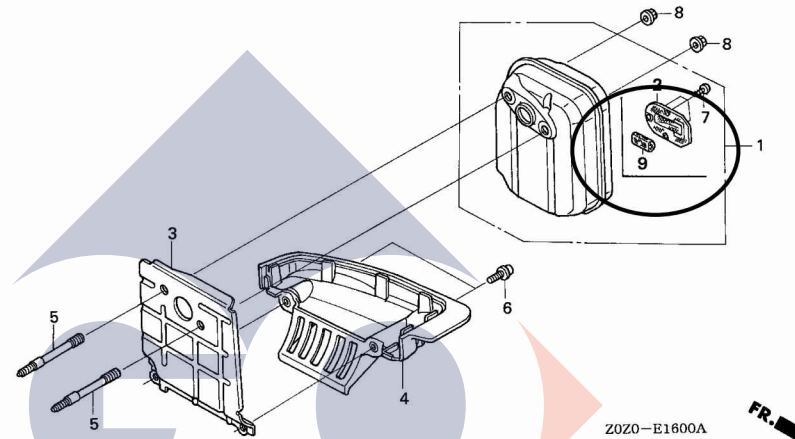

E-16	1	18310-ZOZ-800	MUFFLER COMP. (ARRESTER)	1	-----	SAT, SAU, SAUT, SA2, SCT, SC2, SUT
				1	----- 1119663	SAT/A, SAU/A, SAUT/A, SA2/A, SCT/A, SC2/A, SUT/A
	A	18310-ZOZ-801	1	1119664	SAT/A, SAU/A, SAUT/A, SA2/A, SCT/A, SC2/A, SUT/A
	9 D	18354-ZOZ-800	FILTER, EXHAUST	1	1119664	SAT/A, SAU/A, SAUT/A, SA2/A, SCT/A, SC2/A, SUT/A

NOTE A:PART NO. CHANGE D:NEWLY PROVIDED E:PART NO.DELETION K:REQUIRED NO. CORRECTION L:APPLICATION SERIAL NO. CORRECTION
T:APPLICATION CORRECTION Z:REMARKS CHANGE



PARTS CATALOGUE NEWS

Honda Motor Co., Ltd. Service Division

PARTS CATALOGUE - CORRECTED

Printed in Japan

CODE NO.	BOOKLET TYPE	13Z0Z401
	MICRO-FICHE	13Z0Z4EA/FA
PARTS CATALOGUE NEWS	GX35	
NEWS NO.	008	

Block No.	Ref. No.	Note	Part No.	Description	Reqd. QTY	Serial No.	Parts catalogue code		
					GX 35				
E-14	11	T	16022-ZM3-004	PIN, METERING LEVER	1	-----	SAT, SAU, SAUT, SA2, SCT, SC2, SD, SDT, SE, SET, SJ, SJT, SUT		
			16022-ZM3-014	1	-----	SAT/A, SAU/A, SAUT/A, SA2/A, SCT/A, SC2/A, SD/A, SDS, SDT/A, SE/A, SEGT, SET/A, SJ/A, SJS, SJT/A, SUT/A		
23	L		16100-Z0Z-004	CARBURETOR ASSY. (WYB 16A) ...	1	-----	SAT, SA2, SCT, SC2, SE, SET		
					1	1108635	SAT/A, SA2/A, SCT/A, SC2/A, SE/A, SET/A		
			16100-Z0Z-802	CARBURETOR ASSY. (WYB 15A) ...	1	-----	SAU, SAUT, SUT		
					1	1123125	SAU/A, SAUT/A, SUT/A		
			16100-Z0Z-812	CARBURETOR ASSY. (WYB 14A) ...	1	-----	SD, SDT, SJ, SJT		
					1	1108555	SD/A, SDT/A, SJ/A, SJT/A		
			16100-Z0Z-014	CARBURETOR ASSY. (WYB 16A) ...	1	-----	SEGT		
					1	1108636	SAT/A, SA2/A, SCT/A, SC2/A, SE/A, SET/A		
			A	16100-Z0Z-803	CARBURETOR ASSY. (WYB 15A) ...	1	1123126	-----	SAU/A, SAUT/A, SUT/A
			T	16100-Z0Z-813	CARBURETOR ASSY. (WYB 14A) ...	1	-----	-----	SDS, SJS
1	1108556	-----				SD/A, SDT/A, SJ/A, SJT/A			

NOTE A:PART NO. CHANGE D:NEWLY PROVIDED E:PART NO.DELETION K:REQUIRED NO. CORRECTION L:APPLICATION SERIAL NO. CORRECTION
T:APPLICATION CORRECTION Z:REMARKS CHANGE



PARTS CATALOGUE NEWS

Honda Motor Co., Ltd. Service Division

PARTS CATALOGUE - CORRECTED

Printed in Japan

CODE NO.	BOOKLET TYPE	13Z0Z401
	MICRO-FICHE	13Z0Z4EA/FA
PARTS CATALOGUE NEWS	GX35	
NEWS NO.	009	

Block No.	Ref. No.	Note	Part No.	Description	Reqd. QTY	Serial No.	Parts catalogue code
					GX 35		

E-2 CRANKCASE SET

Service Item	F.R.T.
ARM, EX. VALVE ROCKER.....	0.6
ARM, IN. VALVE ROCKER	
LIFTER COMP., IN. VALVE	
LIFTER, COMP., EX. VALVE	

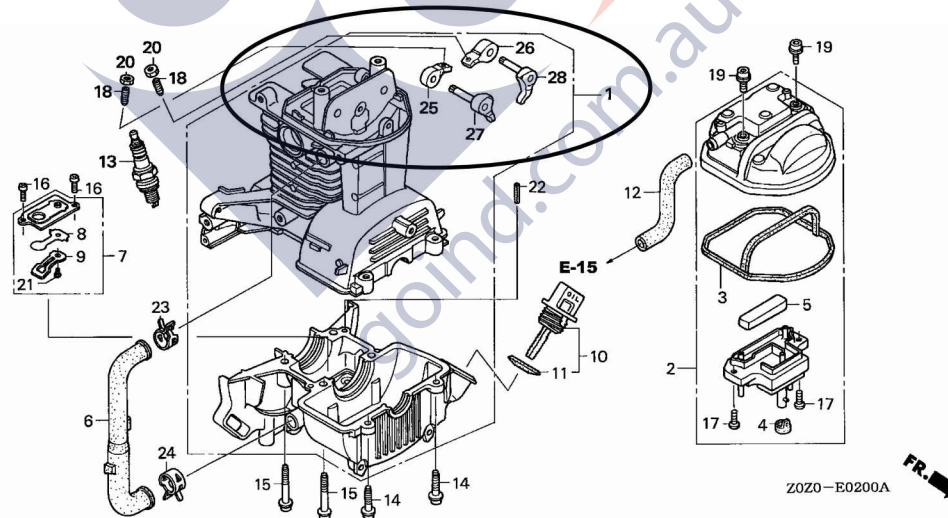

Z0Z0-E0200A

E-2	25	D	14431-Z0H-003	ARM, IN. VALVE ROCKER	1
-----	----	---	---------------	-----------------------------	---

NOTE A:PART NO. CHANGE D:NEWLY PROVIDED E:PART NO.DELETION K:REQUIRED NO. CORRECTION L:APPLICATION SERIAL NO. CORRECTION
T:APPLICATION CORRECTION Z:REMARKS CHANGE

PARTS CATALOGUE NEWS

BOOKNo. : 13ZOZ401

Block No.	Ref. No.	Note	Part No.	Description	Reqd. QTY	Serial No.	Parts catalogue code
	26	D	14441-Z0H-003	ARM, EX. VALVE ROCKER	1		
	27	D	14730-Z0Z-000	LIFTER COMP., IN. VALVE	1		
	28	D	14740-Z0Z-000	LIFTER, COMP., EX. VALVE	1		



NOTE A:PART NO. CHANGE D:NEWLY PROVIDED E:PART NO.DELETION K:REQUIRED NO. CORRECTION L:APPLICATION SERIAL NO. CORRECTION
T:APPLICATION CORRECTION Z:REMARKS CHANGE



PARTS CATALOGUE NEWS

Honda Motor Co., Ltd. Service Division

PARTS CATALOGUE - CORRECTED

Printed in Japan

CODE NO.	BOOKLET TYPE	13Z0Z401
	MICRO-FICHE	13Z0Z4EA/FA
PARTS CATALOGUE NEWS	GX35	
NEWS NO.	010	

Block No.	Ref. No.	Note	Part No.	Description	Reqd. QTY	Serial No.	Parts catalogue code	
					GX 35			
E-17	2		17511-Z0Z-003	TANK, FUEL	1	-----	SAT, SAU, SAUT, SA2, SCT, SC2, SD, SDT, SE, SET, SJ, SJT, SUT	
					1	----- 1128080	SAT/A, SAU/A, SAUT/A, SA2/A, SCT/A, SC2/A, SD/A, SDS, SDT/A, SE/A SEGT, SET/A, SJ/A, SJS, SJT/A, SUT/A	
	A	17511-Z0Z-013	1	1128081	-----	SAT/A, SAU/A, SAUT/A, SA2/A, SCT/A, SC2/A, SD/A, SDS, SDT/A, SE/A SEGT, SET/A, SJ/A, SJS, SJT/A, SUT/A	
	7		17672-ZM3-003	FILTER, FUEL	1	-----	SAT, SAU, SAUT, SA2, SCT, SC2, SD, SDT, SE, SET, SJ, SJT, SUT	
1					----- 1128080	SAT/A, SAU/A, SAUT/A, SA2/A, SCT/A, SC2/A, SD/A, SDS, SDT/A, SE/A SEGT, SET/A, SJ/A, SJS, SJT/A, SUT/A		
	A		17672-Z0H-003	1	1128081	-----	SAT/A, SAU/A, SAUT/A, SA2/A, SCT/A, SC2/A, SD/A, SDS, SDT/A, SE/A SEGT, SET/A, SJ/A, SJS, SJT/A, SUT/A

NOTE A:PART NO. CHANGE D:NEWLY PROVIDED E:PART NO.DELETION K:REQUIRED NO. CORRECTION L:APPLICATION SERIAL NO. CORRECTION
T:APPLICATION CORRECTION Z:REMARKS CHANGE



PARTS CATALOGUE NEWS

Honda Motor Co., Ltd. Service Division

PARTS CATALOGUE - CORRECTED

Printed in Japan

CODE NO.	BOOKLET TYPE	13Z0Z401
	MICRO- FICHE	13Z0Z4EA/FA
PARTS CATALOGUE NEWS	GX35	
NEWS NO.	011	

Block No.	Ref. No.	Note	Part No.	Description	Reqd. QTY	Serial No.		Parts catalogue code
					GX 35			
E-14	23		16100-Z0Z-014	CARBURETOR ASSY. (WYB 16A) ...	1	-----	1136058	SEGT
					1		1108636 1136058	SAT/A, SA2/A, SCT/A, SC2/A, SE/A, SET/A
		A	16100-Z0Z-024	CARBURETOR ASSY. (WYB 16B) ...	1		1136059	SAT/A, SA2/A, SCT/A, SC2/A, SE/A, SEGT, SET/A

NOTE A:PART NO. CHANGE D:NEWLY PROVIDED E:PART NO.DELETION K:REQUIRED NO. CORRECTION L:APPLICATION SERIAL NO. CORRECTION
T:APPLICATION CORRECTION Z:REMARKS CHANGE



PARTS CATALOGUE NEWS

Honda Motor Co., Ltd. Service Division

PARTS CATALOGUE - CORRECTED

Printed in Japan

CODE NO.	BOOKLET TYPE	13Z0Z401
	MICRO-FICHE	13Z0Z4EA/FA
PARTS CATALOGUE NEWS	GX35	
NEWS NO.	012	

Block No.	Ref. No.	Note	Part No.	Description	Reqd. QTY	Serial No.	Parts catalogue code
					GX 35		
E-14	25	L	19631-Z0Z-000	SHROUD	1	-----	SAT, SAU, SAUT, SA2, SCT, SC2, SD, SDT, SE, SET, SJ, SJT, SUT
					1	----- 1139911	SAT/A, SAU/A, SAUT/A, SA2/A, SCT/A, SC2/A, SD/A, SDS, SDT/A, SE/A SEGT, SET/A, SJ/A, SJS, SJT/A, SUT/A
		A	19631-Z0Z-010	1	----- 1139912	SAT/A, SAU/A, SAUT/A, SA2/A, SCT/A, SC2/A, SD/A, SDS, SDT/A, SE/A SEGT, SET/A, SJ/A, SJS, SJT/A, SUT/A

NOTE A:PART NO. CHANGE D:NEWLY PROVIDED E:PART NO.DELETION K:REQUIRED NO. CORRECTION L:APPLICATION SERIAL NO. CORRECTION
T:APPLICATION CORRECTION Z:REMARKS CHANGE



PARTS CATALOGUE NEWS

Honda Motor Co., Ltd. Service Division

December 11, 2004

CODE NO.	BOOKLET TYPE	13Z0Z401
	MICRO-FICHE	13Z0Z4EA/FA
PARTS CATALOGUE NEWS	GX35	
NEWS NO.	013	

Printed in Japan

GX35-SLT TYPE sales parts information

NOTE: This Parts Catalogue News explains only the parts of the different model that are produced to conform to addition of the GX35-SLT type.

As for the parts not listed on this Parts Catalogue News, use the parts of the GX35-SAT/A type.

Model	Type		Parts catalogue type	Applicable engine serial No.	Applicable carburetor identification No.
GX35	SAT	Base model	SAT/A	GCACM-1100001~	WYB 16A,WYB 16B
	SLT	Additional model	SLT		WYB 16B

NOTE A:PART NO. CHANGE D:NEWLY PROVIDED E:PART NO.DELETION K:REQUIRED NO. CORRECTION L:APPLICATION SERIAL NO. CORRECTION
T:APPLICATION CORRECTION Z:REMARKS CHANGE

PARTS CATALOGUE NEWS

BOOKNo. :13ZOZ401

Block No.	Ref. No.	Part No.	Description	Reqd. QTY	Base Part No.	Parts catalogue code
				GX 35		
E-17	5		CAP ASSY., FUEL TANK	0	17620-ZM3-053	
	6	17620-ZM3-816	CAP ASSY., FUEL TANK	1		
E-19	1	30500-ZOZ-013	COIL ASSY., IGNITION	1	30500-ZOZ-003	
E-28	4	87601-ZOZ-V30	MARK, TYPE (SLT)	1	87601-ZOH-860	



NOTE A:PART NO. CHANGE D:NEWLY PROVIDED E:PART NO.DELETION K:REQUIRED NO. CORRECTION L:APPLICATION SERIAL NO. CORRECTION
T:APPLICATION CORRECTION Z:REMARKS CHANGE



PARTS CATALOGUE NEWS

Honda Motor Co., Ltd. Service Division

PARTS CATALOGUE - CORRECTED

Printed in Japan

CODE NO.	BOOKLET TYPE	13Z0Z401
	MICRO-FICHE	13Z0Z4EA/FA
PARTS CATALOGUE TITLE	GX35	
NEWS NO.	014	

Block No.	Ref. No.	Note	Part No.	Description	Reqd. QTY	Serial No.	Parts catalogue code
					GX 35		
E-14	2		16011-Z0H-003	GASKET, PUMP	1	-----	SAT, SAU, SAUT, SA2, SCT, SC2, SD, SDT, SE, SET, SJ, SJT, SUT
				(CARBURETOR NO.)	1	----- WYB 14A	SD/A, SDS, SDT/A, SJ/A, SJS, SJT/A
				(CARBURETOR NO.)	1	----- WYB 15A	SAU/A, SAUT/A, SUT/A
				(CARBURETOR NO.)	1	----- WYB 16B	SAT/A, SA2/A, SCT/A, SC2/A, SE/A, SEGT, SET/A, SLT
	A		16011-Z0H-013	(CARBURETOR NO.)	1	WYB 14B -----	SD/A, SDS, SDT/A, SJ/A, SJS, SJT/A
				(CARBURETOR NO.)	1	WYB 15B -----	SAU/A, SAUT/A, SUT/A
				(CARBURETOR NO.)	1	WYB 16C -----	SAT/A, SA2/A, SCT/A, SC2/A, SE/A, SEGT, SET/A, SLT
	5		16015-Z0H-003	BODY ASSY., PUMP	1	-----	SAT, SAU, SAUT, SA2, SCT, SC2, SD, SDT, SE, SET, SJ, SJT, SUT
				(CARBURETOR NO.)	1	----- WYB 14A	SD/A, SDS, SDT/A, SJ/A, SJS, SJT/A
				(CARBURETOR NO.)	1	----- WYB 15A	SAU/A, SAUT/A, SUT/A
(CARBURETOR NO.)				1	----- WYB 16B	SAT/A, SA2/A, SCT/A, SC2/A, SE/A, SEGT, SET/A, SLT	
A		16015-Z0H-013	(CARBURETOR NO.)	1	WYB 14B -----	SD/A, SDS, SDT/A, SJ/A, SJS, SJT/A	

NOTE A:PART NO. CHANGE D:NEWLY PROVIDED E:PART NO.DELETION K:REQUIRED NO. CORRECTION L:APPLICATION SERIAL NO. CORRECTION
T:APPLICATION CORRECTION Z:REMARKS CHANGE

PARTS CATALOGUE NEWS

BOOKNo. : 13ZOZ401

Block No.	Ref. No.	Note	Part No.	Description	Reqd. QTY	Serial No.	Parts catalogue code
				(CARBURETOR NO.)	1	WYB 15B -----	SAU/A, SAUT/A, SUT/A
				(CARBURETOR NO.)	1	WYB 16C -----	SAT/A, SA2/A, SCT/A, SC2/A, SE/A, SEGT, SET/A, SLT



NOTE A:PART NO. CHANGE D:NEWLY PROVIDED E:PART NO.DELETION K:REQUIRED NO. CORRECTION L:APPLICATION SERIAL NO. CORRECTION
T:APPLICATION CORRECTION Z:REMARKS CHANGE



PARTS CATALOGUE NEWS

Honda Motor Co., Ltd. Service Division

PARTS CATALOGUE - CORRECTED

Printed in Japan

CODE NO.	BOOKLET TYPE	13Z0Z401
	MICRO-FICHE	13Z0Z4EA/FA
PARTS CATALOGUE TITLE	GX35	
NEWS NO.	015	

Block No.	Ref. No.	Note	Part No.	Description	Reqd. QTY	Serial No.	Parts catalogue code
E-28		LABEL			GX 35		

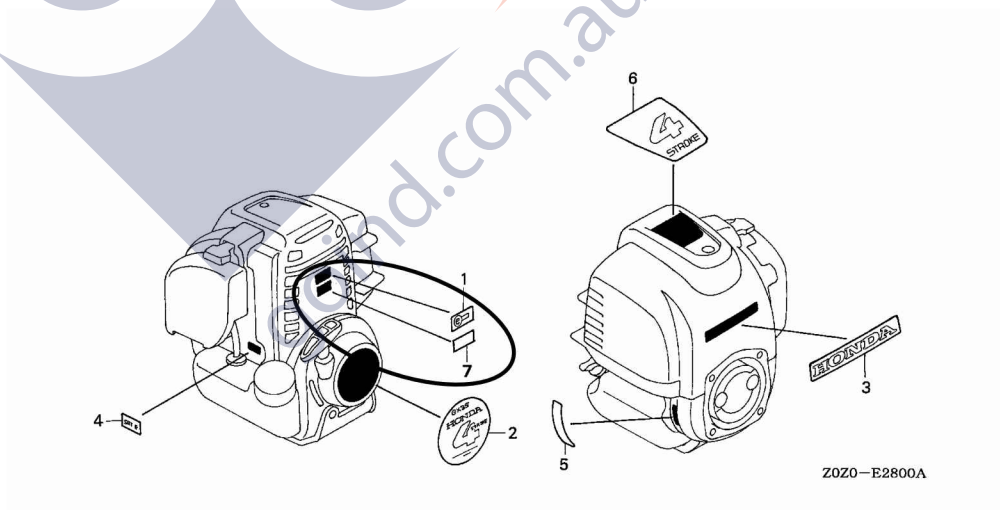

NOTE A:PART NO. CHANGE D:NEWLY PROVIDED E:PART NO.DELETION K:REQUIRED NO. CORRECTION L:APPLICATION SERIAL NO. CORRECTION
T:APPLICATION CORRECTION Z:REMARKS CHANGE

PARTS CATALOGUE NEWS

BOOKNo. : 13ZOZ401

Block No.	Ref. No.	Note	Part No.	Description	Reqd. QTY GX 35	Serial No.	Parts catalogue code
E-28	7	D	87114-ZH7-000	LABEL, WARNING (NOT CERTIFIED FOR SALE)	1	1159127 -----	SD/A, SDS, SDT/A, SJ/A, SJS, SJT/A



NOTE A:PART NO. CHANGE D:NEWLY PROVIDED E:PART NO.DELETION K:REQUIRED NO. CORRECTION L:APPLICATION SERIAL NO. CORRECTION
T:APPLICATION CORRECTION Z:REMARKS CHANGE



PARTS CATALOGUE NEWS

Honda Motor Co., Ltd. Service Division

PARTS CATALOGUE - CORRECTED

Printed in Japan

CODE NO.	BOOKLET TYPE	13Z0Z401
	MICRO-FICHE	13Z0Z4EA/FA
PARTS CATALOGUE TITLE	GX35	
NEWS NO.	016	

Block No.	Ref. No.	Note	Part No.	Description	Reqd. QTY		Serial No.	Parts catalogue code	
						GX35			
E-14	23		16100-Z0Z-803	CARBURETOR ASSY. (WYB 15A) ...	1		1123126 1170924	SAU/A, SAUT/A, SUT/A	
			16100-Z0Z-813	CARBURETOR ASSY. (WYB 14A) ...	1	-----	1167584	SDS, SJS	
					1	1108556 1167584	SD/A, SDT/A, SJ/A, SJT/A		
			16100-Z0Z-024	CARBURETOR ASSY. (WYB 16B) ...	1	-----	1168438	SLT	
					1	1136059 1168438	SAT/A, SA2/A, SCT/A, SC2/A, SE/A, SEGT, SET/A		
			A	16100-Z0Z-804	CARBURETOR ASSY. (WYB 15B) ...	1	1170925	-----	SAU/A, SAUT/A, SUT/A
			A	16100-Z0Z-814	CARBURETOR ASSY. (WYB 14B) ...	1	1167585	-----	SD/A, SDS, SDT/A, SJ/A, SJS, SJT/A
A	16100-Z0Z-034	CARBURETOR ASSY. (WYB 16C) ...	1	1168439	-----	SAT/A, SA2/A, SCT/A, SC2/A, SE/A, SEGT, SET/A, SLT			
E-16	4		18518-Z0Z-000	GUIDE COMP., UNDER AIR	1	-----	-----	SAT, SAU, SAUT, SA2, SCT, SC2, SD, SDT, SE, SET, SJ, SJT, SUT	
					1	-----	1186547	SAT/A, SAU/A, SAUT/A, SA2/A, SCT/A, SC2/A, SD/A, SDS, SDT/A, SE/A, SEGT, SET/A, SJ/A, SJS, SJT/A, SLT, SUT/A	
			A	18518-Z0Z-010	1	1186548	-----	SAT/A, SAU/A, SAUT/A, SA2/A, SCT/A, SC2/A, SD/A, SDS, SDT/A, SE/A, SEGT, SET/A, SJ/A, SJS, SJT/A, SLT, SUT/A
E-19	1	L	30500-Z0Z-003	COIL ASSY., IGNITION	1	-----	-----	SAT, SAU, SAUT, SA2, SCT, SC2, SD, SDT, SE, SET, SJ, SJT, SUT	

NOTE A:PART NO. CHANGE D:NEWLY PROVIDED E:PART NO.DELETION K:REQUIRED NO. CORRECTION L:APPLICATION SERIAL NO. CORRECTION
T:APPLICATION CORRECTION Z:REMARKS CHANGE

PARTS CATALOGUE NEWS

BOOKNo. : 13ZOZ401

Block No.	Ref. No.	Note	Part No.	Description	Reqd. QTY GX 35	Serial No.	Parts catalogue code
					1	----- 1147205	SAT/A, SAU/A, SAUT/A, SA2/A, SCT/A, SC2/A, SD/A, SDS, SDT/A, SE/A SEGT, SET/A, SJ/A, SJS, SJT/A, SUT/A
		T	30500-ZOZ-013	1	-----	SLT
					1	1147206 -----	SAT/A, SAU/A, SAUT/A, SA2/A, SCT/A, SC2/A, SD/A, SDS, SDT/A, SE/A SEGT, SET/A, SJ/A, SJS, SJT/A, SUT/A
E-28	7	D	87114-ZH7-810	LABEL, WARNING (NOT CERTIFIED FOR SALE)	1	1226976 -----	SAU/A, SAUT/A, SUT/A



NOTE A:PART NO. CHANGE D:NEWLY PROVIDED E:PART NO.DELETION K:REQUIRED NO. CORRECTION L:APPLICATION SERIAL NO. CORRECTION
T:APPLICATION CORRECTION Z:REMARKS CHANGE



PARTS CATALOGUE NEWS

Honda Motor Co., Ltd. Service Division

PARTS CATALOGUE - CORRECTED

Printed in Japan

CODE NO.	BOOKLET TYPE	13Z0Z401
	MICRO-FICHE	13Z0Z4EA/FA
PARTS CATALOGUE TITLE	GX35	
NEWS NO.	017	

Block No.	Ref. No.	Note	Part No.	Description	Reqd. QTY	Serial No.	Parts catalogue code
					GX 35		
E-2	1		10100-Z0Z-405	CRANKCASE SET	1	-----	SAT, SAU, SAUT, SA2, SCT, SC2, SD, SDT, SE, SET, SJ, SJT, SUT
					1	1183074	SAT/A, SAU/A, SAUT/A, SA2/A, SCT/A, SC2/A, SD/A, SDS, SDT/A, SE/A SEGT, SET/A, SJ/A, SJS, SJT/A, SLT, SUT/A
					1	1183075	SAT/A, SAU/A, SAUT/A, SA2/A, SCT/A, SC2/A, SD/A, SDS, SDT/A, SE/A SEGT, SET/A, SJ/A, SJS, SJT/A, SLT, SUT/A
E-10	1		12209-Z0H-003	SEAL, VALVE STEM	1	-----	SAT, SAU, SAUT, SA2, SCT, SC2, SD, SDT, SE, SET, SJ, SJT, SUT
					1	1183074	SAT/A, SAU/A, SAUT/A, SA2/A, SCT/A, SC2/A, SD/A, SDS, SDT/A, SE/A SEGT, SET/A, SJ/A, SJS, SJT/A, SLT, SUT/A
	A		12209-Z3E-000	1	1183075	SAT/A, SAU/A, SAUT/A, SA2/A, SCT/A, SC2/A, SD/A, SDS, SDT/A, SE/A SEGT, SET/A, SJ/A, SJS, SJT/A, SLT, SUT/A
					1	-----	SAT, SAU, SAUT, SA2, SCT, SC2, SD, SDT, SE, SET, SJ, SJT, SUT
	5		14711-Z0Z-000	VALVE, IN.	1	-----	SAT, SAU, SAUT, SA2, SCT, SC2, SD, SDT, SE, SET, SJ, SJT, SUT
					1	1183074	SAT/A, SAU/A, SAUT/A, SA2/A, SCT/A, SC2/A, SD/A, SDS, SDT/A, SE/A SEGT, SET/A, SJ/A, SJS, SJT/A, SLT, SUT/A
A		14711-Z0Z-800	1	1183075	SAT/A, SAU/A, SAUT/A, SA2/A, SCT/A, SC2/A, SD/A, SDS, SDT/A, SE/A SEGT, SET/A, SJ/A, SJS, SJT/A, SLT, SUT/A	
				1	-----	SAT, SAU, SAUT, SA2, SCT, SC2, SD, SDT, SE, SET, SJ, SJT, SUT	
6			14721-Z0Z-000	VALVE, EX.	1	-----	SAT, SAU, SAUT, SA2, SCT, SC2, SD, SDT, SE, SET, SJ, SJT, SUT

NOTE A:PART NO. CHANGE D:NEWLY PROVIDED E:PART NO.DELETION K:REQUIRED NO. CORRECTION L:APPLICATION SERIAL NO. CORRECTION
T:APPLICATION CORRECTION Z:REMARKS CHANGE

PARTS CATALOGUE NEWS

BOOKNo. : 13ZOZ401

Block No.	Ref. No.	Note	Part No.	Description	Reqd. QTY GX 35	Serial No.	Parts catalogue code
					1	----- 1183074	SAT/A, SAU/A, SAUT/A, SA2/A, SCT/A, SC2/A, SD/A, SDS, SDT/A, SE/A SEGT, SET/A, SJ/A, SJS, SJT/A, SLT, SUT/A
		A	14721-ZOZ-800	1	1183075 -----	SAT/A, SAU/A, SAUT/A, SA2/A, SCT/A, SC2/A, SD/A, SDS, SDT/A, SE/A SEGT, SET/A, SJ/A, SJS, SJT/A, SLT, SUT/A
E-28	7	L	87114-ZH7-000	LABEL, WARNING (NOT CERTIFIED FOR SALE)	1	1159127 1186547	SD/A, SDS, SDT/A, SJ/A, SJS, SJT/A
		T	87114-ZH7-810	1	1186548 -----	SD/A, SDS, SDT/A, SJ/A, SJS, SJT/A
					1	1226976 -----	SAU/A, SAUT/A, SUT/A

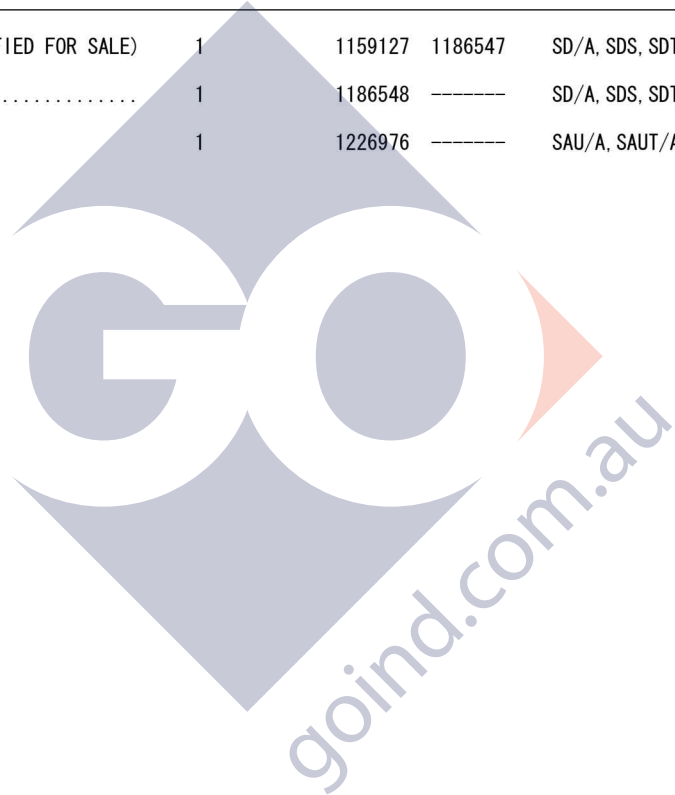

NOTE A:PART NO. CHANGE D:NEWLY PROVIDED E:PART NO.DELETION K:REQUIRED NO. CORRECTION L:APPLICATION SERIAL NO. CORRECTION
T:APPLICATION CORRECTION Z:REMARKS CHANGE



PARTS CATALOGUE NEWS

Honda Motor Co., Ltd. Service Division

PARTS CATALOGUE - CORRECTED

Printed in Japan

CODE NO.	BOOKLET TYPE	13Z0Z401
	MICRO-FICHE	13Z0Z4EA/FA
PARTS CATALOGUE TITLE	GX35	
NEWS NO.	018	

Block No.	Ref. No.	Note	Part No.	Description	Reqd. QTY	Serial No.	Parts catalogue code
E-2					GX 35		
CRANKCASE SET							

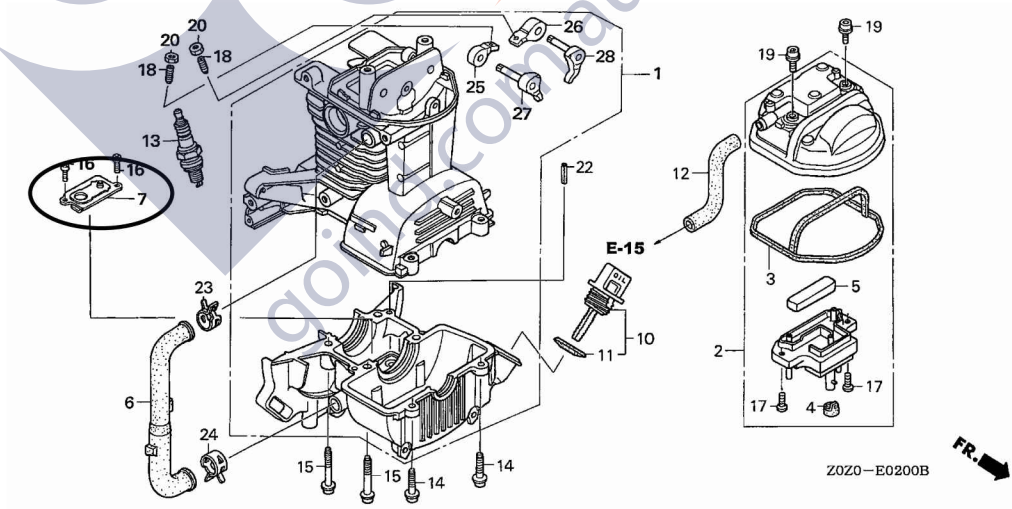

E-2 8 E 15571-ZM3-003 *PARTS NO. DELETION

NOTE A:PART NO. CHANGE D:NEWLY PROVIDED E:PART NO.DELETION K:REQUIRED NO. CORRECTION L:APPLICATION SERIAL NO. CORRECTION
T:APPLICATION CORRECTION Z:REMARKS CHANGE

PARTS CATALOGUE NEWS

BOOKNo. : 13ZOZ401

Block No.	Ref. No.	Note	Part No.	Description	Reqd. QTY	Serial No.	Parts catalogue code
	9	E	15572-Z0H-000	*PARTS NO. DELETION	GX 35		
	21	E	93500-03005-0A	*PARTS NO. DELETION			



NOTE A:PART NO. CHANGE D:NEWLY PROVIDED E:PART NO.DELETION K:REQUIRED NO. CORRECTION L:APPLICATION SERIAL NO. CORRECTION
T:APPLICATION CORRECTION Z:REMARKS CHANGE



PARTS CATALOGUE NEWS

Honda Motor Co., Ltd. Service Division

PARTS CATALOGUE - CORRECTED

Printed in Japan

CODE NO.	BOOKLET TYPE	13Z0Z401
	MICRO-FICHE	13Z0Z4EA/FA
PARTS CATALOGUE NEWS	GX35	
NEWS NO.	019	

Block No.	Ref. No.	Note	Part No.	Description	Reqd. QTY	Serial No.	Parts catalogue code
E-11	10	E	28442-ZM3-003	*PARTS NO. DELETION	GX 35		
		D	28442-Z0H-003	SPRING, RECOIL STARTER	1		

NOTE A:PART NO. CHANGE D:NEWLY PROVIDED E:PART NO.DELETION K:REQUIRED NO. CORRECTION L:APPLICATION SERIAL NO. CORRECTION
T:APPLICATION CORRECTION Z:REMARKS CHANGE



PARTS CATALOGUE NEWS

Honda Motor Co., Ltd. Service Division

PARTS CATALOGUE - CORRECTED

Printed in Japan

CODE NO.	BOOKLET TYPE	13Z0Z401
	MICRO-FICHE	13Z0Z4EA/FA
PARTS CATALOGUE NEWS	GX35	
NEWS NO.	020	

Block No.	Ref. No.	Note	Part No.	Description	Reqd. QTY	Serial No.	Parts catalogue code
E-28		LABEL			GX 35		

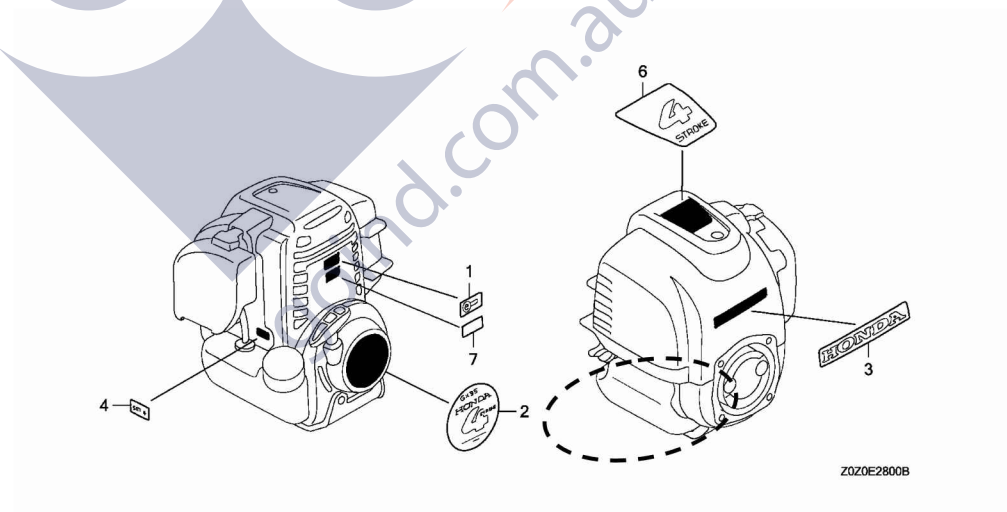

E-28 5 E 87637-ZM3-800 *PARTS NO. DELETION

NOTE A:PART NO. CHANGE D:NEWLY PROVIDED E:PART NO.DELETION K:REQUIRED NO. CORRECTION L:APPLICATION SERIAL NO. CORRECTION T:APPLICATION CORRECTION Z:REMARKS CHANGE



PARTS CATALOGUE NEWS

Honda Motor Co., Ltd. Service Division

PARTS CATALOGUE - CORRECTED

Printed in Japan

CODE NO.	BOOKLET TYPE	13Z0Z401
	MICRO-FICHE	13Z0Z4EA/FA
PARTS CATALOGUE NEWS	GX35	
NEWS NO.	021	

Block No.	Ref. No.	Note	Part No.	Description	Reqd. QTY	Serial No.	Parts catalogue code
E-14					GX 35		

ILLUSTRATION CORRECTED

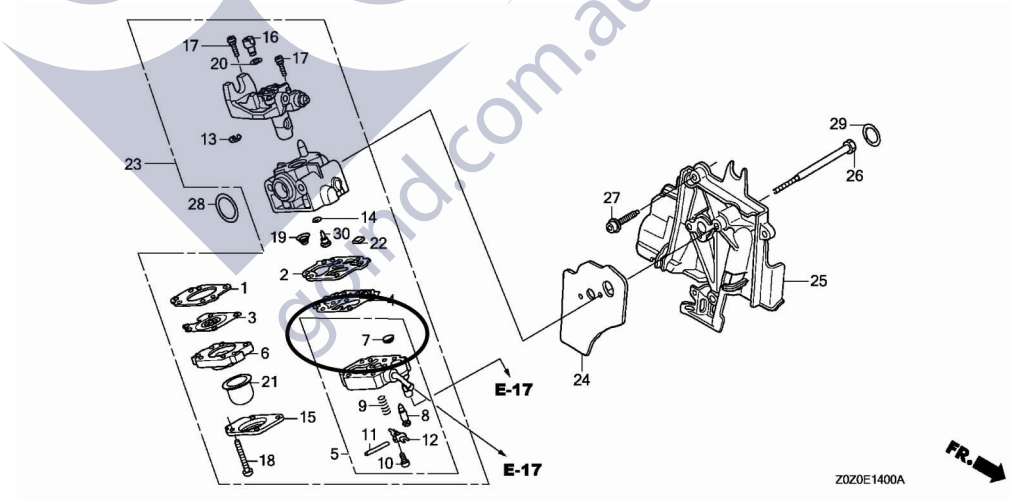

Z0Z0E1400A

NOTE A:PART NO. CHANGE D:NEWLY PROVIDED E:PART NO.DELETION K:REQUIRED NO. CORRECTION L:APPLICATION SERIAL NO. CORRECTION
T:APPLICATION CORRECTION Z:REMARKS CHANGE



PARTS CATALOGUE NEWS

Honda Motor Co., Ltd. Service Division

PARTS CATALOGUE - CORRECTED

Printed in Japan

CODE NO.	BOOKLET TYPE	13Z0Z401
	MICRO-FICHE	13Z0Z4EA/FA
PARTS CATALOGUE NEWS	GX35	
NEWS NO.	022	

Block No.	Ref. No.	Note	Part No.	Description	Reqd. QTY	Serial No.	Parts catalogue code
E-15					GX 35		
				AIR CLEANER			

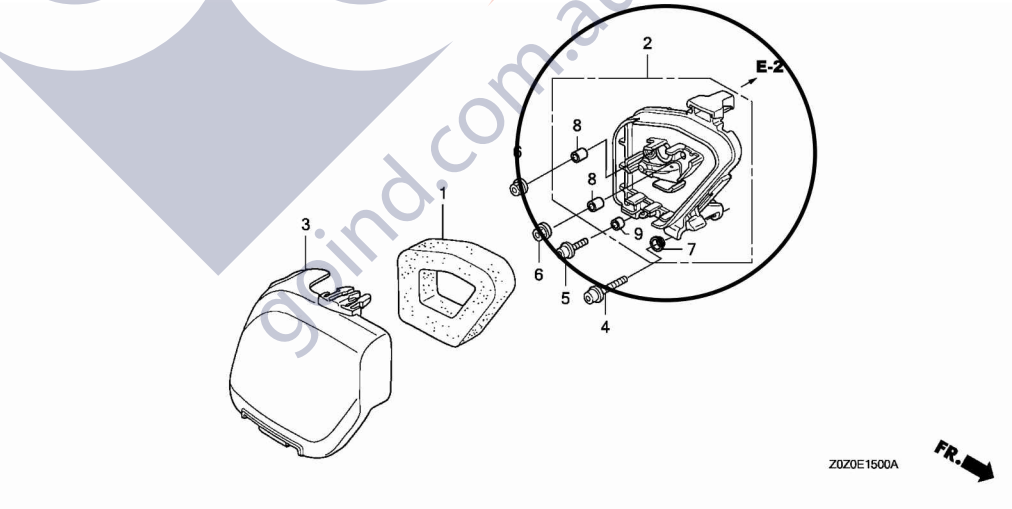

Z0Z0E1500A



E-15	7	D	91501-Z0Z-000	COLLAR, AIR CLEANER CASE	1		
------	---	---	---------------	------------------------------------	---	--	--

NOTE A:PART NO. CHANGE D:NEWLY PROVIDED E:PART NO.DELETION K:REQUIRED NO. CORRECTION L:APPLICATION SERIAL NO. CORRECTION
T:APPLICATION CORRECTION Z:REMARKS CHANGE

PARTS CATALOGUE NEWS

BOOKNo. : 13ZOZ401

Block No.	Ref. No.	Note	Part No.	Description	Reqd. QTY	Serial No.	Parts catalogue code
	8	D	91503-ZM3-000	COLLAR, AIR CLEANER	2		
	9	D	91506-ZM3-000	COLLAR A, HEAD COVER	1		



NOTE A:PART NO. CHANGE D:NEWLY PROVIDED E:PART NO.DELETION K:REQUIRED NO. CORRECTION L:APPLICATION SERIAL NO. CORRECTION
T:APPLICATION CORRECTION Z:REMARKS CHANGE