

DO NOT SCALE FROM DRAWING. IF IN DOUBT: ASK

UNLESS OTHERWISE SPECIFIED, ALL DIMENSIONS ARE IN MILLIMETRES

BEWARE OF 100mm MEASURING ERROR

**TANK DATA**

TANK CONTENTS:	DIESEL
DESIGNED TO:	AS1692
CORROSION ALLOW.	0mm
THICKNESS OF PLATE	3mm
GROSS VOLUME:	12,630L
HYD.TEST PRESSURE:	Gross level+150mm
SAFE FILL LEVEL	12,000L
N.D.T.	Refer fabrication & assembly plan
TOTAL MASS:	1017.74kg (EMPTY)

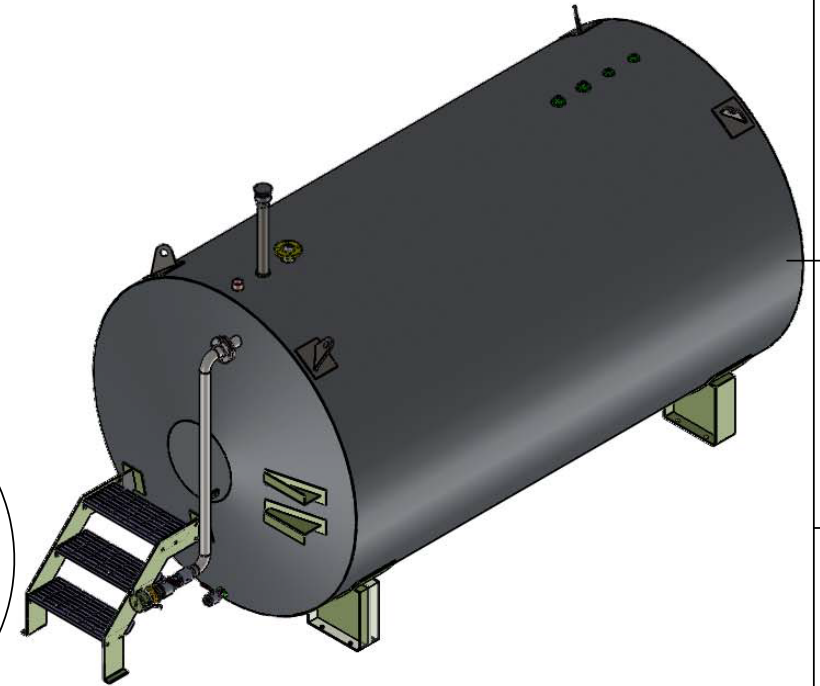
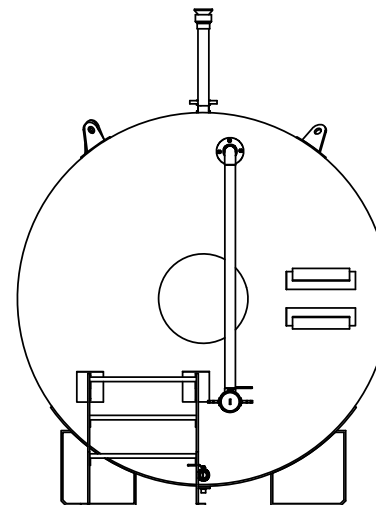
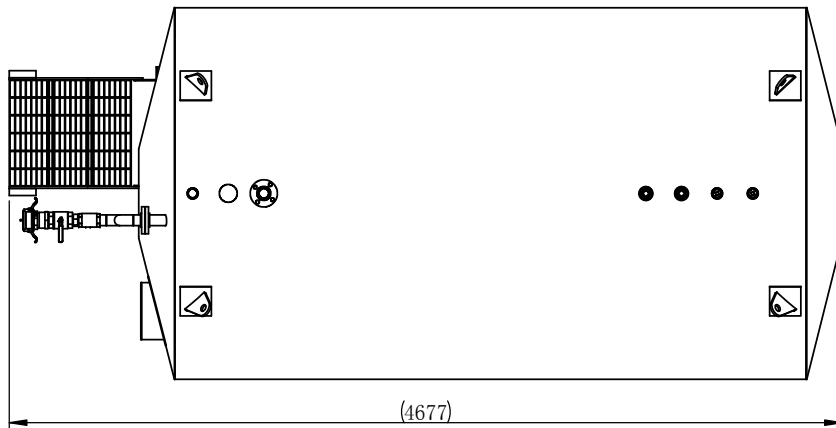
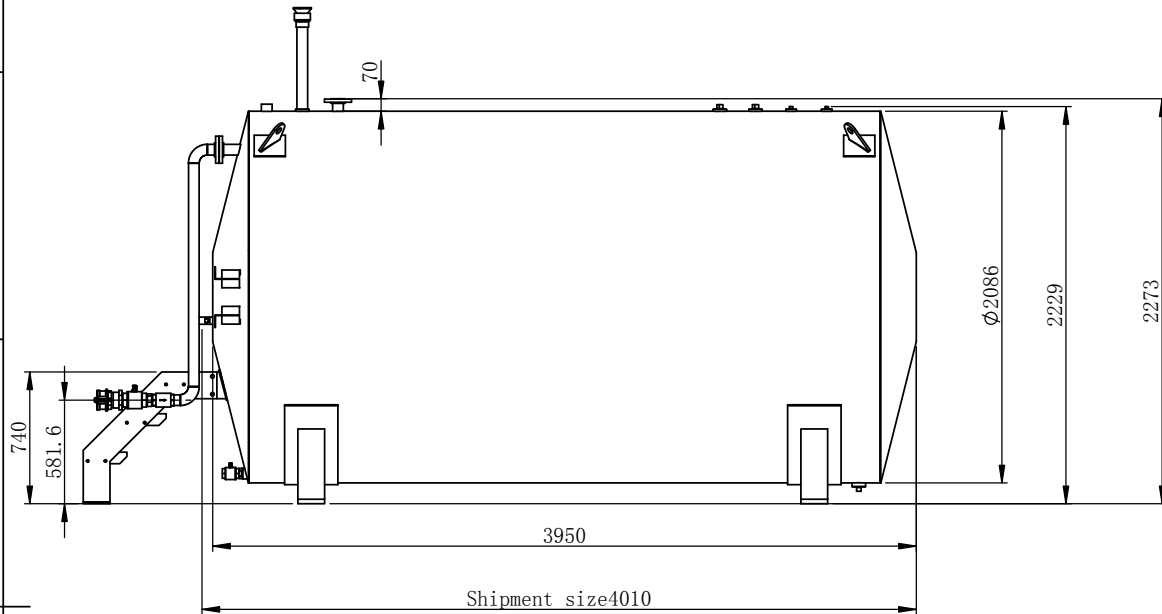

Material of construction: Carbon steel Q235B

THIRD ANGLE PROJECTION	
COPYRIGHT © 2016	
NAME	DATE
DRAWN	
CHK'D	
APP'VD	



TOLERANCE U.N.O.	MATERIAL
0 = -1.0	
0.0 = -0.4	
0.00 = -0.1	WEIGHT: 1017.74 Kg

DWG NO. / PART NO.	JOB NO.
<b>FAR-12</b>	
<b>FAR 12,000L Safe Fill Level Single Wall Tank</b>	
TITLE:	SHEET SIZE
	<b>A3</b>
SCALE: N.T.S.	REVISION
SHEET 1 OF 3	<b>01</b>

DO NOT SCALE FROM DRAWING. IF IN DOUBT: ASK

UNLESS OTHERWISE SPECIFIED, ALL DIMENSIONS ARE IN MILLIMETRES

BEWARE OF 100mm MEASURING ERROR

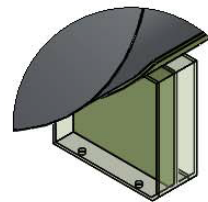
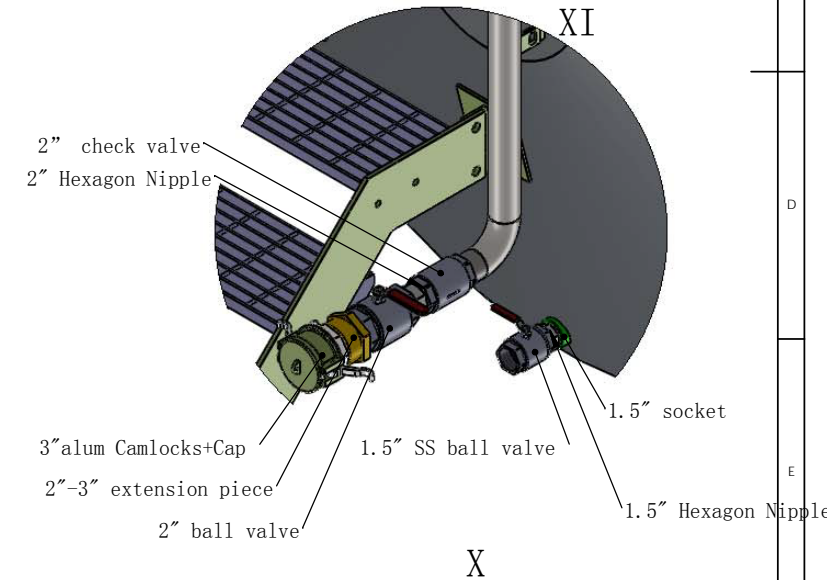
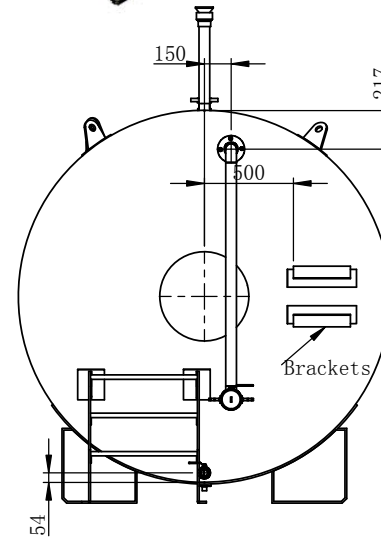
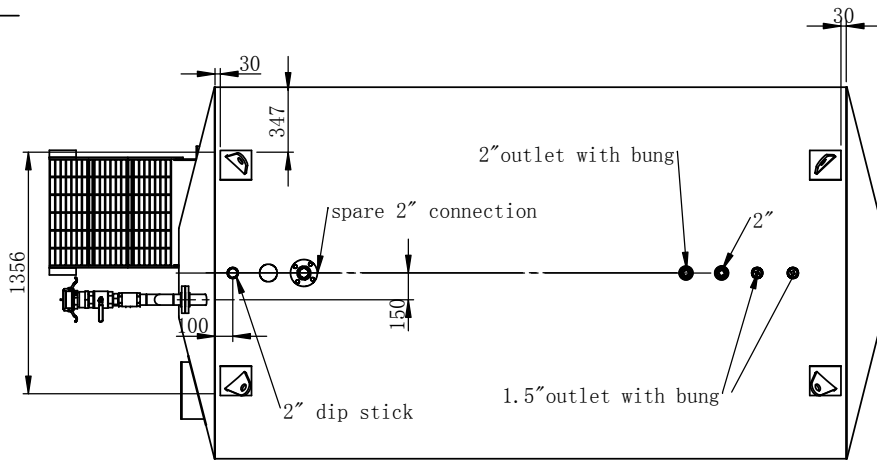
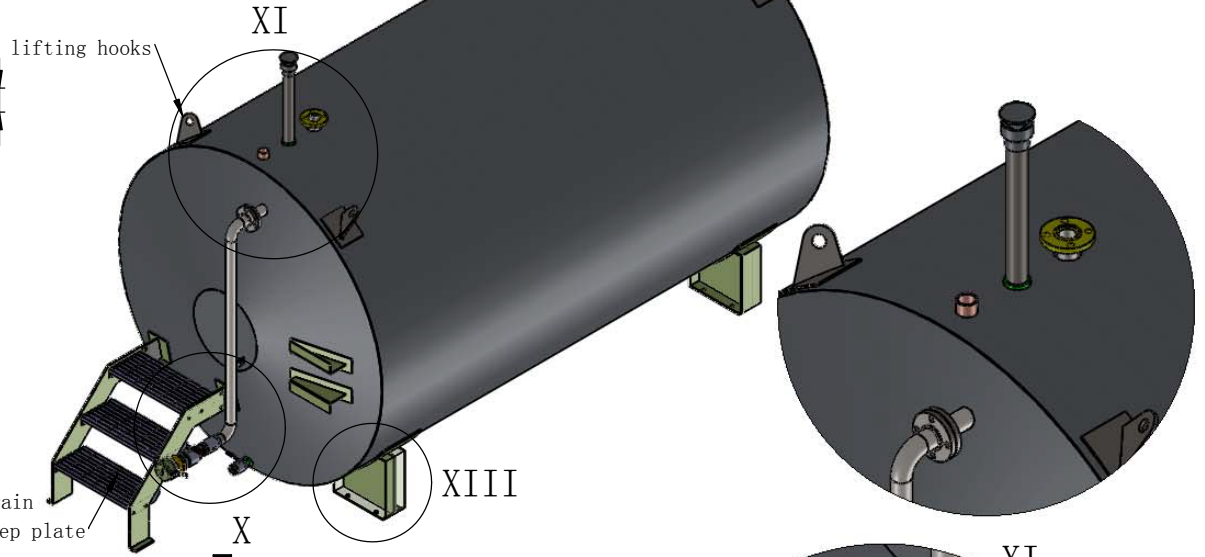
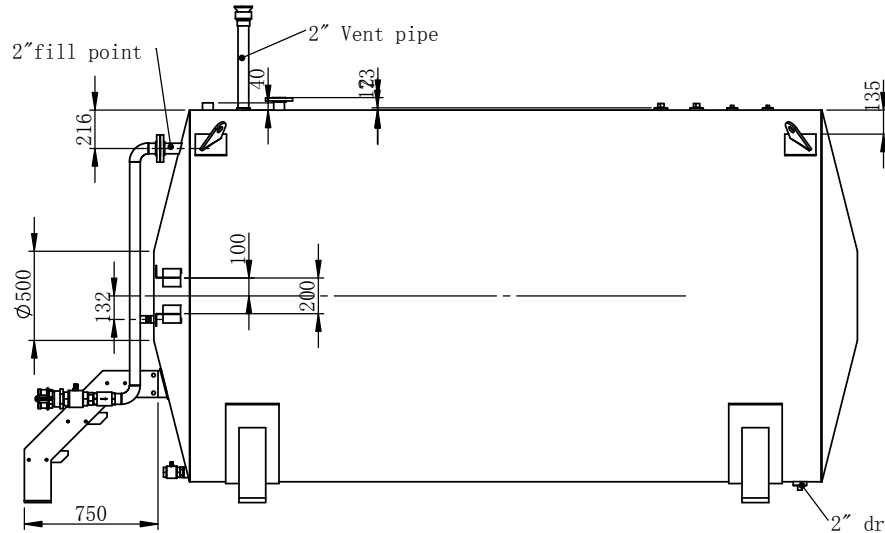

XIII

THIRD ANGLE PROJECTION	
COPYRIGHT © 2006	
NAME	DATE
DRAWN	
CHK'D	
APP'VD	



TOLERANCE U.N.O.  
0 = -1.0  
0.0 = -0.4  
0.00 = -0.1

MATERIAL  
WEIGHT: 1017.74 Kg

DWG NO. / PART NO. <b>FAR-12</b>		JOB NO.
<b>FAR 12,000L Safe Fill Level Single Wall Tank</b>		
TITLE:		SHEET SIZE <b>A3</b>
SCALE: N.T.S.		REVISION <b>01</b>
SHEET 2 OF 3		

DO NOT SCALE FROM DRAWING. IF IN DOUBT: ASK

UNLESS OTHERWISE SPECIFIED, ALL DIMENSIONS ARE IN MILLIMETRES

BEWARE OF 100mm MEASURING ERROR

Saddle thickness:10mm  
 wrapper pad thickness:10mm  
 Lifting lug thickness:12mm  
 comp. pad thickness:6mm

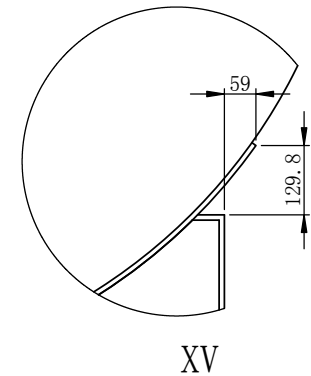
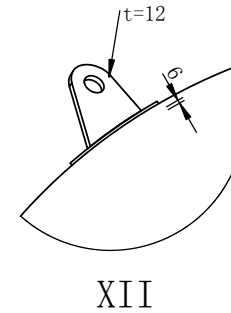
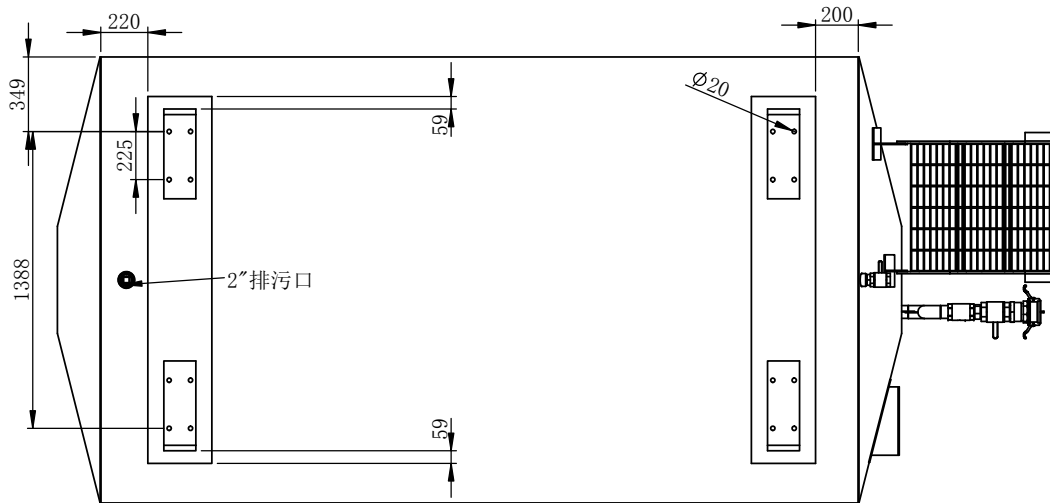
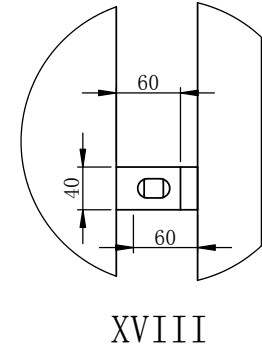
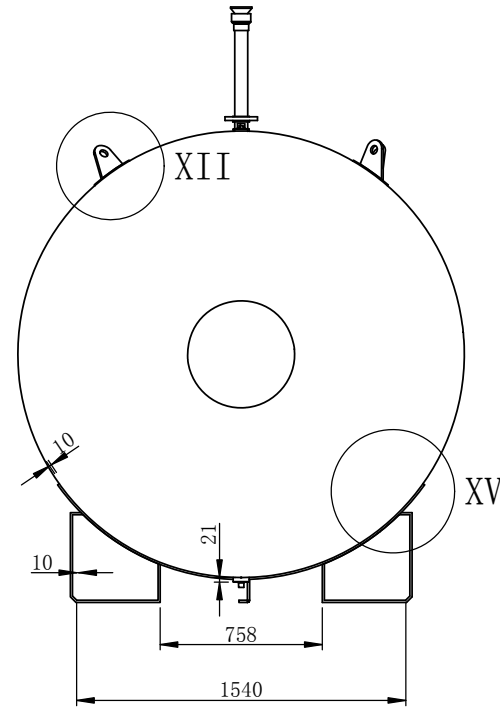
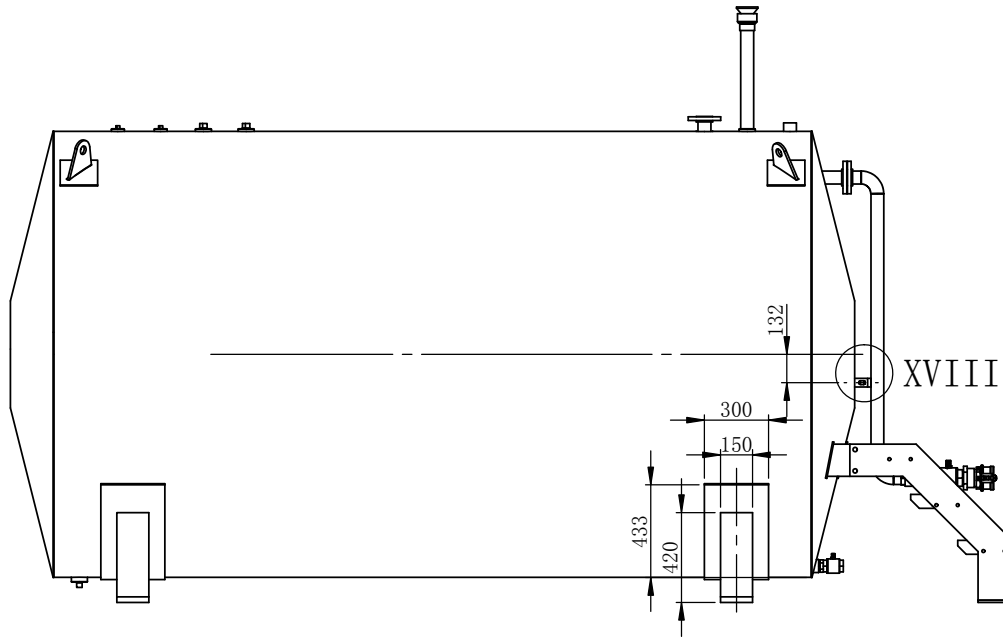

THIRD ANGLE PROJECTION	
COPYRIGHT © 206	
NAME	DATE
DRAWN	
CHK'D	
APP'VD	



TOLERANCE U.N.O.  
 0 = -1.0  
 0.0 = -0.4  
 0.00 = -0.1

DWG NO. / PART NO.  
**FAR-12**

**FAR 12,000L Safe Fill Level Single Wall Tank**

TITLE:  
 SCALE: N.T.S. SHEET 3 OF 3

SHEET SIZE  
**A3**  
 REVISION  
**01**

WEIGHT: 1017.74 Kg