



This manual contains important warnings and information.
READ AND KEEP FOR REFERENCE.

INSTRUCTIONS

First choice when quality counts.™

Air Regulator

*100 psi (.7 MPa, 7 bar) Maximum
Air Inlet Pressure*

Part No. 244719

3/4 in. npt(f) inlet and outlet

Part No. 244720

3/4 in. npt(f) inlet and outlet

Table of Contents

Warnings	2
Installation	2
Operation	4
Service	5
Parts	6
Technical Data	9
Graco Warranty	10
Toll-Free Graco Phone Number	10

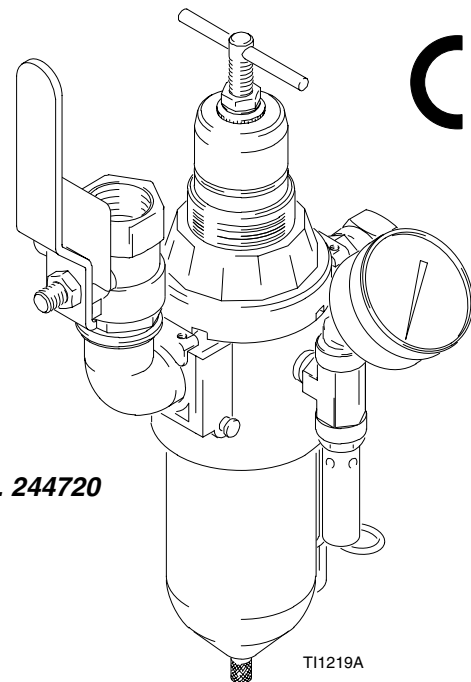
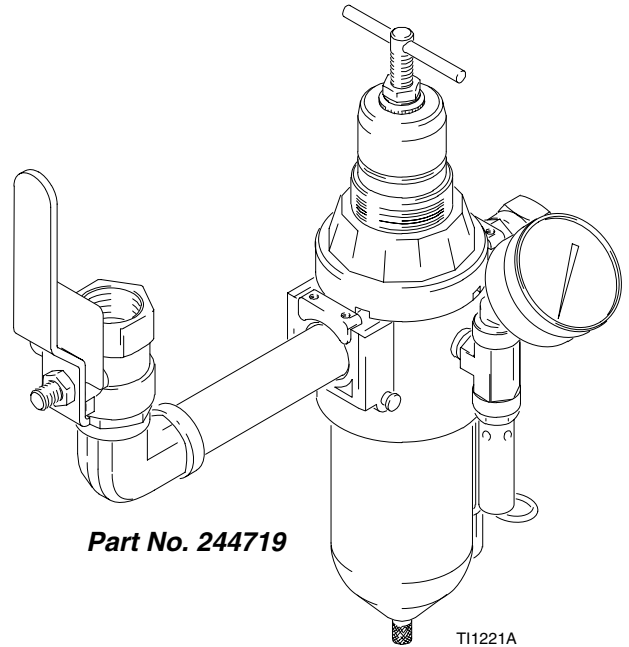

GRACO INC. P.O. BOX 1441 MINNEAPOLIS, MN 55440-1441

©COPYRIGHT 2001, GRACO INC.
Graco Inc. is registered to I.S. EN ISO 9001

Symbols

Warning Symbol



This symbol alerts you to the possibility of serious injury or death if you do not follow the instructions.

Caution Symbol



This symbol alerts you to the possibility of damage to or destruction of equipment if you do not follow the instructions.

WARNING



INSTRUCTIONS

EQUIPMENT MISUSE HAZARD

Equipment misuse can cause the equipment to rupture or malfunction and result in serious injury.

- This equipment is for professional use only.
- Read all instruction manuals, tags, and labels before operating the equipment.
- Use the equipment only for its intended purpose. If you are not sure, call your Graco distributor.
- Do not alter or modify this equipment.
- Check equipment daily. Repair or replace worn or damaged parts immediately.
- Follow the **Pressure Relief Procedure** on page 4 if the spray tip clogs and before cleaning, checking or servicing the equipment.
- Do not exceed the maximum working pressure of the lowest rated system component. Refer to the **Technical Data** on page 9 for the maximum working pressure of this equipment.
- Always wear protective eyewear when operating or servicing this equipment.
- Comply with all applicable local, state, and national fire, electrical, and safety regulations.

Installation

Prepare the Site

NOTE: Always use Genuine Graco Parts and Accessories, available from your Graco distributor. If you supply your own accessories, be sure they are adequately sized and pressure rated for your system.

Bring a compressed air supply line from the air compressor to the pump location. Be sure all air hoses are properly sized and pressure-rated for your system. Use only electrically conductive hoses. The air hose should have a 3/4 npsm(m) thread.

Before installing any air line components, blow out the air lines to remove scale and other debris. Use pipe compound or tape sparingly and only on male threads.

Install a bleed-type shutoff valve in the air line upstream from all other air line components, to isolate them for servicing.



Do not hang the air control kit directly off the pump air motor inlet, which could be damaged by the weight and operating stress. Use a bracket to mount the kit to a cart or to the wall.

Installation

Kit Components (see page 6)

WARNING

A bleed-type master air valve (5) is supplied. This valve relieves air trapped between it and the pump when the valve is closed, to help reduce the risk of serious injury, including fluid injection and splashing of fluid in the eyes or on the skin, and injury from moving parts if you are adjusting or repairing the pump.

- **The bleed-type master air valve (4)** is supplied to relieve air trapped between it and the air motor when the valve is closed (see the **WARNING** above). Be sure the bleed valve is easily accessible from the pump, and is located **downstream** from the air filter/regulator (1). Fig. 2.
- **The air filter/regulator (1)** controls pump speed and outlet pressure by adjusting the air pressure to the pump. It also removes harmful dirt and moisture from the compressed air supply. Locate the regulator as close as possible to the equipment it serves, but **upstream** from the bleed-type master air valve (4). Install the regulator in the air line so the air flow is in the direction of the arrow stamped on the body. Fig. 2.

Using the Pipe Port Inserts

To open the pipe port insert (A), remove the insert pin (S) and pull insert up in direction away from pin hole. Install new insert and reinsert pin. Fig.1.

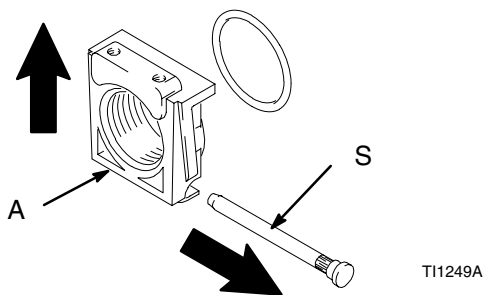

Fig. 1

Adding a Lubricator (Accessory)

To add an accessory air line lubricator to the kit, you must order Part No. 244841 Lubricator Accessory Kit.

1. Remove filter/regulator from mount bracket.
2. Remove the pin (B) from the outlet of the filter/regulator. Fig. 2

3. Remove regulator cover.
4. Slide the threaded end insert off (13) with outlet fittings still attached.
5. Install the modular connector (2a) (with o-rings and grease provided) between the filter/regulator and the lubricator (L).
6. Install the threaded end insert (13) onto the outlet of the lubricator (L) (with o-ring and grease).
7. Install the three retaining pins (B).

NOTE: On light weight cart units only, replace the 3/4" npt pipe extension and the 3/4" npt f x f elbow with the 3/4" npt f x m elbow supplied with kit 244841, refer to instructions (form 406512) included with kit.

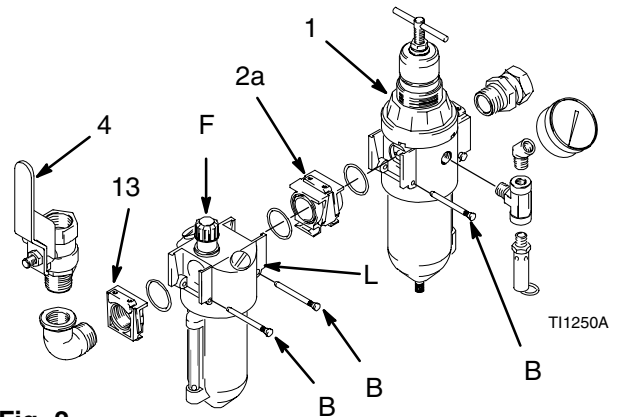

Fig. 2

The lubricator meters oil into the moving air stream to automatically lubricate air-operated motors. A manual adjustment in the housing (F), Fig. 2, sets the oil drip rate into the air stream, which can be monitored through a sight glass. One to two drops of oil per minute is common. Use an oil rated at 50 to 200 SUS (ISO grade 7 to 46) at 100°F (38°C), such as Graco motor oil, Part No. 202659.

WARNING

To reduce the risk of serious injury whenever you are instructed to relieve pressure, always follow the **Pressure Relief Procedure** on page 4.

To refill, unscrew the fill plug (L, Fig. 2) and pour in the oil. The lubricator's capacity is 7 oz. (0.2 liter). Check the oil level with the side sight glass. The lubricator can be refilled with the system pressurized. However, always **relieve the system pressure** before removing the bowl for any reason.

Operation

Pressure Relief Procedure

WARNING



INJECTION HAZARD

The system pressure must be manually relieved to prevent the system from starting or spraying accidentally. Fluid under high pressure can be injected through the skin and cause serious injury. To reduce the risk of an injury from injection, splashing fluid, or moving parts, follow the **Pressure Relief Procedure** whenever you:

- are instructed to relieve the pressure,
- stop spraying,
- check or service any of the system equipment,
- or install or clean the spray tips.

1. Lock the gun trigger safety.
2. Close all bleed-type master air valves, including the bleed-type master air valve (4), supplied in your system. Fig. 2.
3. Turn the regulator T-handle all the way counterclockwise if you are removing the air filter/regulator (1) bowl, or servicing the air filter/regulator.
4. Open any fluid shutoff valves.
5. Unlock the gun trigger safety.
6. Hold a metal part of the gun firmly to the side of a grounded metal pail, and trigger the gun to relieve pressure.
7. Lock the gun trigger safety.

8. Open any fluid drain valves (required in your system), having a container ready to catch the drainage.
9. Leave the drain valve(s) open until you are ready to spray again.

*If you suspect that the spray tip or hose is completely clogged, or that pressure has not been fully relieved after following the steps above, **very slowly** loosen the tip guard retaining nut or hose end coupling and relieve pressure gradually, then loosen completely. Now clear the tip or hose.*

Adjusting the Air Regulator

1. **To increase** the regulated air pressure, turn the T-handle **clockwise**.
2. **To decrease** the regulated air pressure, turn the T-handle **counterclockwise**.
3. To lock the regulator setting, tighten the jam nut.
4. Slowly open the air filter/regulator (1), Fig.2. Use the filter/regulator to control pump speed and fluid pressure. Always use the lowest air pressure necessary to get the desired results. Higher pressures cause premature tip and pump wear.

WARNING



COMPONENT RUPTURE HAZARD

To reduce the risk of overpressurizing your system, which could cause component rupture and serious injury, *never exceed the specified Maximum Incoming Air Pressure to the pump* (see the **Technical Data**, on page 9).

Service

Air Regulator Service

Repair Kits are available. Refer to page 6.

Every day, drain contaminants from the bowl before reaching the baffle level by opening the drain (D) at the bottom of the bowl (B). See Fig. 3.

WARNING

To reduce the risk of serious injury whenever you are instructed to relieve pressure, always follow the **Pressure Relief Procedure** on page 4.

Clean the air filter regularly to maximize filtering efficiency and to avoid excessive pressure drop. Fully **relieve pressure** to remove the bowl (B).

Clean the filter element and bowl using household soap and water or denatured alcohol. Use compressed air to blow out the filter body. Blow the filter element out from the inside.

If the regulator fails to operate, operates roughly, or vibrates, service it as follows.

Inspect all parts for wear or damage. Replace damaged parts.

Lubricate the bearing area, all o-rings, adjusting screw threads, and spring ends with no. 2 lithium-base grease. See. Fig. 3. Reassemble the regulator.

Lubricator Service (Accessory)

An accessory Lubricator Kit is available. Order Part No. 244841. Repair Kits are available (refer to page 7) for an accessory lubricator should you add one to the Air Control Kit.

Clean the lubricator regularly to maximize efficiency. Fully **relieve pressure** and remove the lubricator from the air line.

Disassemble the lubricator.

Clean the parts with household soap and water or denatured alcohol. Wipe dry with a clean, soft cloth. Use compressed air to blow dirt and contaminants out of the lubricator body.

Inspect all parts for wear or damage. Replace damaged parts.

Clean the sight glass (S) thoroughly. See Fig. 4. Do not leave solvent residue in the sight glass as it may attack or weaken the glass. If the sight glass appears damaged, replace it immediately.

Reassemble the lubricator.

Air Regulator Repair Kits

**Model 116521
Air Regulator
Shown**

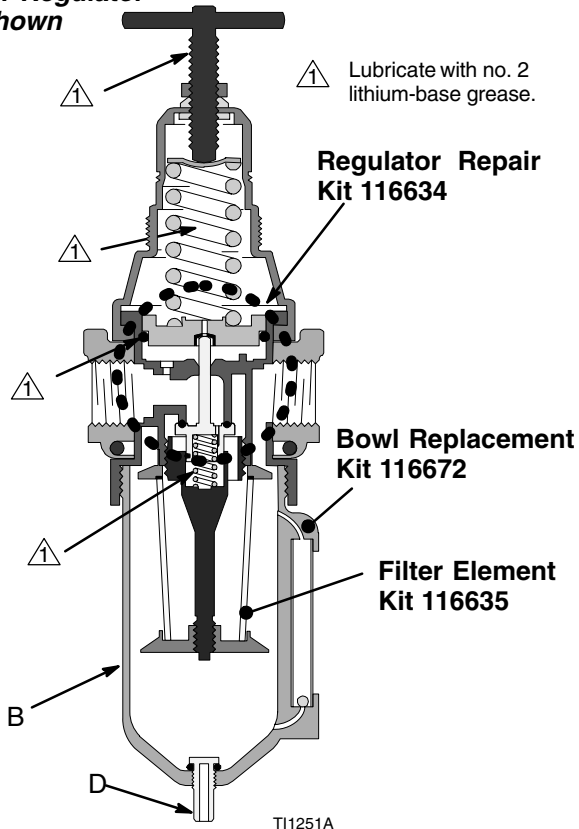

Fig. 3

Regulator Repair Kit 116634, for Part No. 116521 Air Filter/Regulator.
Individual parts are not available separately.

Bowl Replacement Kit 116672 for Part No. 116521 Air Filter/Regulator and Part No. C11034 Lubricator.

Individual parts are not available separately.

Note: this repair kit can be used for both the air regulator and the lubricator

Filter Element Kit 116635 for Part No. 116521 Air Filter/Regulator.

Individual parts are not available separately. Includes 40 micron filter.

Lubricator Repair Kits

Sight Dome Repair Kit 116670. For Part No. C11034 Lubricator.

Individual parts are not available separately.

Bowl Repair Kit 116672 for Part No. 116521 Air Filter/Regulator and Part No. C11034 Lubricator.

Individual parts are not available separately.

Note: this repair kit can be used for both the lubricator and the air regulator.

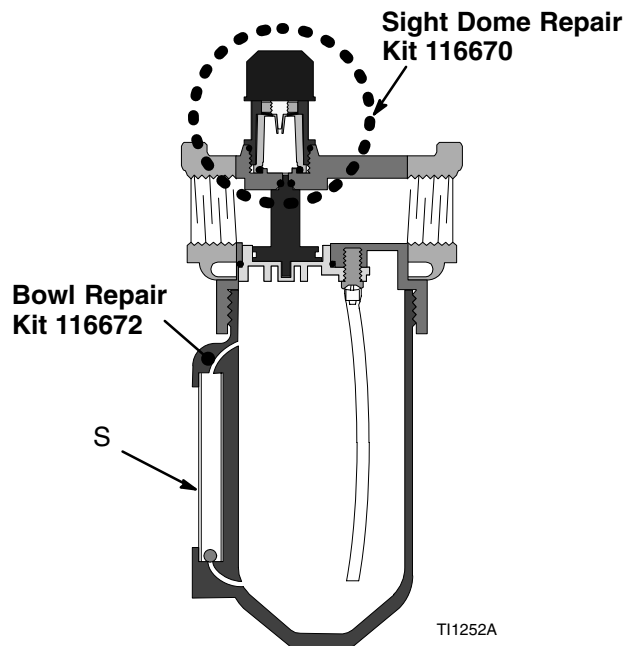
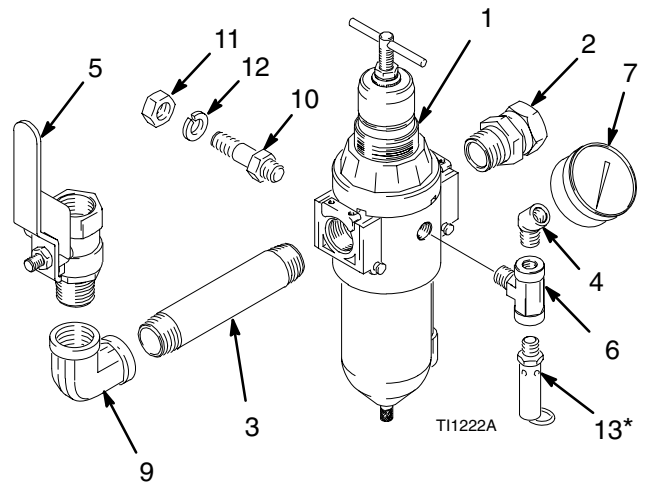

Fig. 4

Air Control Parts

Part No. 244719, Series A (includes items 1 to 12 – does not include Ref. No. 13)

Ref. No.	Part No.	Description	Qty.
1	116521	AIR FILTER/REGULATOR; 3/4 npt(f) inlet and outlet; 5–125 psi (.03–0.86 MPa, 0.3–8.6 bar) pressure range; 40 micron polypropylene filter	1
2		UNION, swivel; 3/4 npt(m) x 3/4 npsm(f)	1
3		NIPPLE, pipe 3/4 npt x 4 in.	1
4		ELBOW, street, 45°; 1/4 npt (m x f)	1
5	113218	BALL VALVE, vented; 3/4 npt (m x f)	1
6		TEE, pipe 1/4 npt	1
7	101689	GAUGE, air pressure	1
9		ELBOW, street, 90°; 3/4 npt (f x f)	1
10	194545	CONNECTOR, bulkhead	1
11		NUT, keps, hex, 8mm	1
12		WASHER, lock 8mm	1
13*		VALVE, safety relief	



Part No. 244720, Series A (includes items 1 to 11 – does not include Ref. No. 12)

Ref. No.	Part No.	Description	Qty.
1	116521	AIR FILTER/REGULATOR; 3/4 npt(f) inlet and outlet; 5–125 psi (.03–0.86 MPa, 0.3–8.6 bar) pressure range; 40 micron polypropylene filter	1
2		UNION, swivel; 3/4 npt(m) x 3/4 npsm(f)	1
3		ELBOW, street, 90°	1
4	113218	BALL VALVE, vented; 3/4 npt (m x f)	1
5		TEE, pipe 1/4 npt	1
6		ELBOW, street 1/4 npt (m x f)	1
7	101689	GAUGE, air pressure	1
9	194545	CONNECTOR, bulkhead	1
10		NUT, hex, 8mm	1
11		WASHER, lock 8mm	1
12*		VALVE, safety relief	

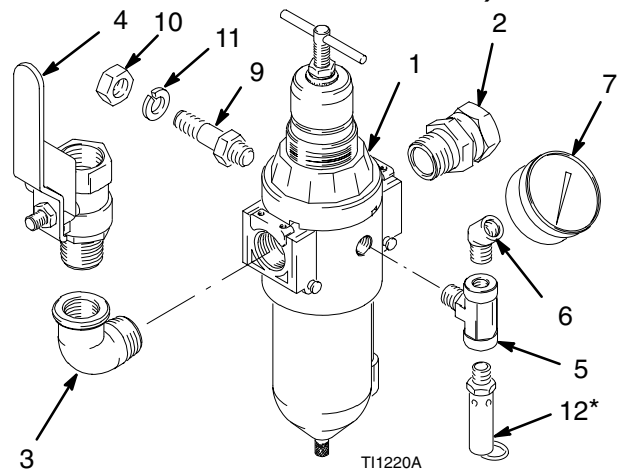

* not included in Air Control Kit Part No. 244719 or 244720. Replace with appropriate Part No. from table below according to pump ratio.

Pump Ratio	Part No.	Description	Pressure Relief
80:1 King	116643	Safety Relief Valve	90 psi
56:1 King	103347	Safety Relief Valve	100 psi
24:1 Bulldog 33:1 Bulldog 41:1 Bulldog 45:1 King 68:1 King	113498	Safety Relief Valve	110 psi

Lubricator Conversion Kit Parts

Part No. 244841, Series A, (includes items 1 to 3)

Ref. No.	Part No.	Description	Qty.
1	C11034	LUBRICATOR, Air	1
2	116522	AIR CONTROL, conversion kit (includes items 2a – 2c)	1
2a		ADAPTER	1
2b		PINS, retaining	2
2c		O-RINGS	2
3		ELBOW, street, 90°, 3/4 NPT (m x f)	1

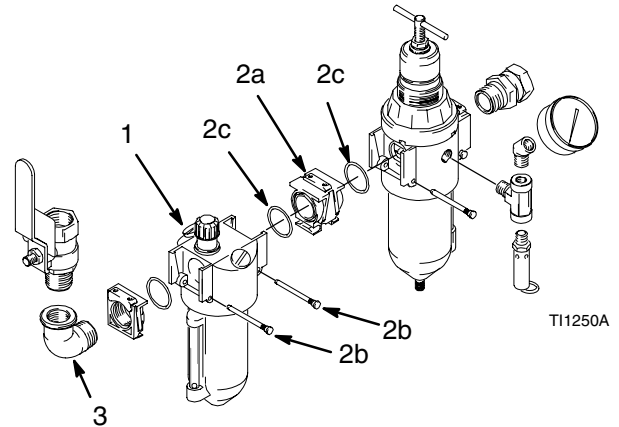

Technical Data

Model 116521 Air Regulator

Category	Data
Maximum air input pressure	250 psi (1.7 MPa, 17.2 bar)
Air inlet size	3/4 npsm(f)
Air outlet size	3/4 npt(f)
Gauge port size (air regulator)	1/4 npt(f)
Air filter element	40 micron polypropylene screen
Maximum operating temperature	50°C (122°F)

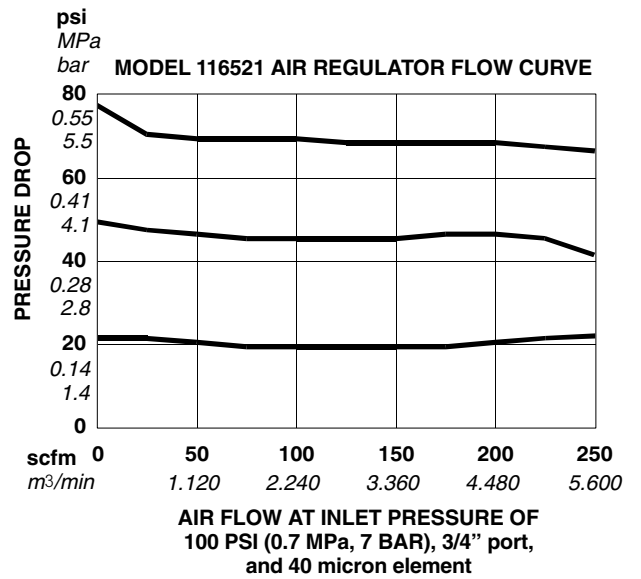

The Graco Standard Warranty

Graco warrants all equipment manufactured by Graco and bearing its name to be free from defects in material and workmanship on the date of sale by an authorized Graco distributor to the original purchaser for use. With the exception of any special, extended, or limited warranty published by Graco, Graco will, for a period of twelve months from the date of sale, repair or replace any part of the equipment determined by Graco to be defective. This warranty applies only when the equipment is installed, operated and maintained in accordance with Graco's written recommendations.

This warranty does not cover, and Graco shall not be liable for general wear and tear, or any malfunction, damage or wear caused by faulty installation, misapplication, abrasion, corrosion, inadequate or improper maintenance, negligence, accident, tampering, or substitution of non-Graco component parts. Nor shall Graco be liable for malfunction, damage or wear caused by the incompatibility of Graco equipment with structures, accessories, equipment or materials not supplied by Graco, or the improper design, manufacture, installation, operation or maintenance of structures, accessories, equipment or materials not supplied by Graco.

This warranty is conditioned upon the prepaid return of the equipment claimed to be defective to an authorized Graco distributor for verification of the claimed defect. If the claimed defect is verified, Graco will repair or replace free of charge any defective parts. The equipment will be returned to the original purchaser transportation prepaid. If inspection of the equipment does not disclose any defect in material or workmanship, repairs will be made at a reasonable charge, which charges may include the costs of parts, labor, and transportation.

THIS WARRANTY IS EXCLUSIVE, AND IS IN LIEU OF ANY OTHER WARRANTIES, EXPRESS OR IMPLIED, INCLUDING BUT NOT LIMITED TO WARRANTY OF MERCHANTABILITY OR WARRANTY OF FITNESS FOR A PARTICULAR PURPOSE.

Graco's sole obligation and buyer's sole remedy for any breach of warranty shall be as set forth above. The buyer agrees that no other remedy (including, but not limited to, incidental or consequential damages for lost profits, lost sales, injury to person or property, or any other incidental or consequential loss) shall be available. Any action for breach of warranty must be brought within two (2) years of the date of sale.

Graco makes no warranty, and disclaims all implied warranties of merchantability and fitness for a particular purpose in connection with accessories, equipment, materials or components sold but not manufactured by Graco. These items sold, but not manufactured by Graco (such as electric motors, switches, hose, etc.), are subject to the warranty, if any, of their manufacturer. Graco will provide purchaser with reasonable assistance in making any claim for breach of these warranties.

In no event will Graco be liable for indirect, incidental, special or consequential damages resulting from Graco supplying equipment hereunder, or the furnishing, performance, or use of any products or other goods sold hereto, whether due to a breach of contract, breach of warranty, the negligence of Graco, or otherwise.

FOR GRACO CANADA CUSTOMERS

The parties acknowledge that they have required that the present document, as well as all documents, notices and legal proceedings entered into, given or instituted pursuant hereto or relating directly or indirectly hereto, be drawn up in English. Les parties reconnaissent avoir convenu que la rédaction du présente document sera en Anglais, ainsi que tous documents, avis et procédures judiciaires exécutés, donnés ou intentés à la suite de ou en rapport, directement ou indirectement, avec les procédures concernées.

Graco Phone Number

TO PLACE AN ORDER, contact your Graco distributor, or call this number to identify the distributor closest to you:

1-800-367-4023 Toll Free

612-623-6921

612-378-3505 Fax

*All written and visual data contained in this document reflects the latest product information available at the time of publication.
Graco reserves the right to make changes at any time without notice.*

Sales Offices: Minneapolis, Detroit

International Offices: Belgium, Korea, Hong Kong, Japan

GRACO INC. P.O. BOX 1441 MINNEAPOLIS, MN 55440-1441

www.graco.com

PRINTED IN USA 309341 June 2001