

Displacement Pump

310643W

EN

Use only genuine Graco replacement parts. Use of non-Graco replacement parts may void warranty.

3300 psi (22.7 MPa, 227 bar) Maximum Working Pressure



Important Safety Instructions

Read all warnings and instructions in this manual. Be familiar with the controls and the proper usage of the equipment. Save these instructions.

Model 248204, Series A

UltraMax II and Ultimate MX II 695/795
ASM Zip-Spray 2700 Plus, 3100 Plus
ASM AllPro Mach 8600 Plus and 11000 Plus
ASM H2700 Plus

Model 255968, Series A

ASM 3600G Plus

Model 248205, Series A

UltraMax II and Ultimate MX II 1095/1595

Model 249059, Series A

TexSpray Mark V

Model 249057, Series A

TexSpray Mark V

Model 277069, Series A

LineLazer 3900, ES2000

Model 277070, Series A

LineLazer 5900

Model 253056, Series A

Mark IV

Model 257146, Series A

Ironman 300E and Ironman 500G

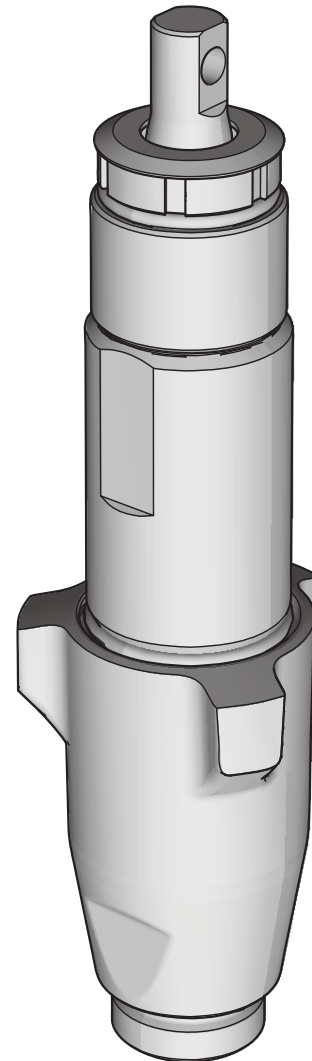









ti2311

Table of Contents

Warnings	2	Parts - Pump 253056	16
Service	3	Technical Data	17
Parts - Pump 248204, 277069, 255968	14	Graco Standard Warranty	1
Parts - Pump 248205, 249057, 249059, 277070, 257146	15		

Warnings

The following warnings are for the setup, use, grounding, maintenance, and repair of this equipment. The exclamation point symbol alerts you to a general warning and the hazard symbols refer to procedure-specific risks. When these symbols appear in the body of this manual or on warning labels, refer back to these Warnings. Product-specific hazard symbols and warnings not covered in this section may appear throughout the body of this manual where applicable.

 WARNING	
 	<p>EQUIPMENT MISUSE HAZARD</p> <p>Misuse can cause death or serious injury.</p> <ul style="list-style-type: none"> • Do not exceed the maximum working pressure or temperature rating of the lowest rated system component. See Technical Data in all equipment manuals. • Use fluids and solvents that are compatible with equipment wetted parts. See Technical Data in all equipment manuals. Read fluid and solvent manufacturer’s warnings. For complete information about your material, request MSDS from distributor or retailer. • Turn off all equipment and follow the Pressure Relief Procedure when equipment is not in use. • Check equipment daily. Repair or replace worn or damaged parts immediately with genuine manufacturer’s replacement parts only. • Do not alter or modify equipment. Alterations or modifications may void agency approvals and create safety hazards. • Use equipment only for its intended purpose. Call your distributor for information. • Do not use 1,1,1-trichloroethane, methylene chloride, other halogenated hydrocarbon solvents or fluids containing such solvents. • Comply with all applicable safety regulations.
 	<p>MOVING PARTS HAZARD</p> <p>Moving parts can pinch, cut or amputate fingers and other body parts.</p> <ul style="list-style-type: none"> • Keep clear of moving parts. • Do not operate equipment with protective guards or covers removed. • Pressurized equipment can start without warning. Before checking, moving, or servicing equipment, follow the Pressure Relief Procedure and disconnect all power sources.
  	<p>SKIN INJECTION HAZARD</p> <p>High-pressure spray is able to inject toxins into the body and cause serious bodily injury. In the event that injection occurs, get immediate surgical treatment.</p> <ul style="list-style-type: none"> • Do not aim the gun at, or spray any person or animal. • Keep hands and other body parts away from the discharge. For example, do not try to stop leaks with any part of the body. • Always use the nozzle tip guard. Do not spray without nozzle tip guard in place. • Do not leave the unit energized or under pressure while unattended. When the unit is not in use, turn off the unit and follow the Pressure Relief Procedure for turning off the unit. • Always engage the trigger lock when not spraying. Verify the trigger lock is functioning properly.

Service

Pressure Relief Procedure



Follow the Pressure Relief Procedure whenever you see this symbol.

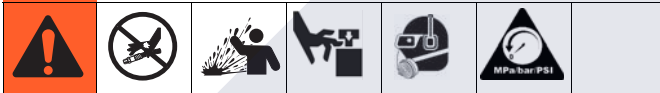

This equipment stays pressurized until pressure is manually relieved. To help prevent serious injury from pressurized fluid, such as skin injection, splashing fluid and moving parts, follow the Pressure Relief Procedure when you stop spraying and before cleaning, checking, or servicing the equipment.

1. Engage trigger lock.
2. Turn ON/OFF switch to OFF.
3. Unplug power cord.
4. Disengage trigger lock. Hold metal part of gun against grounded metal pail and trigger gun into pail to relieve pressure.
5. Engage the trigger lock.
6. Open all fluid drain valves in the system, having a waste container ready to catch drainage. Leave drain valve(s) open until you are ready to spray again.
7. If you suspect the spray tip or hose is clogged or that pressure has not been fully relieved after following the steps above, **VERY SLOWLY** loosen tip guard retaining nut or hose end coupling to relieve pressure gradually, then loosen completely. Clear hose or tip obstruction.

Pump Repair Kits

Pump	Repair Kit
248204, 255968	248212
253056	287825
248205, 249057, 249059, 257146	248213

Tools Needed

- Vise
- 12 in. adjustable, open-end wrench (2)
- Hammer (20 oz maximum)
- Small screwdriver
- Throat Seal Liquid
- Pick or long small screwdriver

Cleaning and Inspecting Parts

Clean and inspect parts. Pay particular attention to the ball seats in the intake valve and piston, which must have no nicks or wear, and to the inside of the sleeve and the outside of the piston rod, which must not be worn or scratched. Replace worn or damaged parts.



COMPONENT RUPTURE HAZARD

To reduce the risk of serious injury from pressurized fluid, never use sharp or pointed tools to remove sleeve. If the sleeve cannot be removed easily, return the sleeve and cylinder to a Graco distributor for removal.

NOTE: Remove and clean sleeve when repacking pump.

Repair When Pump is Separated From Sprayer

Disassembling the Pump

1. Remove packing nut (202) and o-ring (228).

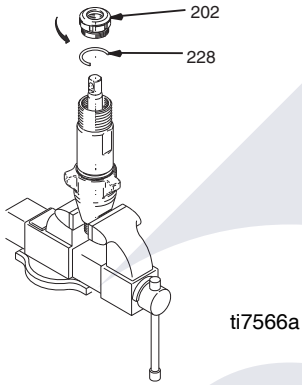

2. Unscrew intake valve from cylinder.

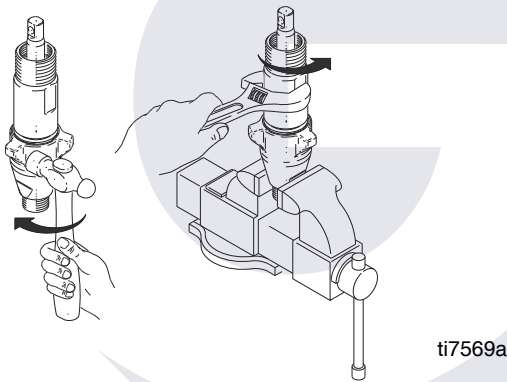

3. Disassemble intake valve. Clean and inspect o-ring (227). **NOTE:** A pick may be required to remove o-ring.

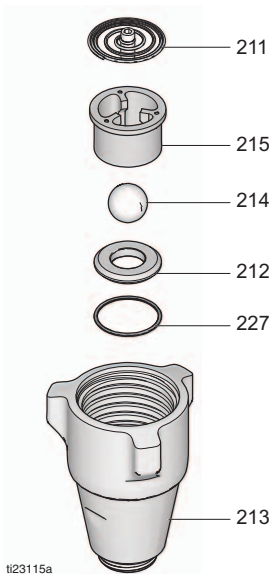

4. Tap piston rod out of cylinder with a hammer or flip over and tap piston rod out against a bench.

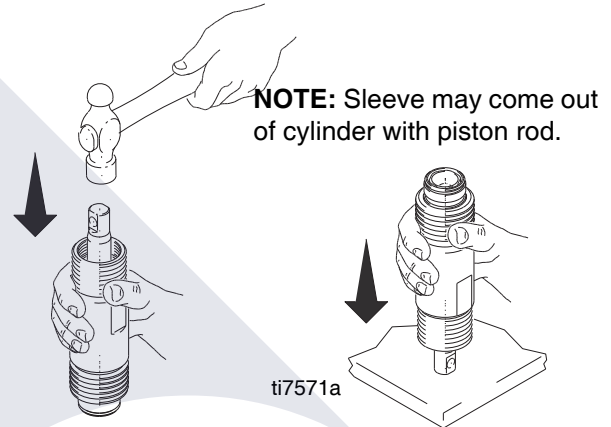

5. Remove piston rod from sleeve, or remove sleeve from cylinder. **Mark IV models:** Remove sleeve spacer (230) from sleeve.

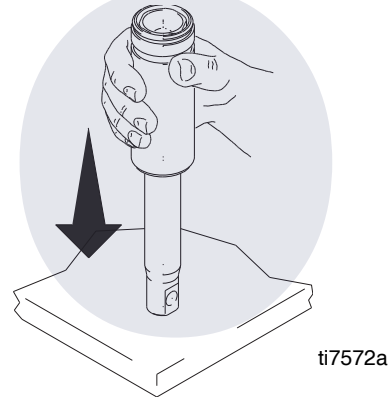



COMPONENT RUPTURE HAZARD

To reduce the risk of serious injury from pressurized fluid, do not clean or wipe the piston valve threads. Cleaning the piston valve threads could destroy the special sealing patch and cause the piston valve to come loose during operation.

6. Unscrew piston valve from piston rod. Clean and inspect parts. The piston has a special thread locking/sealing patch. Do not remove the patch. The patch allows four disassembly/assembly procedures before it is necessary to apply thread sealant to the threads.

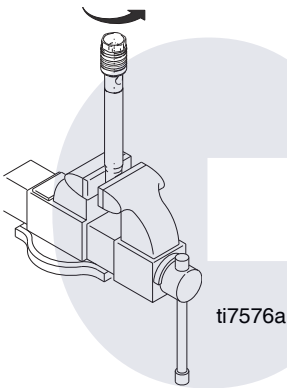

7. Remove packings and glands from piston rod.

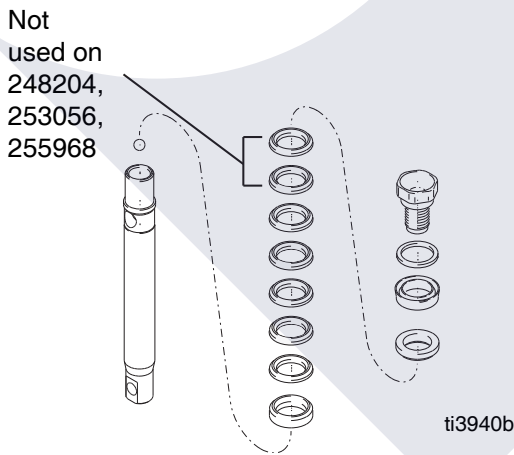

8. Remove throat packings and glands from cylinder. Discard throat packings and glands.

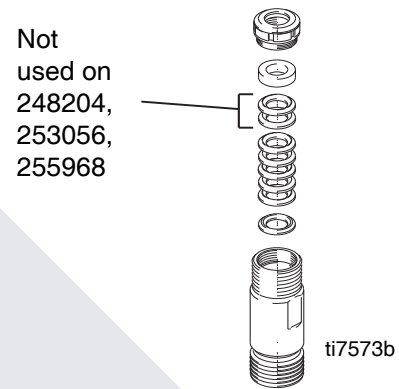

Assembling the Pump

1. Soak all leather packings in SAE 30W oil for 1 hour minimum prior to assembly. Stack male gland (204) on piston rod. Alternately stack UHMWPE (208) and leather (218) packings (note orientation) on piston rod. Install female gland (217). Install piston wiper (216) (note orientation) and backup washer (229) on piston valve (210). Threads are good for four repackings. Use thread sealant on piston valve threads after four repackings.

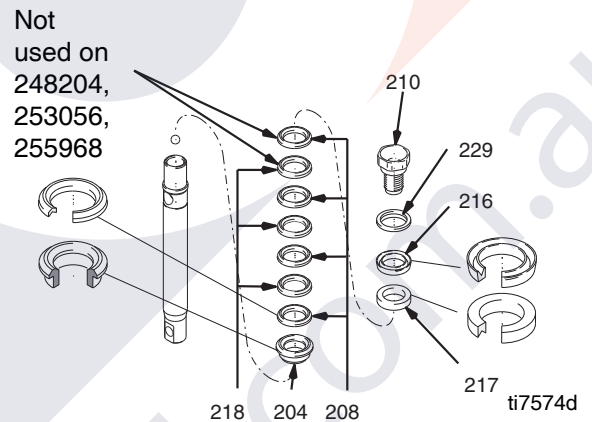

- Install ball (206) in piston rod. If thread sealant is applied to piston valve threads, make sure that none gets on ball.

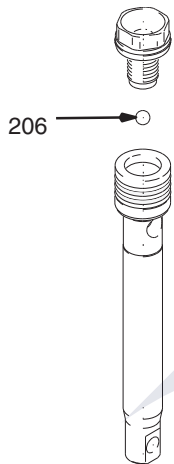

- Soak all leather packings in SAE 30W oil for one hour minimum prior to assembly. Place male gland (204) in cylinder. Alternately stack UHMWPE (203) and leather packings (223) (note orientation). Place female gland (224) in top of cylinder seat packings.

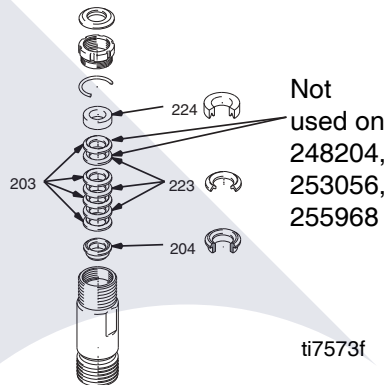

- Tighten piston valve to piston rod as specified:

Models	Torque
248204, 253056, 255968, 244069	27 +/-3 ft-lb.(36.1 +/-4.1 N•m)
248205, 249057, 249059, 277070, 257146	55 +/-3 ft-lb.(74.6 +/-4.1 N•m)

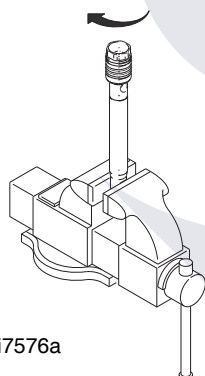

- Install seal (201) into packing nut (202). Install o-ring (228) onto packing nut. Loosely install packing nut into cylinder.

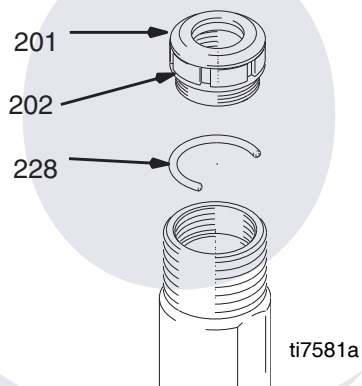

- Grease piston packings.

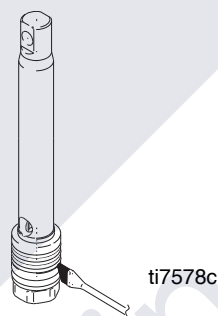

NOTICE
Do not slide piston assembly into top of sleeve as this may damage piston packing.

7. Slide piston assembly into bottom of sleeve.

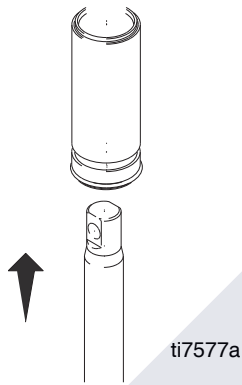

8. Grease top inch or two of piston rod that will go through the cylinder throat packings.

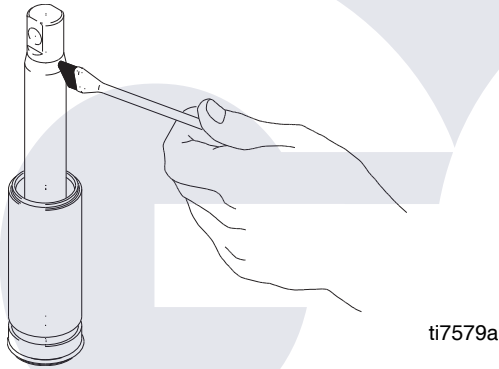

9. Grease o-rings (221) and place on sleeve. Slide sleeve/piston rod assembly into bottom of cylinder. Replace o-ring (207) if desired.

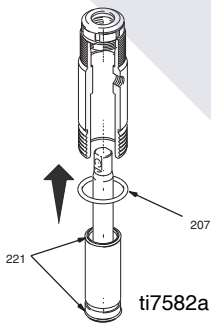

NOTE: O-ring (207) is not required for safe pump operation.

10. **Mark IV models:** Install o-ring (231) on sleeve spacer (230) and install sleeve spacer on sleeve.

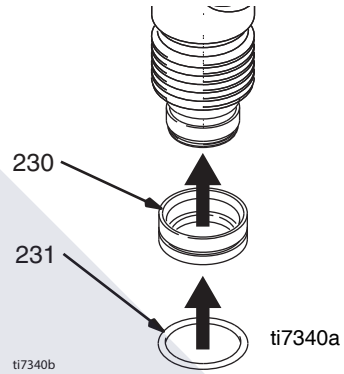

11. Reassemble intake valve with new o-ring (227), seat (212) and ball (214). Seat may be flipped over and used on other side. Clean seat thoroughly.

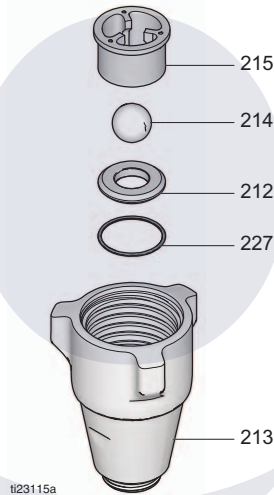

12. Install intake valve on cylinder. If a wrench is used torque as follows:

Models	Torque
248204, 253056, 255968, 277069	67 +/- 5 ft-lb (90.8 +/-6.8 N•m)
248205, 249057, 249059, 277070, 257146	80 +/- 5 ft-lb (108.5 +/-6.8 N•m)

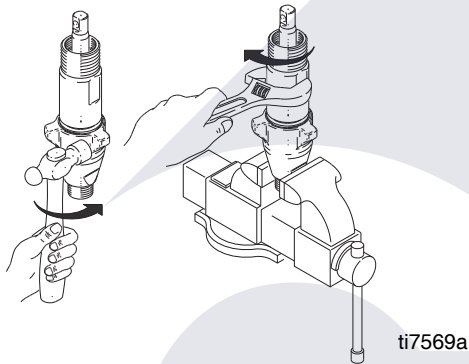

13. Torque packing nut (202) down onto adjustment spacer (228) 100 +/- 10 in-lb. (11.3 +/- 1.1 N•m)

14. Remove o-ring (228) when pump packings begin to leak after extended use. Then tighten packing nut down until leakage stops or lessens. This allows approximately 100 gallons of additional operation before a repacking is required.

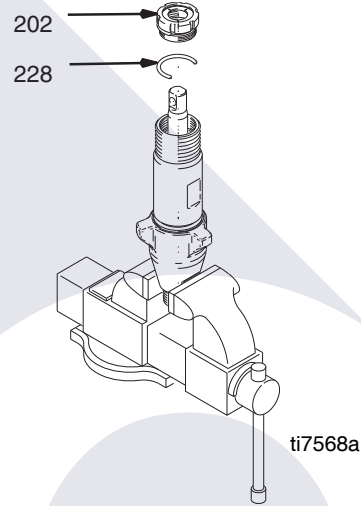

goind.com.au

Repair When Pump is On Sprayer



1. Perform **Pressure Relief Procedure**, page 3.
2. Remove intake valve.

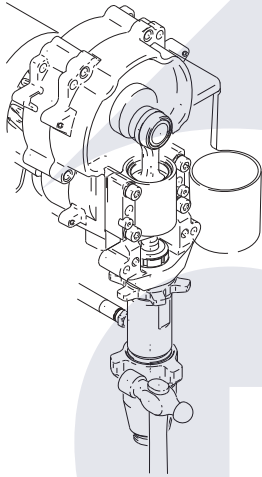

ti4258c

3. Push up retaining spring (26).

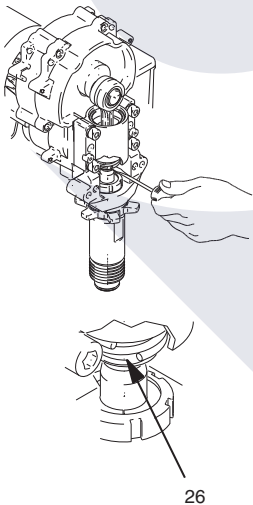

ti4258a

4. Push out pin (29).

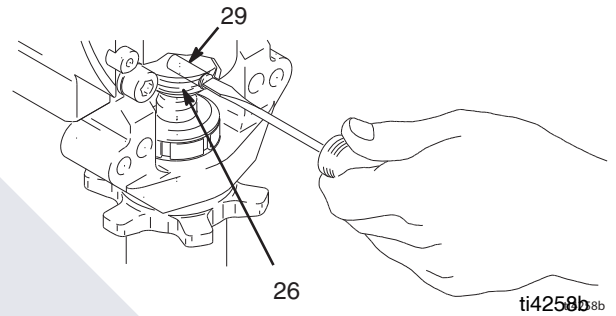

ti4258b

5. Disassemble intake valve. Clean and inspect. O-ring (227) may require a pick for removal.

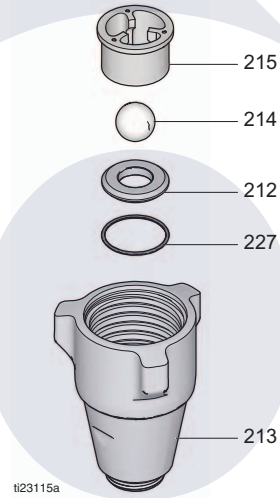

ti23115a

6. Remove piston rod and sleeve.

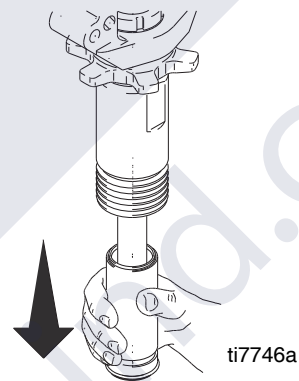

ti7746a

7. Invert piston rod and sleeve and pound on hard surface until piston rod comes out of sleeve.
Mark IV models: Remove sleeve spacer from sleeve.

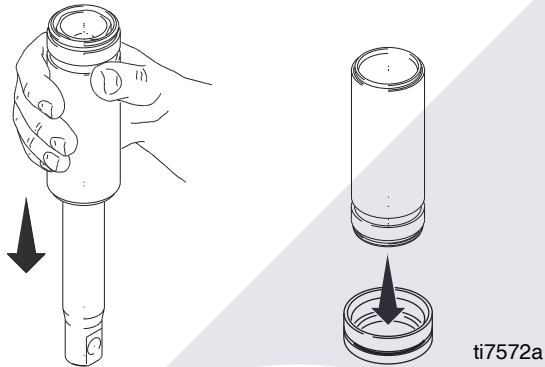

8. Remove packing nut (202).

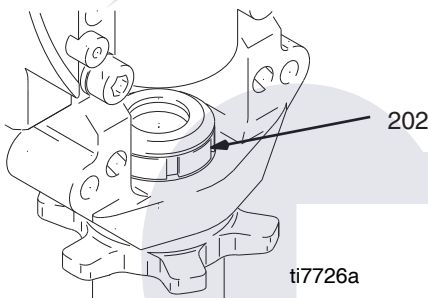

9. Invert piston rod and insert into cylinder to force out throat packings.

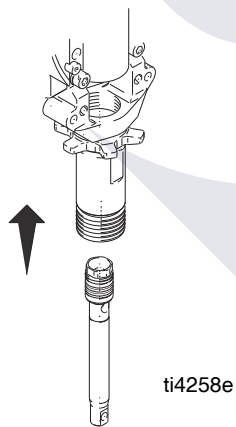

10. Insert piston rod into cylinder with pin hole up and piston valve down. Insert pin into piston rod and crank shaft.

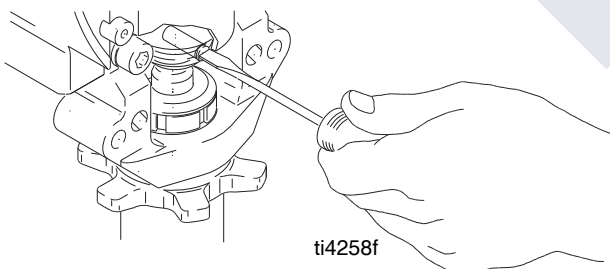

11. Remove piston valve from piston rod with a wrench.

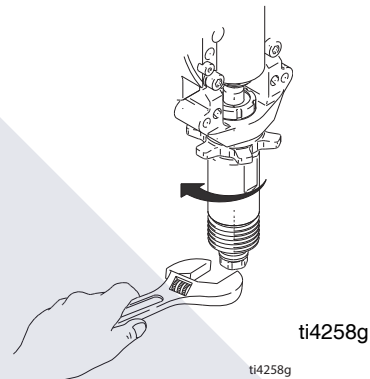

12. Remove pin and piston rod from cylinder.

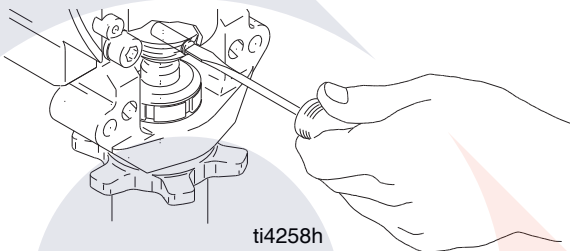

13. Soak all leather packings in SAE 30W oil for 1 hour minimum prior to assembly. Stack male gland (204). Alternately stack UHMWPE (203) and leather (223) packings (note orientation). Install female gland (224). Install seal (201) and packing nut (202) and o-ring (228).

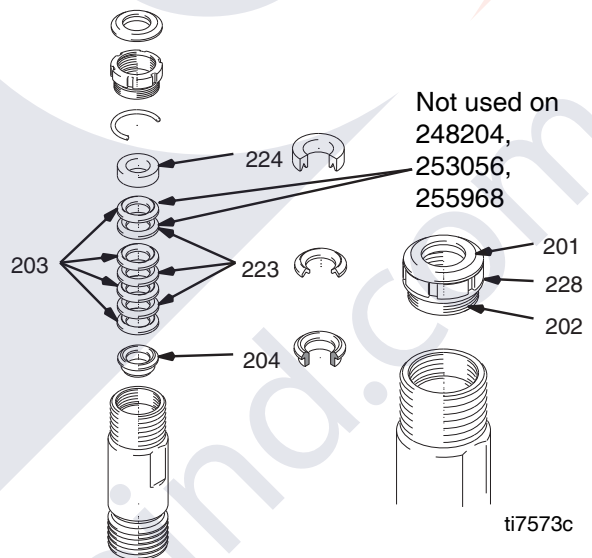

14. Remove packings and glands from piston rod.

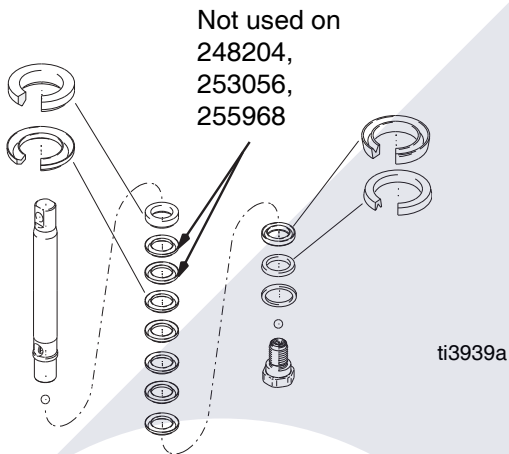

16. Install ball (206) in piston rod. **NOTE:** If thread sealant is applied to piston valve threads, make sure none gets on ball. Install piston valve on piston rod. Torque as follows:

Models	Torque
248204, 253056, 255968, 277069	27 +/- 3 ft-lb (36.6 +/-4.1 N•m)
248205, 249057, 249059, 277070, 257146	55 +/- 3 ft-lb (74.6 +/-4.1 N•m)

15. Soak all leather packings in SAE 30W oil for one hour minimum prior to assembly. Stack male gland (219) on piston rod. Alternately stack UHMWPE (208) and leather (218) packings (note orientation) on piston rod. Install female gland (217). Install piston wiper (216) and backup washer (229) (note orientation) on piston valve (210). The special sealing patch on piston valve threads is good for four repackings. Use thread sealant on piston valve threads after four repackings.

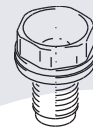
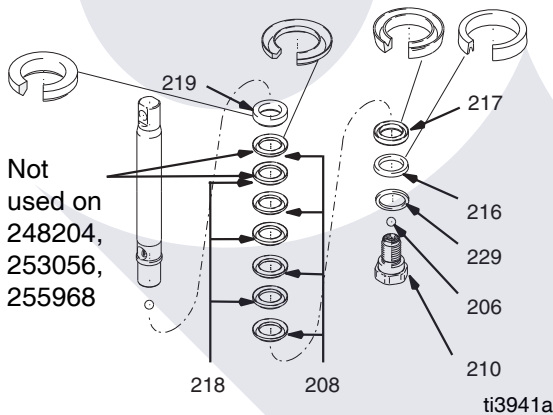

206



17. Grease piston packings.

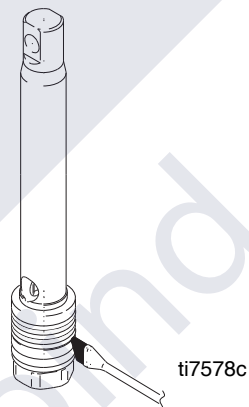

NOTICE

Do not slide piston assembly into top of sleeve as this may damage piston packing.

18. Slide piston assembly into bottom of sleeve. Make sure V-packing and u-cup are not rolled over or damaged. **Mark IV models:** Install o-ring (231) on sleeve spacer (230). Install sleeve spacer on sleeve.

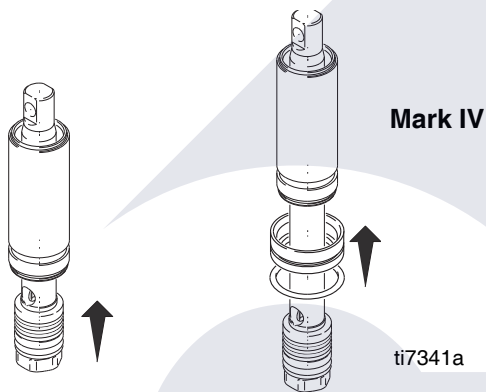

19. Grease top inch or two of piston rod that will go through the cylinder throat packings.

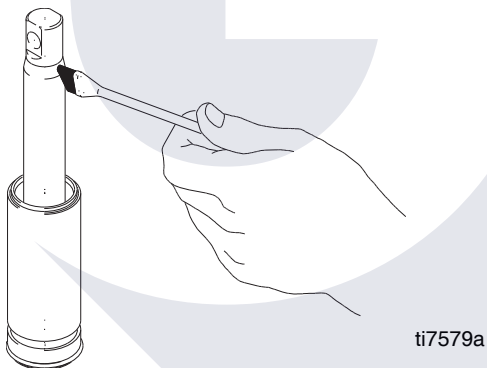

20. Grease o-ring (221) and place on sleeve. Slide sleeve/piston rod assembly into bottom of cylinder. Replace o-ring (207) if desired. **NOTE:** O-ring (207) is not required for safe pump operation.

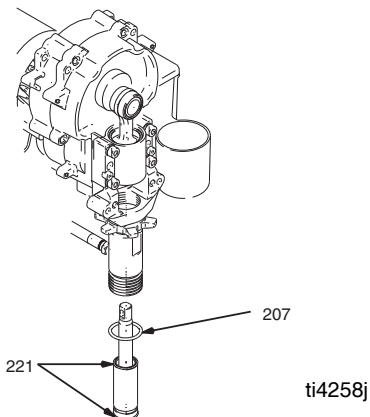

21. Torque seal and packing nut (202) down onto throat adjustment spacer (228) to 100 +/- 10 in-lb (11.3 +/- 1.1 N•m).

Remove o-ring when pump packings begin to leak after extended use. Then tighten packing nut down until leakage stops or reduces. This allows approximately 100 gallons of additional operation before a repacking is required.

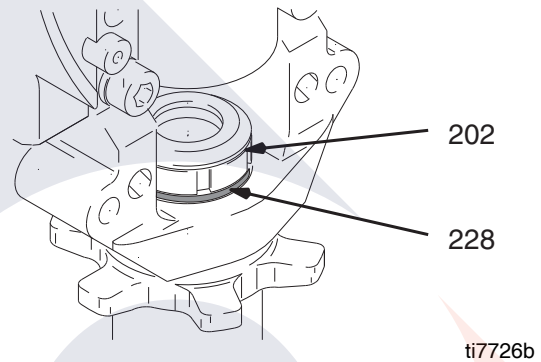

22. Push up retaining spring (26) with screwdriver.

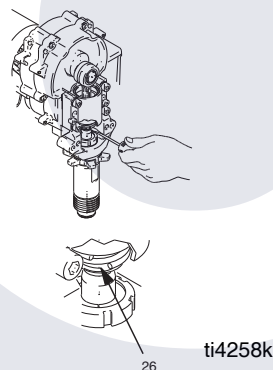

23. Push in pin (29). **NOTE:** Make sure retaining ring falls into slot.

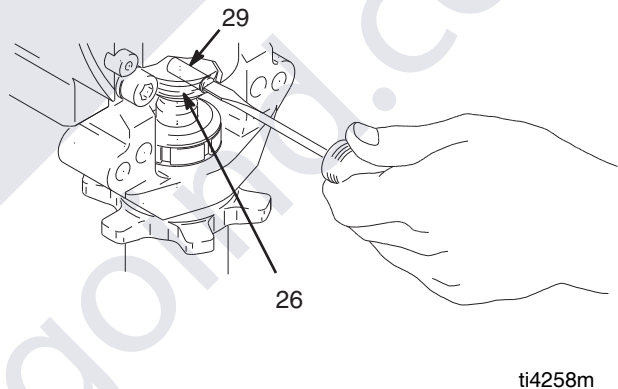

24. Reassemble intake valve with new o-rings (227) and (230), seat (212) and ball (214). Seat may be flipped over and used on other side. Clean seat thoroughly.

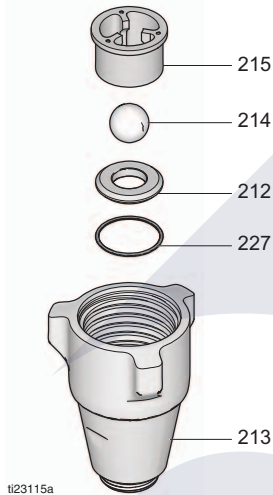

25. Install intake valve on cylinder. Torque as follows:

Models	Torque
248204, 253056, 255968, 277069	70 +/- 5 ft-lb (94.9 +/-6.8 N•m)
248205, 249057, 249059, 277070, 257146	80 +/- 5 ft-lb (108.5 +/-6.8 N•m)

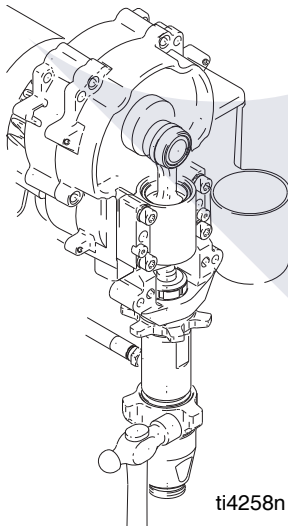

Pump Packings

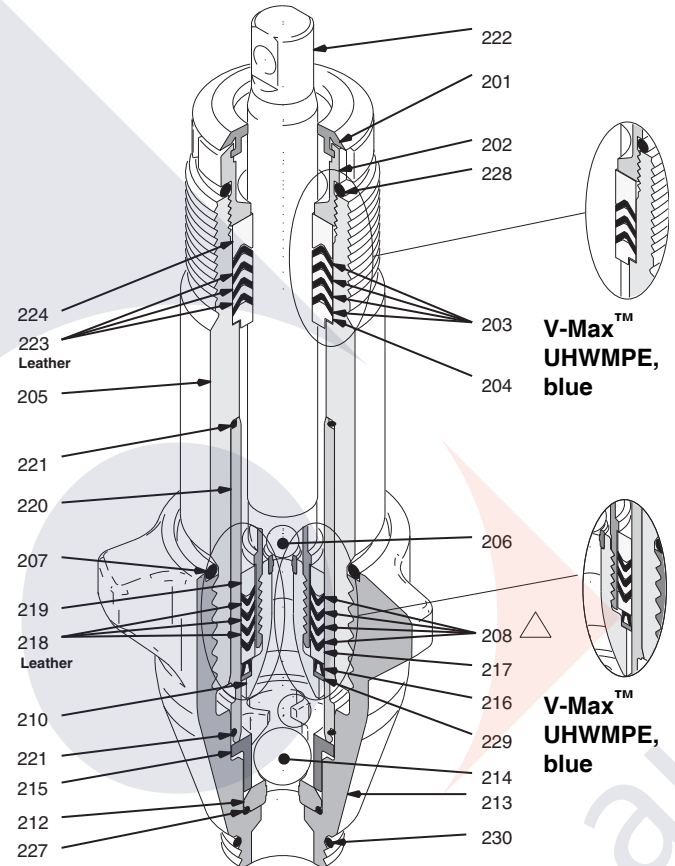

Pump 248204

ti7683d

Parts - Pump 248204, 277069, 255968

Series A

Ref.	Part	Description	Qty.
201	179810	SEAL, throat	1
202	193046	NUT, packing	1
203*	192692	V-PACKING, throat, V-Max, UHMWPE, blue	3
204*	15C987	GLAND, male, throat, CYLINDER, pump	1
205	243346	Model 248204, 255968	1
	243346	Model 16X428	1
206*	105444	BALL, sst, 0.3125 in.	1
207*	114054	PACKING, o-ring	1
208*	192693	V-PACKING, piston, V-MAX, UHMWPE, blue	3
210	239932	VALVE, piston	1
212†	239922	KIT, seat, carbide (includes 214 and 227)	1
213		VALVE, intake (foot)	1
	15C785	Model 248204, 255968	
	195892	Model 277069	
214*†	105445*	BALL, sst, 0.5000 in.	1
215	192624	GUIDE, ball	1
216*	118503	WIPER, piston	1
217*	178969	GLAND, female, piston	1
218*	178939	V-PACKING, leather, piston	2
219*	196880	GLAND, male	1
220	248209	SLEEVE, cylinder	1
221*	108526	O-RING, ptfе	2
222	248206	ROD, piston	1
223*	178940	V-PACKING, leather, throat	2
224*	15C988	GLAND, female	
227*†	107079	PACKING, o-ring	1
228	192714	SPACER, throat, nut	1
229*	15C997	WASHER, backup	1
230*	118494	O-RING, fluoroelastomer (not used on Lo-Boy)	1

* These parts are also included in Repair Kit 248212, which may be purchased separately.

† These parts are also included in Carbide Seat Kit 239922, which may be purchased separately.

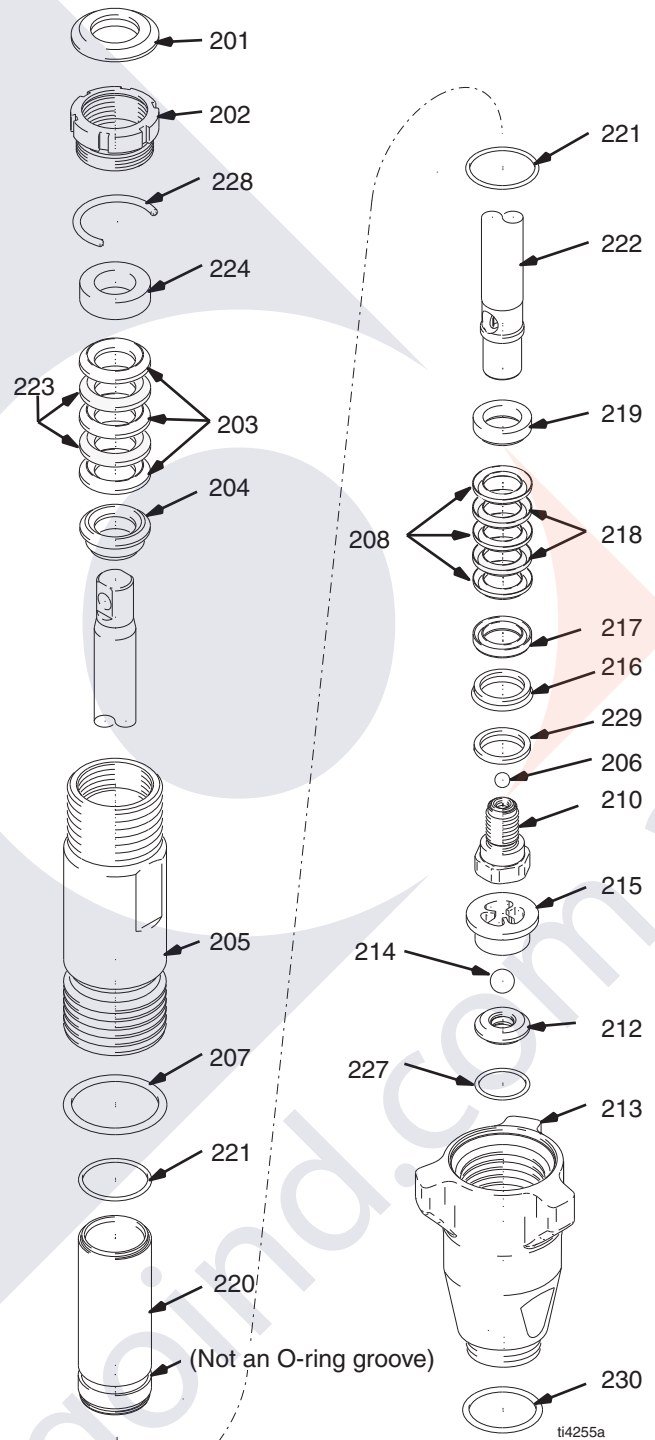

Parts - Pump 248205, 249057, 249059, 277070, 257146

Series A

Ref.	Part	Description	Qty.
201*	183171	PLUG	1
202	193032	NUT, packing	1
203**	193124	V-PACKING, throat, V-Max, UHMWPE, blue	4
204**	15C989	GLAND, packing, male, throat	1
205	243347	CYLINDER, pump	1
	196754	Model 248205, 277070	
	196754	Model 249057, 249059, 257146	
206		BALL, 0.375 in.	1
	101947*	Model 248205, 249057, 277070, 257146	
	116327*	Model 249059, ceramic	
207**	156633	PACKING, o-ring	1
208**	193125	V-PACKING, piston, V-MAX, UHMWPE, blue	4
210	240150	VALVE, piston	1
212*	244199	KIT, seat, carbide (includes 214, 227)	1
	244571	Model 248205, 249057, 277070, 257146	
213		HOUSING, intake (foot)	1
	15C783	Model 248205	
	196753	Model 249059, 249057	
	195894	Model 277070, 257146	
214		BALL	1
	102972* †	Model 248205, 249057, 277070, 257146, 0.875 in.	
	111453*	Model 249059, ceramic, 0.750 in.	
215		GUIDE, ball	1
	196967	Model 249059, 249057	
	193027	Model 248205, 277070, 257146	
216**	118504	WIPER, piston	1
217**	183185	GLAND, female, piston	1
218**	15E329	V-PACKING, leather, piston	3
219**	183178	GLAND, packing, male	1
220	248210	SLEEVE, cylinder	1
	257031	Model 248205, 249057, 249059, 277070	
221**	107098	PACKING, o-ring	2
222	248207	ROD, piston	1
	249028	Model 248205, 277070	
	249028	Model 249059, 249057, 257146	
223**	183175	V-PACKING, leather, throat	3
224**	15C990	GLAND, female, throat	1
227* †*	108526	PACKING, o-ring	1
228**	C20987	SPACER, nut	1
229**	15C998	WASHER, backup	1
230**	118494	O-RING, fluoroelastomer (not used on 249057, 249059, 257146)	1
231	117608	NIPPLE, straight	1
		Model 249057, 249059 (not shown)	
232	162485	ADAPTER, 3/8 npt x 3/8 npsm	1
		Model 249057, 249059, 257146 (not shown)	

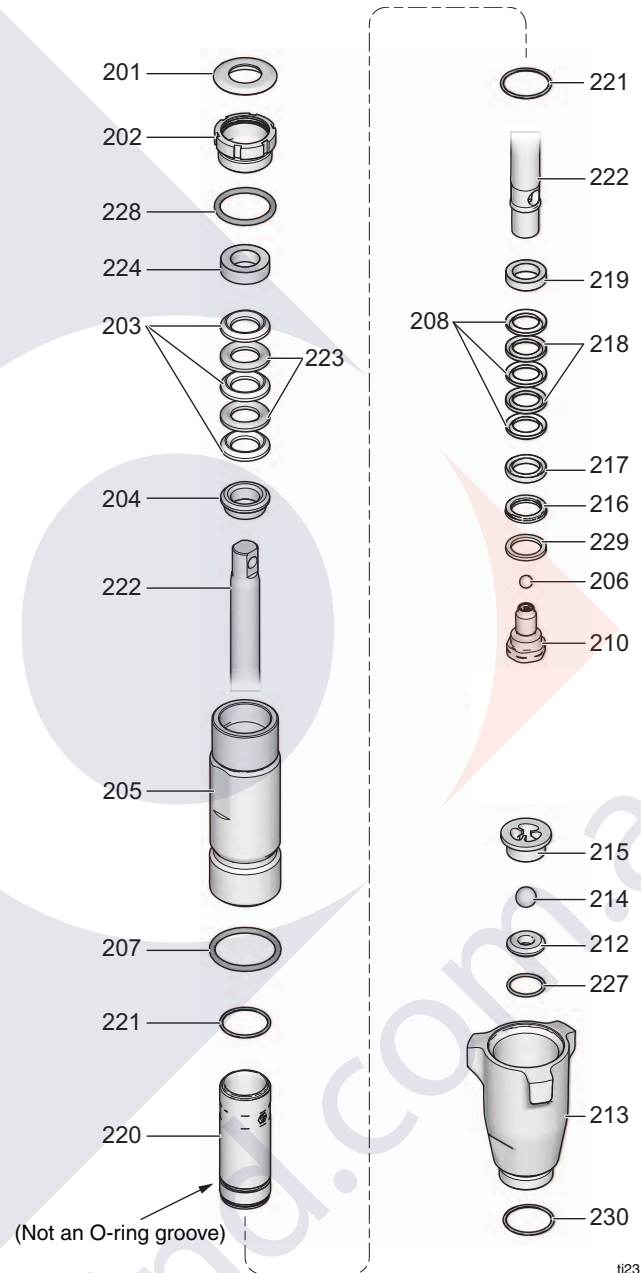

* These parts are also included in Repair Kit 248213, which may be purchased separately.

† These parts are also included in Carbide Seat Kit 244199, which may be purchased separately.

** These parts are also included in Pump Repair Kit 249189, which may be purchased separately.

ti23114e

Parts - Pump 253056

Ref.	Part	Description	Qty.
201*	179810	SEAL, throat	1
202	193046	NUT, packing	1
203*	192692	V-PACKING, throat, V-Max, UHMWPE, blue	3
204*	15C987	GLAND, male, throat	1
205	287876	CYLINDER, pump	1
206*		BALL, check	1
	105444*	BALL, sst, 0.3125 in. (optional)	
	119259*	BALL, ceramic, 0.3125 in. (standard)	
207*	156593	PACKING, o-ring	1
208*	192693	V-PACKING, piston, V-MAX, UHMWPE, blue	3
210	287877	VALVE, piston	1
212† ^		SEAT, carbide, (not sold separately)	1
213	287878	HOUSING, intake	1
214		BALL, check, inlet	1
	102972* †	BALL, sst, 0.875 in. (optional)	
	111453* ^	BALL, ceramic, 0.750 (standard)	
215	196967	GUIDE, ball	1
216*	118503	WIPER, piston	1
217*	178969	GLAND, female, piston	1
218*	178939	V-PACKING, leather, piston	2
219*	196880	GLAND, male	1
220	248209	SLEEVE, cylinder	1
221*	108526	O-RING, ptfе	2
222	249969	ROD, piston (Mark IV)	1
223*	178940	V-PACKING, leather, throat	2
224*	15C988	GLAND, female	1
227* † ^	108526	PACKING, o-ring	1
228*	158776	SPACER, throat, nut	1
229*	15C997	WASHER, backup	1
230	15G494	SPACER, sleeve	1
231*	107098	O-RING	1

* These parts are also included in Repair Kit with stainless steel ball, 287825, which may be purchased separately.
 * These parts are also included in Repair Kit with ceramic ball, 24V063, which may be purchased separately.
 † These parts are also included in Carbide Seat Kit with stainless steel ball, 244199, which may be purchased separately.
 ^ These parts are also included in Carbide Seat Kit with ceramic ball, 24V071, which may be purchased separately.

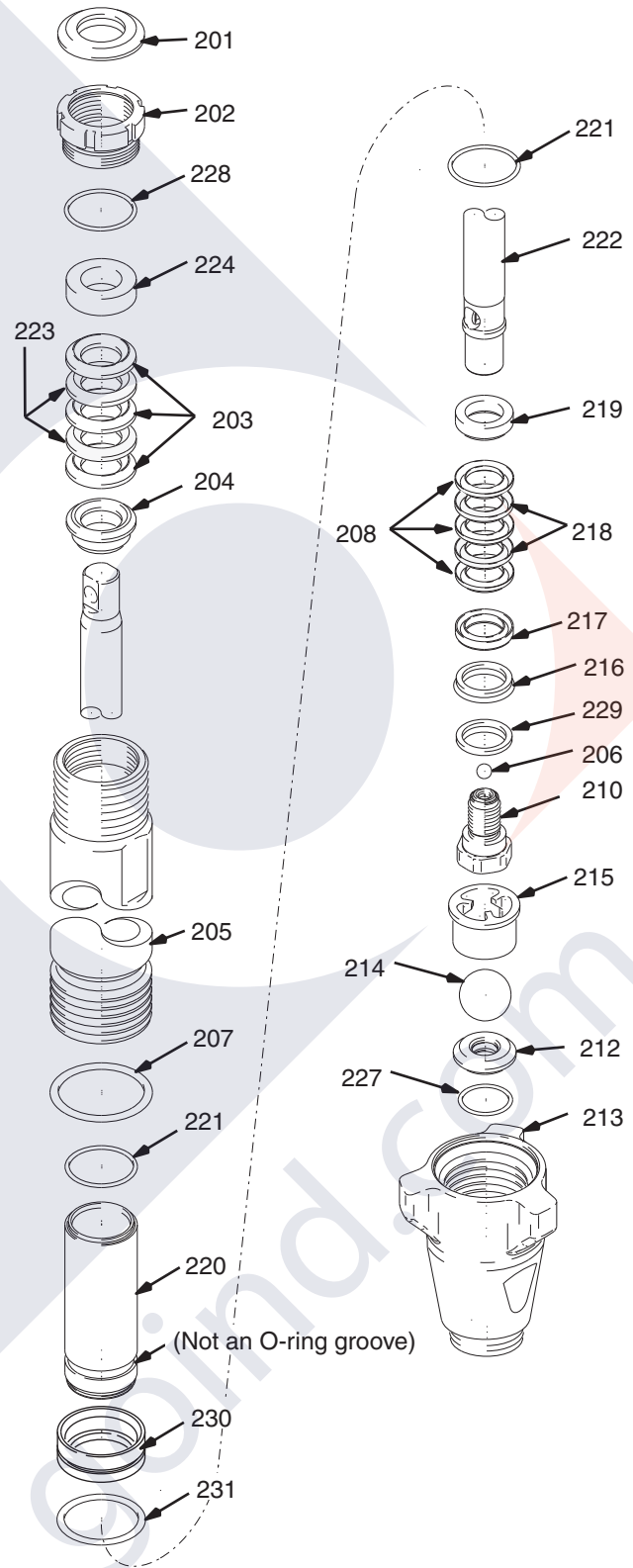

Technical Data

	U.S.	Metric
Maximum Working Pressure	3300 psi	227 bar, 22.7 MPa
Fluid Inlet Size	1-5/16-12 un(m)	1-5/16-12 un(m)
Fluid Outlet Size		
248204, 255968, 277069		1/4 npt(f)
248205, 249057, 249059, 253056, 277070, 257146		3/8 npt(f)
Wetted Parts	stainless steel, PTFE, leather, nylon, zinc-plated carbon steel, tungsten carbide, chrome plating, fluoroelastomer, acetal, polyethylene	

Graco Standard Warranty

Graco warrants all equipment referenced in this document which is manufactured by Graco and bearing its name to be free from defects in material and workmanship on the date of sale to the original purchaser for use. With the exception of any special, extended, or limited warranty published by Graco, Graco will, for a period of twelve months from the date of sale, repair or replace any part of the equipment determined by Graco to be defective. This warranty applies only when the equipment is installed, operated and maintained in accordance with Graco's written recommendations.

This warranty does not cover, and Graco shall not be liable for general wear and tear, or any malfunction, damage or wear caused by faulty installation, misapplication, abrasion, corrosion, inadequate or improper maintenance, negligence, accident, tampering, or substitution of non-Graco component parts. Nor shall Graco be liable for malfunction, damage or wear caused by the incompatibility of Graco equipment with structures, accessories, equipment or materials not supplied by Graco, or the improper design, manufacture, installation, operation or maintenance of structures, accessories, equipment or materials not supplied by Graco.

This warranty is conditioned upon the prepaid return of the equipment claimed to be defective to an authorized Graco distributor for verification of the claimed defect. If the claimed defect is verified, Graco will repair or replace free of charge any defective parts. The equipment will be returned to the original purchaser transportation prepaid. If inspection of the equipment does not disclose any defect in material or workmanship, repairs will be made at a reasonable charge, which charges may include the costs of parts, labor, and transportation.

THIS WARRANTY IS EXCLUSIVE, AND IS IN LIEU OF ANY OTHER WARRANTIES, EXPRESS OR IMPLIED, INCLUDING BUT NOT LIMITED TO WARRANTY OF MERCHANTABILITY OR WARRANTY OF FITNESS FOR A PARTICULAR PURPOSE.

Graco's sole obligation and buyer's sole remedy for any breach of warranty shall be as set forth above. The buyer agrees that no other remedy (including, but not limited to, incidental or consequential damages for lost profits, lost sales, injury to person or property, or any other incidental or consequential loss) shall be available. Any action for breach of warranty must be brought within two (2) years of the date of sale.

GRACO MAKES NO WARRANTY, AND DISCLAIMS ALL IMPLIED WARRANTIES OF MERCHANTABILITY AND FITNESS FOR A PARTICULAR PURPOSE, IN CONNECTION WITH ACCESSORIES, EQUIPMENT, MATERIALS OR COMPONENTS SOLD BUT NOT MANUFACTURED BY GRACO. These items sold, but not manufactured by Graco (such as electric motors, switches, hose, etc.), are subject to the warranty, if any, of their manufacturer. Graco will provide purchaser with reasonable assistance in making any claim for breach of these warranties.

In no event will Graco be liable for indirect, incidental, special or consequential damages resulting from Graco supplying equipment hereunder, or the furnishing, performance, or use of any products or other goods sold hereto, whether due to a breach of contract, breach of warranty, the negligence of Graco, or otherwise.

FOR GRACO CANADA CUSTOMERS

The Parties acknowledge that they have required that the present document, as well as all documents, notices and legal proceedings entered into, given or instituted pursuant hereto or relating directly or indirectly hereto, be drawn up in English. Les parties reconnaissent avoir convenu que la rédaction du présente document sera en Anglais, ainsi que tous documents, avis et procédures judiciaires exécutés, donnés ou intentés, à la suite de ou en rapport, directement ou indirectement, avec les procédures concernées.

Graco Information

For the latest information about Graco products, visit www.graco.com.

For patent information, see www.graco.com/patents.

TO PLACE AN ORDER, contact your Graco distributor or call 1-800-690-2894 to identify the nearest distributor.

*All written and visual data contained in this document reflects the latest product information available at the time of publication.
Graco reserves the right to make changes at any time without notice.*

Original instructions. This manual contains English. MM 310643

Graco Headquarters: Minneapolis
International Offices: Belgium, China, Japan, Korea

GRACO INC. AND SUBSIDIARIES • P.O. BOX 1441 • MINNEAPOLIS MN 55440-1441 • USA

Copyright 2014, Graco Inc. All Graco manufacturing locations are registered to ISO 9001.

www.graco.com
Revised W, May 2019