

# Instructions—Parts List



## 1:1 RATIO Fast-Flo<sup>®</sup> Pump

307427ZAC  
EN

Air-operated piston transfer pump for low viscosity fluids. For professional use only.

Only models that are EX certified are approved for use in European explosive atmosphere locations (see page 4).

1.2 MPa, 12.4 bar (180 psi) Maximum Air Input Pressure  
1.2 MPa, 12.4 bar (180 psi) Maximum Fluid Working Pressure

For models that are  certified, see page 4.



### Important Safety Instructions

Read all warnings and instructions in this manual.  
Save these instructions.  
Refer to page 4 for a list of pump models.



**Intertek**

This symbol on the nameplate means the product is listed by ETL.  
(UL Standard No. 79, Standard for Power-Operated Pumps for Petroleum Product Dispensing Systems).

## Table of Contents

Symbols .....	2
Warnings .....	2
Pump Models .....	4
Installation .....	5
Operation .....	8
Maintenance .....	9
Troubleshooting .....	10
Pump Service .....	11
Pump Parts .....	12
Displacement Pump Service .....	17
Displacement Pump Parts .....	18
Accessories .....	35
Dimensions .....	37
Technical Data .....	38
Warranty .....	40
Graco Information .....	40

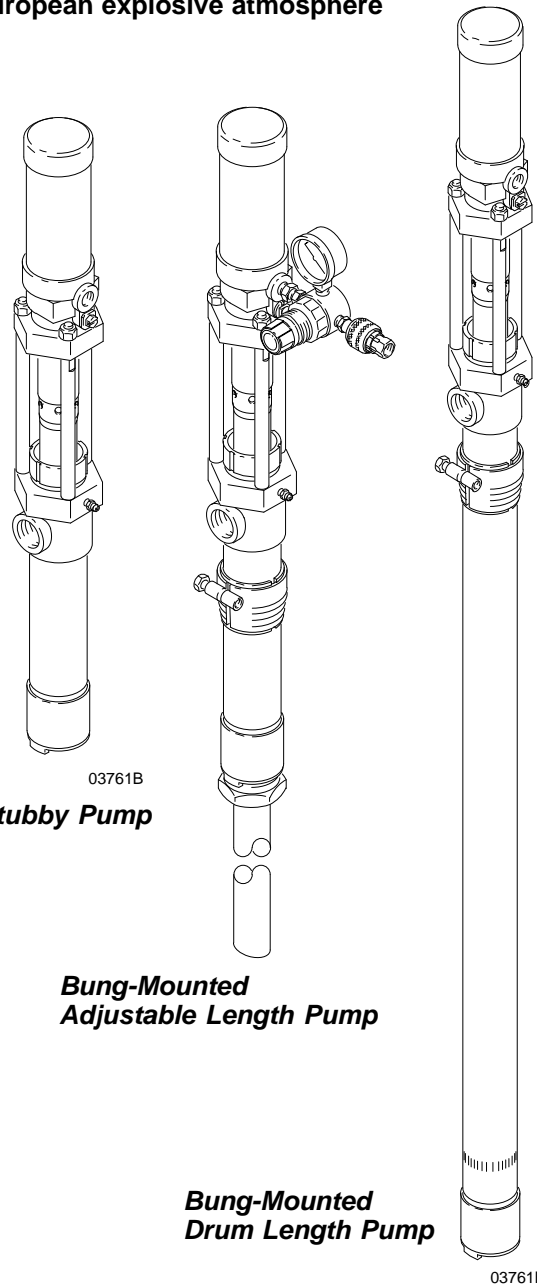

# Symbols

## Warning Symbol



This symbol alerts you to the possibility of serious injury or death if you do not follow the instructions.

## Caution Symbol



This symbol alerts you to the possibility of damage to or destruction of equipment if you do not follow the instructions.

## ! WARNING



INSTRUCTIONS

### EQUIPMENT MISUSE HAZARD

Equipment misuse can cause the equipment to rupture or malfunction and result in serious injury.

- This equipment is for professional use only.
- Read all instruction manuals, tags, and labels before operating the equipment.
- Use the equipment only for its intended purpose. If you are uncertain about usage, call your Graco distributor.
- Do not alter or modify this equipment. Use only genuine Graco parts and accessories.
- Check equipment daily. Repair or replace worn or damaged parts immediately.
- Do not exceed the maximum working pressure stated on the equipment or in the **Technical Data** for your equipment. Do not exceed the maximum working pressure of the lowest rated component in your system.
- Use fluids and solvents which are compatible with the equipment wetted parts. Refer to the **Technical Data** section of all equipment manuals. Read the fluid and solvent manufacturer's warnings.
- Securely mount the pump. Do not attempt to operate it while holding it.
- Do not use hoses to pull equipment.
- Route hoses away from traffic areas, sharp edges, moving parts, and hot surfaces. Do not expose Graco hoses to temperatures above 82°C (180°F) or below -40°C (-40°F).
- Wear hearing protection when operating this equipment.
- Do not lift pressurized equipment.
- Comply with all applicable local, state, and national fire, electrical, and safety regulations.

# WARNING



## FIRE AND EXPLOSION HAZARD

Improper grounding, poor ventilation, open flames or sparks can cause a hazardous condition and result in a fire or explosion and serious injury.

- Ground the equipment and the object being sprayed. Refer to **Grounding the System** on page 5.
- If there is any static sparking or you feel an electric shock while using this equipment, **stop spraying/dispensing immediately**. Do not use the equipment until you identify and correct the problem.
- Provide fresh air ventilation to avoid the buildup of flammable fumes from solvents or the fluid being sprayed/dispensed.
- Keep the spray/dispense area free of debris, including solvent, rags, and gasoline.
- Electrically disconnect all equipment in the spray/dispense area.
- Extinguish all open flames or pilot lights in the spray/dispense area.
- Do not smoke in the spray/dispense area.
- Do not turn on or off any light switch in the spray/dispense area while operating or if fumes are present.
- Do not operate a gasoline engine in the spray/dispense area.



## TOXIC FLUID HAZARD

Hazardous fluid or toxic fumes can cause serious injury or death if splashed in the eyes or on the skin, inhaled, or swallowed.

- Know the specific hazards of the fluid you are using.
- Store hazardous fluid in an approved container. Dispose of hazardous fluid according to all local, state and national guidelines.
- Any additives to the air supply, such as oil or anti-freeze will be exhausted into the atmosphere.
- Always wear protective eyewear, gloves, clothing and respirator as recommended by the fluid and solvent manufacturer.



## MOVING PARTS HAZARD

Moving parts can pinch or amputate your fingers.

- Keep clear of all moving parts when starting or operating the pump.
- Before servicing the equipment, follow the **Pressure Relief Procedure** on page 8 to prevent the equipment from starting unexpectedly.

# Pump Models

## ETL LISTED PUMPS

The following pumps are ETL listed for light viscosity paints, lacquers, varnishes, thinners, solvents when installed in accordance with NFPA (National Fire Protection Association) Standards No. 30, Flammable and Combustible Liquids Code, and No. 33 Spray Finishing Using Flammable Materials. The ETL listed pumps have been evaluated using ASTM Reference Fuels A, C, H, I, and IRM No. 3 Oil and that any fluid used in these pumps should be reviewed against these fluids to determine suitability. The carbon steel pumps are for non-corrosive fluids, and the stainless steel pumps are for corrosives.

### Stubby Pumps

Model No.	Displacement Pump No.	Description	Parts Pages
<b>**226943 Series B</b>	215956 Series C	Carbon Steel, Leather Packings	14, 18
<b>*226944 Series B</b>	215957 Series C	Carbon Steel, Polyethylene Packings	14, 19
<b>*226945 Series B</b>	215958 Series B	Stainless Steel, Polyethylene Packings	15, 28

### Bung-Mounted Drum Length Pumps

Model No.	Displacement Pump No.	Description	Parts Pages
<b>**226940 Series B</b>	215953 Series D	Carbon Steel, Leather Packings	12, 18
<b>**226941 Series B</b>	215954 Series D	Carbon Steel, Polyethylene Packings	12, 19
<b>**226942 Series B</b>	215955 Series B	Stainless Steel, Polyethylene Packings	13, 27
<b>686445 Series A ‡</b>	215954 Series D	Carbon Steel, Polyethylene Packings	12, 19

‡ Model 686445 includes a spout, part no. 206265.

\*This model is  II 2 G T6 certified.

\*\*This model is  II 1/2 G T6 ITS03ATEX11227 certified.

4 307427

## NON-LISTED PUMPS

These pumps are for non-corrosive light viscosity fluids such as anti-freeze, windshield washer solvent, ATF, motor oil, and hydraulic oil.

### Stubby Pumps

Model No.	Displacement Pump No.	Description	Parts Pages
<b>226948 Series B</b>	218114 Series A	Carbon Steel, Rubber Packings	14, 24
<b>226952 Series B</b>	220439 Series A	Stainless Steel, Rubber Packings	15, 34

### Bung-Mounted Drum Length Pumps

Model No.	Displacement Pump No.	Description	Parts Pages
<b>226947 Series B</b>	218113 Series A	Carbon Steel, Rubber Packings	12, 24
<b>226951† Series B</b>	218116 Series A	Carbon Steel, Rubber Packings	16, 25
<b>226953 Series B</b>	220440 Series A	Stainless Steel, Rubber Packings	13, 33

† Model 226951 has a suction tube that can be extended 457 mm (18 in.). Non-extended pump length is 724 mm (28.5 in.). Fully extended pump length is 1180 mm (46.4 in.).

## NON-LISTED PUMPS

These pumps are for general fluid transfer applications.

### Stubby Pumps

Model No.	Displacement Pump No.	Description	Parts Pages
<b>*237130 Series A</b>	237254 Series A	Carbon Steel, Leather Packings	14, 20
<b>*237131 Series A</b>	237255 Series A	Carbon Steel, PTFE Packings	14, 22
<b>*237132 Series A</b>	237256 Series A	Stainless Steel, PTFE Packings	15, 31

### Bung-Mounted Drum Length Pumps



Model No.	Displacement Pump No.	Description	Parts Pages
<b>**237133 Series A</b>	215953 Series D	Carbon Steel, Leather Packings	12, 18
<b>**237134 Series A</b>	237449 Series A	Carbon Steel, PTFE Packings	12, 21
<b>**237129 Series A</b>	237253 Series A	Stainless Steel, PTFE Packings	13, 30

# Installation

## General Information

- The Typical Installation shown in Fig. 2 is only a guide for selecting and installing system components. Contact your Graco distributor for assistance in planning a system to suit your needs.
- Always use Genuine Graco Parts and Accessories.
- Reference numbers and letters in parentheses refer to the callouts in the figures and the parts lists on pages 12–34.
- For ETL listed pumps. All pipe joints are to be made tight with ETL listed gasoline-resistant pipe compound.

## Grounding the System

 <b>WARNING</b>	
	<b>FIRE AND EXPLOSION HAZARD</b>
	This pump must be grounded. Before operating the pump, ground the system as explained below. Also read the section <b>FIRE AND EXPLOSION HAZARD</b> on page 3.

To reduce the risk of static sparking, ground the pump and all other equipment used or located in the pumping area. Check your local electrical code for detailed grounding instructions for your area and type of equipment. **Ground all of this equipment.**

1. *ETL-Listed Pumps:* Use a ground wire, connector, and clamp. See Fig. 1. Loosen screw (X). Insert one exposed end of a 12 ga (1.5 mm<sup>2</sup>) minimum ground wire (Y) through the eye of the ground terminal connector (W) and tighten screw (X) securely. Connect the other end of the wire to a true earth ground. Order Part No. 237569 Ground Wire and Clamp.

2. *Non ETL-Listed Pumps:* See Fig. 1. Remove the ground screw (Z). Fasten the ground connector (W) onto the pump with the ground screw (Z) and tighten securely. Loosen screw (X). Insert one exposed end of a 12 ga (1.5 mm<sup>2</sup>) minimum ground wire (Y) through the eye of the ground terminal connector (W) and tighten screw (X) securely. Connect the other end of the wire to a true earth ground. Order Part No. 222011 Ground Connector/Wire and Clamp.

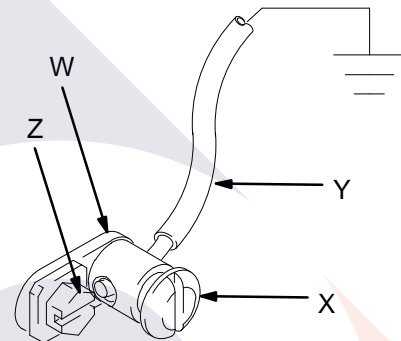
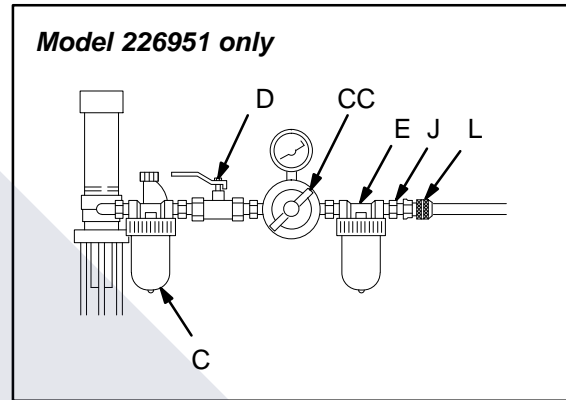
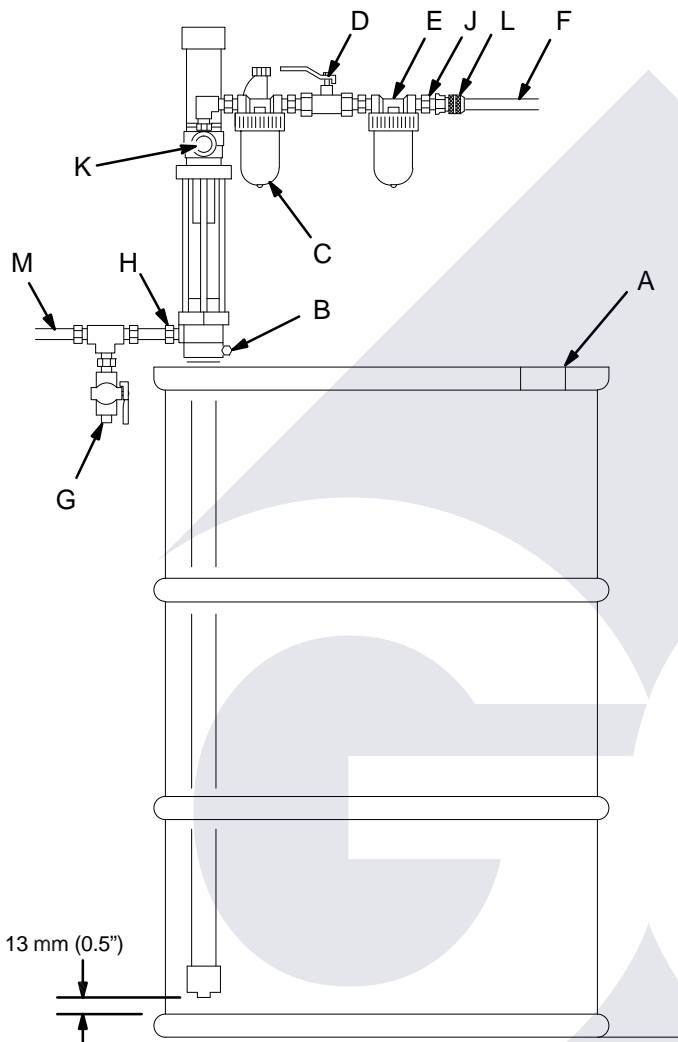

Fig. 1

TI1052

3. *Air and fluid hoses:* use only electrically conductive hoses.
4. *Air compressor:* according to manufacturer's recommendations.
5. *Dispensing valve:* grounding is obtained through connection to a properly grounded fluid hose and pump.
6. *Fluid supply container:* according to local code.
7. *Object being sprayed:* according to local code.
8. *All solvent pails used when flushing,* according to local code. Use only metal pails, which are conductive. Do not place the pail on a non-conductive surface, such as paper or cardboard, which interrupts the grounding continuity.

# Installation



## KEY

- A Vent Plug
- B Bung Adapter
- C Air Line Lubricator
- D Bleed-type Master Air Valve
- E Air Line Filter
- F Grounded Air Hose
- G Fluid Drain Valve
- H Fluid Outlet
- J Pin Fitting
- K Air Control Valve  
(All Models except 226951)
- L Air Line Coupler
- M Grounded Fluid Hose
- CC Air Regulator Kit  
(Model 226951 only)

Fig. 2

03762

## Mounting the Pump

Always rigidly mount the pump to suit the type of installation planned. Graco mounting accessories are shown in the **Accessories** section. With 200 liter (55 gallon) drum length pumps, screw the bung adapter (B) tightly into the bung hole of the drum and adjust to hold the pump 13 mm (0.5 in.) off the bottom of the drum. Loosen the vent plug (A) to prevent formation of a vacuum in the drum. Stubby pumps may be mounted on a wall or on the side of a drum with a clamp. Drum pumps can also be mounted to the side of a drum.

**NOTE:** Refer to **Dimensions** on page 37 for pump dimensions, and air inlet and fluid outlet sizes.

# Installation

## System Accessories

Refer to Fig. 2 and the Accessories section.

**NOTE:** To ensure maximum pump performance, be sure that all accessories used are properly sized to meet your system's requirements.

Most models are supplied with a needle-type air control valve (K) at the pump air inlet. Model 226951 is equipped with an air regulator kit (CC) instead (see Fig. 3). All models are supplied with an air line quick disconnect coupler (L) to connect the air line to the pump and accessories.

## ⚠ WARNING

A bleed-type master air valve (D) and a fluid drain valve (G) are required in your system, to help reduce the risk of serious injury, including splashing fluid in the eyes or on the skin, and injury from moving parts if you are adjusting or repairing the pump.

The *bleed-type master air valve* (D) relieves air trapped between this valve and the pump after the pump is shut off. Trapped air can cause the pump to cycle unexpectedly and result in serious injury, including amputation. Locate the valve close to the pump.

The *fluid drain valve* (G) helps relieve pressure in the displacement pump, hose, and dispensing valve when shutting off the pump. Actuating the dispensing valve to relieve pressure may not be sufficient, especially if there is a clog in the hose or the dispensing valve.

For automatic air motor lubrication, install an air line lubricator (C) downstream from the air regulator (if supplied) and all other accessories. Install a bleed-type master air valve (D) close to the pump. Next, install the air regulator (CC), if supplied. Install an air line filter (E) upstream from all other accessories, to remove harmful dirt and moisture from the compressed air supply.

Using a suitable adapter, install the male disconnect pin fitting (J) in the air filter inlet. Install the air line quick disconnect coupler (L) on the air hose (F), but do not connect it to the pin fitting yet.

Connect an electrically conductive fluid hose (M) to the 3/4 npt(f) fluid outlet.

## Model 226951 Only

Using moderate force, extend the pump suction tube, insert the pump into the drum or tank bung hole, and screw the bung adapter (B) tightly into the bung hole. Lift the pump about 13 mm (0.5 in.) and tighten the bung adapter (B) screw to hold the pump. Loosen the vent plug (A). Refer to Fig. 2.

## ⚠ CAUTION

To prevent damaging the o-ring seals inside the suction tube, do not use excessive force when extending the suction tube.

## All Other Models

Refer to Fig. 2 and to the mounting accessories shown on page 35 for pump mounting methods.

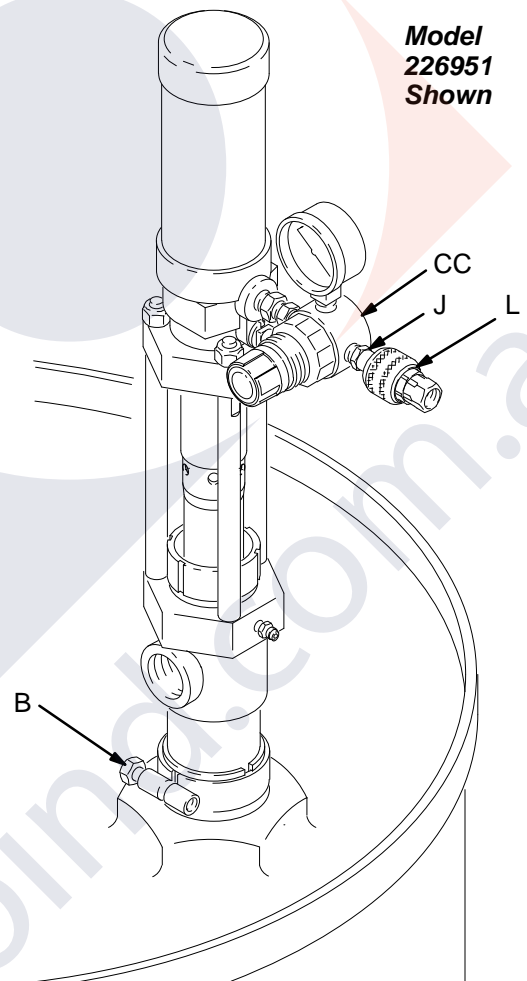

Fig. 3

03763

# Operation

## Pressure Relief Procedure

### **⚠ WARNING**

#### **PRESSURIZED EQUIPMENT HAZARD**

The system pressure must be manually relieved to prevent the system from starting or spraying accidentally. To reduce the risk of an injury from accidental spray from the gun, splashing fluid, or moving parts, follow the **Pressure Relief Procedure** whenever you:

- are instructed to relieve the pressure,
- stop spraying,
- check or service any of the system equipment,
- or install or clean the spray nozzle.

1. Shut off the air to the pump.
2. Close the bleed-type master air valve (required in your system).
3. Hold a metal part of the dispensing valve firmly to the side of a grounded metal pail, and trigger the valve to relieve pressure.
4. Open the fluid drain valve (required in your system) to relieve all fluid pressure, having a container ready to catch the drainage.
5. Leave the drain valve open until you are ready to dispense again.

*If you suspect that the nozzle or hose is completely clogged, or that pressure has not been fully relieved after following the steps above, **very slowly** loosen the hose end coupling and relieve pressure gradually, then loosen completely. Now clear the nozzle or hose.*

## Flush the Pump Before Using

The pump was tested in lightweight oil, which was left in to protect pump parts. To prevent contamination of the fluid you are pumping, flush the pump with a compatible solvent before using it.

To flush the pump, connect a short hose to the pump outlet, insert the pump intake into a pail of compatible solvent, direct the hose into a pail, and start the pump as explained at right.

Cycle the pump slowly for at least 5 minutes, then stop and disconnect the air hose. Push up on the ball of the intake valve (N) to drain the lower part of the pump. See Fig. 4. Turn the pump over to drain the upper part of the pump.

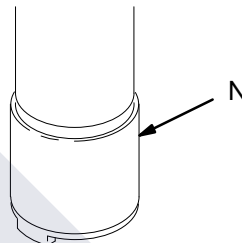

Fig. 4

03765

## Starting and Adjusting the Pump

With the air valve (K) or regulator (CC) closed, turn on the air supply and connect the air line coupler (L). See Figs. 3 or 5. Make sure all dispensing valves are open.

Slowly open the air valve (K) or regulator (CC) until the pump cycles 5 to 20 cycles per minute. The pump itself only takes a few strokes to prime. In a large system, however, the pump may have to be cycled for several minutes to fill all the lines. Once the entire system is primed, use the air valve or regulator to control pump speed and cycle rate; always use the lowest pressure necessary to get the desired results.

When used for transfer and supply operations with no dispensing valve, the pump will run whenever air is supplied.

## Pump Shutdown

### **⚠ WARNING**

To reduce the risk of serious injury whenever you are instructed to relieve pressure, always follow the **Pressure Relief Procedure** at left.

1. Disconnect the air line coupler (L).
2. Relieve the pressure.



# Maintenance

Fill the wet-cup (P) 1/2 full of Graco Throat Seal Liquid (TSL) or compatible solvent and keep it 1/2 full to keep fluid from drying on the displacement rod and damaging pump throat packings. See Fig. 5.

Lubricate the throat packings frequently when you are pumping a non-lubricating fluid, or are shutting down for more than a few days. Some pumps have a grease fitting (DD) for this purpose. See Fig. 5.

The accessory air line lubricator (C) provides automatic air motor lubrication. To manually lubricate the motor, disconnect the air line at the air motor inlet, put about 15 drops of lightweight oil in the inlet, reconnect the air line and turn on the air to blow oil into the motor.

Never allow the pump to run dry of fluid being pumped. A dry pump will quickly accelerate to a high speed, possibly damaging itself. If your pump accelerates quickly, or is running too fast, stop it immediately and check the fluid supply. If the supply container is empty and air has been pumped into the lines, prime the pump and lines with fluid, or flush and leave filled with compatible solvent. Be sure to eliminate all air from the fluid system.

## ⚠ WARNING

To reduce the risk of serious injury whenever you are instructed to relieve pressure, always follow the **Pressure Relief Procedure** on page 8.

## ⚠ WARNING

Do not attempt to adjust the packing nut with the pump operating.

Periodically, check the tightness of the packing nut (P). Relieve the pressure, then tighten enough to prevent leakage; no tighter. See Fig. 5. If the leakage can not be stopped, change the packings to prevent exposure to the fluid being pumped.

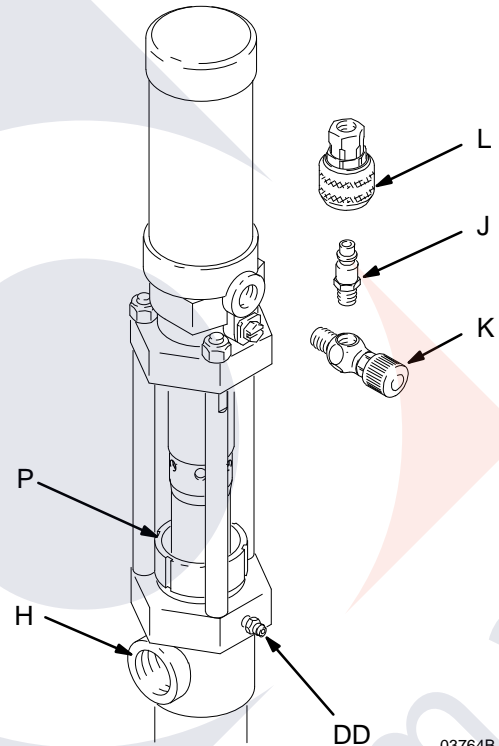

Fig. 5

03764B

# Troubleshooting

## **⚠ WARNING**

To reduce the risk of serious injury whenever you are instructed to relieve pressure, always follow the **Pressure Relief Procedure** on page 8.

1. Relieve the pressure.
2. Check all other possible remedies before disassembling the pump.

PROBLEM	CAUSE	SOLUTION
The pump fails to operate.	Dirty or worn air motor.	Clean, service; see the separate motor manual 307456.
	Inadequate air supply or restricted lines.	Clean lines or increase the air supply (see Technical Data).
	Closed or clogged air valves.	Open or clear the valves.
	Clogged fluid hose or valve.	Clear the hose or valves.
	Worn or damaged valves or seals.	Service the valves or seals.
The pump operates, but the output is low on both strokes.	Clogged fluid hose or valve.	Clear the hose or valves.
	Exhausted fluid supply.	Refill the fluid supply and reprime the pump.
	Worn or damaged valves or seals.	Service the valves or seals.
The pump operates, but the output is low on the downstroke.	Held open or worn intake valve.	Clear or service the valve.
	Worn or damaged valves or seals.	Service the valves or seals.
The pump operates, but the output is low on the upstroke.	Held open or worn piston valve.	Clear or service the valve.
	Worn or damaged valves or seals.	Service the valves or seals.
Erratic or accelerated operation.	Exhausted fluid supply.	Refill the fluid supply and reprime the pump.
	Broken air motor compression spring.	Replace the spring.

# Pump Service

## Disconnecting the Air Motor

### **⚠ WARNING**

To reduce the risk of serious injury whenever you are instructed to relieve pressure, always follow the **Pressure Relief Procedure** on page 8.

1. Flush the pump.
2. Relieve the pressure. Remove the pump from its mounting.
3. See Fig. 6. Unscrew the tie rod locknuts (103).
4. Unscrew and remove the screw (105) and barrel (104).
5. Raise the air motor (115) away from the displacement pump (114). Unscrew the displacement rod (15) from the air motor connecting rod (S).
6. To order pump parts, refer to the parts lists on pages 12–16. Refer to pages 17–34 for displacement pump service and parts information. Refer to manual 307456 for air motor service and parts information.

## Reconnecting the Air Motor

1. When reconnecting the air motor, use lithium base grease on the threads of the displacement rod (15). Make sure the o-ring (14) is in place on the rod.
2. Insert the muffler (T) into the air motor connecting rod (S) as shown in Fig. 6.
3. Tighten the displacement rod (15) into the air motor connecting rod hand tight, and install the barrel and screw set (104 and 105).
4. Apply thread sealant to the threads of the tie rods (106). To ensure proper alignment, first thread the tie rod locknuts (106) loosely onto the tie rods, then torque evenly to 15 N•m (8 ft–lb).

**NOTE:** Removing the muffler (T) will increase both pump flow rate and exhaust noise.

5. Reconnect the groundwire if it was disconnected during service.

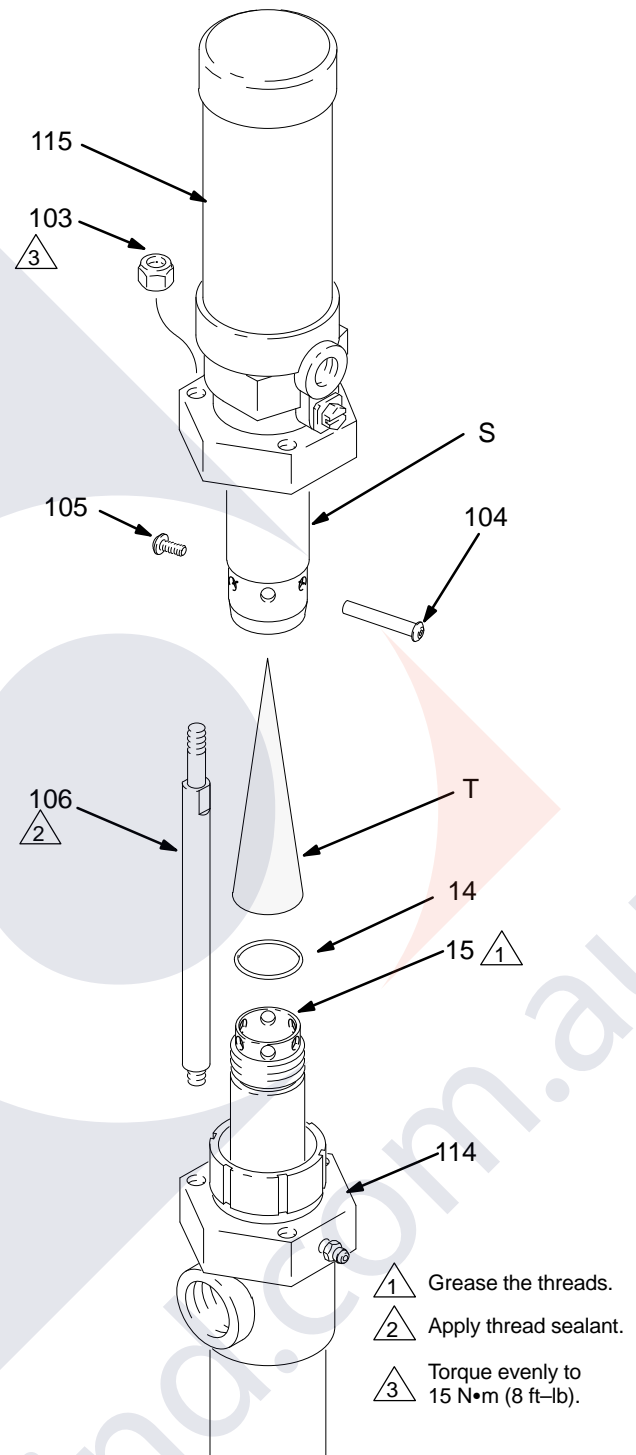

**Fig. 6**

03766B

# Pump Parts

## Bung Mount Drum-Length Pumps, Carbon Steel Models

**Model 226940, Series B,** leather packed  
**Model 226941, Series B,** polyethylene packed  
**Model 226947, Series B,** rubber packed  
**Model 237133, Series A,** leather packed  
**Model 237134, Series A,** PTFE packed  
**Model 686445, Series A,** polyethylene packed, with spout

Ref. No.	Part No.	Description	Qty.
103	104541	NUT, lock; M8; w/nylon insert	3
104 ✓	15B249	PIN, barrel	1
105 ✓	15B250	SCREW	1
106	177171	TIE ROD	3
107	190165	FITTING, air line; for Models 237133 and 237134 only	1
	169969	FITTING, air line for all other models	1
108	206264	NEEDLE VALVE ASSY Includes items 109–112, 116, 117	1
109 ✓	157628	. PACKING, o-ring; nitrile rubber	1
110	165722	. BODY	1
111	166531	. RING, friction washer	1
112	166529	. NEEDLE	1
113	190164	COUPLER, air line; for Models 237133 and 237134 only	1
	114558	COUPLER, air line for all other models	1
114	215953	DISPLACEMENT PUMP, for Models 226940 and 237133; see page 18	1
	215954	DISPLACEMENT PUMP for Model 226941; see page 19	1
	237449	DISPLACEMENT PUMP for Model 237134; see page 21	1
	218113	DISPLACEMENT PUMP for Model 226947; see page 24	1
115	223099	AIR MOTOR KIT See instruction manual 307456	1
116	166532	NUT, packing	1
117	164698	KNOB, adjusting	1
118	206265	SPOUT; Model 686445 only (not shown)	1

### Model 226940 Shown

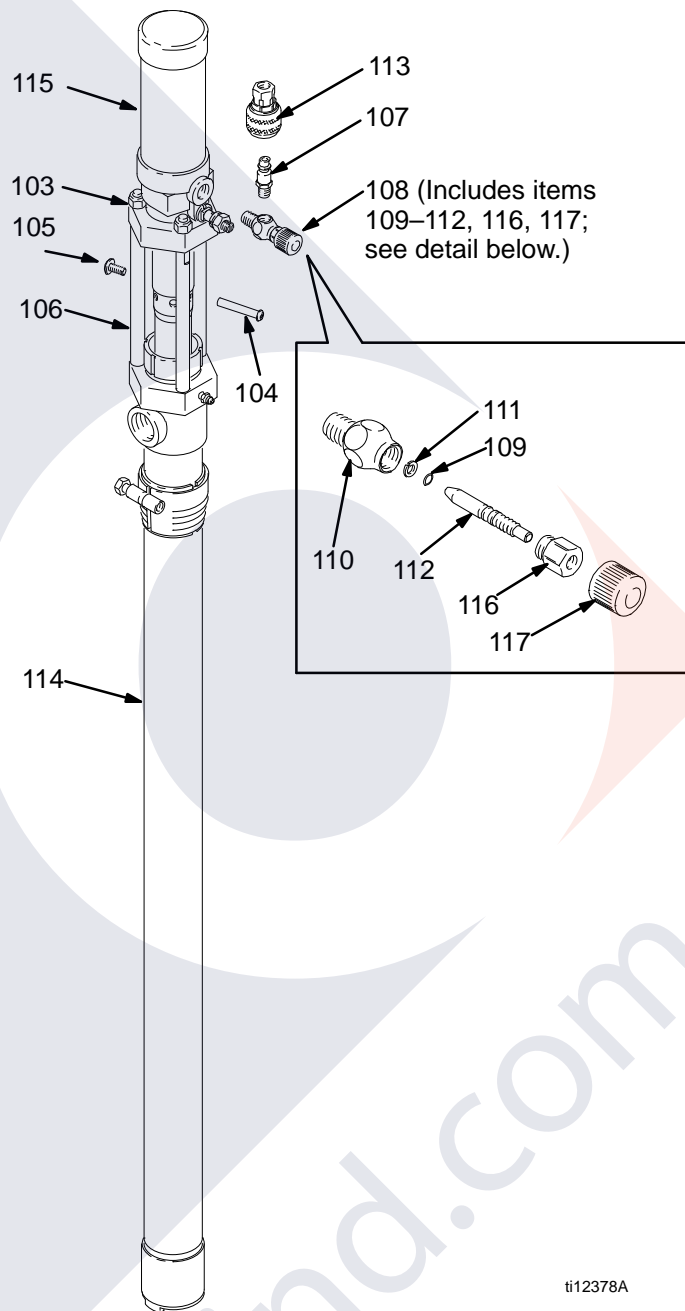

ti12378A

✓ Keep these spare parts on hand to reduce down time.

# Pump Parts

## Bung Mount Drum-Length Pumps, Stainless Steel Models

**Model 226942, Series B**, polyethylene packed  
**Model 226953, Series B**, rubber packed  
**Model 237129, Series A**, PTFE packed

**Model 226953 Shown**

Ref. No.	Part No.	Description	Qty.
102	215961	MOUNTING KIT for Stainless Steel Pumps; includes items 103, 113, 116, 117	1
103	104541	. NUT, lock; M8; w/nylon insert	3
104	15B249	. PIN, barrel	1
105	15B250	. SCREW	1
106	177170	. TIE ROD	3
107	190165	. FITTING, air line for Model 237129 only	1
	169969	. FITTING, air line for all other models	1
108	206264	. NEEDLE VALVE ASSY Includes items 109–112, 116, 117	1
109	157628	. . PACKING, o-ring; nitrile rubber	1
110	165722	. . BODY	1
111	166531	. . RING, friction washer	1
112	166529	. . NEEDLE	1
113	190164	. COUPLER, air line; For Model 237129 only	1
	114558	. COUPLER, air line for all other models	1
114	215955	DISPLACEMENT PUMP For Model 226942; see page 27	1
	220440	DISPLACEMENT PUMP For Model 226953; see page 33	1
	237253	DISPLACEMENT PUMP For Model 237129; see page 30	1
115	223099	AIR MOTOR KIT See instruction manual 307456	1
116	166532	NUT, packing	1
117	164698	KNOB, adjusting	1

✓ *Keep these spare parts on hand to reduce down time.*

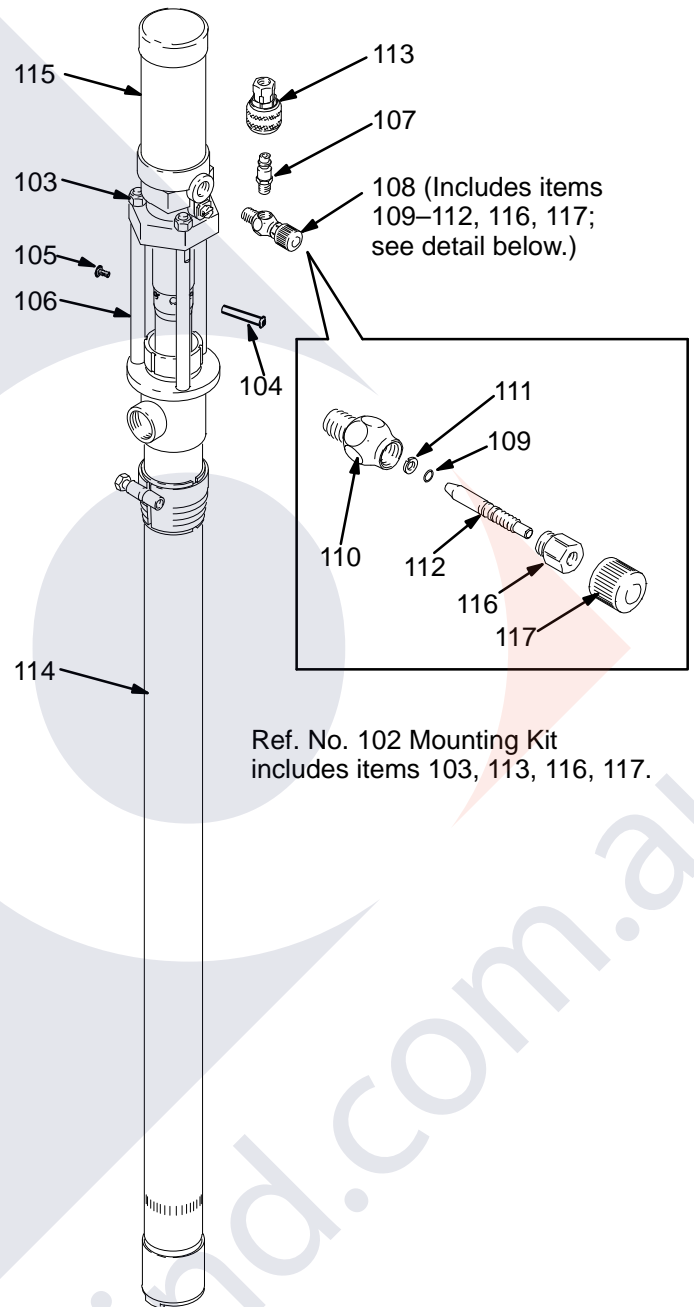

Ref. No. 102 Mounting Kit  
includes items 103, 113, 116, 117.

03772B

# Pump Parts

## Stubby Length Pumps, Carbon Steel Models

**Model 226943, Series B,** leather packed  
**Model 226944, Series B,** polyethylene packed  
**Model 226948, Series B,** rubber packed  
**Model 237130, Series A,** leather packed  
**Model 237131, Series A,** PTFE packed

**Model 226943 Shown**

Ref. No.	Part No.	Description	Qty.
103	104541	NUT, lock; M8; w/nylon insert	3
104 ✓	15B249	PIN, barrel	1
105 ✓	15B250	SCREW	1
106	177171	TIE ROD	3
107	190165	FITTING, air line; For Models 237130 and 237131 only	1
	169969	FITTING, air line for all other models	1
108	206264	NEEDLE VALVE ASSY Includes items 109–112, 116, 117	1
109 ✓	157628	. PACKING, o-ring; nitrile rubber	1
110	165722	. BODY	1
111	166531	. RING, friction washer	1
112	166529	. NEEDLE	1
113	190164	COUPLER, air line; For Models 237130 and 237131 only	1
	114558	COUPLER, air line for all other models	1
114	215956	DISPLACEMENT PUMP For Model 226943; see page 18	1
	215957	DISPLACEMENT PUMP For Model 226944; see page 19	1
	218114	DISPLACEMENT PUMP For Model 226948; see page 24	1
	237254	DISPLACEMENT PUMP For Model 237130; see page 20	1
	237255	DISPLACEMENT PUMP For Model 237131; see page 22	1
115	223099	AIR MOTOR KIT See instruction manual 307456	1
116	166532	NUT, packing	1
117	164698	KNOB, adjusting	1

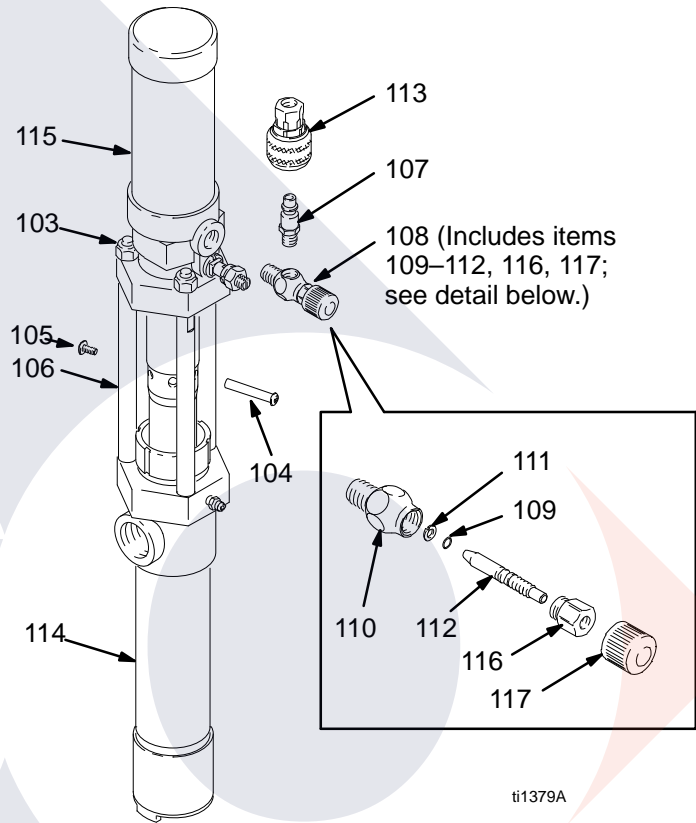

✓ Keep these spare parts on hand to reduce down time.

# Pump Parts

## Stubby Length Pumps, Stainless Steel Models

**Model 226945, Series B**, polyethylene packed  
**Model 226952, Series B**, rubber packed  
**Model 237132, Series A**, PTFE packed

**Model 226945 Shown**

Ref. No.	Part No.	Description	Qty.
102	215961	MOUNTING KIT for Stainless Steel Pumps; includes items 103–113, 116, 117	1
103	104541	. NUT, lock; M8; w/nylon insert	3
104	15B249	PIN, barrel	1
105	15B250	SCREW	1
106	177170	. TIE ROD	3
107	190165	FITTING, air line for Model 237132 only	1
	169969	. FITTING, air line for all other models	1
108	206264	. NEEDLE VALVE ASSY Includes items 109–112, 116, 117	1
109	157628	. . PACKING, o-ring; nitrile rubber	1
110	165722	. . BODY	1
111	166531	. . RING, friction washer	1
112	166529	. . NEEDLE	1
113	190164	COUPLER, air line; For Model 237132 only	1
	114558	. COUPLER, air line for all other models	1
114	215958	DISPLACEMENT PUMP For Model 226945; see page 28	1
	220439	DISPLACEMENT PUMP For Model 226952; see page 34	1
	237256	DISPLACEMENT PUMP For Model 237132; see page 31	1
115	223099	AIR MOTOR KIT See instruction manual 307456	1
116	166532	NUT, packing	1
117	164698	KNOB, adjusting	1

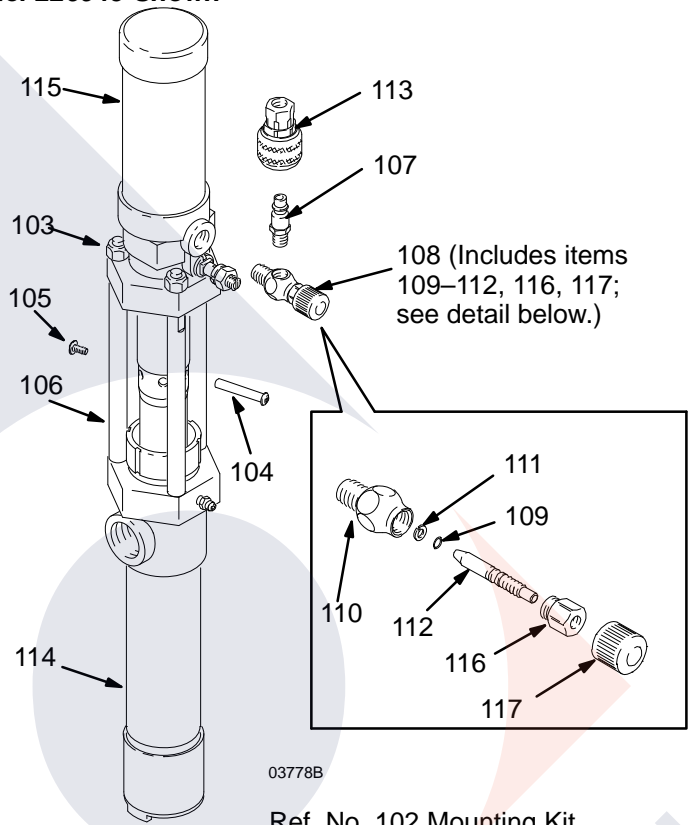

Ref. No. 102 Mounting Kit  
includes items 103, 113, 116, 117.

✓ *Keep these spare parts on hand to reduce down time.*

goind.com.au

# Pump Parts

## Bung Mount Adjustable Length Pump, Carbon Steel Model

Fits bung type containers from 724 mm (28.5 in.) to 1180 mm (46.4 in.) deep  
(maximum 456 mm [18 in.] adjustment).

Model 226951, Series B, rubber packed

Ref.

No.	Part No.	Description	Qty.
103	104541	NUT, lock; M8; w/nylon insert	3
104	15B249	PIN, barrel	1
105	15B250	SCREW	1
106	177171	TIE ROD	3
107	169969	FITTING, air line	1
113	114558	COUPLER, air line	1
114	218116	DISPLACEMENT PUMP for Model 226951; see page 25	1
115	223099	AIR MOTOR KIT See instruction manual 307456	1
118	218316	AIR REGULATOR KIT Includes items 107, 113, 119-123	1
119	100403	PLUG, pipe; 1/8 npt	1
120	104655	GAUGE, air pressure; 0-60 psi (0-0.4 MPa, 0-4.2 bar); 1/8 npt inlet	1
121	104815	REGULATOR, air; 0-60 psi (0-0.4 MPa, 0-4.2 bar); see 308167	1
122	103656	NIPPLE, pipe; 1/8 npt	1
123	100030	BUSHING, pipe; 1/4 npt(m) x 1/8 npt(f)	1

✓ Keep these spare parts on hand to reduce down time.

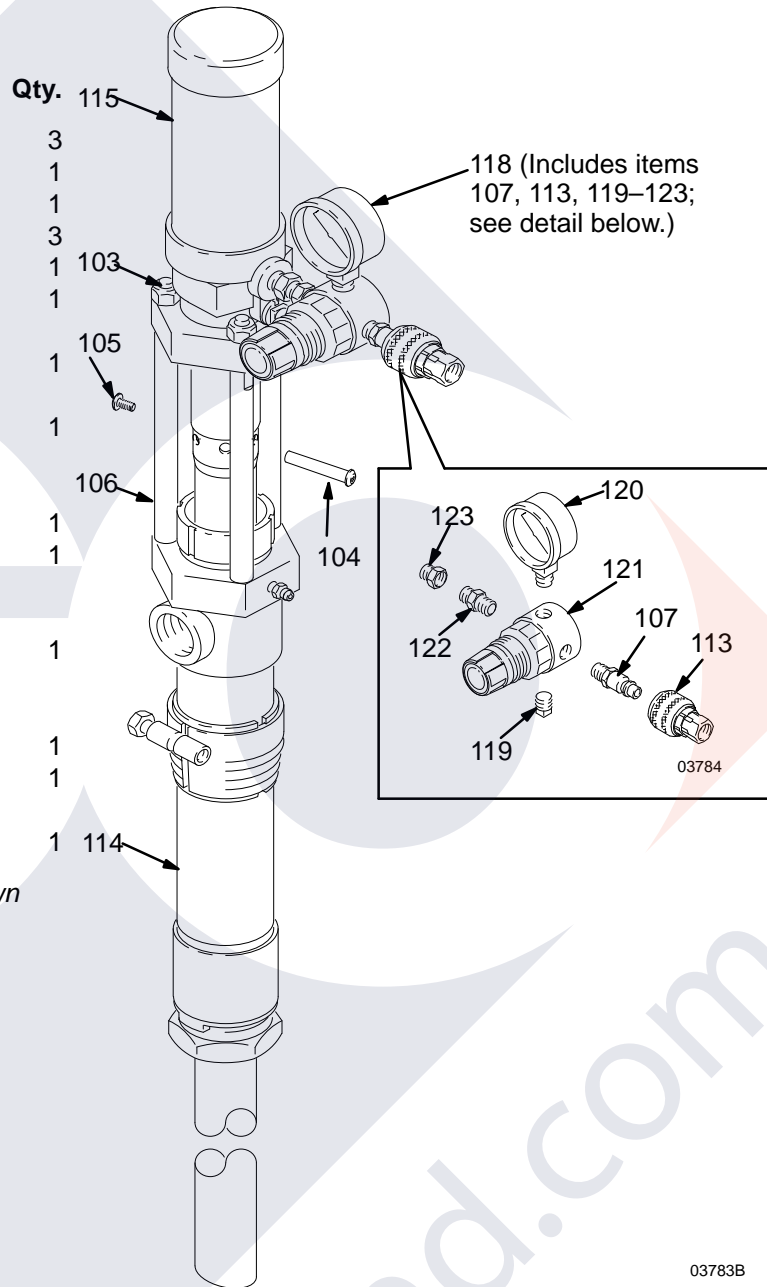

03783B



# Displacement Pump Service

## CARBON STEEL DISPLACEMENT PUMPS, with leather, polyethylene, or PTFE packings

This procedure covers the following displacement pumps. Refer to the parts drawings on the indicated pages for an illustration of your pump.

- Model 215953, page 18.
- Model 215956, page 18.
- Model 215954, page 19.
- Model 215957, page 19.
- Model 237254, page 20.
- Model 237449, page 21.
- Model 237255, page 22.

### Before You Start

1. Disconnect the displacement pump from the air motor as explained on page 11.
2. Be sure you have all the necessary repair parts on hand to reduce downtime.
3. Repair Kits are available. For best results, use all the new parts in the kit even if the old parts look good. Refer to the parts drawing for your pump.

### Intake Valve

1. Unscrew the intake valve housing (23) from the cylinder (13), using a strap wrench. Disassemble the valve and clean and inspect all parts.

**NOTE:** On Models 237254 and 237255, inspect the ball (28) and seat in the housing (23) for wear or nicks.

2. Replace parts as necessary. Reassemble as shown in the applicable parts drawing.

### Piston Valve

1. Using a strap wrench, grip the cylinder (13) near the outlet housing (6) and unscrew it from the housing. Pull the cylinder down off the piston. Check the inner surface of the cylinder for scoring or wear by running a finger over the surface or holding the part up to the light at an angle.
2. Loosen the lower nut (16) and unscrew the valve housing (18) from the connecting rod (17). Unscrew the piston stud (22).

3. Clean and inspect all piston parts. Replace parts as necessary. Reassemble the piston parts as shown, *being sure that the lips of the u-cup packing (21) are facing up*. Screw the piston stud (22) into the valve housing (18) and torque to 31 N•m (23 ft–lb).
4. When reassembling the piston to the connecting rod (17), screw the connecting rod all the way into the displacement rod (15). Tighten the upper nut (16) against the displacement rod and torque to 33 N•m (24 ft–lb). Adjust the lower nut (16) to allow 3.1 mm (0.125 in.) free travel for the disk (19).

### Throat Packings

1. Remove the cylinder (13) and piston as explained previously. Remove the packing nut (1) and pull the displacement rod (15) out of the top of the outlet housing (6). Inspect the outer surface of the displacement rod for scoring or wear by running a finger over the surface or holding it up to the light at an angle.
  2. Remove the throat packings from the outlet housing (6).
  3. Clean and inspect the parts for wear or damage. Lubricate the packings before reassembly. Install the parts one at a time, in the same position as before. *The lips of the v-packings must face down against fluid pressure.*
- NOTE:** On displacement pumps 215953, 215956, and 237254, install the two leather v-packings (4) below the single PTFE v-packing (3).
4. Leave the packing nut (1) loose until the displacement rod (15) has been installed.

### CAUTION

Insert the displacement rod from the top of the outlet housing to prevent shearing of the packings.

5. Tighten the packing nut just enough to prevent leaking. Overtightening can damage the packings.
6. Reconnect the displacement pump to the air motor as explained on page 11.

# Displacement Pump Parts

**Model 215953 Displacement Pump, Series D**  
200 Liter (55 Gallon) Size, Carbon Steel, Leather Packed

**Model 215956 Displacement Pump, Series C**  
Stubby Size, Carbon Steel, Leather Packed

Ref. No.	Part No.	Description	Qty.
1	177152	NUT, packing	1
2*	178543	GLAND, female; stainless steel	1
3*	172487	V-PACKING; PTFE	1
4*	172384	V-PACKING; leather	2
5*	172385	GLAND, male; stainless steel	1
6	178542	HOUSING, outlet	1
7	101281	FITTING, grease	1
8	104537	O-RING; PTFE	2
9	214583	BUNG ADAPTER ASSY Includes items 10 and 12 (used on Model 215953 only)	1
10	172405	. BUSHING; nylon	1
12	222308	. ADAPTER, bung; carbon steel	1
13	172416	CYLINDER (Model 215953)	1
	177165	CYLINDER (Model 215956)	1
14	177156	O-RING; fluoroelastomer	1
15	217189	ROD, displacement	1
16	105775	NUT, hex; M14 x 1.5	2
17	177150	ROD, connecting (Model 215953)	1
	177160	ROD, connecting (Model 215956)	1
18	177168	HOUSING, valve, piston	1
19	177155	VALVE, piston	1
20	172393	WASHER; stainless steel	1
21*	172392	CUP, piston; leather	1
22	177151	PISTON, pump	1
23	217102	VALVE, intake	1

\* These parts are included in Repair Kit 213012, which may be purchased separately.

## Model 215953 Shown

- △1 Torque to 31 N•m (23 ft-lb).
- △2 Torque to 33 N•m (24 ft-lb).
- △3 Lips of v-packings must face down.
- △4 Lips of packing must face up.
- △5 Used on Model 215953 only.

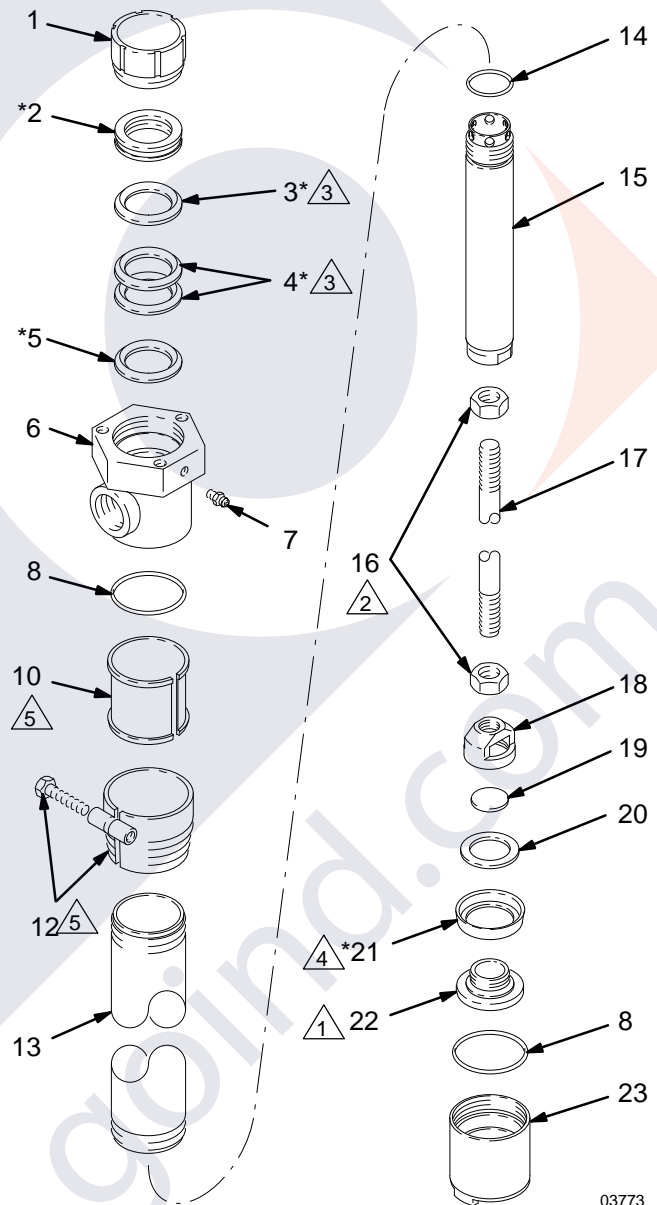

03773

# Displacement Pump Parts

## Model 215954 Displacement Pump, Series D

200 Liter (55 Gallon) Size, Carbon Steel, Polyethylene Packed

## Model 215957 Displacement Pump, Series C

Stubby Size, Carbon Steel, Polyethylene Packed

Ref. No.	Part No.	Description	Qty.
1	177152	NUT, packing	1
2*	178543	GLAND, female; stainless steel	1
3*	177164	V-PACKING; polyethylene	3
5*	172385	GLAND, male; stainless steel	1
6	178542	HOUSING, outlet	1
7	101281	FITTING, grease	1
8	104537	O-RING; PTFE	2
9	214583	BUNG ADAPTER ASSY Includes items 10 and 12 (used on Model 215954 only)	1
10	172405	. BUSHING; nylon	1
12	222308	. ADAPTER, bung; carbon steel	1
13	172416	CYLINDER (Model 215954)	1
	177165	CYLINDER (Model 215957)	1
14	177156	O-RING; fluoroelastomer	1
15	217189	ROD, displacement	1
16	105775	NUT, hex; M14 x 1.5	2
17	177150	ROD, connecting (Model 215954)	1
	177160	ROD, connecting (Model 215957)	1
18	177168	HOUSING, valve, piston	1
19	177155	VALVE, piston	1
20	172393	WASHER; stainless steel	1
21*	177159	CUP, piston; polyethylene	1
22	177151	PISTON, pump	1
23	217102	VALVE, intake	1

\* These parts are included in Repair Kit 215964, which may be purchased separately.

### Model 215954 Shown

- △1 Torque to 31 N•m (23 ft-lb).
- △2 Torque to 33 N•m (24 ft-lb).
- △3 Lips of v-packings must face down.
- △4 Lips of packing must face up.
- △5 Used on Model 215954 only.

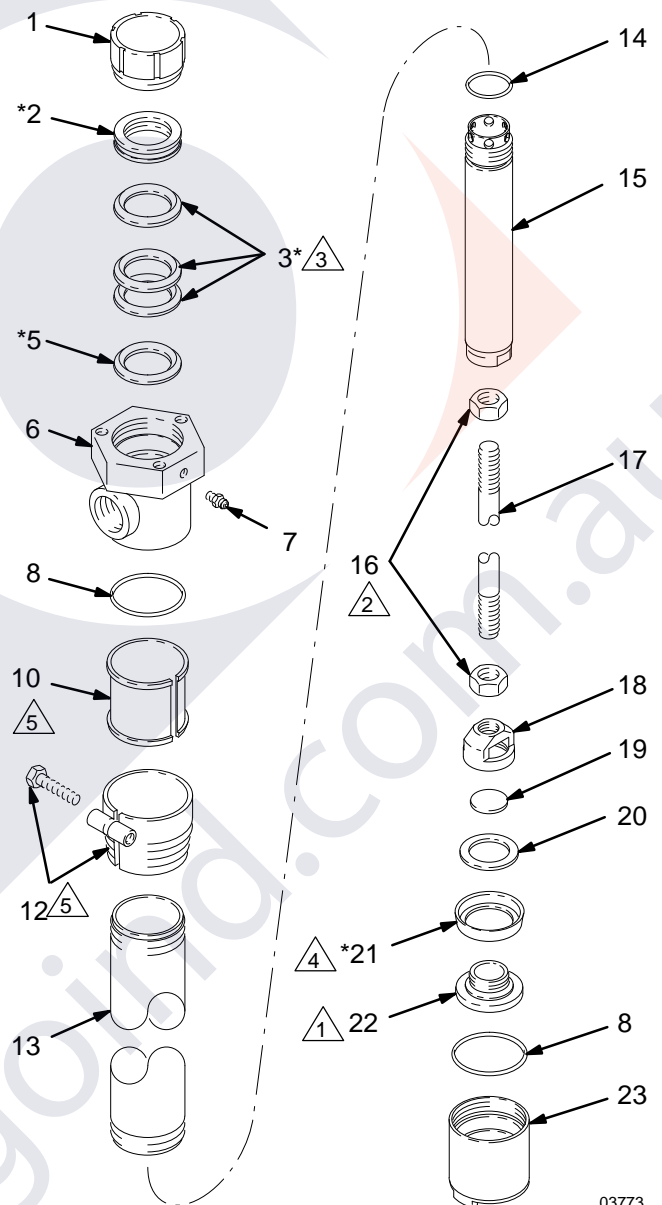

03773

# Displacement Pump Parts

## Model 237254 Displacement Pump, Series A Stubby Size, Carbon Steel, Leather Packed

Ref. No.	Part No.	Description	Qty.
1	177152	NUT, packing	1
2*	178543	GLAND, female; stainless steel	1
3*	172487	V-PACKING; PTFE	1
4*	172384	V-PACKING; leather	2
5*	172385	GLAND, male; stainless steel	1
6	178542	HOUSING, outlet	1
7	101281	FITTING, grease	1
8	104537	O-RING; PTFE	1
13	190063	CYLINDER	1
14	177156	O-RING; fluoroelastomer	1
15	217189	ROD, displacement	1
16	105775	NUT, hex; M14 x 1.5	2
17	177160	ROD, connecting	1
18	177168	HOUSING, valve, piston	1
19	177155	VALVE, piston	1
20	172393	WASHER; stainless steel	1
21*	172392	CUP, piston; leather	1
22	177151	PISTON, pump	1
23	237493	VALVE, intake	1
26	172399	PIN, ball stop	1
27	177230	GUIDE, ball	1
28	104586	BALL, intake; 32 mm dia.	1

\* These parts are included in Repair Kit 213012, which may be purchased separately.

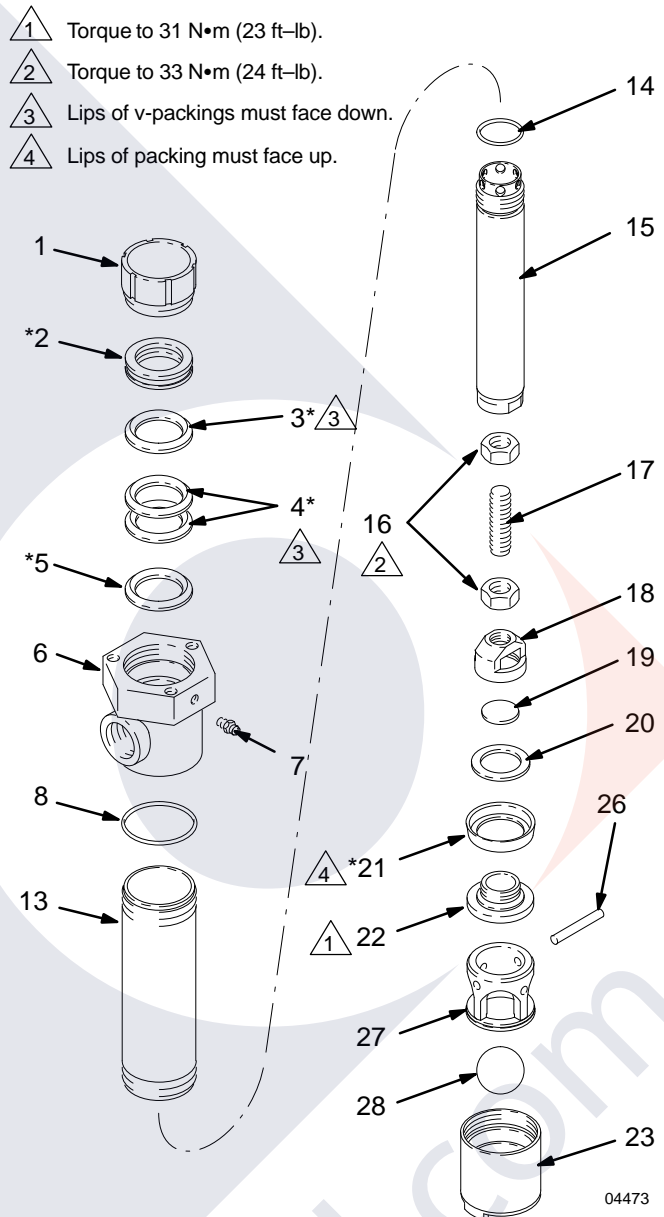

04473

# Displacement Pump Parts

## Model 237449 Displacement Pump, Series A

200 Liter (55 Gallon) Size, Carbon Steel, PTFE Packed

Ref. No.	Part No.	Description	Qty.
1	177152	NUT, packing	1
2*	178543	GLAND, female; stainless steel	1
3*	172487	V-PACKING; PTFE	3
5*	172385	GLAND, male; stainless steel	1
6	178542	HOUSING, outlet	1
7	101281	FITTING, grease	1
8	104537	O-RING; PTFE	2
9	214583	BUNG ADAPTER ASSY Includes items 10 and 12	1
10	172405	. BUSHING; nylon	1
12	222308	. ADAPTER, bung; carbon steel	1
13	172416	CYLINDER	1
14	177156	O-RING; fluoroelastomer	1
15	217189	ROD, displacement	1
16	105775	NUT, hex; M14 x 1.5	2
17	177150	ROD, connecting	1
18	177168	HOUSING, valve, piston	1
19	177155	VALVE, piston	1
20	172393	WASHER; stainless steel	1
21*	172489	CUP, piston; PTFE	1
22	177151	PISTON, pump	1
23	217102	VALVE, intake	1

\* These parts are included in Repair Kit 213013, which may be purchased separately.

- 1 Torque to 31 N•m (23 ft-lb).
- 2 Torque to 33 N•m (24 ft-lb).
- 3 Lips of v-packings must face down.
- 4 Lips of packing must face up.

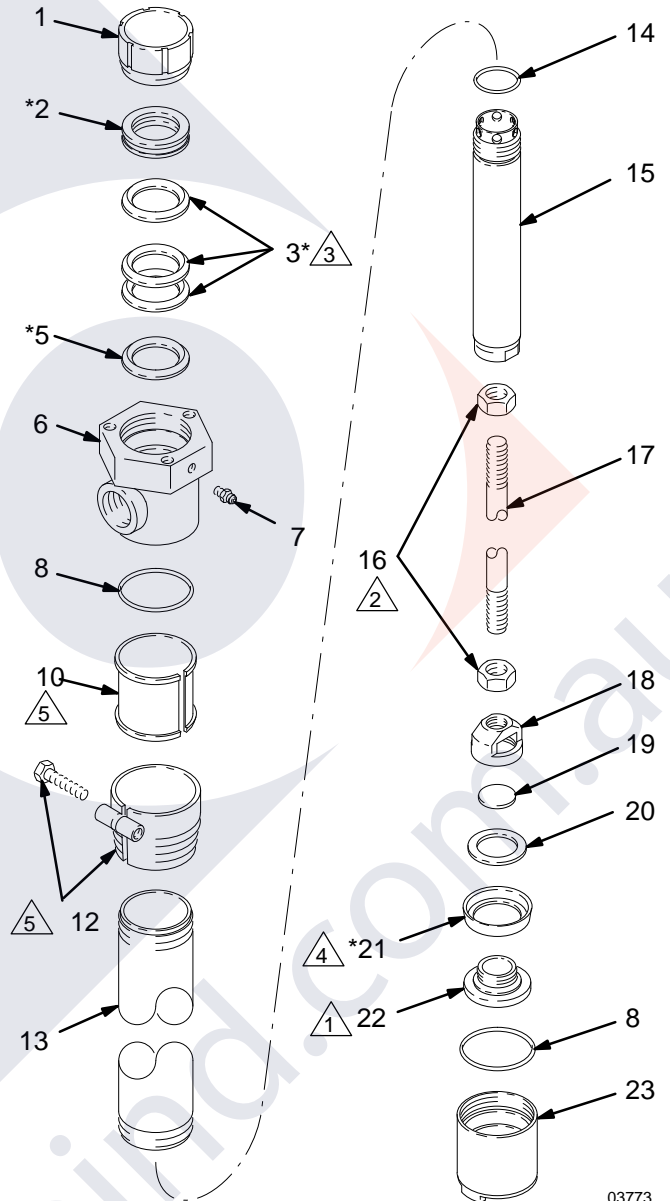

03773

# Displacement Pump Parts

## Model 237255 Displacement Pump, Series A Stubby Size, Carbon Steel, PTFE Packed

Ref. No.	Part No.	Description	Qty.
1	177152	NUT, packing	1
2*	178543	GLAND, female; stainless steel	1
3*	172487	V-PACKING; PTFE	3
5*	172385	GLAND, male; stainless steel	1
6	178542	HOUSING, outlet	1
7	101281	FITTING, grease	1
8	104537	O-RING; PTFE	1
13	190063	CYLINDER	1
14	177156	O-RING; fluoroelastomer	1
15	217189	ROD, displacement	1
16	105775	NUT, hex; M14 x 1.5	2
17	177160	ROD, connecting	1
18	177168	HOUSING, valve, piston	1
19	177155	VALVE, piston	1
20	172393	WASHER; stainless steel	1
21*	172489	CUP, piston; PTFE	1
22	177151	PISTON, pump	1
23	237493	VALVE, intake	1
26	172399	PIN, ball stop	1
27	177230	GUIDE, ball	1
28	104586	BALL, intake; 32 mm dia.	1

\* These parts are included in Repair Kit 213013, which may be purchased separately.

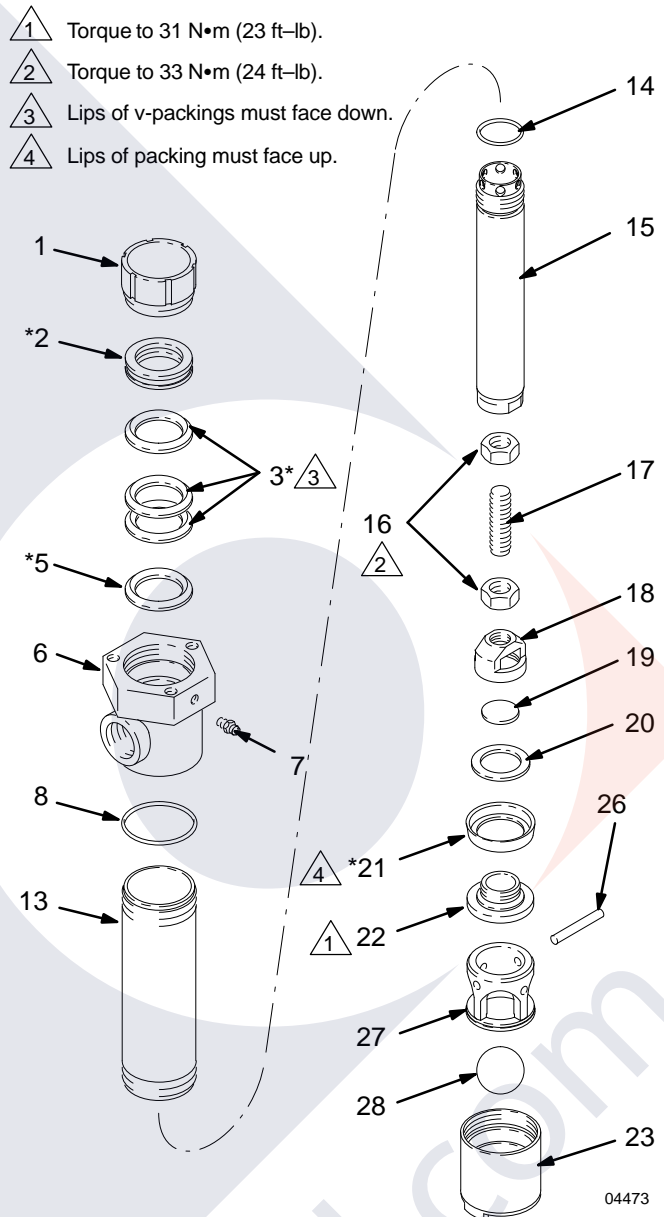

04473

# Displacement Pump Service

## CARBON STEEL DISPLACEMENT PUMPS, with rubber packings

This procedure covers the following displacement pumps. Refer to the parts drawings on the indicated pages for an illustration of your pump.

- Model 218113, page 24.
- Model 218114, page 24.
- Model 218116, page 25.

### Before You Start

1. Disconnect the displacement pump from the air motor as explained on page 11.
2. Be sure you have all the necessary repair parts on hand to reduce downtime.
3. Repair Kit 218112 is available. For best results, use all the new parts in the kit even if the old parts look good.

### Intake Valve

1. Unscrew the intake valve housing (23) from the cylinder (13), using a strap wrench. Disassemble the valve and clean and inspect all parts.
2. Replace parts as necessary. Reassemble as shown in the applicable parts drawing.

### Piston Valve

1. Using a strap wrench, grip the cylinder (13) near the outlet housing (6) and unscrew it from the housing. Pull the cylinder down off the piston. Check the inner surface of the cylinder for scoring or wear by running a finger over the surface or holding the part up to the light at an angle.
2. Loosen the lower nut (16) and unscrew the valve housing (18) from the connecting rod (17). Unscrew the piston stud (22).

3. Clean and inspect all piston parts. Replace parts as necessary. Reassemble the piston parts as shown, *being sure that the lips of the u-cup packing (21) are facing up*. Screw the piston stud (22) into the valve housing (18) and torque to 31 N•m (24 ft–lb).
4. When reassembling the piston to the connecting rod (17), screw the connecting rod all the way into the displacement rod (15). Tighten the upper nut (16) against the displacement rod and torque to 33 N•m (24 ft–lb). Adjust the lower nut (16) to allow 3.1 mm (0.125 in.) free travel for the disk (19).

### Throat Packings

1. Remove the cylinder (13) and piston as explained previously. Remove the packing nut (1) and pull the displacement rod (15) out of the top of the outlet housing (6). Inspect the outer surface of the displacement rod for scoring or wear by running a finger over the surface or holding it up to the light at an angle.
2. Remove the throat packings from the outlet housing (6).
3. Clean and inspect the parts for wear or damage. Lubricate the packings before reassembly. Install the parts one at a time, in the same position as before. *The lips of the u-cup must face down against fluid pressure.*
4. Leave the packing nut (1) loose until the displacement rod (15) has been installed.

### CAUTION

Insert the displacement rod from the top of the outlet housing to prevent shearing of the packings.

5. Tighten the packing nut just enough to prevent leaking. Overtightening can damage the packings.
6. Reconnect the displacement pump to the air motor as explained on page 11.

# Displacement Pump Parts

**Model 218113 Displacement Pump, Series A**  
200 Liter (55 Gallon) Size, Carbon Steel, Rubber Packed

**Model 218114 Displacement Pump, Series A**  
Stubby Size, Carbon Steel, Rubber Packed

Ref. No.	Part No.	Description	Qty.
1	177152	NUT, packing	1
2*	179925	BEARING; acetal	1
3*	107228	PACKING, u-cup; buna-N	3
4*	107227	O-RING; buna-N	1
5*	179924	WASHER; stainless steel	1
6	178542	HOUSING, outlet	1
7	101281	FITTING, grease	1
8	104537	O-RING; PTFE	2
9	214583	BUNG ADAPTER ASSY Includes items 10 and 12 (used on Model 218113 only)	1
10	172405	. BUSHING; nylon	1
12	222308	. ADAPTER, bung; carbon steel	1
13	172416	CYLINDER (Model 218113)	1
	177165	CYLINDER (Model 218114)	1
14	177156	O-RING; fluoroelastomer	1
15	217189	ROD, displacement	1
16	105775	NUT, hex; M14 x 1.5	2
17	177150	ROD, connecting (Model 218113)	1
	177160	ROD, connecting (Model 218114)	1
18	177168	HOUSING, valve, piston	1
19	177155	VALVE, piston	1
20	172393	WASHER; stainless steel	1
21*	177159	CUP, piston; polyethylene	1
22	177151	PISTON, pump	1
23	217102	VALVE, intake	1

## Model 218113 Shown

- △1 Torque to 31 N•m (23 ft-lb).
- △2 Torque to 33 N•m (24 ft-lb).
- △3 Lips of packing must face down.
- △4 Lips of packing must face up.
- △5 Used on Model 218113 only.

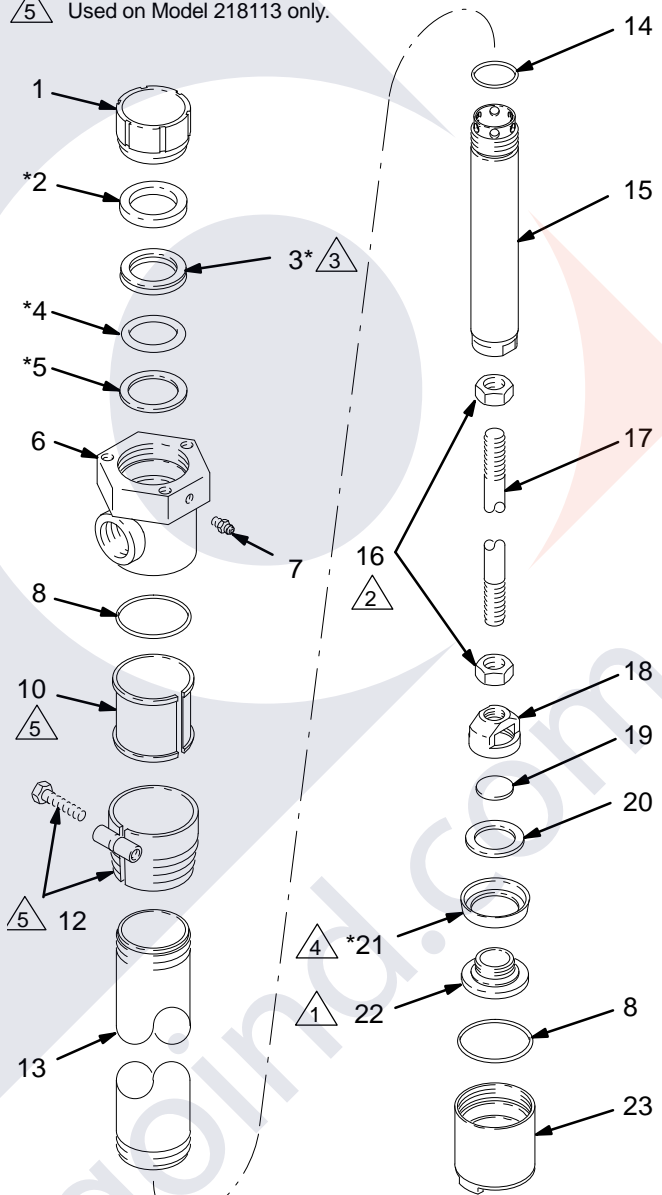

\* These parts are included in Repair Kit 218112, which may be purchased separately.

03774



# Displacement Pump Parts

**Model 218116 Displacement Pump, Series A**  
Adjustable Length, Carbon Steel, Rubber Packed

Ref. No.	Part No.	Description	Qty.	Ref. No.	Part No.	Description	Qty.
1	177152	NUT, packing	1	16	105775	NUT, hex; M14 x 1.5	2
2*	179925	BEARING; acetal	1	17	177160	ROD, connecting	1
3*	107228	PACKING, u-cup; buna-N	3	18	177168	HOUSING, valve, piston	1
4*	107227	O-RING; buna-N	1	19	177155	VALVE, piston	1
5*	179924	WASHER; stainless steel	1	20	172393	WASHER; stainless steel	1
6	178542	HOUSING, outlet	1	21*	177159	CUP, piston; polyethylene	1
7	101281	FITTING, grease	1	22	177151	PISTON, pump	1
8	104537	O-RING; PTFE	2	23	217102	VALVE, intake	1
9	214583	BUNG ADAPTER ASSY Includes items 10 and 12	1	33	179929	BUSHING, pipe; 1-1/2" x 3/4 npt	1
10	172405	BUSHING; nylon	1	34	179931	TUBE, suction, stationary	1
12	222308	ADAPTER, bung; carbon steel	1	35	179930	TUBE, suction, movable	1
13	177165	CYLINDER	1	36	104093	O-RING; buna-N	2
14	177156	O-RING; fluoroelastomer	1				
15	217189	ROD, displacement	1				

\* These parts are included in Repair Kit 218112, which may be purchased separately.

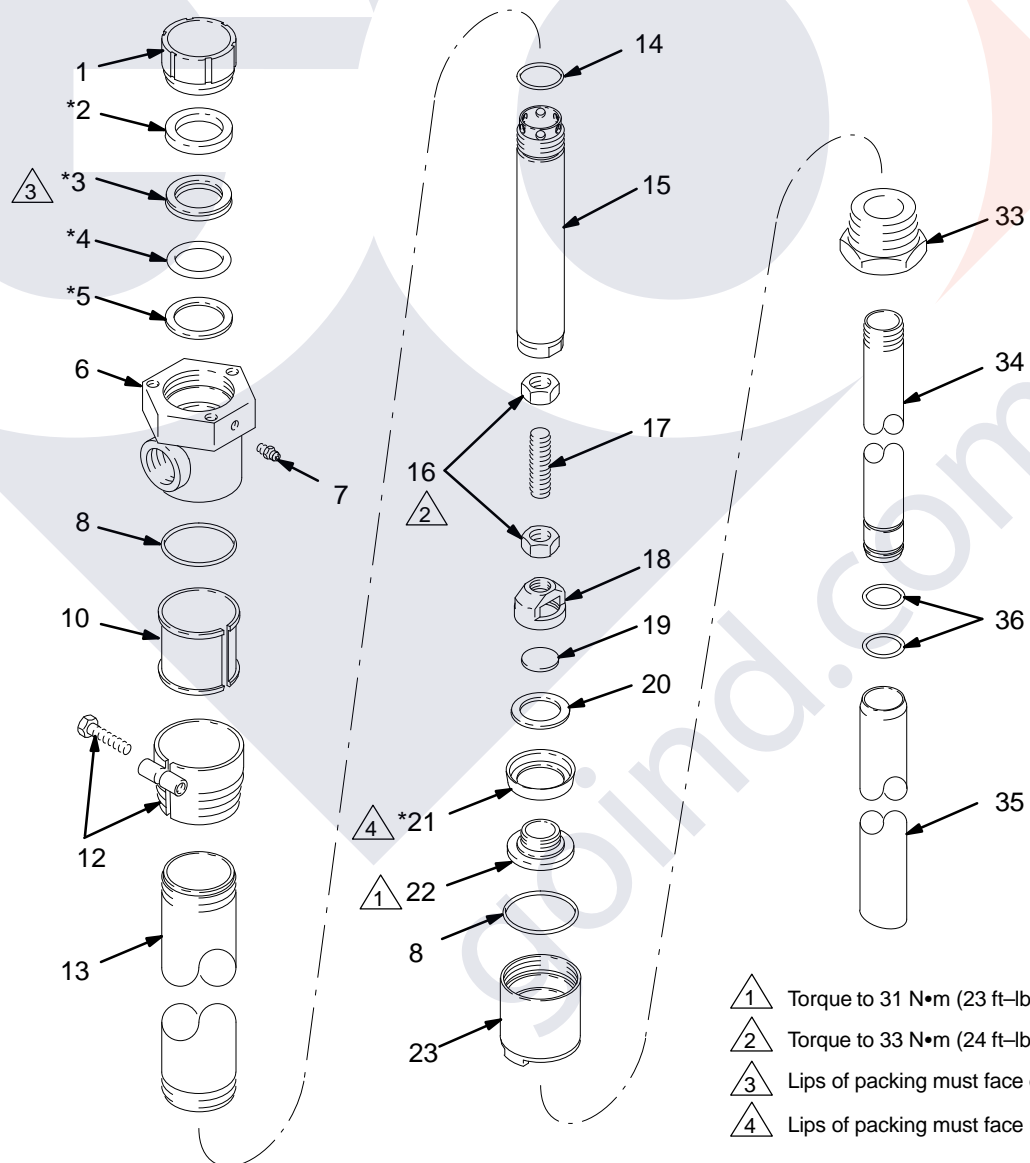

# Displacement Pump Service

## STAINLESS STEEL DISPLACEMENT PUMPS, with polyethylene, leather, or PTFE packings

This procedure covers the following displacement pumps. Refer to the parts drawings on the indicated pages for an illustration of your pump.

- Model 215955, page 27.
- Model 215958, page 28.
- Model 237253, page 30.
- Model 237256, page 31.

### Before You Start

1. Disconnect the displacement pump from the air motor as explained on page 11.
2. Be sure you have all the necessary repair parts on hand to reduce downtime.
3. Repair Kits are available. For best results, use all the new parts in the kit even if the old parts look good. Refer to the parts drawing for your pump.

### Intake Valve

1. Unscrew the intake valve housing (23) from the cylinder (13), using a strap wrench. Disassemble the valve and clean and inspect all parts.
2. Inspect the ball (28) and seat in the housing (23) for wear or nicks.
3. Replace parts as necessary. Reassemble as shown in the applicable parts drawing.

### Piston Valve

1. Using a strap wrench, grip the cylinder (13) near the outlet housing (6) and unscrew it from the housing. Pull the cylinder down off the piston. Check the inner surface of the cylinder for scoring or wear by running a finger over the surface or holding the part up to the light at an angle.
2. *On Models 215955 and 237253*, loosen the lower nut (16) and unscrew the valve housing (18) from the connecting rod (17). Unscrew the piston stud (22).

*On Models 215958 and 237256*, remove the cotter pins (29) from the ball stop pin (30). Remove the ball stop pin and unscrew the piston stud (22) from the displacement rod (15). Be careful not to drop the ball (25).

3. Clean and inspect all piston parts. Be sure to inspect the ball (25) and its seat on the piston stud (22) for wear or nicks. Replace parts as necessary. Reassemble the piston parts as shown, *being sure that the lips of the u-cup packing (21) are facing up*. Torque as specified on the applicable illustration. Using a strap wrench, grip the cylinder (13) near the outlet housing (6) and screw it into the housing.

**NOTE:** *On Models 215955 and 237253*, when reassembling the piston to the connecting rod (17), screw the connecting rod all the way into the displacement rod (15). Tighten the upper nut (16) against the displacement rod and torque to 33 N•m (24 ft–lb). Adjust the lower nut (16) to allow 3.1 mm (0.125 in.) free travel for the ball (25).

Also, when installing the cylinder (13), make sure that the knurled end is at the bottom.

### Throat Packings

1. Remove the cylinder (13) and piston as explained previously. Remove the packing nut (1) and pull the displacement rod (15) out of the top of the outlet housing (6). Inspect the outer surface of the displacement rod for scoring or wear by running a finger over the surface or holding it up to the light at an angle.
2. Remove the throat packings from the outlet housing (6).
3. Clean and inspect the parts for wear or damage. Lubricate the packings before reassembly. Install the parts one at a time, in the same position as before. *The lips of the v-packings must face down against fluid pressure.*
4. Leave the packing nut (1) loose until the displacement rod (15) has been installed.

### CAUTION

Insert the displacement rod from the top of the outlet housing to prevent shearing of the packings.

5. Tighten the packing nut just enough to prevent leaking. Overtightening can damage the packings.
6. Reconnect the displacement pump to the air motor as explained on page 11.

# Displacement Pump Parts

## Model 215955 Displacement Pump, Series B

200 Liter (55 Gallon) Size, Stainless Steel, Polyethylene Packed

Ref. No.	Part No.	Description	Qty.
1	180049	NUT, packing; stainless steel	1
2*	178543	GLAND, female; stainless steel	1
3*	177164	V-PACKING; polyethylene	3
5*	172385	GLAND, male; stainless steel	1
6	210876	HOUSING, outlet	1
8	104537	O-RING; PTFE	1
9	---	BUNG ADAPTER ASSY	1
		Includes items 10, 11, and 12	1
10	172405	. BUSHING; nylon	1
11	104587	. BOLT, M8 x 1.25	1
12	210877	. ADAPTER, bung; stainless steel	1
13	178863	CYLINDER, 55 gal.; stainless steel	1
14	177156	O-RING; fluoroelastomer	1
15	217211	ROD, displacement	1
16	105776	NUT, hex; M14 x 1.5	2
17	177149	ROD, connecting	1
18	177175	HOUSING, valve, piston	1
20	172393	WASHER; stainless steel	1
21*	177159	CUP, piston; polyethylene	1
22	172495	STUD, piston; stainless steel	1
23	218427	VALVE, intake; stainless steel	1
24	172391	SPACER, piston; PTFE	1
25	104585	BALL, piston; 22 mm dia.	1
26	172399	PIN, ball stop	1
27	177230	GUIDE, ball	1
28	104586	BALL, intake; 32 mm dia.	1

\* These parts are included in Repair Kit 215964, which may be purchased separately.

- 1 Torque to 65 N•m (47 ft-lb).
- 2 Torque to 33 N•m (24 ft-lb).
- 3 Lips of packing must face down.
- 4 Lips of packing must face up.
- 5 Knurl is at the bottom end.

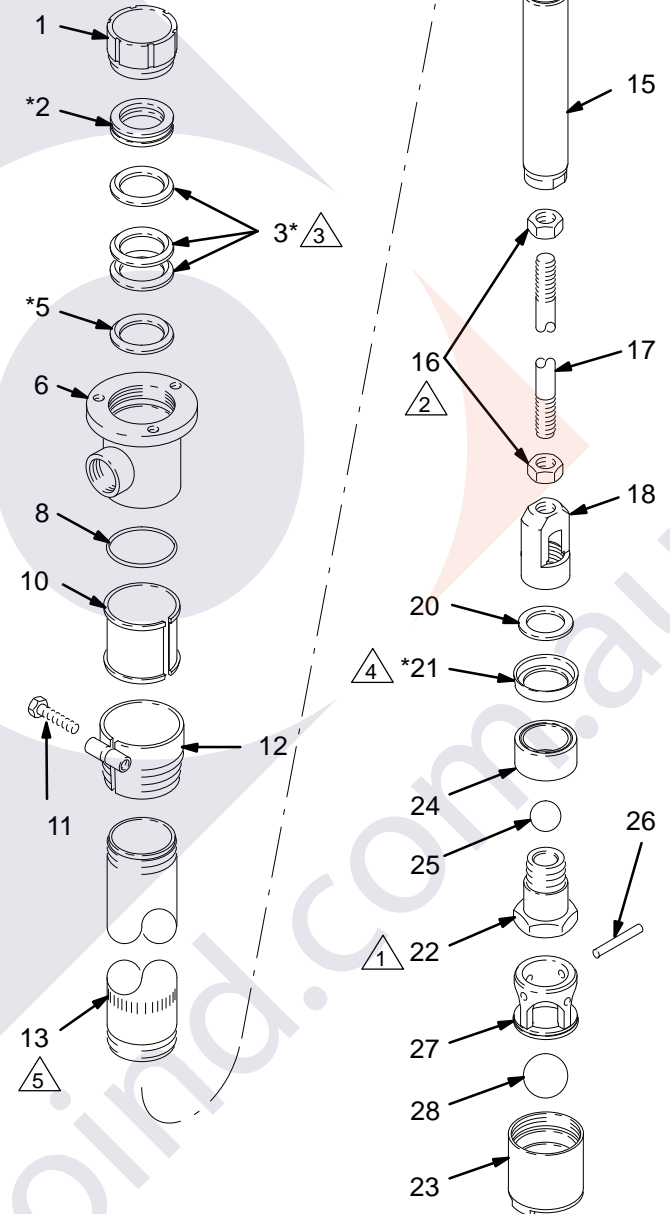

03775A

# Displacement Pump Parts

## Model 215958 Displacement Pump, Series B Stubby Size, Stainless Steel, Polyethylene Packed

Ref. No.	Part No.	Description	Qty.
1	180049	NUT, packing; stainless steel	1
2*	178543	GLAND, female; stainless steel	1
3*	177164	V-PACKING; polyethylene	3
5*	172385	GLAND, male; stainless steel	1
6	210876	HOUSING, outlet	1
8	104537	O-RING; PTFE	1
13	172494	CYLINDER, stubby	1
14	177156	O-RING; fluoroelastomer	1
15	217212	ROD, displacement	1
20	172393	WASHER; stainless steel	1
21*	177159	CUP, piston; polyethylene	1
22	172495	STUD, piston	1
23	218427	VALVE, intake; stainless steel	1
24	172391	SPACER, piston; PTFE	1
25	104585	BALL, piston; 22 mm dia.	1
26	172399	PIN, ball stop	1
27	177230	GUIDE, ball	1
28	104586	BALL, intake; 32 mm dia.	1
29	100063	PIN, cotter	2
30	172389	PIN, ball stop	1

\* These parts are included in Repair Kit 215964, which may be purchased separately.

- △1 Torque to 31 N•m (23 ft-lb).
- △2 Torque to 33 N•m (24 ft-lb).
- △3 Lips of v-packings must face down.
- △4 Lips of packing must face up.

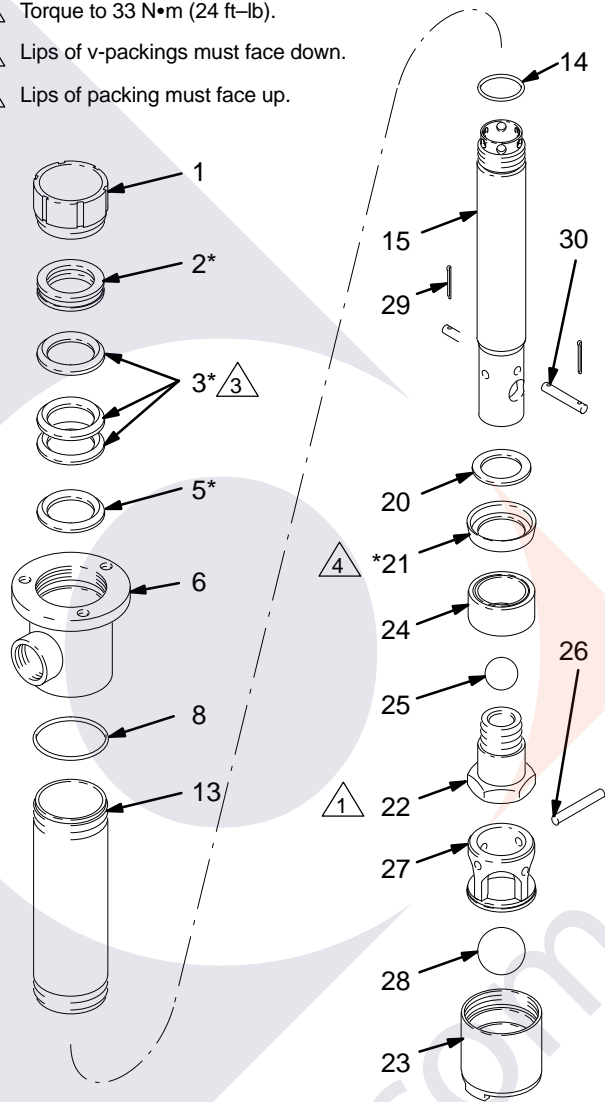

03781

# Notes

---

---

---

---

---

---

---

---

---

---

---

---

---

---

---

---

---

---

---

---

---

---

---

---

---

---

[goind.com.au](http://goind.com.au)

# Displacement Pump Parts

**Model 237253 Displacement Pump, Series A**  
 200 Liter (55 Gallon) Size, Stainless Steel, PTFE Packed

Ref. No.	Part No.	Description	Qty.
1	180049	NUT, packing; stainless steel	1
2*	178543	GLAND, female; stainless steel	1
3*	172487	V-PACKING; PTFE	3
5*	172385	GLAND, male; stainless steel	1
6	210876	HOUSING, outlet	1
8	104537	O-RING; PTFE	1
10	172405	BUSHING; nylon	1
11	104587	BOLT, M8 x 1.25	1
12	210877	ADAPTER, bung; stainless steel	1
13	178863	CYLINDER, 55 gal.; stainless steel	1
14	177156	O-RING; fluoroelastomer	1
15	217211	ROD, displacement	1
16	105776	NUT, hex; M14 x 1.5	2
17	177149	ROD, connecting	1
18	177175	HOUSING, valve, piston	1
20	172393	WASHER; stainless steel	1
21*	172489	CUP, piston; PTFE	1
22	172495	STUD, piston; stainless steel	1
23	218427	VALVE, intake; stainless steel	1
24	172391	SPACER, piston; PTFE	1
25	104585	BALL, piston; 22 mm dia.	1
26	172399	PIN, ball stop	1
27	177230	GUIDE, ball	1
28	104586	BALL, intake; 32 mm dia.	1

- △ 1 Torque to 65 N•m (47 ft-lb).
- △ 2 Torque to 33 N•m (24 ft-lb).
- △ 3 Lips of packing must face down.
- △ 4 Lips of packing must face up.
- △ 5 Knurl is at the bottom end.

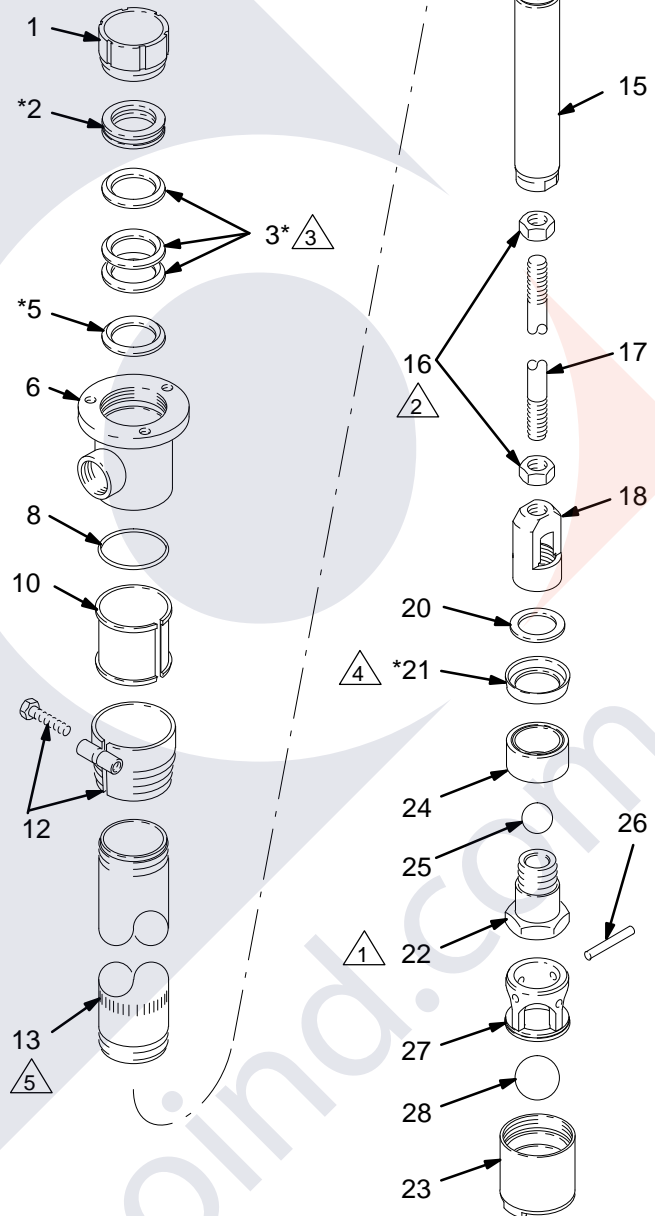

\* These parts are included in Repair Kit 213013, which may be purchased separately.

03775A

# Displacement Pump Parts

## Model 237256 Displacement Pump, Series A Stubby Size, Stainless Steel, PTFE Packed

Ref. No.	Part No.	Description	Qty.
1	180049	NUT, packing; stainless steel	1
2*	178543	GLAND, female; stainless steel	1
3*	172487	V-PACKING; PTFE	3
5*	172385	GLAND, male; stainless steel	1
6	210876	HOUSING, outlet	1
8	104537	O-RING; PTFE	1
13	172494	CYLINDER, stubby	1
14	177156	O-RING; fluoroelastomer	1
15	217212	ROD, displacement	1
20	172393	WASHER; stainless steel	1
21*	172489	CUP, piston; PTFE	1
22	172495	STUD, piston	1
23	218427	VALVE, intake; stainless steel	1
24	172391	SPACER, piston; PTFE	1
25	104585	BALL, piston; 22 mm dia.	1
26	172399	PIN, ball stop	1
27	177230	GUIDE, ball	1
28	104586	BALL, intake; 32 mm dia.	1
29	100063	PIN, cotter	2
30	172389	PIN, ball stop	1

\* These parts are included in Repair Kit 213013, which may be purchased separately.

- 1 Torque to 31 N•m (23 ft-lb).
- 2 Torque to 33 N•m (24 ft-lb).
- 3 Lips of v-packings must face down.
- 4 Lips of packing must face up.

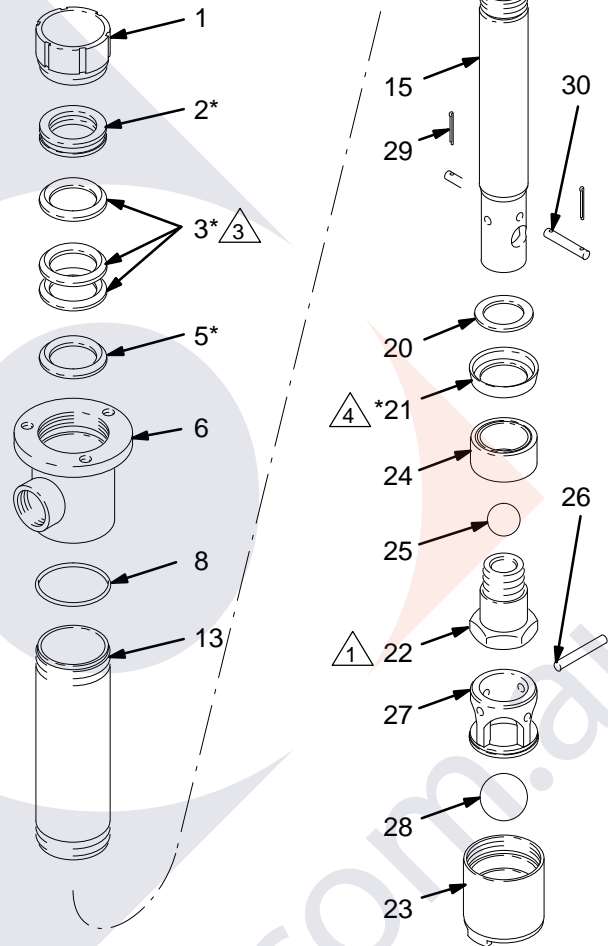

03781

# Displacement Pump Service

## STAINLESS STEEL DISPLACEMENT PUMPS, with rubber packings

This procedure covers the following displacement pumps. Refer to the parts drawings on the indicated pages for an illustration of your pump.

- Model 220440, page 33.
- Model 220439, page 34.

### Before You Start

1. Disconnect the displacement pump from the air motor as explained on page 11.
2. Be sure you have all the necessary repair parts on hand to reduce downtime.
3. Repair Kit 218112 is available. For best results, use all the new parts in the kit even if the old parts look good.

### Intake Valve

1. Unscrew the intake valve housing (23) from the cylinder (13), using a strap wrench. Disassemble the valve and clean and inspect all parts.
2. Inspect the ball (28) and seat in the housing (23) for wear or nicks.
3. Replace parts as necessary. Reassemble as shown in the applicable parts drawing.

### Piston Valve

1. Using a strap wrench, grip the cylinder (13) near the outlet housing (6) and unscrew it from the housing. Pull the cylinder down off the piston. Check the inner surface of the cylinder for scoring or wear by running a finger over the surface or holding the part up to the light at an angle.
2. *On Model 220440*, loosen the lower nut (16) and unscrew the valve housing (18) from the connecting rod (17). Unscrew the piston stud (22).

*On Model 220439*, remove the cotter pins (29) from the ball stop pin (30). Remove the ball stop pin and unscrew the piston stud (22) from the displacement rod (15). Be careful not to drop the ball (25).

3. Clean and inspect all piston parts. Be sure to inspect the ball (25) and its seat on the piston stud (22) for wear or nicks. Replace parts as necessary. Reassemble the piston parts as shown, *being sure that the lips of the u-cup packing (21) are facing up*. Torque as specified on the applicable illustration. Using a strap wrench, grip the cylinder (13) near the outlet housing (6) and screw it into the housing.

**NOTE:** *On Model 220440*, when reassembling the piston to the connecting rod (17), screw the connecting rod all the way into the displacement rod (15). Tighten the upper nut (16) against the displacement rod and torque to 33 N•m (24 ft–lb). Adjust the lower nut (16) to allow 3.1 mm (0.125 in.) free travel for the ball (25).

Also, when installing the cylinder (13), make sure that the knurled end is at the bottom.

### Throat Packings

1. Remove the cylinder (13) and piston as explained previously. Remove the packing nut (1) and pull the displacement rod (15) out of the top of the outlet housing (6). Inspect the outer surface of the displacement rod for scoring or wear by running a finger over the surface or holding it up to the light at an angle.
2. Remove the throat packings from the outlet housing (6).
3. Clean and inspect the parts for wear or damage. Lubricate the packings before reassembly. Install the parts one at a time, in the same position as before. *The lips of the u-cup must face down against fluid pressure.*
4. Leave the packing nut (1) loose until the displacement rod (15) has been installed.

### CAUTION

Insert the displacement rod from the top of the outlet housing to prevent shearing of the packings.

5. Tighten the packing nut just enough to prevent leaking. Overtightening can damage the packings.
6. Reconnect the displacement pump to the air motor as explained on page 11.



# Displacement Pump Parts

## Model 220440 Displacement Pump, Series A

200 Liter (55 Gallon) Size, Stainless Steel, Rubber Packed

Ref. No.	Part No.	Description	Qty.
1	180049	NUT, packing; stainless steel	1
2*	179925	BEARING; acetal	1
3*	107228	PACKING, u-cup; rubber	1
4*	107227	O-RING; buna-N	1
5*	179924	WASHER; stainless steel	1
6	210876	HOUSING, outlet	1
8	104537	O-RING; PTFE	1
9	—	BUNG ADAPTER ASSY Includes items 10, 11, and 12	1
10	172405	. BUSHING; nylon	1
11	104587	. BOLT, M8 x 1.25	1
12	210877	. ADAPTER, bung; stainless steel	1
13	178863	CYLINDER, 55 gal.; stainless steel	1
14	177156	O-RING; fluoroelastomer	1
15	217211	ROD, displacement	1
16	105776	NUT, hex; M14 x 1.5	2
17	177149	ROD, connecting	1
18	177175	HOUSING, valve, piston	1
20	172393	WASHER; stainless steel	1
21*	177159	CUP, piston; polyethylene	1
22	172495	STUD, piston; stainless steel	1
23	218427	VALVE, intake; stainless steel	1
24	172391	SPACER, piston; PTFE	1
25	104585	BALL, piston; 22 mm dia.	1
26	172399	PIN, ball stop	1
27	177230	GUIDE, ball	1
28	104586	BALL, intake; 32 mm dia.	1

\* These parts are included in Repair Kit 218112, which may be purchased separately.

- △1 Torque to 65 N•m (47 ft-lb).
- △2 Torque to 33 N•m (24 ft-lb).
- △3 Lips of packing must face down.
- △4 Lips of packing must face up.
- △5 Knurl is at the bottom end.

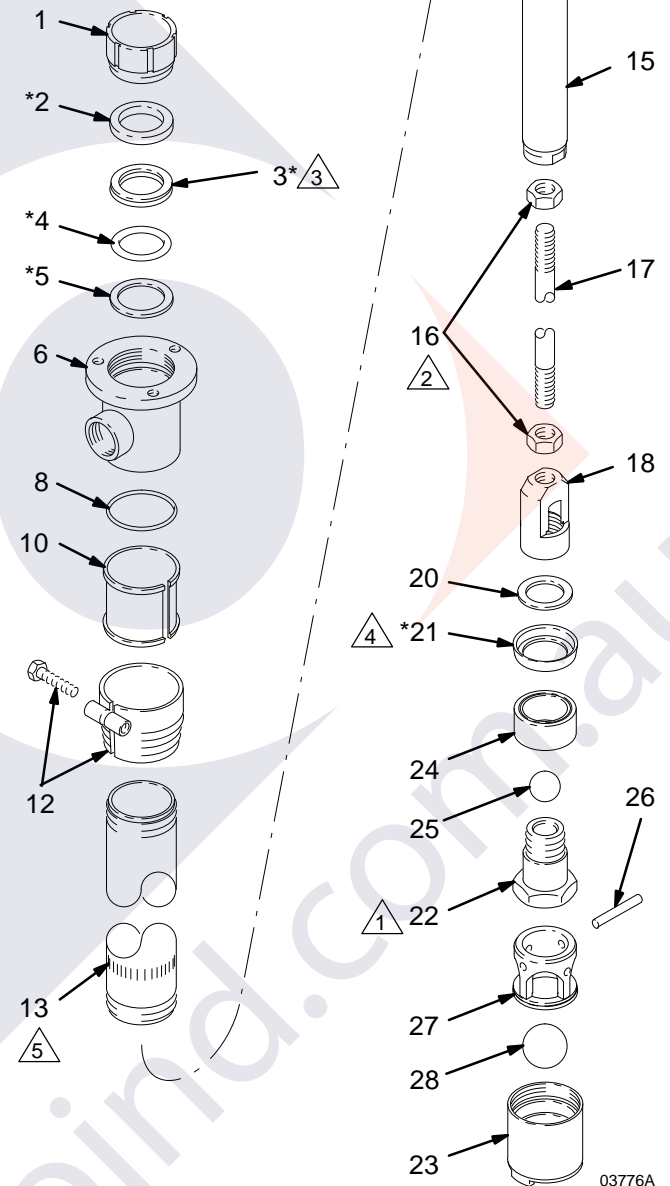

03776A

# Displacement Pump Parts

## Model 220439 Displacement Pump, Series A Stubby Size, Stainless Steel, Rubber Packed

Ref. No.	Part No.	Description	Qty.
1	180049	NUT, packing; stainless steel	1
2*	179925	BEARING; acetal	1
3*	107228	PACKING, u-cup; rubber	1
4*	107227	O-RING; buna-N	1
5*	179924	WASHER; stainless steel	1
6	210876	HOUSING, outlet	1
8	104537	O-RING; PTFE	1
13	172494	CYLINDER, stubby	1
14	177156	O-RING; fluoroelastomer	1
15	217212	ROD, displacement	1
20	172393	WASHER; stainless steel	1
21*	177159	CUP, piston; polyethylene	1
22	172495	STUD, piston	1
23	218427	VALVE, intake; stainless steel	1
24	172391	SPACER, piston; PTFE	1
25	104585	BALL, piston; 22 mm dia.	1
26	172399	PIN, ball stop	1
27	177230	GUIDE, ball	1
28	104586	BALL, intake; 32 mm dia.	1
29	100063	PIN, cotter	2
30	172389	PIN, ball stop	1

\* These parts are included in Repair Kit 218112, which may be purchased separately.

- △ 1 Torque to 31 N•m (23 ft-lb).
- △ 2 Torque to 33 N•m (24 ft-lb).
- △ 3 Lips of v-packings must face down.
- △ 4 Lips of packing must face up.

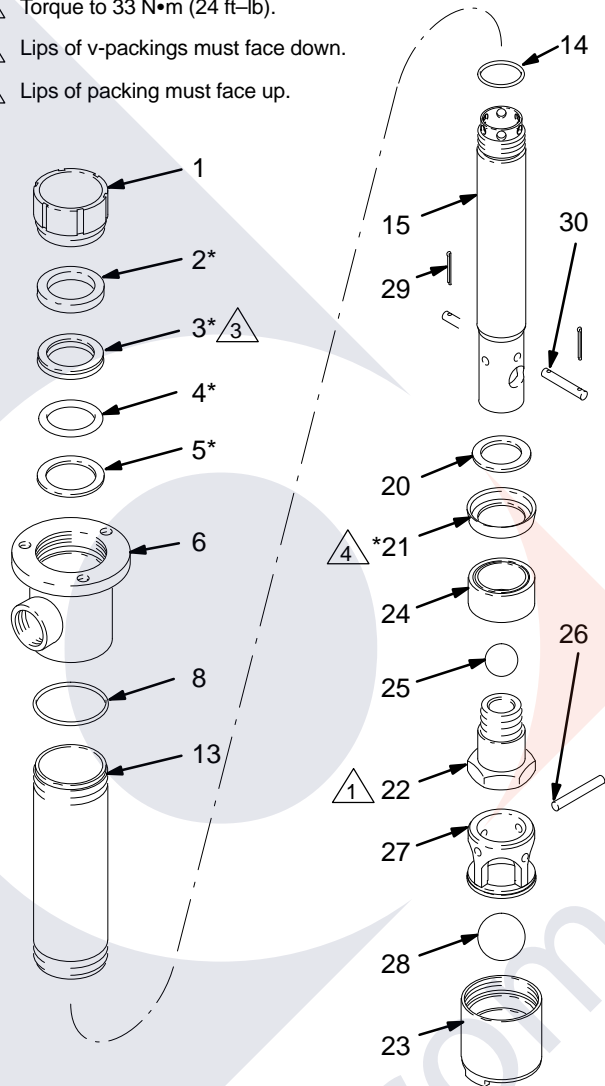

03782

# Accessories

## 210881 Wall Mounting Bracket

Carbon Steel. See manual 307458.

1	107558	SCREW, hex hd cap; M8 x 1.25	2
2	104572	LOCKWASHER, spring, Size 8	2
3	172405	BUSHING	1
4	172428	BRACKET	1
5	172429	CLAMP	1

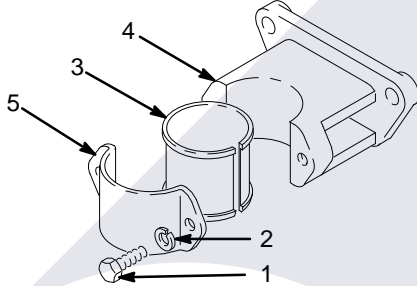

## 210880 Open Tank Mounting Clamp

Carbon Steel.

1	107558	SCREW, hex hd cap; M8 x 1.25	2
2	104572	LOCKWASHER, spring, Size 8	2
3	159056	PAD, screw mounting	1
4	159057	RETAINER	1
5	172405	BUSHING	1
6	172427	BRACKET	1
7	172429	CLAMP	1
8	210879	HANDLE, tee	1

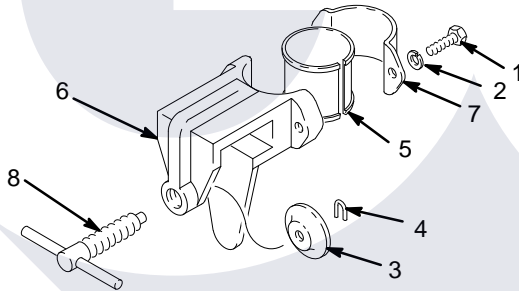

## Bung Adapters

Included with all 210 liter (55 gallon) drum size pumps.

### 214583 Carbon Steel

1	172405	BUSHING, nylon	1
2	222308	ADAPTER, bung, cst	1
	210877	ADAPTER, bung, sst	1

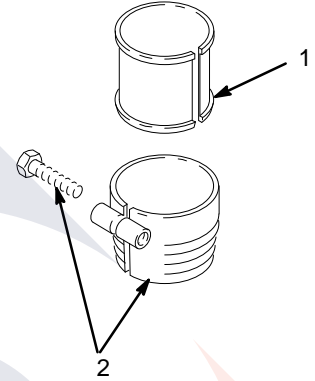

goind.com.au

# Accessories

## 222011 Ground Wire and Clamp

7.6 m (25 ft) long.

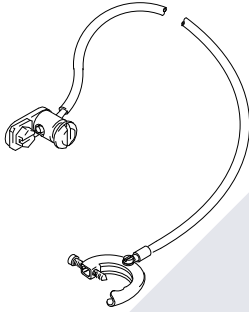

## 237569 Ground Wire and Clamp

7.6 m (25 ft) long.

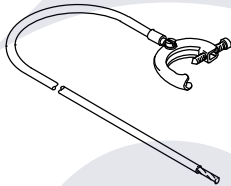

## Bleed-Type Master Air Valve (Required)

*2.1 MPa, 21 bar (300 psi) Maximum Working Pressure*  
Relieves air trapped in the air line between the pump air inlet and this valve when closed.

107141 3/4 npt(m x f) inlet and outlet.

107142 1/2 npt(m x f) inlet and outlet.

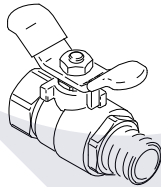

## 106149 Air Line Filter

*1.8 MPa, 18 bar (250 psi) Maximum Working Pressure*  
1/2 npt(f) inlet and outlet.

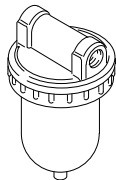

## 214848 Air Line Lubricator

*1.8 MPa, 18 bar (250 psi) Maximum Working Pressure*  
1/2 npt(f) inlet and outlet.

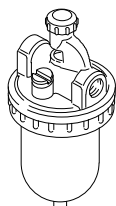

## 218316 Air Regulator Kit

Includes 1/8" size, 0–0.4 MPa, 0–4.2 bar (0–60 psi) air regulator and air pressure gauge, and air quick coupler. See page 16.

## 206994 Throat Seal Liquid (TSL)

Solvent for wet-cup. 0.24 liter (8 oz.).

## 204574 Drum Cover

40 liter (10 gallon) size and 60 liter (16 gallon) size. Drum cover mounts on top of an open drum, with mounting holes for 1:1 metric pump. Includes thumb-screws and a rubber gasket.

## 200326 Drum Cover

200 liter (55 gallon) size. Drum cover mounts on top of an open drum, with mounting for 1:1 metric pump.

## 101078 Y Line Strainer

*3.5 MPa, 35 bar (500 psi) Maximum Working Pressure*  
3/4 npt(f) ports; no. 20 mesh screen.

## 206265 Spout

For directing fluid into pails.  
Carbon steel; 3/4 npt inlet.

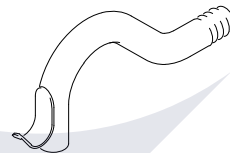

## 215965 Intake Extension Tube

Intake tube 265 mm (10.4 in.) long; screws into bottom 1–1/2 npt(f) thread of 1:1 metric pump. Carbon steel. See manual 307459.



## 214951 Hose and 238651 Valve

*1.2 MPa, 12 bar (175 psi) Maximum Working Pressure*  
7.6 m (25 ft) long, 1/2 npt(m) x 3/4 npt(m), electrically conductive.

# Dimensions

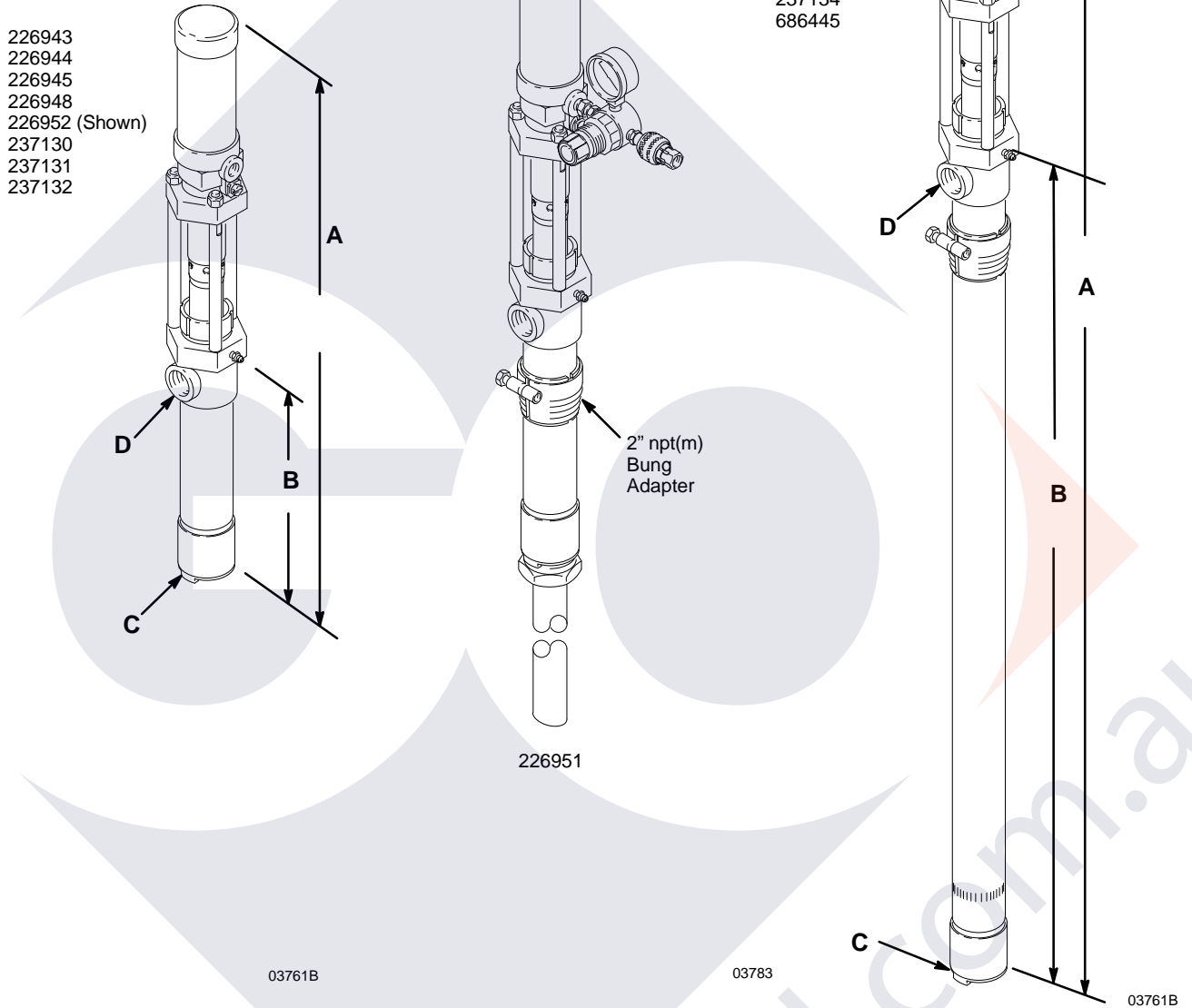

Pump No.	A Overall Length	B Pump Length	C Fluid Inlet	D Fluid Outlet
226943, 226944, 226948, 237130, 237131	615 mm (34 in.)	181 mm (7.1 in.)	1-1/2 in. npt(f)	3/4 in. npt(f)
226945, 226952, 237132	685 mm (27 in.)	250 mm (9.8 in.)	1-1/2 in. npt(f)	3/4 in. npt(f)
226940, 226941, 226942, 226947, 226953, 237129, 237133, 237134, 686445	1315 mm (51.7 in.)	880 mm (34.6 in.)	1-1/2 in. npt(f)	3/4 in. npt(f)
226951	1158 mm (45.6 in.)	724 mm* (28.5 in.)	Suction Tube	3/4 in. npt(f)

\*Extends to 1614 mm (63.5 in.) overall; the pump length to 1180 mm (46.4 in.)

# Technical Data

Category	Data
Recommended air operating range	<i>Model 226951:</i> 0.3 to 0.4 MPa, 3 to 4.2 bar (0 to 60 psi) <i>All Other Models:</i> 0.3 to 1.2 MPa, 3 to 12 bar (40 to 180 psi)
Air consumption	Approx. 0.05 m <sup>3</sup> /min (1.5 cfm/gal) at 4 liters/min (1 gpm) at 0.5 MPa, 5.6 bar (80 psi) input
Maximum recommended pump speed	100 cycles/min: 15.1 liters/min (4 gpm)
Air inlet size	1/4 npt(f)
Fluid inlet size	1–1/2 npt(f)
Fluid outlet size	3/4 npt(f)
Maximum Operating Temperature	120°F (49°C)
Sound Pressure Level	at 100 psi (0.7 MPa, 7 bar): 72 dB(A) at 65 psi (0.45 MPa, 4.5 bar): 70 dB(A)
Sound Power Level	at 100 psi (0.7 MPa, 7 bar): 82 dB(A) at 65 psi (0.45 MPa, 4.5 bar): 81 dB(A)
Weight	<i>Stubby Pump:</i> 11 lbs (5 kg) <i>Drum Pump:</i> 20 lbs (9 kg)
Wetted parts	<p><i>Models 226940, 226943, 237130, and 237133:</i> Carbon Steel, 303, 304 and 316 Stainless Steel, Leather, Cadmium-Plated Ductile Iron, Chrome and Zinc-Plated Steel, PTFE, fluoroelastomer</p> <p><i>Models 226941, 226944, and 686445:</i> Carbon Steel, 303, 304 and 316 Stainless Steel, Cadmium-Plated Ductile Iron, Chrome and Zinc-Plated Steel, PTFE, fluoroelastomer, Polyethylene</p> <p><i>Model 237131 and 237134:</i> Carbon Steel, 303, 304 and 316 Stainless Steel, Cadmium-Plated Ductile Iron, Chrome and Zinc-Plated Steel, PTFE, fluoroelastomer</p> <p><i>Models 226942 and 226945:</i> 303, 304 and 316 Stainless Steel, Chrome, PTFE, fluoroelastomer, Polyethylene</p> <p><i>Models 237129 and 237132:</i> 303, 304 and 316 Stainless Steel, Chrome, PTFE, fluoroelastomer, Polyethylene</p> <p><i>Models 226947, 226948, and 226951:</i> 303, 304 and 316 Stainless Steel, Buna-N, Cadmium-Plated Ductile Iron, Chrome and Zinc-Plated Steel, PTFE, fluoroelastomer, Polyethylene</p> <p><i>Models 226952 and 226953:</i> 303, 304 and 316 Stainless Steel, Chrome, PTFE, Rubber</p>



# The Graco Standard Warranty

Graco warrants all equipment manufactured by Graco and bearing its name to be free from defects in material and workmanship on the date of sale to the original purchaser for use. With the exception of any special, extended, or limited warranty published by Graco, Graco will, for a period of twelve months from the date of sale, repair or replace any part of the equipment determined by Graco to be defective. This warranty applies only when the equipment is installed, operated and maintained in accordance with Graco's written recommendations.

This warranty does not cover, and Graco shall not be liable for general wear and tear, or any malfunction, damage or wear caused by faulty installation, misapplication, abrasion, corrosion, inadequate or improper maintenance, negligence, accident, tampering, or substitution of non-Graco component parts. Nor shall Graco be liable for malfunction, damage or wear caused by the incompatibility of Graco equipment with structures, accessories, equipment or materials not supplied by Graco, or the improper design, manufacture, installation, operation or maintenance of structures, accessories, equipment or materials not supplied by Graco.

This warranty is conditioned upon the prepaid return of the equipment claimed to be defective to an authorized Graco distributor for verification of the claimed defect. If the claimed defect is verified, Graco will repair or replace free of charge any defective parts. The equipment will be returned to the original purchaser transportation prepaid. If inspection of the equipment does not disclose any defect in material or workmanship, repairs will be made at a reasonable charge, which charges may include the costs of parts, labor, and transportation.

**THIS WARRANTY IS EXCLUSIVE, AND IS IN LIEU OF ANY OTHER WARRANTIES, EXPRESS OR IMPLIED, INCLUDING BUT NOT LIMITED TO WARRANTY OF MERCHANTABILITY OR WARRANTY OF FITNESS FOR A PARTICULAR PURPOSE.**

Graco's sole obligation and buyer's sole remedy for any breach of warranty shall be as set forth above. The buyer agrees that no other remedy (including, but not limited to, incidental or consequential damages for lost profits, lost sales, injury to person or property, or any other incidental or consequential loss) shall be available. Any action for breach of warranty must be brought within two (2) years of the date of sale.

Graco makes no warranty, and disclaims all implied warranties of merchantability and fitness for a particular purpose in connection with accessories, equipment, materials or components sold but not manufactured by Graco. These items sold, but not manufactured by Graco (such as electric motors, switches, hose, etc.), are subject to the warranty, if any, of their manufacturer. Graco will provide purchaser with reasonable assistance in making any claim for breach of these warranties.

In no event will Graco be liable for indirect, incidental, special or consequential damages resulting from Graco supplying equipment hereunder, or the furnishing, performance, or use of any products or other goods sold hereto, whether due to a breach of contract, breach of warranty, the negligence of Graco, or otherwise.

## **FOR GRACO CANADA CUSTOMERS**

The parties acknowledge that they have required that the present document, as well as all documents, notices and legal proceedings entered into, given or instituted pursuant hereto or relating directly or indirectly hereto, be drawn up in English. Les parties reconnaissent avoir convenu que la rédaction du présente document sera en Anglais, ainsi que tous documents, avis et procédures judiciaires exécutés, donnés ou intentés à la suite de ou en rapport, directement ou indirectement, avec les procédures concernées.

## Graco Information

For the latest information about Graco products, visit [www.graco.com](http://www.graco.com).  
For patent information, see [www.graco.com/patents](http://www.graco.com/patents).

**TO PLACE AN ORDER**, contact your Graco distributor or call to identify the distributor closest to you:  
**Phone:** 612-623-6921 or **Toll Free:** 1-800-328-0211 **Fax:** 612-378-3505

*All written and visual data contained in this document reflects the latest product information available at the time of publication.  
Graco reserves the right to make changes at any time without notice.*

Original instructions. This manual contains English. MM 307427

**Graco Headquarters:** Minneapolis  
**International Offices:** Belgium, China, Japan, Korea

**GRACO INC. AND SUBSIDIARIES • P.O. BOX 1441 • MINNEAPOLIS MN 55440-1441 • USA**  
Copyright 1980, Graco Inc. All Graco manufacturing locations are registered to ISO 9001.

[www.graco.com](http://www.graco.com)

Revision ZAC, February 2016