

# LineLazer™ V 200HS & 200DC Airless Line Stripers

## Standard Series and High Production (HP) Series

3A3426H  
EN

**For the application of line striping materials.**  
**For professional use only.**  
**For outdoor use only.**  
**Not for use in explosive atmospheres or hazardous locations.**

Maximum Operating Pressure: 3300 psi (22.8 MPa, 228 bar)



### Important Safety Instructions

Read all warnings and instructions in this manual and in related manuals before using the equipment.  
 Be familiar with the controls and the proper usage of the equipment.  
 Save these instructions.

Related Manuals:			
3A3390	Parts	309277	Pump
311254	Gun	3A3428	Auto-Layout Applications Methods

LineLazer V 200HS  
Standard Series

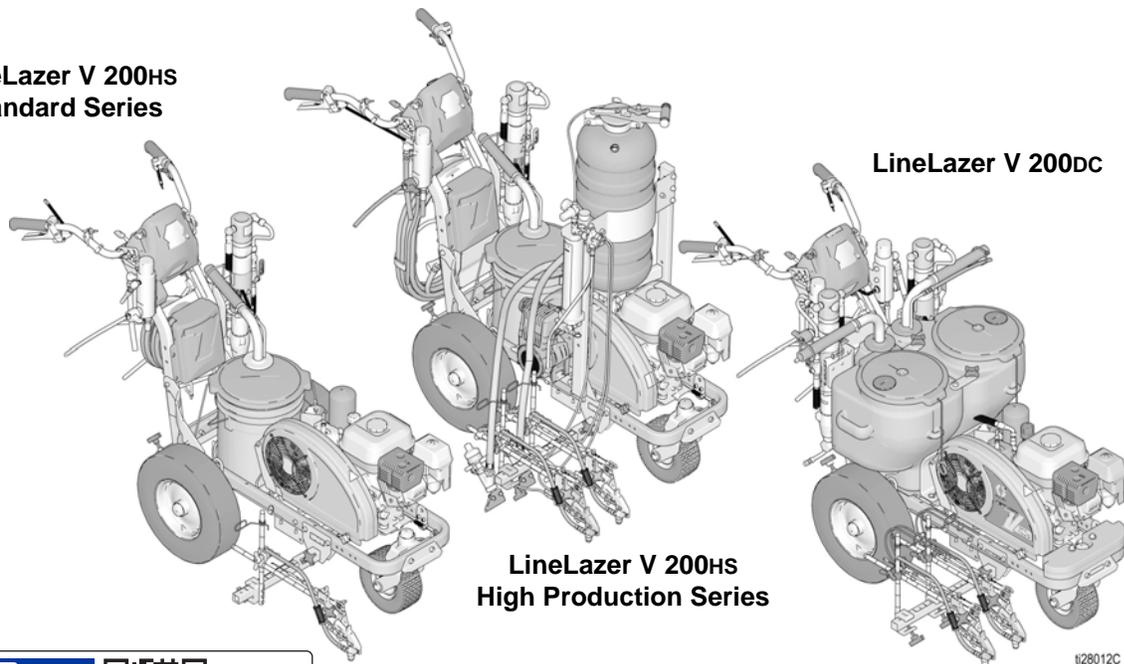

LineLazer V 200HS  
High Production Series

LineLazer V 200DC

t28012C



Use only genuine Graco replacement parts.  
 The use of non-Graco replacement parts may void warranty.

# Standard Series

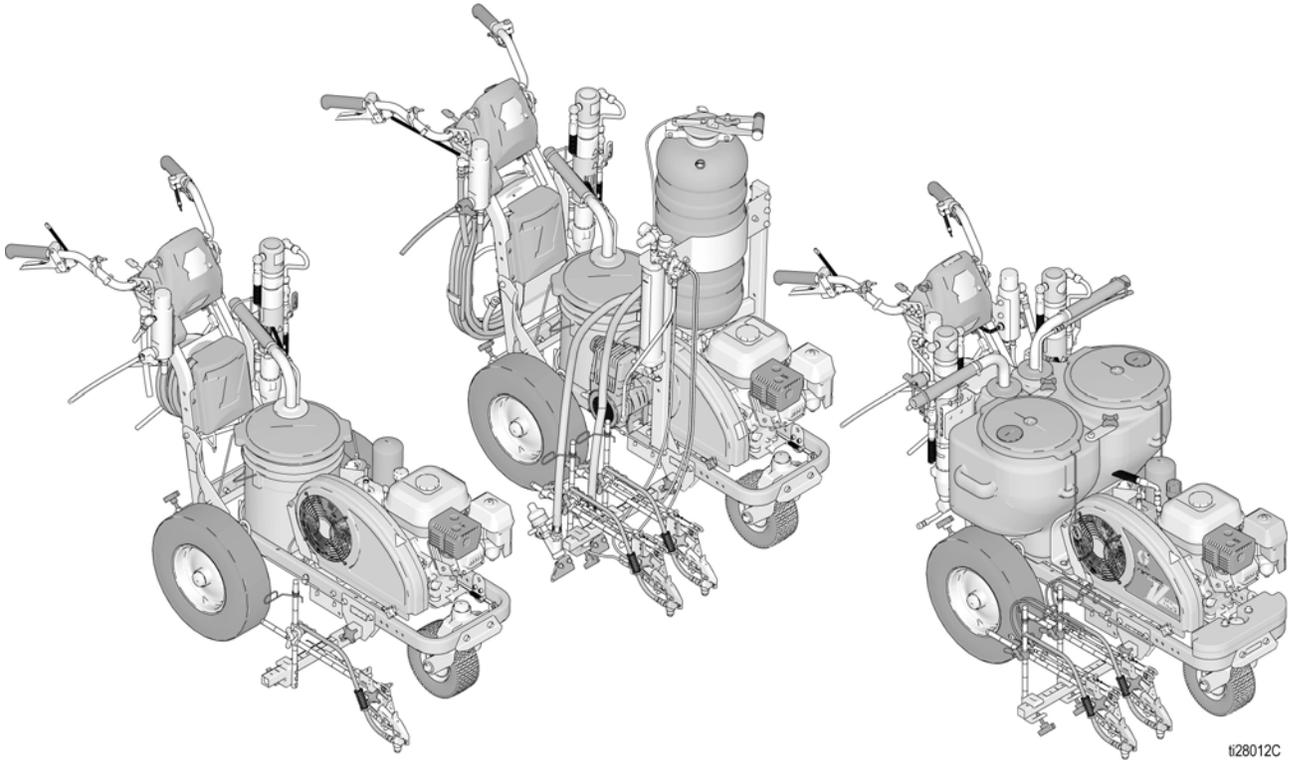

1128012C

# LineLazer V LiveLook Display

## Standard Series

### 200DC

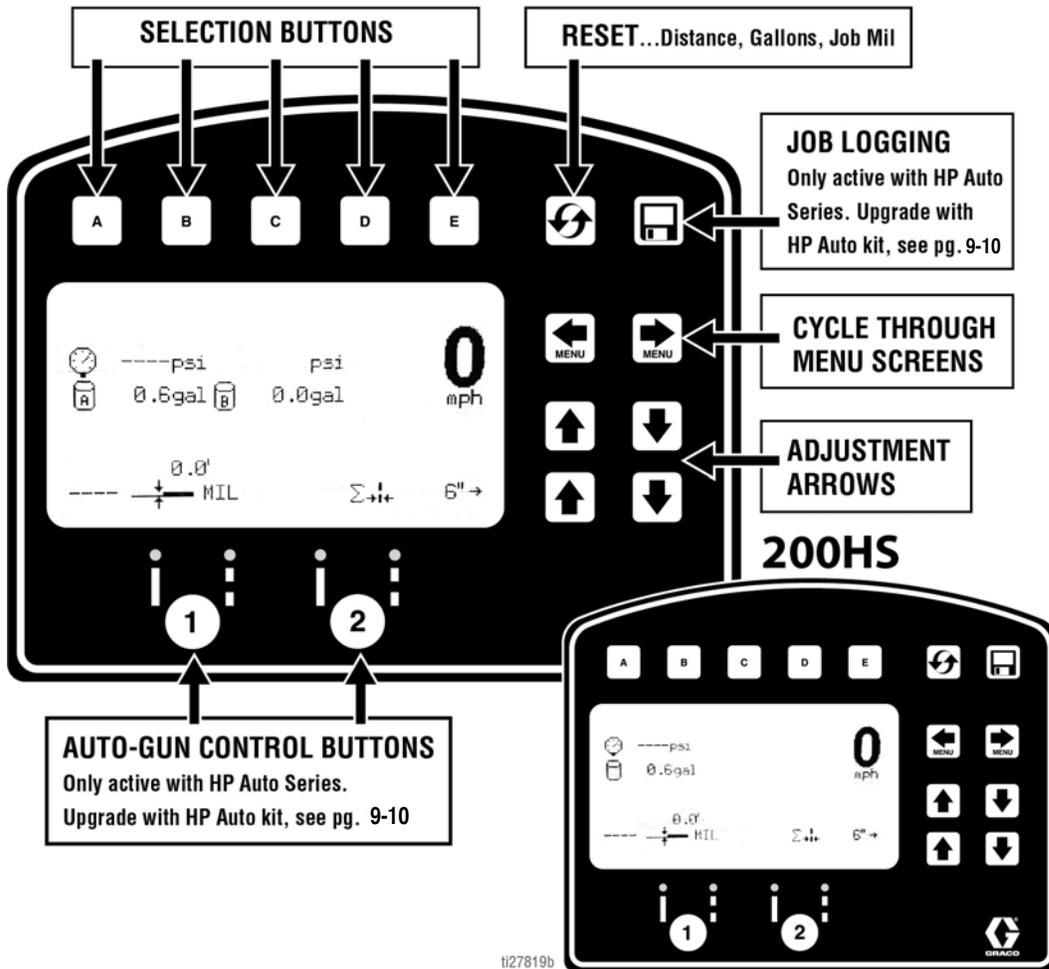

t127819b

### STRIPING SCREEN

200DC

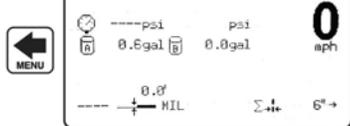

200HS

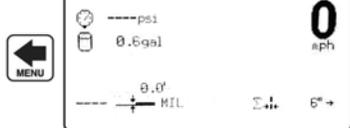

- Displays:
  - Distance of sprayed line
  - Gallons Pumped
  - Job Mil and Live Mil
  - Speed
  - Pressure
  - Input Line Width

### MEASURE MODE

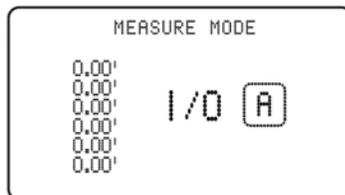

- Take up to 6 measurements by pressing the [A] button to start the measurement and pressing it again to end the measurement.

### SETTING/INFO

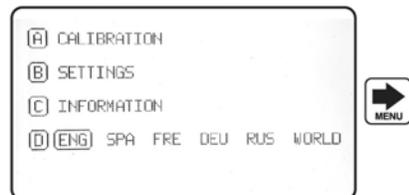

- Settings and information can be accessed from this screen.
- For accurate distance calculations, the machine must be calibrated. Press [A] to calibrate the machine. Use a distance of at least 25 feet or more.

t127820b

## Initial Setup (Standard Series)

The initial setup prepares the striper for operation based on a number of user entered parameters. Language selections and the units of measure selections can be set before you start or changed later.

### Language

From Setup/Information select appropriate language by pressing **D** until the language is outlined.



ENG = English  
 SPA = Spanish  
 FRE = French  
 DEU = German  
 RUS = Russian  
 WORLD = Symbols see **World Symbol Key**, page 61.

**NOTE:** Language can be changed later.

### Units

Press **B** to enter settings and then **B** again to enter units. Select appropriate units of measure.

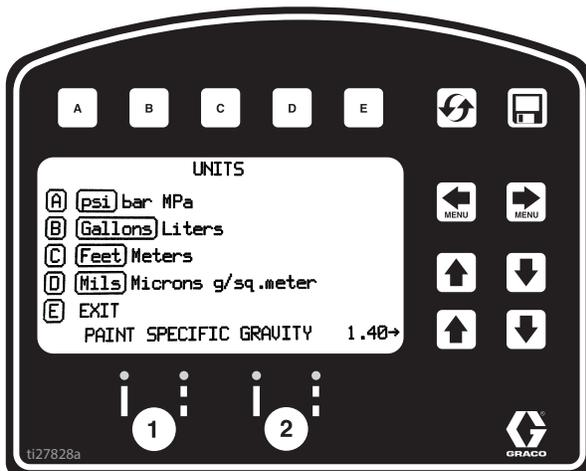

### US Units

Pressure = psi  
 Volume = gallons  
 Distance = feet  
 Line Thickness = mil

### SI Units

Pressure = bar (MPa available)  
 Volume = liters  
 Distance = meters  
 Line thickness = micron (g/m<sup>2</sup> available)

Paint Specific Gravity = Use UP and DOWN arrows to set specific gravity. Required to determine paint thickness.

**NOTE:** All units can be changed individually at any time.

### Calibration

1. Check rear tire pressure  $55 \pm 5$  psi ( $379 \pm 34$  kpa) and fill if necessary.
2. Extend steel tape to distance greater than 26 ft. (8m).

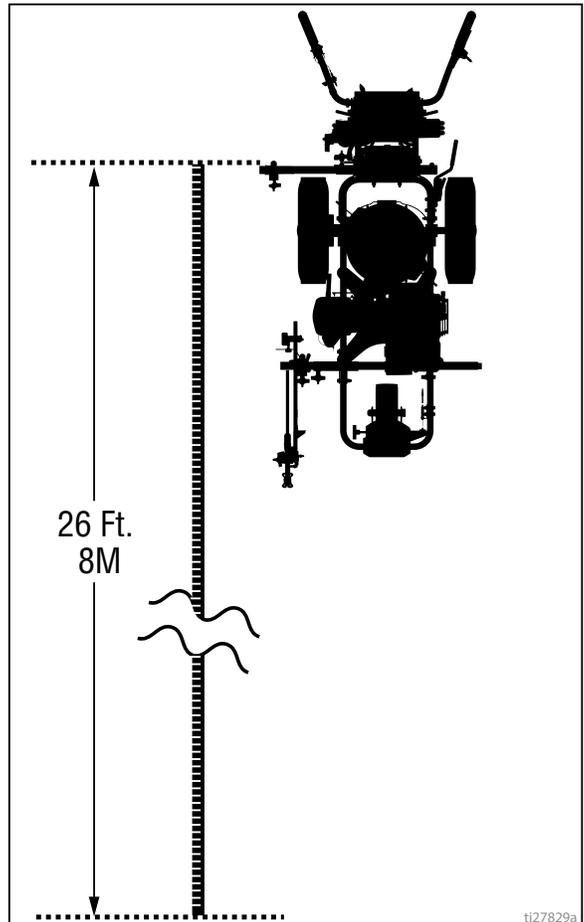

- Press to select Setup/Information.



- Press for Calibration. Set TRAVEL DIST to 25 ft (7.6m) or longer. Longer distances ensure better accuracy, depending on conditions.

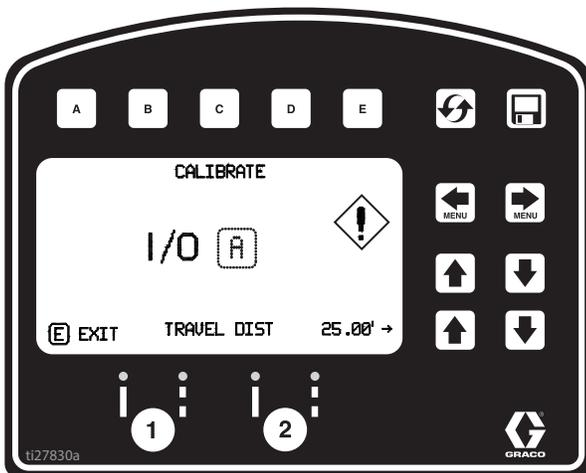

- Align part of the unit with 1 foot (30.5cm) on steel tape.

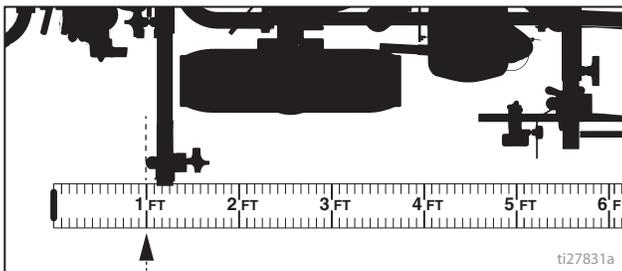

- Push to start calibration.

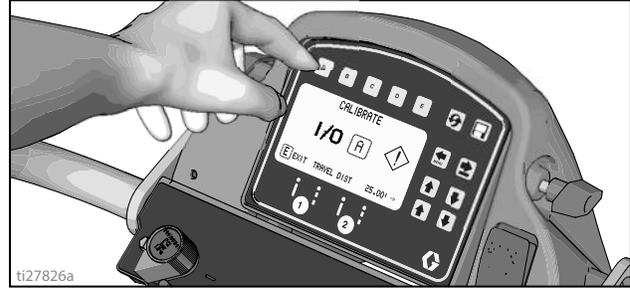

- Move striper forward. Keep unit aligned with steel tape.
- Stop when chosen part of unit aligns with 26-ft (8m), or distance entered, on steel tape (25-ft./ 7.6m distance).

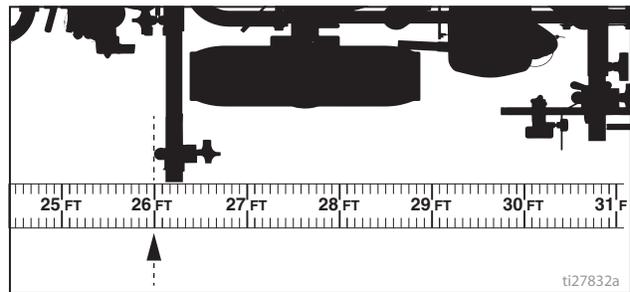

- Push to complete calibration.

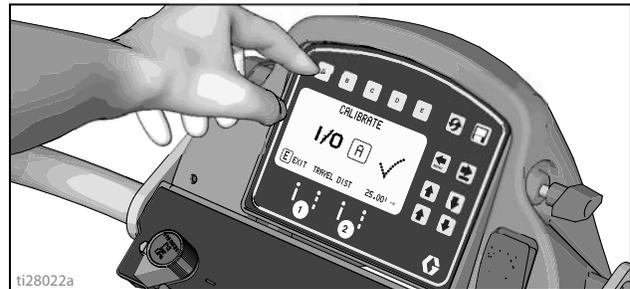

- Calibration is not complete when the exclamation mark symbol is displayed.
- Calibration is finished when the check mark symbol is displayed.

- Calibration is now complete.

Go to **Measure Mode (Standard Series)**, page 30, and verify accuracy by measuring the tape.

## Striping Mode (Standard Series)

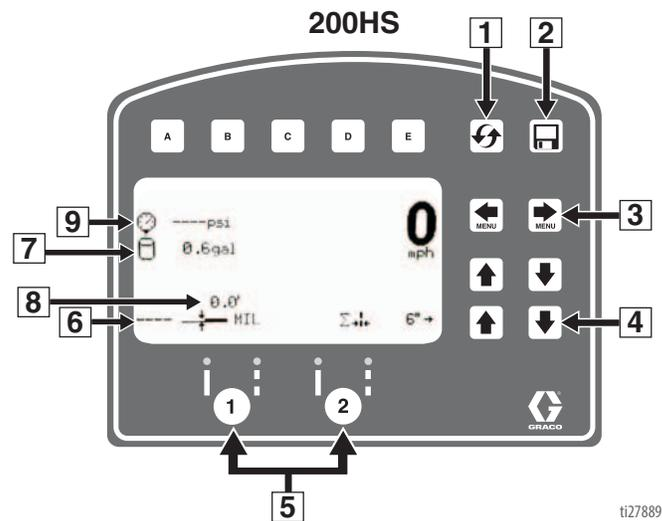
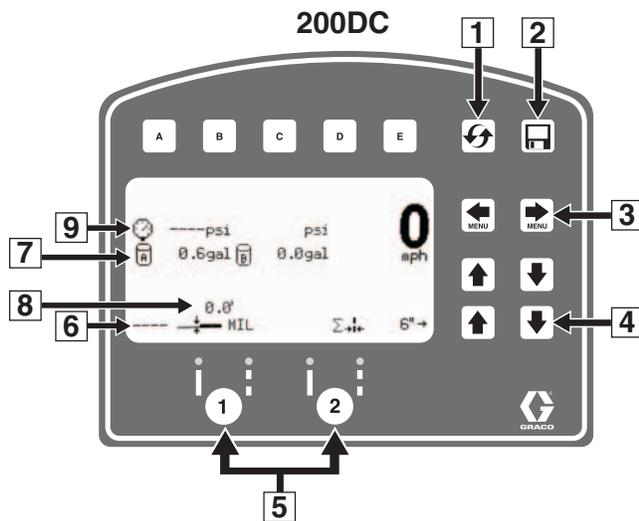

ti27889a

Ref.	Description
1	Resets Distance, Gallons, Miils
*2	Job logging
3	Scroll between menu screens
4	Line width adjustment buttons
*5	Auto gun buttons
6	MIL thickness. While spraying "Instant MIL avg" is displayed. When stopped total "Job MIL avg" is displayed.
7	Total gallons (liters) sprayed
8	Total line length sprayed.
9	Pressure

\*Not active in Standard Series. Upgrade to HP Auto Series, see pages 9 - 10.

### Operating in Striping Mode

1. Make sure engine is running.
2. Set pump switch to ON.

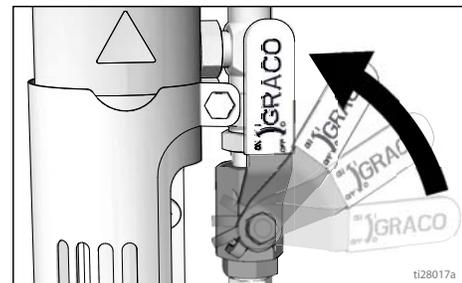

ti28017a

3. Pull trigger to spray.

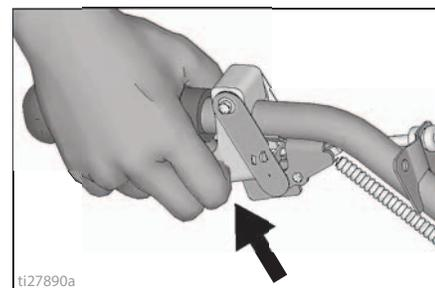

ti27890a

## Measure Mode (Standard Series)

Measure Mode replaces a tape measure to measure distances when laying out an area to be striped.

1. Use   to select Measure Mode.

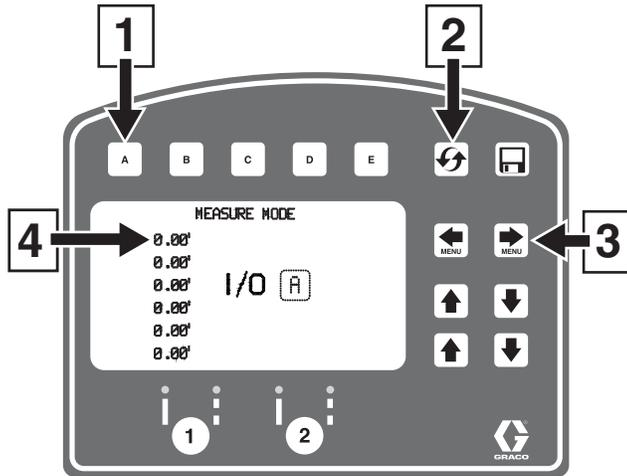

ti27834a

Ref.	Description
1	Press to start measurement, Press to stop measurement
2	Hold to reset values to zero
3	Scroll between main menu screens
4	Last measurement taken

2. Press and release . Move striper forwards or backwards. (Moving backwards is a negative distance.)

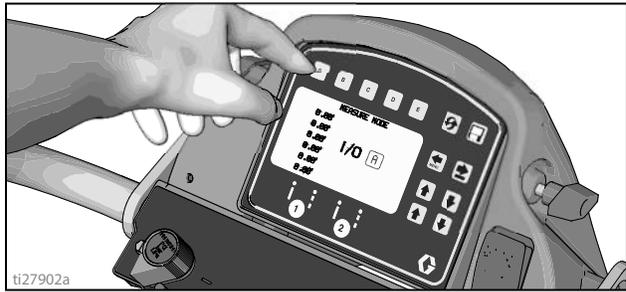

ti27902a

3. Press and release  to end measured length. Up to six lengths are viewable.

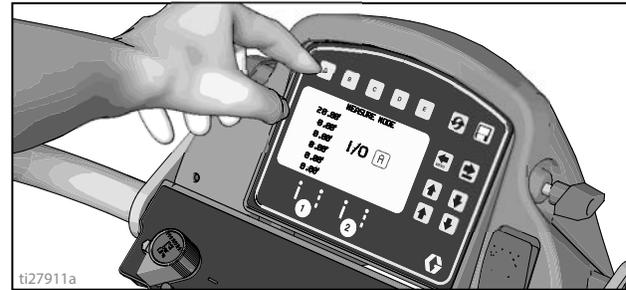

ti27911a

# Setup/Information

Use   to select Setup/Information.



Press **D** to select Language.  
See **Language**, page 27.

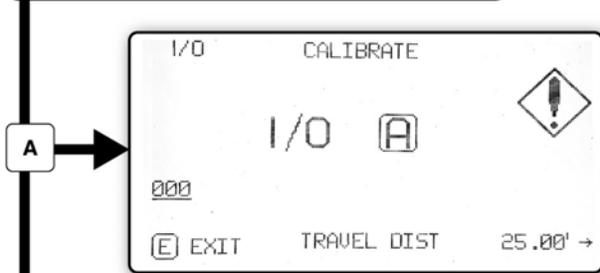

See **Calibration**, page 27.



See **Settings**, page 32.

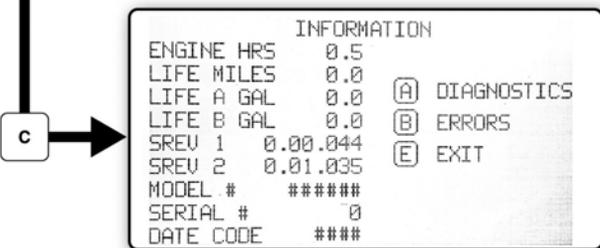

See **Information**, page 33.

t127835b

# Settings

Use   to select Setup/Information. Press  to open Settings Menu.

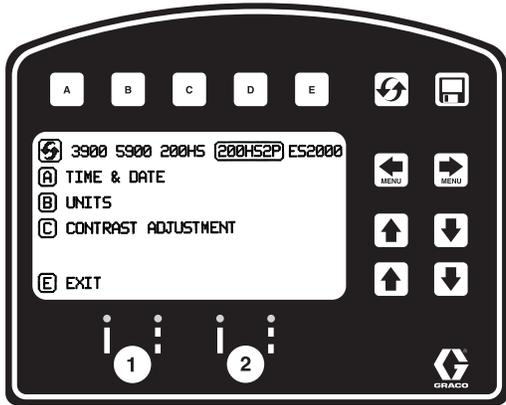

 Chooses the machine type. Necessary for accurate gallon counting.

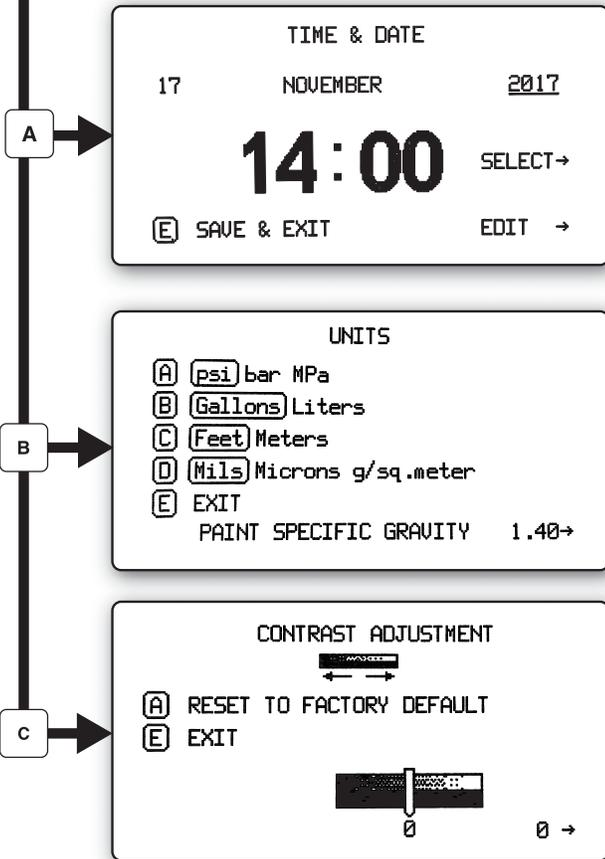

Use   to set time and date.  
 

Set units with    

Use   to adjust screen contrast to the desired value.

t127839b

# Information

Use to select Setup/Information. Press to open Information Menu.

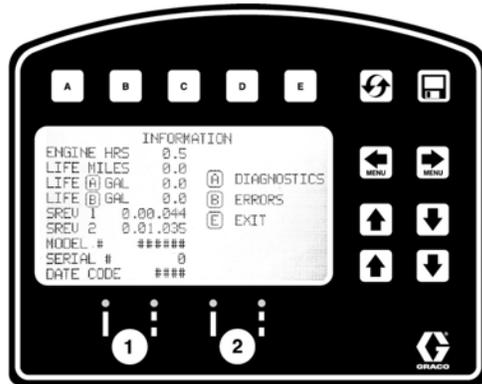

Displays and logs life data and striper information.

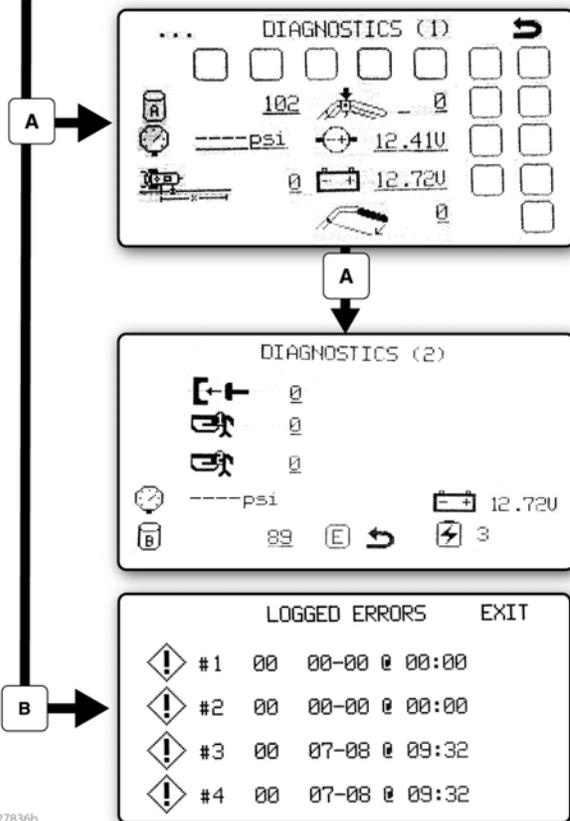

View and test functionality of components.

- Stroke Counter
- Touch Pad Buttons
- Pressure Transducer
- Engine Voltage
- Distance Sensor
- Battery Voltage

Logs last four error codes that occurred.

- Code Description
- 02 = Over pressure
- 03 = No transducer detected

Reset error codes

ti27836b

# HP Auto Series and HP Reflective Series

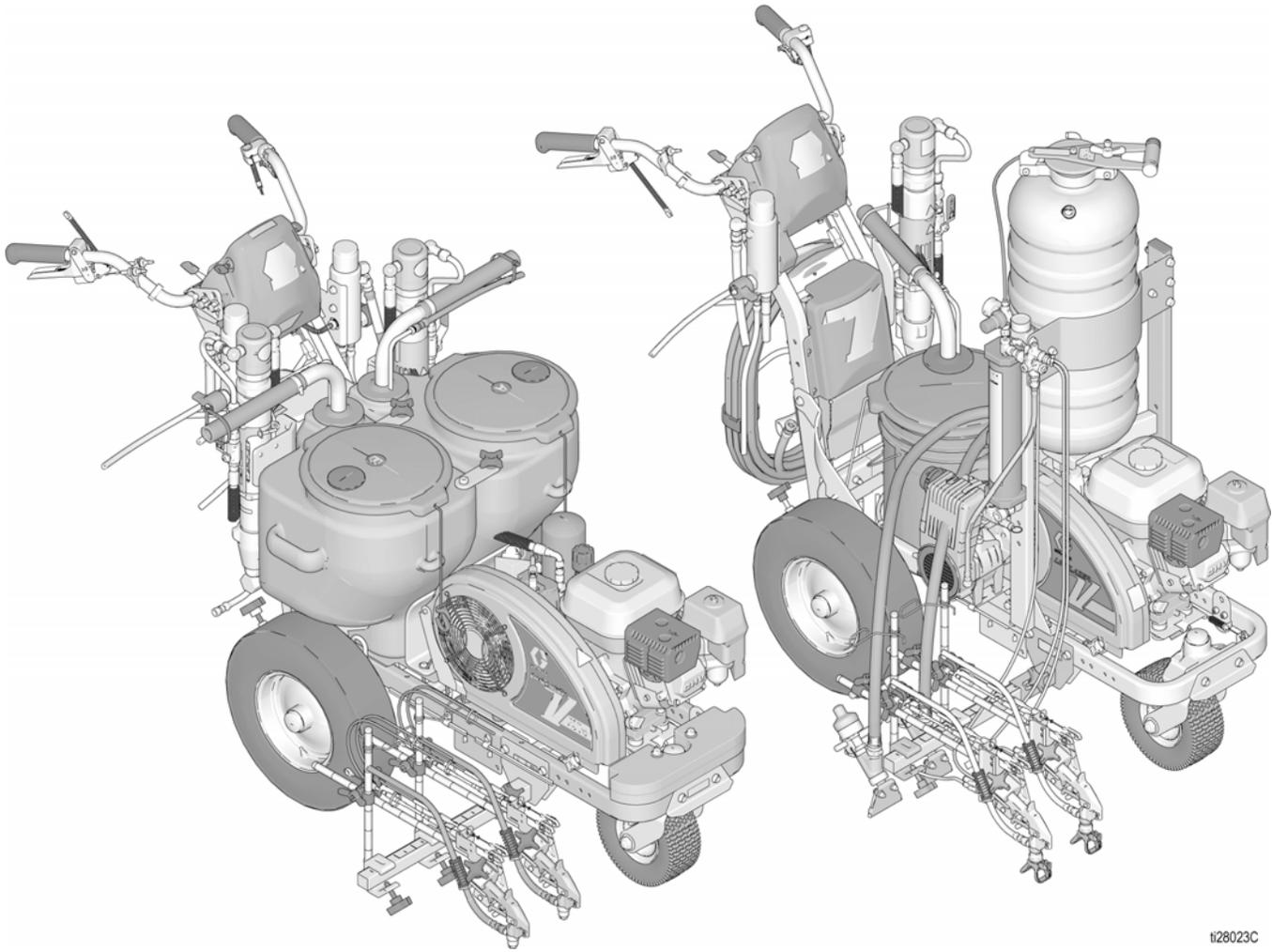

t28023C

# LineLazer V LiveLook Display

## HP Auto Series

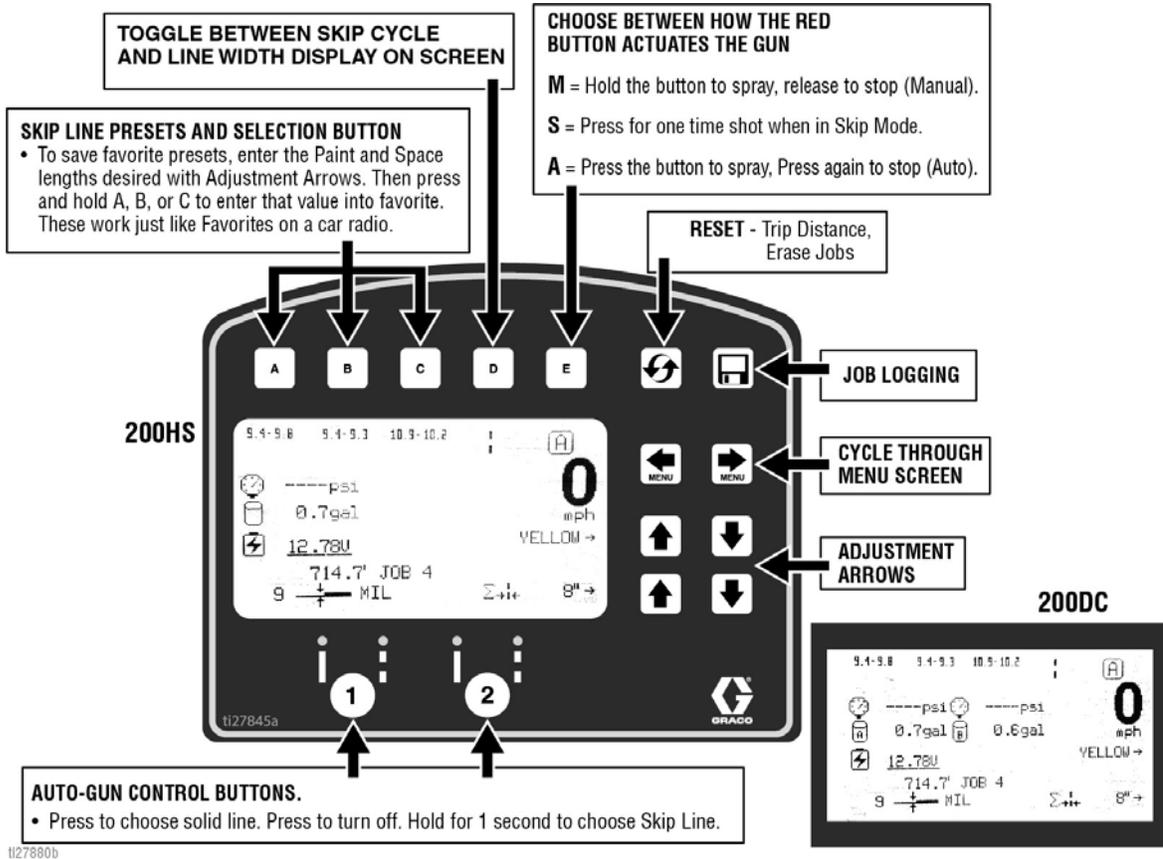

STRIPING SCREEN 200DC	MEASURE MODE	LAYOUT MODE	SETTING/INFO
<p>200HS</p>	<p>• <b>Measure Mode.</b> Ability to take up to 6 measurements by pressing the red button to start the measurement and pressing it again to end the measurement.</p> <p>• If an Auto Gun is selected (see below) and the red button is held down, a dot will be dropped every 12" until the red button is released.</p>	<p>• <b>Layout Mode.</b> Drop a dot at a chosen distance to layout a parking lot.</p> <p>• Enter stall size, active an auto gun, press the red button, and roll the machine. To stop dotting, press the red button again. Favorites can be saved just like in the main screen.</p> <p><b>A</b> STALL CALCULATOR see page 41</p> <p><b>B</b> ANGLE CALCULATOR see page 42</p>	<p>• Settings and Information can be accessed from this screen.</p> <p>• For accurate distance calculations the machine must be calibrated. Press A to calibrate the machine. Use a distance of at least 25' or more.</p>
<ul style="list-style-type: none"> <li>• <b>Main striping screen.</b> Must be in this mode to electronically actuate guns.</li> <li>• Automatic Skip Cycles can be laid from this screen. Choose skip line on the desired gun to fire. Enter the Paint and Space distance wanted and begin spraying.</li> <li>• Press the E Button to choose how the red button actuates the guns.</li> </ul> <p>M = Hold to spray, release to stop                      S = Press for one time shot when in Skip Mode.                      A = Press to start, press to stop</p>			

## Initial Setup (HP Auto Series)

The initial setup prepares the striper for operation based on a number of user entered parameters. Language selections and the units of measure selections can be set before you start or changed later.

### Language

From Setup/Information select appropriate language by pressing **D** until the language is outlined.



ENG = English  
 SPA = Spanish  
 FRE = French  
 DEU = German  
 RUS = Russian  
 WORLD = Symbols see **World Symbol Key**, page 61.

**NOTE:** Language can be changed later.

### Units

Press **B** to enter settings and then **B** again to enter units. Select appropriate units of measure.

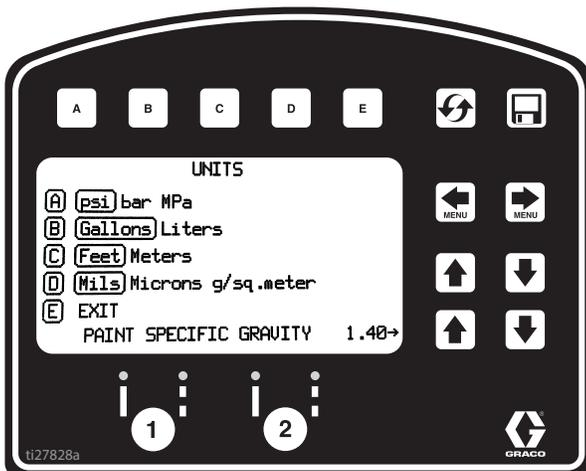

### US Units

Pressure = psi  
 Volume = gallons  
 Distance = feet  
 Line Thickness = mil

### SI Units

Pressure = bar (MPa available)  
 Volume = liters  
 Distance = meters  
 Line thickness = micron (g/m<sup>2</sup> available)

Paint Specific Gravity = Use UP and DOWN arrows to set specific gravity. Required to determine paint thickness.

**NOTE:** All units can be changed individually at any time.

### Calibration

1. Check rear tire pressure  $55 \pm 5$  psi ( $379 \pm 34$  kpa) and fill if necessary.
2. Extend steel tape to distance greater than 26 ft. (8m).

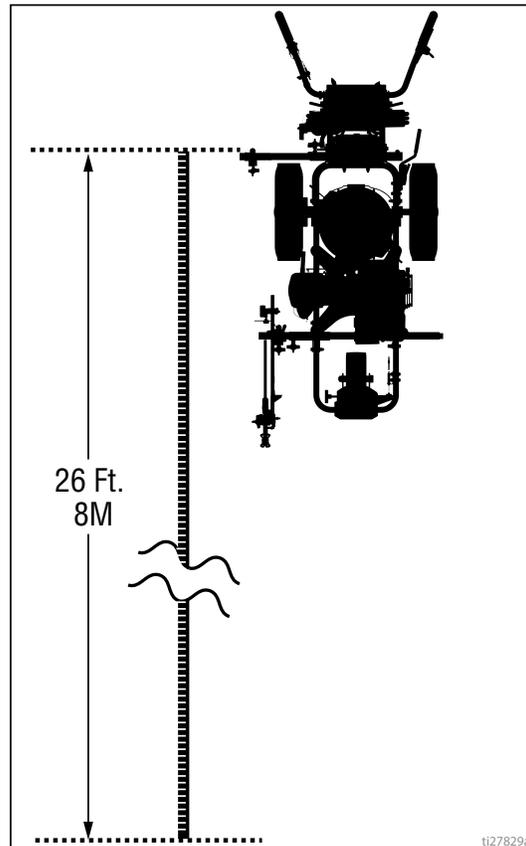

- Press   to select Setup/Information.

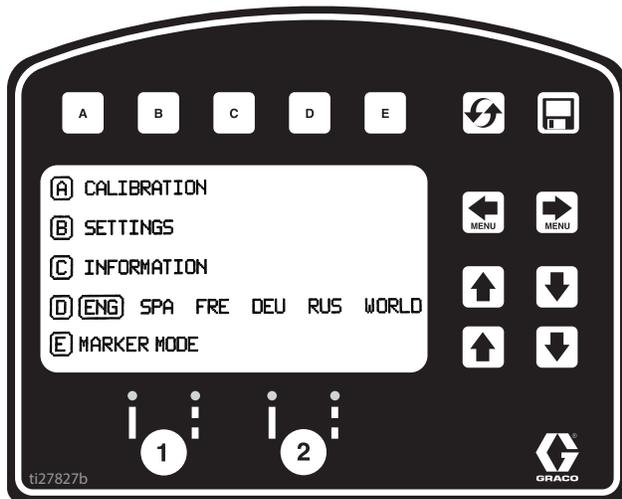

- Press **A** for Calibration. Set TRAVEL DIST to 25 ft (7.6m) or longer. Longer distances ensure better accuracy, depending on conditions.

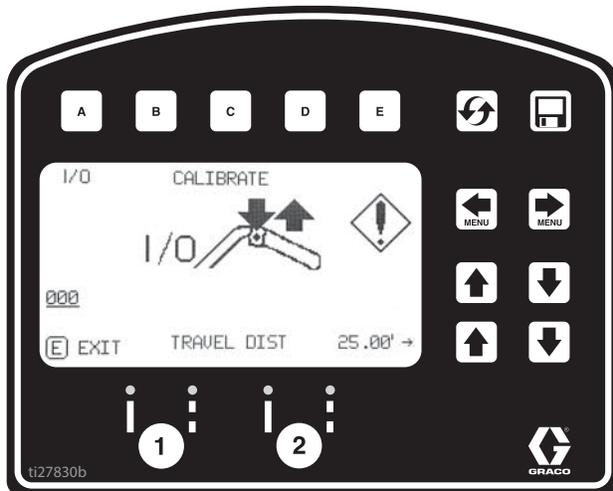

- Turn on laser and align laser dot with 1 foot (30.5cm) on steel tape.

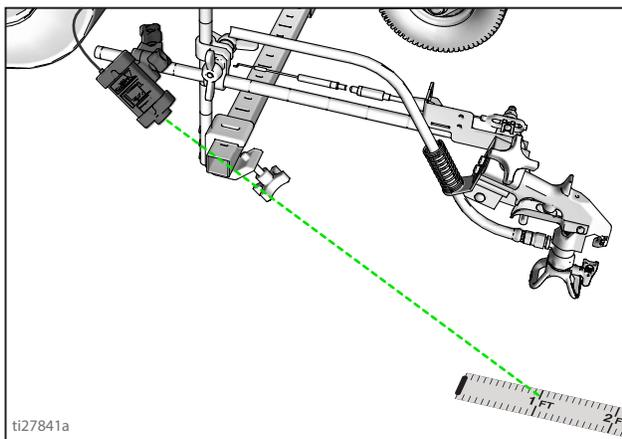

- Press and release auto gun trigger control to start calibration.

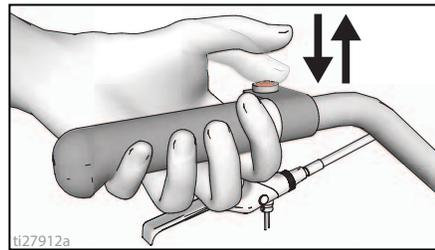

- Move striper forward. Keep laser dot on steel tape.
- Stop when laser aligns with 26-ft (8m) or distance entered on steel tape (25-ft./7.6m distance).

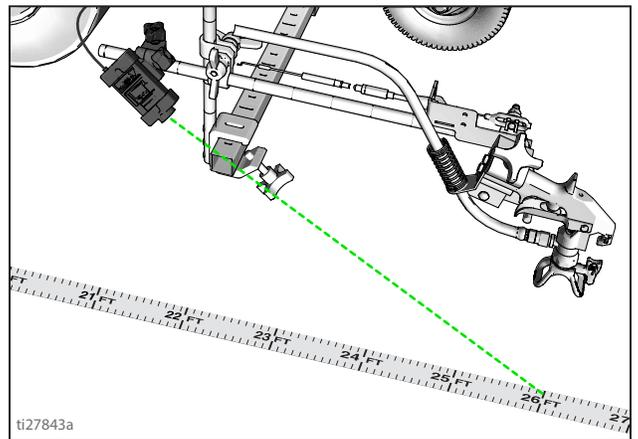

- Press and release auto gun trigger control to complete calibration.

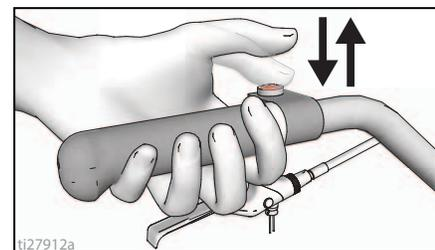

- Calibration is not complete when the exclamation symbol  is displayed.
- Calibration is finished when the check mark symbol  is displayed.

- Calibration is now complete.

Go to **Measure Mode (HP Auto Series)**, page 39, and verify accuracy by measuring the tape.

# Striping Mode (HP Auto Series)

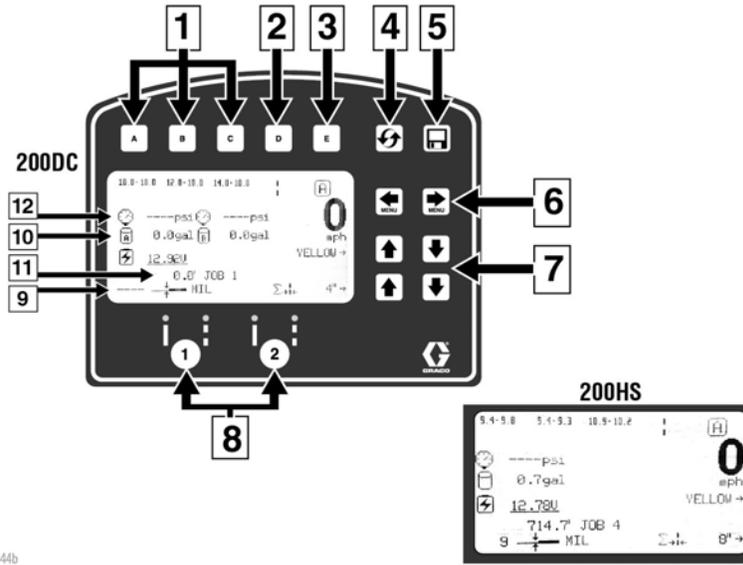

Ref.	Description
1	Select a "Favorite", press for less than one second.
	Save a "Favorite", press and hold for more than three seconds.
2	Cycles between viewing line width or paint and space value.
3	Cycles between Manual Mode, Semi-Automatic Mode, Automatic Mode.
	<b>Manual Mode</b> <b>M</b> : Press and hold gun trigger control to stripe.
	<b>Semi-Automatic Mode</b> <b>S</b> : Press and release gun trigger control to stripe the programmed length one time when in Skip Mode.
	<b>Automatic Mode</b> <b>A</b> : Press and release gun trigger control to start striping. Press and release button again to stop.
4	Resets trip distance.
5	Job Data Logger, page 48.
6	Scrolls between menu screens.
7	Paint and Space length <b>OR</b> line width adjustment buttons.
8	Auto guns activation buttons.
9	MIL thickness. While spraying "Instant MIL avg" is displayed. When stopped total "Job MIL avg" is displayed.
10	Total gallons (liters) sprayed.
11	Total line length sprayed.
12	Pressure

## Operating in Striping Mode

Striper must be running before activating gun trigger control.

1. Make sure engine is running.
2. Use gun activation buttons to select guns and line type.

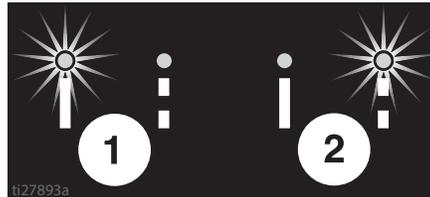

3. Press auto gun trigger control to begin spraying.

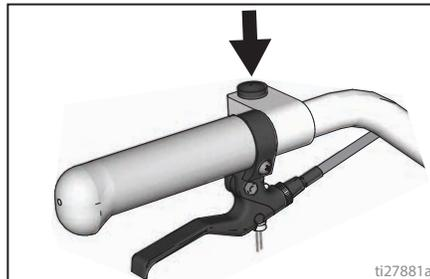

In Automatic Mode or Semi-Automatic Mode the **A** or **S** will flash when auto gun trigger control is pressed to signal mode is active.

## Measure Mode (HP Auto Series)

Measure Mode replaces a tape measure to measure distances when laying out an area to be striped.

1. Use   to select Measure Mode.

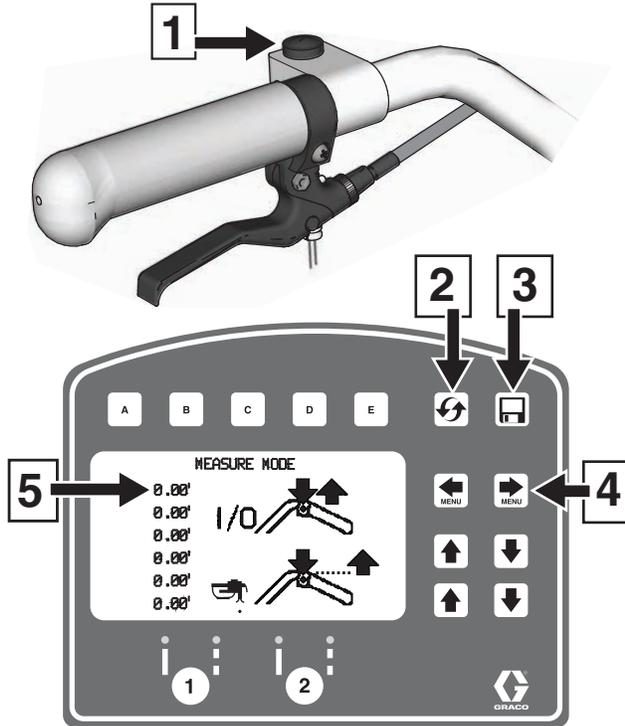

ti27914a

Ref.	Description
1	Press to start measurement, Press to stop measurement.
2	Hold to reset values to zero.
3	Job Data Logger, page 48.
4	Scroll between main menu screens
5	Last measurement taken

2. Press and release auto gun trigger control. Move striper forwards or backwards. (Moving backwards is a negative distance.)

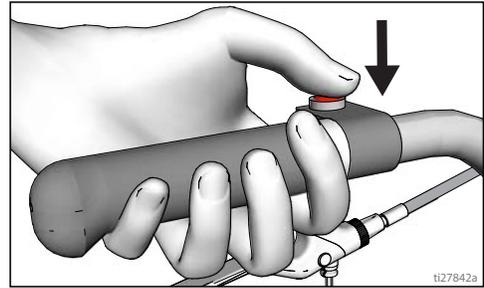

ti27842a

3. Press and release auto gun trigger control to end measured length. Up to six lengths are viewable.

The most recent measured length is also saved as the measured distance in the Stall Calculator display. See **Stall Calculator**, page 41.

If an auto gun is activated, press and hold gun trigger control at any time to apply a dot. If trigger is held while striper is moving, a dot is marked every 12-inches (30.5cm).

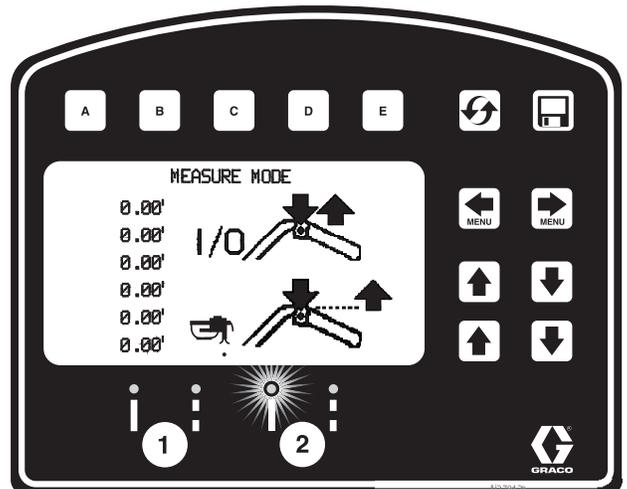

ti27915a

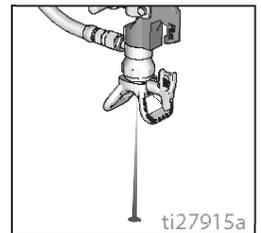
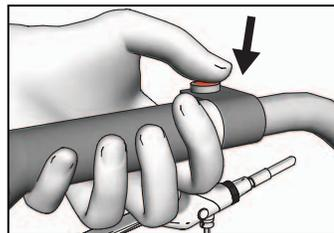

ti27915a

# Layout Mode

Layout Mode is used to calculate and mark parking lot stalls.

1. Use   to select Layout Mode.

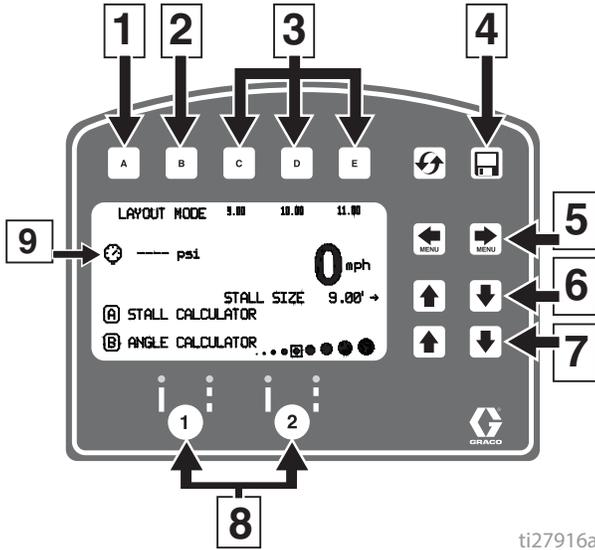

ti27916a

Ref.	Description
1	Opens Stall Calculator Menu. See <b>Stall Calculator</b> , page 41.
2	Opens Angle Calculator Menu. See <b>Angle Calculator</b> , page 42.
3	<b>Select</b> a "Favorite", press for less than one second.
	<b>Save</b> a "Favorite", press and hold for more than three seconds.
4	Job Data Logging, page 48.
5	Scroll between menu screens.
6	Adjust stall size/dot spacing.
7	Adjust dot size.
8	Auto Gun activation buttons.
9	Pressure.

2. Use gun activation buttons to select guns.

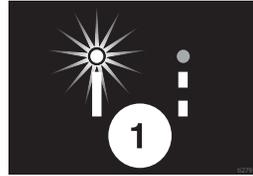

3. Press and release auto gun trigger control and move striper forward.

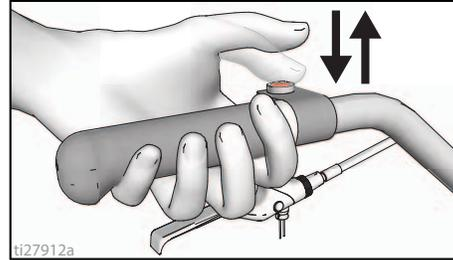

ti27912a

4. Striper default is to place a dot every 9.0 ft (2.7m) to mark the stall size. Stall size is adjustable.
5. Dots are laid down until gun trigger control is pressed and released again.

An indicator on the screen alternately flash when gun trigger control is pressed to signal mode is active.

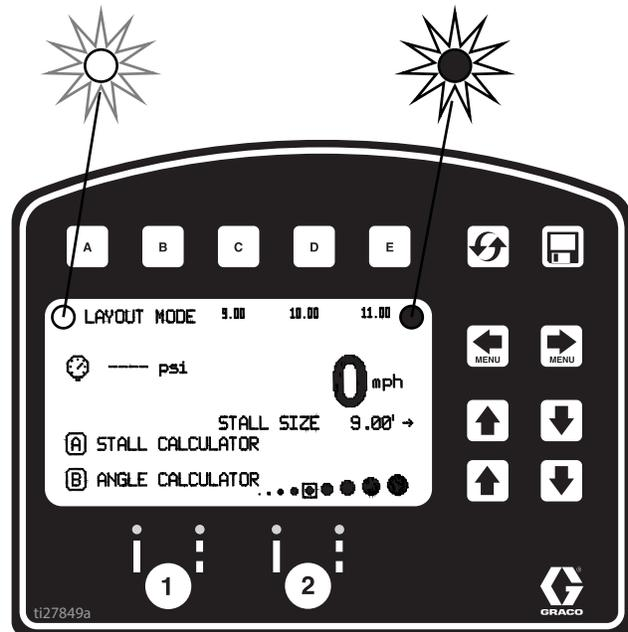

ti27849a

# Stall Calculator

Stall Calculator is used to set the stall size. The striper divides the measured length by the stall size to determine the number of stalls that will fit in the length measured. User can adjust number of stalls to a round number and stall width is calculated.

1. Use to select Layout Mode. Press to open Stall Calculator Menu.

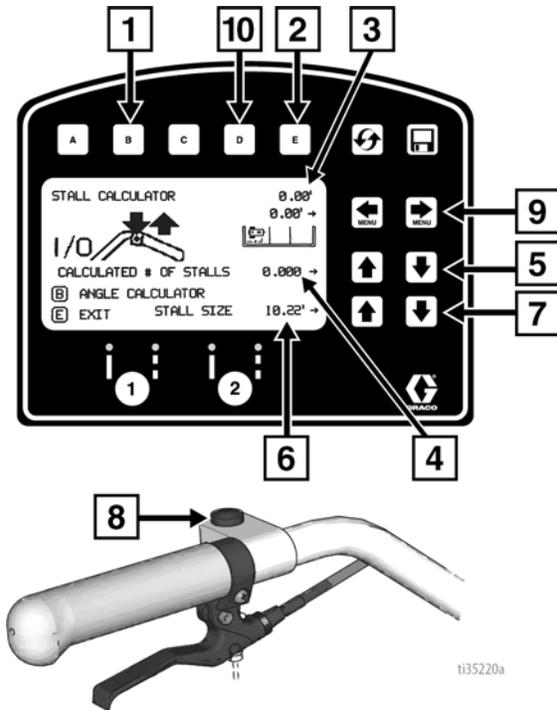

Ref.	Description
1	Opens Angle Calculator Menu. See <b>Angle Calculator</b> , page 42.
2	Exits and returns stall size to Layout Mode.
3	Measured distance.
4	Calculated # of stalls. Changing the number of stalls will change the stall size.
5	Adjusts number of stalls.
6	Stall size. Changing stall size changes the calculated # of stalls.
7	Adjusts stall size.
8	Press to start measurement, Press to stop measurement.
9	Adjusts Offset (x)
10	Stores Offset (x). Hold for 2 seconds to store value.

2. The most recent length measured in Measure Mode is automatically displayed. Press gun trigger control

to start a new measurement. Press again to stop measuring.

When measuring between curbs, the distance from the back tire/curb to the gun/laser dot, can be accounted for by setting the Offset (x) value.

- Back the striper up to the curb, then use a tape measure to measure from where the tire touches the curb to the laser dot on the ground.
- Use to enter the offset (x) value.
- This value can be stored by holding for 2 seconds.
- The value stored under can be added to the measured distance before or after the measurement is taken between the curbs.
- The offset (x) value can also be adjusted before or after the measurement is taken by using .

Stall size and calculated number of stalls are both adjustable.

3. Press to return to Layout Mode. The Stall size is saved and displayed on the Layout Mode screen.

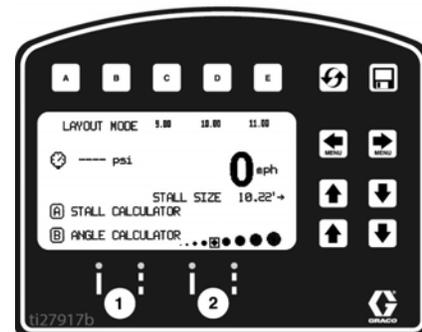
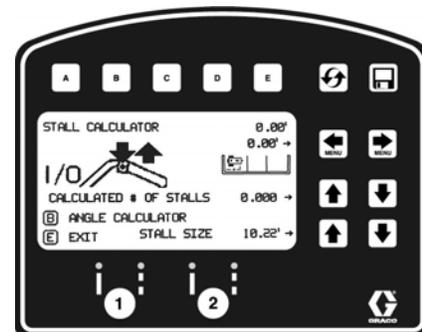

4. Press and release gun trigger control to start marking dots. Press and release gun trigger control again to stop.

## Angle Calculator

Angle Calculator is used to determine the offset value and dot spacing value for a layout.

- Use to select Layout Mode. Press **B** to open Angle Calculator Menu.

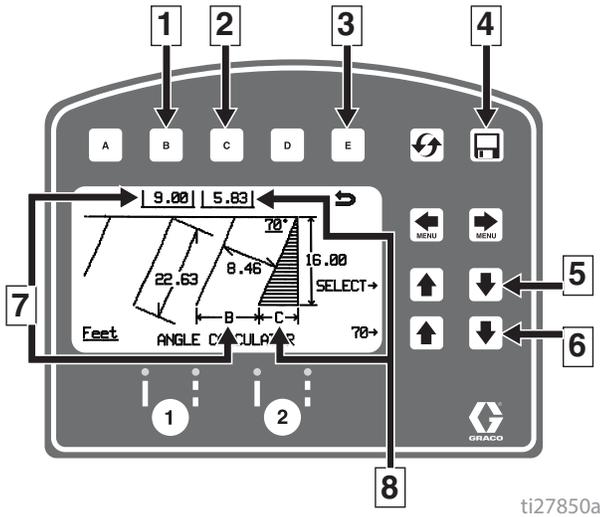

ti27850a

Ref.	Description
1	Transfers calculated dot spacing, B, to Layout Mode.
2	Transfers calculated off set, C, to Layout Mode.
3	Exits and returns to Layout Mode without transferring any values.
4	Data Logging.
5	Select input variables.
6	Adjust the variable selected.
7	Calculated dot spacing, B.
8	Calculated off set, C.

- Dot spacing (B) and offset (C) are calculated based on the parameters entered:

Stall angle  
 Stall depth  
 Stall size (width)  
 Line Length

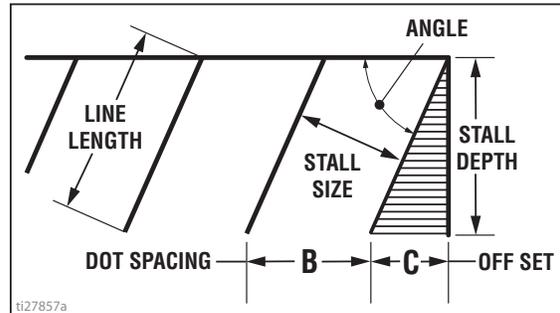

- Press **C** to transfer calculated off set distance to Layout Mode. Save this value in favorites if desired.

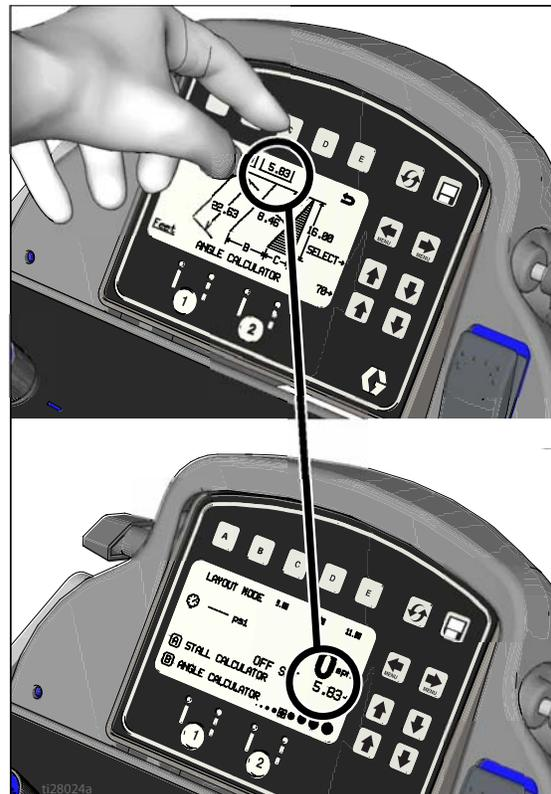

ti28024a

4. Press **B** to transfer calculated dot spacing distance to Layout Mode. Save this value in favorites if desired.

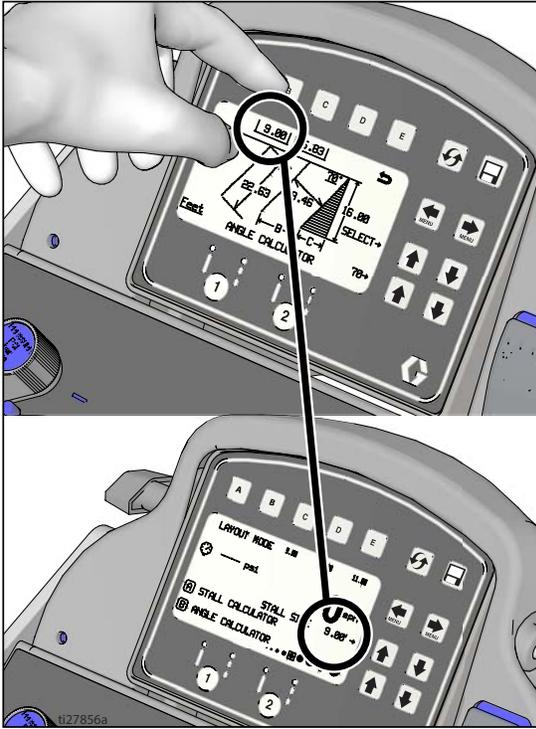

5. Press and release auto gun trigger control to start marking stall size dots. Press and release gun trigger control to stop marking.

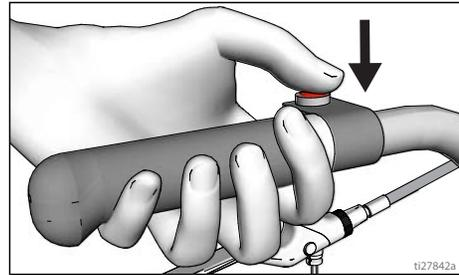

## Setup/Information

Use   to select Setup/Information.



Press **D** to select Language.  
See **Language**, page 36.

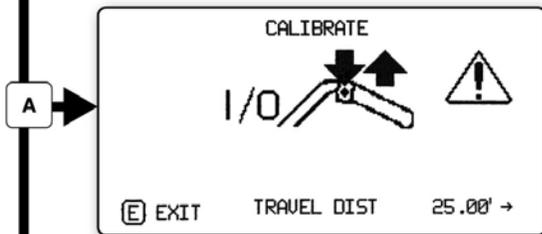

See **Calibration**, page 36.

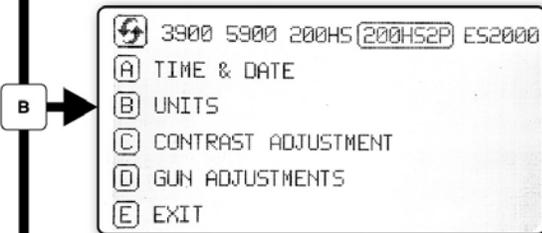

See **Settings**, page 45.

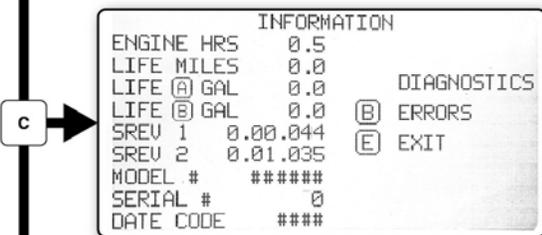

See **Information**, page 46.

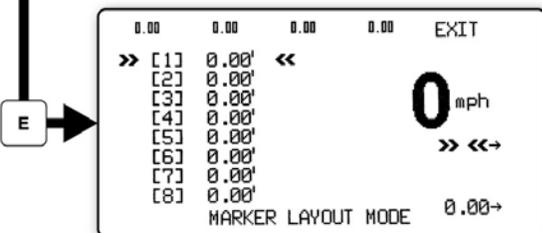

See **Marker Layout Mode**, page 47.

ti27858b

# Settings

Use to select Setup/Information. Press to open Settings Menu.

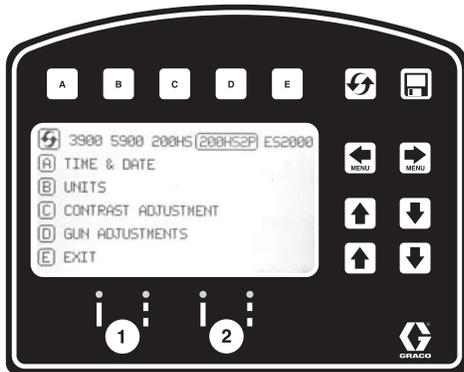

Chooses the machine type. Necessary for accurate gallon counting.

Use to set time and date. Needed for accurate Data Logging.

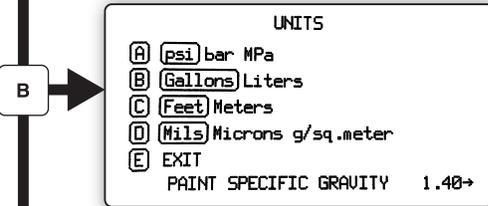

Set units with



Use to adjust screen contrast to the desired value.

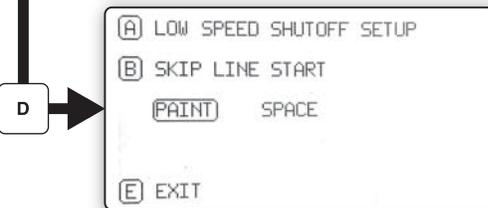

For programmed skip lines, press to choose: **Paint first** or **Space first**

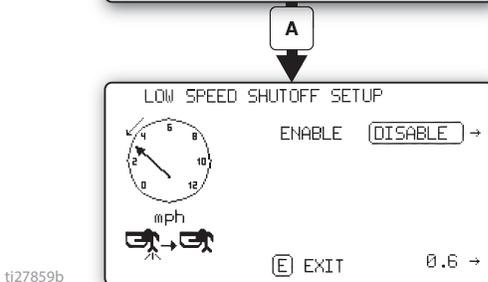
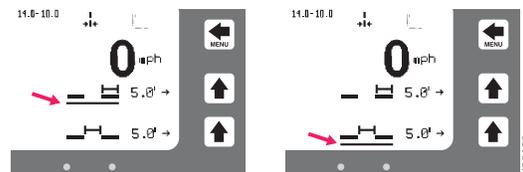

In Auto-mode, guns won't fire or will shut off if speed is below set value.

Enable or Disable Low Speed Shutoff

Adjust low speed setting.

ti27859b

ti28158a

# Information

Use to select Setup/Information. Press to open Information Menu.

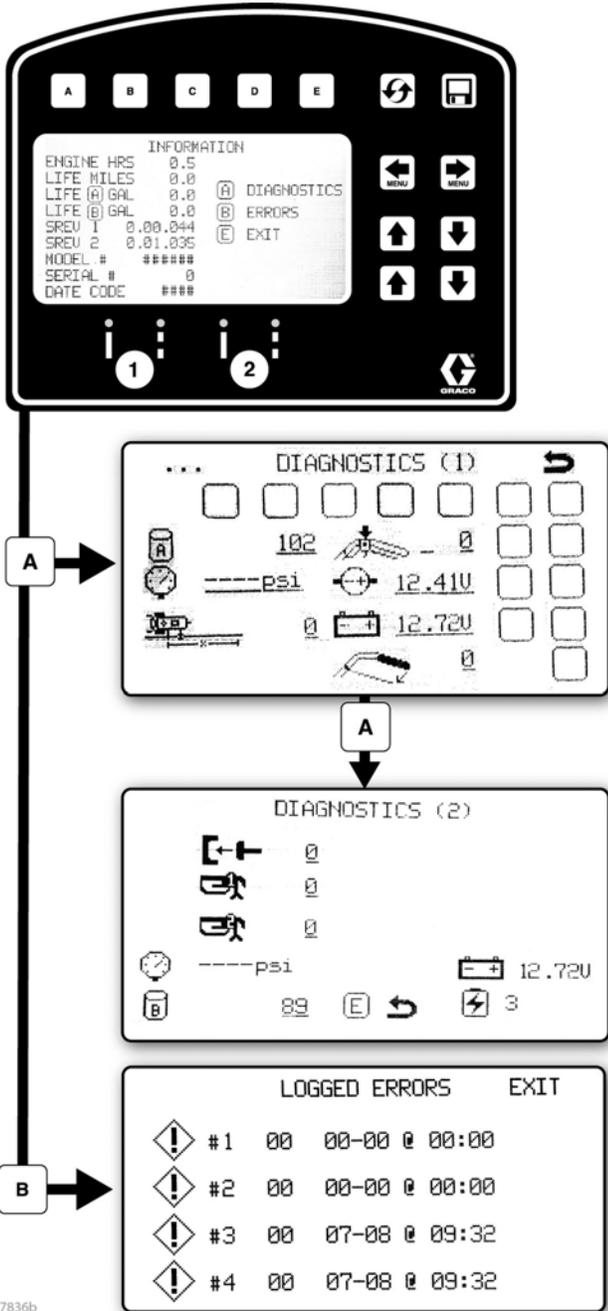

Displays and logs life data and striper information.

View and test functionality of component

- Stroke Counter
- Pressure Transducer
- Distance Sensor
- Touch Pad Buttons
- Engine Voltage
- Battery Voltage

- Clutch
- Solenoid 1
- Solenoid 2
- Battery charger state

Logs last four error codes that occurred.

- Code Description
- 02 = Over pressure
- 03 = No transducer detected

- Reset error codes

t127836b

## Marker Layout Mode

The Marker Layout Mode feature sprays a dot or a series of dots to mark an area.

1. Use   to select Setup/Information. Press  to open Marker Layout Mode.

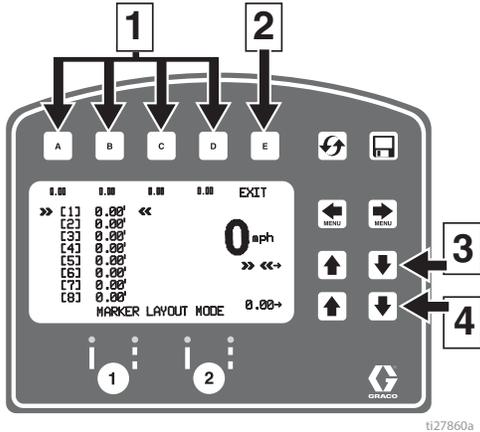

Ref.	Description
1	Select a "Favorite", press for less than one second.
	Save a "Favorite", press and hold for more than three seconds.
2	Exits and returns to Information Menu.
3	Select value to change.
4	Adjust spacing value.

2. Use arrow keys to set up a marker pattern.
3. Marker layout example shows a typical lane layout for reflective markers. Set space sizes up to eight consecutive measurements. By leaving zeros in any space, Marker Layout Mode will skip to the next measurement in a continuous loop.

Some other uses of Marker Layout Mode are:

- Multiple spaced handicap stall layout
- Double line stalls

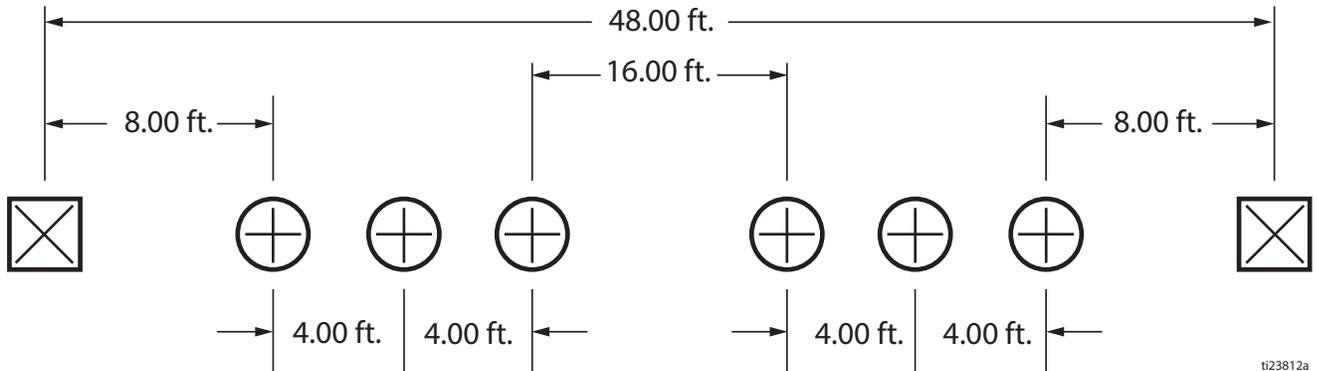

4. Set gun switch to skip line or solid line.

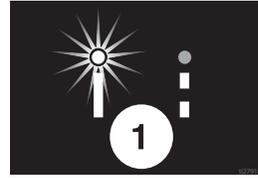

5. Press and release auto gun trigger control to start marking dots. Press and release auto gun trigger control again to stop.

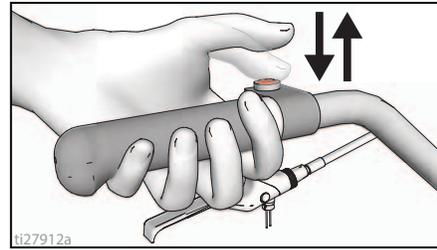

An indicator before and after Marker Mode on the screen alternately flash when gun trigger control is pressed to signal mode is active.

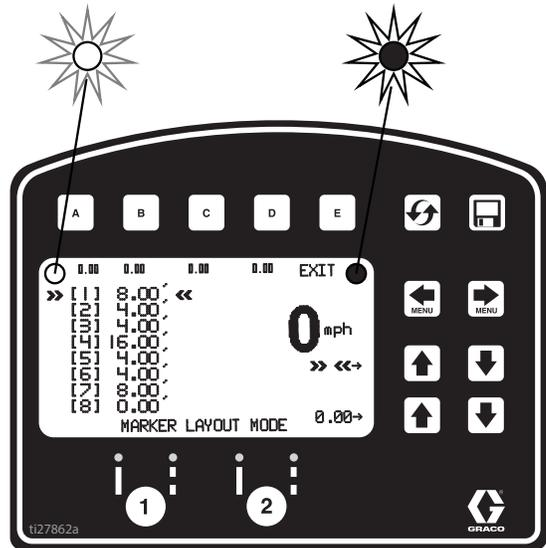

## Data Logging

The LLV control is equipped with Data Logging, which allows the user to recall job data and export the data from the machine to a USB drive.

1. Press the  to open the Data Logging pop up window.
2. Choose to start recording a new job or view jobs previously done.

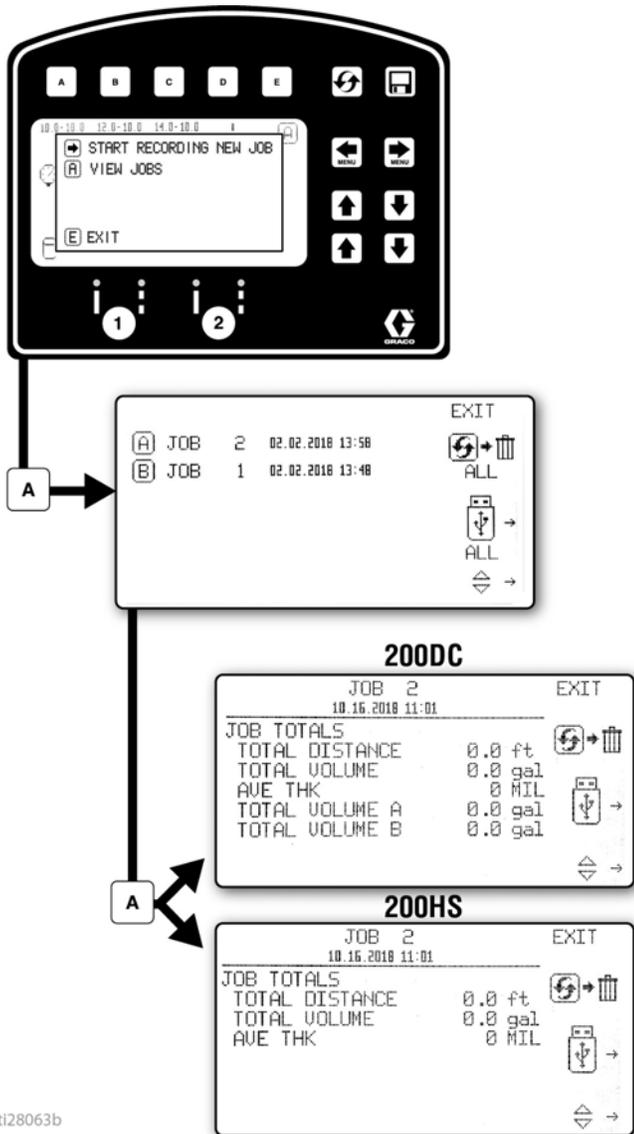

 Start recording a new job.

 Erase all jobs

 Export all jobs to USB

 Erase jobs

 Export job to USB

Job data is compiled while spraying. A summary of volume sprayed, distance sprayed and average mil thickness is displayed for the entire job. The job is also broken down by colors, line widths and stencil volume sprayed.

ti28063b