

Repair Kits for Magnum ProX & GX Sprayers

3A3951D

EN

Use these instructions when repairing the ProX or GX sprayers.



IMPORTANT SAFETY INSTRUCTIONS

Read all warnings and instructions in the repair kit instructions and in the Owners/Operation manual for the sprayer.

Contents

Section	Description	Kit #
1 Drive	Front Cover Replacement page 3	17J866
	Motor Replacement page 4	17F756, 17F757, 17F758, 17K285, 17K684, 17L083
	Fan Replacement page 4	16X980, 287770
	Gear & Yoke Replacement page 5	17J863, 17J864, 17J869
2 Control	Control Board Replacement page 7	17J867, 17J885
3 Pump	Pressure Control Replacement page 9	17J881, 17J927
	Prime/Spray Valve and Knob Replacement page 10	17J925
	Pump Outlet Valve Replacement page 11	17J880
	Pump Inlet Valve Replacement page 12	17J876, 17J877, 17J924
	PushPrime Button Replacement page 12	17J878

Refer to the illustrations in this document and your Owners/Operation manual for additional parts information, wiring diagrams, and any additional assembly torques that you may need.

Pressure Relief Procedure

Before servicing the sprayer, pump pressure must be relieved.

WARNING

SKIN INJECTION HAZARD: This sprayer builds up an internal pressure of 3000 psi (20.7 MPa, 207 bar) during use. This equipment stays pressurized until pressure is manually relieved. Follow this **Pressure Relief Procedure** whenever you stop spraying and before cleaning, checking, servicing, or transporting equipment to prevent serious injury.

1. Turn ON/OFF switch to the **OFF** position.
2. Engage the trigger lock. Always engage the trigger lock when sprayer is stopped to prevent the gun from being triggered accidentally.

3. Turn pressure control to lowest setting.
4. Put drain tube into a pail and place Prime/Spray valve in PRIME position (drain) to relieve pressure.
5. Hold the gun firmly to a pail. Point gun into pail. Disengage the trigger lock and trigger the gun to relieve pressure.
6. Engage the trigger lock.
7. If you suspect the spray tip or hose is clogged or that pressure has not been fully relieved:
 - a. **VERY SLOWLY** loosen the spray tip guard retaining nut or the hose end coupling to relieve pressure gradually.
 - b. Loosen the nut or coupling completely.
 - c. Clear airless hose or spray tip obstruction.

CALIFORNIA PROPOSITION 65

This product contains a chemical known to the State of California to cause cancer, birth defects or other reproductive harm. Wash hands after handling.

Drive

Drive Assembly Drawing

Ref.	Torque
△1	140-160 in-lb (16 - 18 N•m)
△2	30-35 in-lb (3.5 - 4.0 N•m)
△3	110-120 in-lb (12 - 14 N•m)

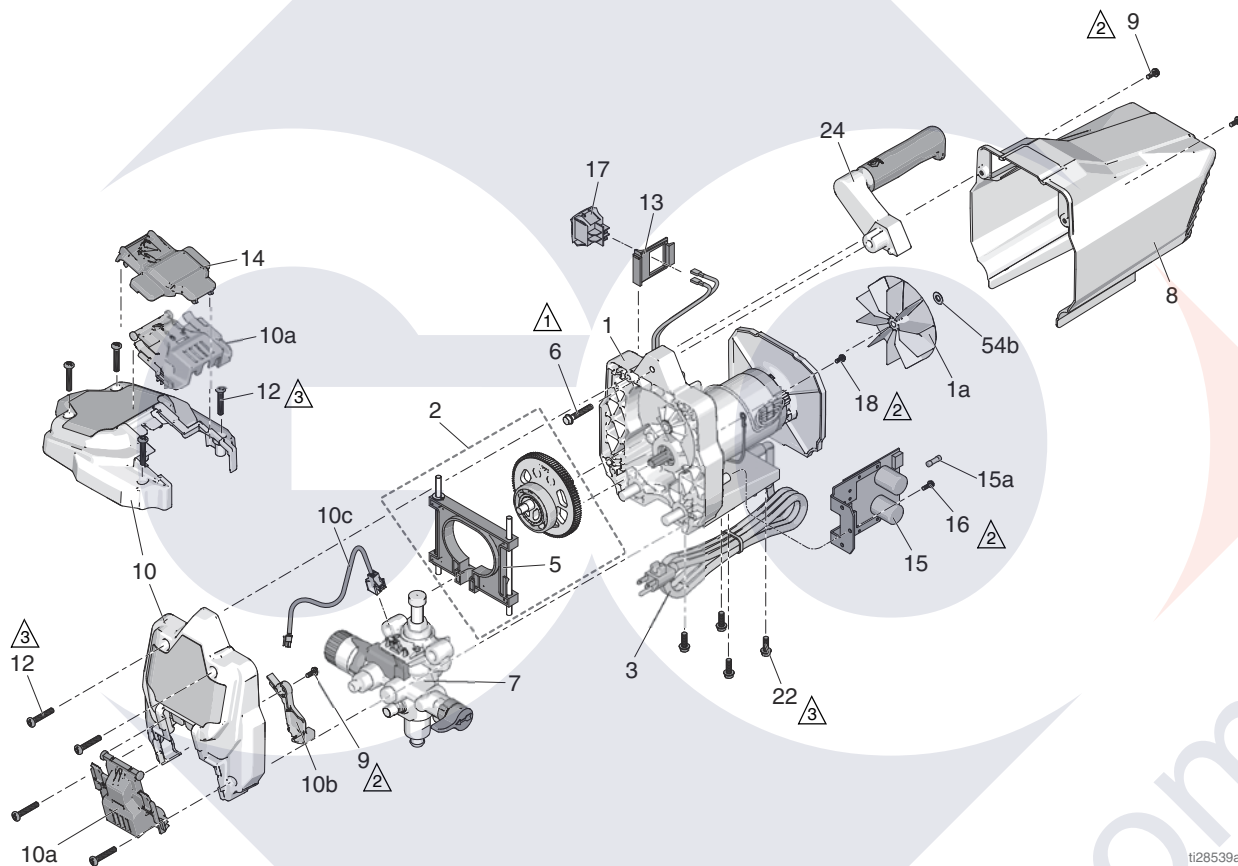

Ref. Description

- 1 Motor
- 1a Fan
- 2 Gear and yoke
- 3 Power cord
- 5 Yoke
- 6 Handle screw
- 7 Pump
- 8 Motor shield
- 9 Machine screw 10-24 x 0.5 in.
- 10 Front cover
- 10a Easy access cover

Ref. Description

- 10b Wire cover
- 10c Cable
- 12 Machine screw (T-30 Torx)
- 13 Switch bracket
- 14 Paint shield (DI models only)
- 15 Control
- 15a Fuse, 12.5A slow blow
- 16 Screw
- 17 ON/OFF switch
- 18 Machine screw
- 22 Screw, thread forming
- 24 Handle, stand models

ti28539a

Front Cover Replacement

See **Drive Assembly Drawing** page 2 and your Owners/Operation manual for illustrations.

Disassembly

1. Perform **Pressure Relief Procedure**, on page 1.
2. Unplug sprayer.

Remove Motor Shield

3. Remove two machine screws (9) and motor shield (8).

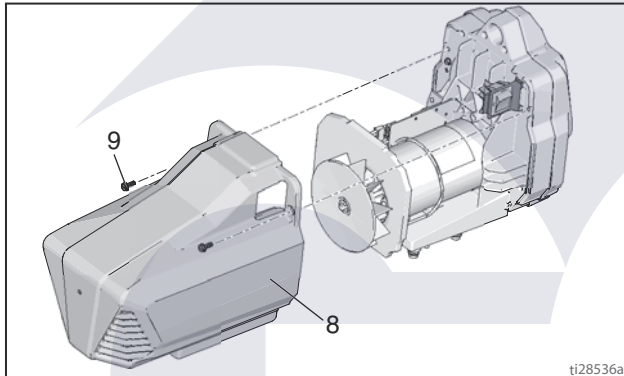

4. Disconnect cable (10c) from control board (15).

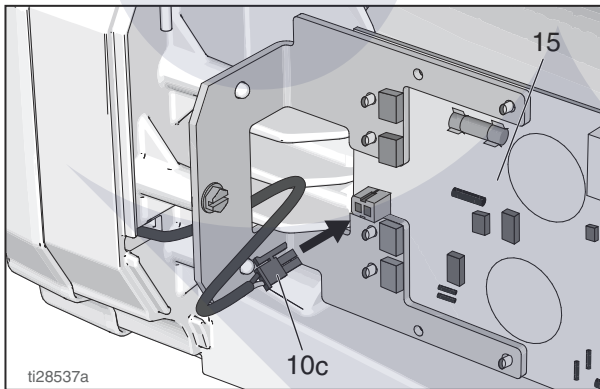

5. If necessary remove paint shield (14). Paint shield is not included on all sprayers.
6. Position sprayer so front cover (10) is pointing up.
7. **Open Easy Access Door** page 9.
8. Remove four front cover (10) screws (12) using a T-30 Torx. Make certain gear and yoke (2) remain installed in drive housing.

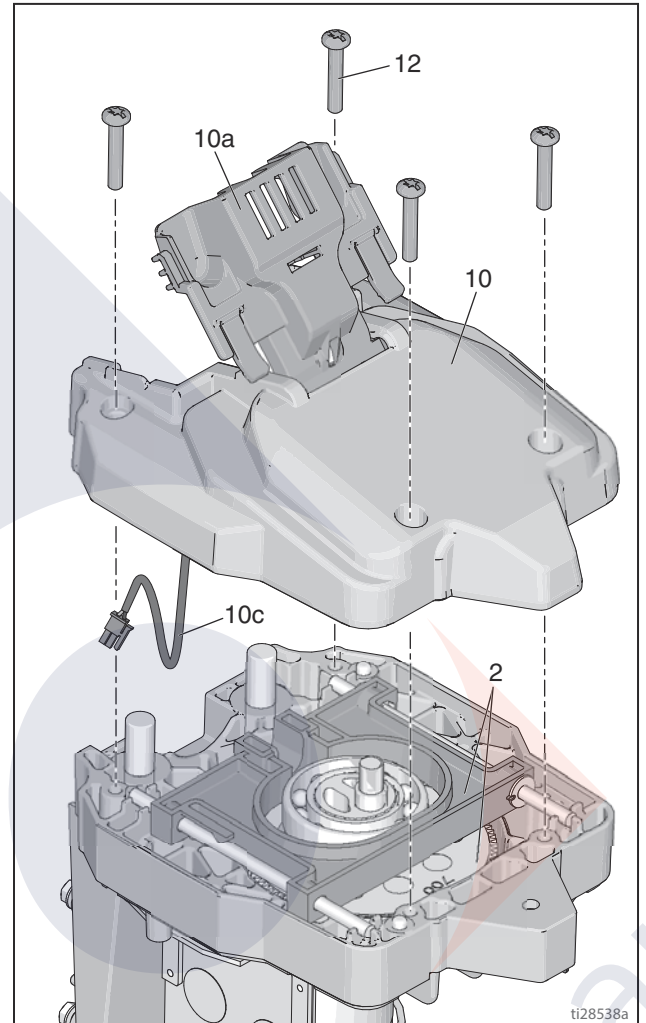

9. Pull cable (10c) through drive housing.

Assembly

1. Locate new front cover (10).
2. Route cable (10c) through drive housing to control board (15).
3. Assemble front cover (10) to drive housing. Insert four screws (12) and torque. See **Drive Assembly Drawing** page 2 for torque.
4. Connect cable (10c) to control board (15).

Install Motor Shield

5. Install motor shield (8) using two screws (9) removed earlier. Make sure motor shield (8) slides into switch bracket (13). Be careful not to pinch the cable (10c) when installing the motor shield (8).
6. **Close Easy Access Door** page 10.

Motor Replacement

See **Drive Assembly Drawing** page 2 and your Owners/Operation manual for illustrations.

NOTE: On hopper units you may need to remove the hopper before replacing the motor. Direct immersion and hopper units are easier to disassemble if the sprayer is placed on the side. Save all hardware removed during disassembly, most is required during reassembly.

Removal

1. Perform **Pressure Relief Procedure**, on page 1.
2. Unplug sprayer.
3. Remove pump assembly see Steps 3 – 5 in **Pressure Control Replacement** page 9 disassembly procedure.
4. Remove front cover see **Front Cover Replacement** page 3 disassembly procedure.
5. Disconnect leads from ON/OFF switch (17) and slide switch bracket (13) with ON/OFF switch (17) out of the drive housing (1).
6. Disconnect all leads from control board (15) and remove control board. See **Control Board Replacement** page 7.
7. Remove gear and yoke (2). See **Gear & Yoke Replacement** page 5.
8. Remove ground screw (18) and power cord (3) from motor drive housing (1).
9. For sprayers with a handle (24), remove screw (6) and handle (24) from drive housing (1).
10. Remove four screws (22) and motor (1) with drive housing from sprayer frame.

Installation

1. Secure new motor (1) with drive housing to frame using four screws (22) and torque. See **Drive Assembly Drawing** page 2 for torque.
2. For sprayers with a handle (24), install screw (6) and handle (24) into drive housing (1).
3. Install power cord (3) in drive housing (1), route power cord (3) through the hole located in the bottom of the drive housing (1) and around the top of the motor shell.
4. Reconnect ground wire from power cord (3) with screw (18) to motor drive housing (1) and torque. See **Drive Assembly Drawing** page 2 for torque.
5. Slide switch bracket (13) with switch (17) into drive housing (1).
6. Install control board (15), reconnect all wire leads and motor connector. See **Control Board Replacement** page 7. Refer to wiring diagram in your Owners/Operation manual.

7. Install gear and yoke (2). See **Gear & Yoke Replacement** page 5.
8. Install front cover see **Front Cover Replacement** page 3 assembly procedure.
9. Install pump assembly see Steps 7 – 9 in **Pressure Control Replacement** page 9 assembly procedure.

Fan Replacement

There are two fans used on this series of sprayers. One is a direct drive fan (see Step 4 for replacement procedure) the other is a clutch fan (see Step 5 for replacement procedure).

1. Perform **Pressure Relief Procedure**, on page 1.
2. Unplug sprayer.
3. **Remove Motor Shield** page 3.
4. Direct drive fan replacement
 - a. Pry push nut (54b) off the motor shaft with a small screwdriver. Discard old push nut

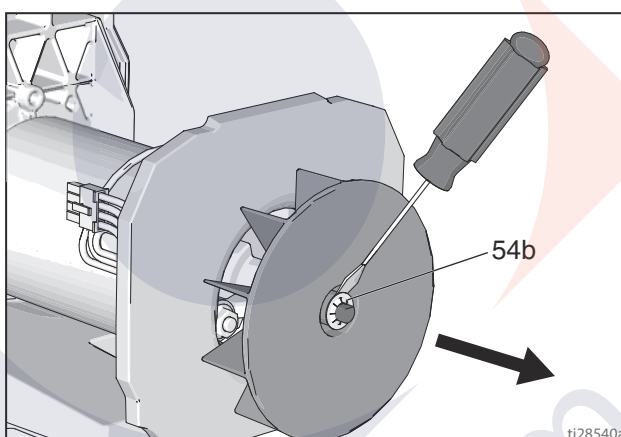

- b. Remove fan from motor shaft.
- c. Install new fan on the motor shaft with the fins facing the motor.
- d. Place a new push nut (54b) on a 3/8" or 10mm socket.

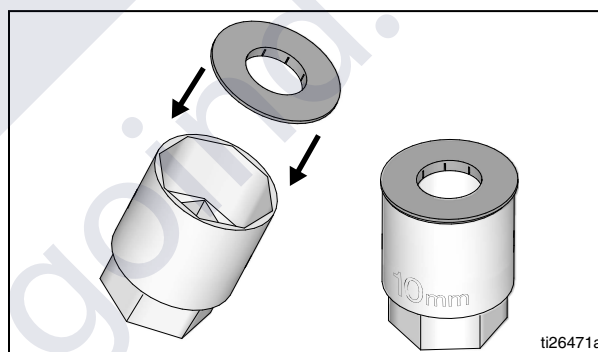

- e. Position the push nut and socket at the end of the motor shaft. Use a small or light (8 oz./225g) hammer to drive the push nut (54b) onto the shaft.

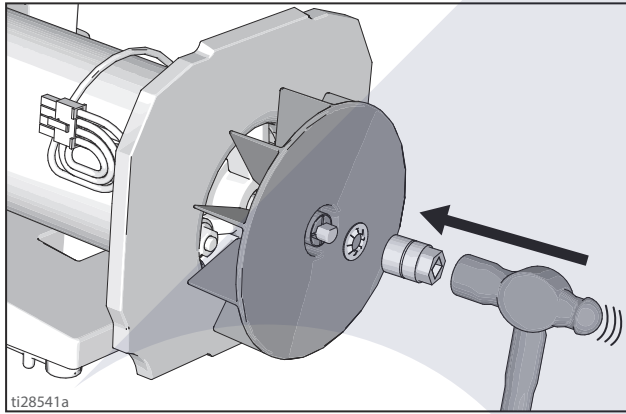

5. Clutch Fan Replacement

- a. Pry push nut (54b) off the motor shaft with a small screwdriver.
- b. Remove and discard old push nut (54b), washer (54c), fan, and shaft adapter (54d). If present, the shaft adapter requires a 5/64" hex key to loosen the setscrew. The application of heat is required to loosen the setscrew.

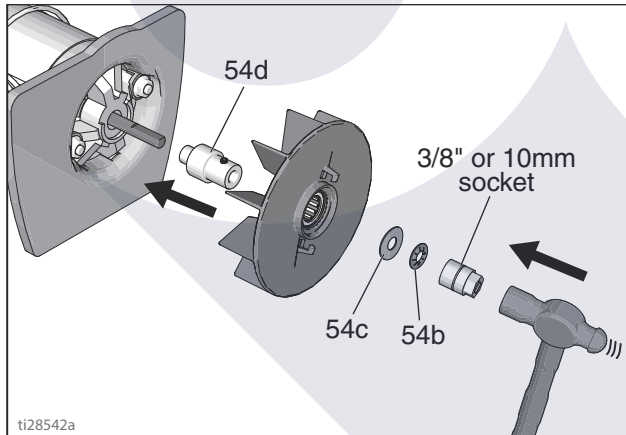

- c. Slide the new shaft adapter (54d) on to the motor shaft. If using the adapter with setscrew, apply thread locker (supplied in kit) to setscrew. Thread setscrew into shaft adapter (54d) and torque to 20-25 in-lb (2.3 - 2.8 N•m).
- d. Rotate fan clockwise while sliding fan onto shaft adapter (54d) with the fins facing the motor. Slide wave washer (54c) onto motor shaft.

- e. Place a push nut (54b) on a 3/8" or 10mm socket.
- f. Position the push nut and socket at the end of the motor shaft. Use a small or light (8 oz./225g) hammer to drive the push nut onto the shaft compressing the wave washer.

- 6. Slide motor shield (8) over the motor.
- 7. Secure the motor shield (8) using the two machine screws (12) removed earlier.

Gear & Yoke Replacement

Disassembly

- 1. Perform **Pressure Relief Procedure**, on page 1.
- 2. Unplug sprayer.
- 3. If necessary remove paint shield (14). Paint shield is not included on all models.
- 4. Position sprayer so front cover (10) is pointing up.
- 5. **Open Easy Access Door** page 9.
- 6. Remove four front cover (10) screws (12) using a T-30 Torx. Move front cover (10) to the side, support cover so that it is not hanging by the cable.
- 7. Remove pump assembly (7) by sliding it off the mounting pins. Set the pump assembly to the side.

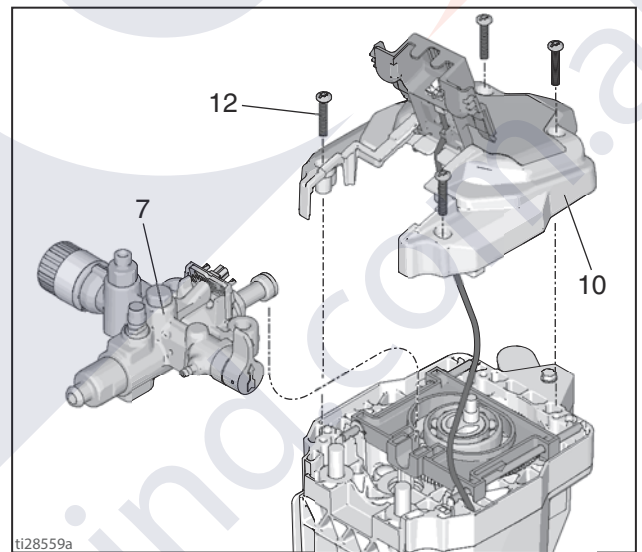

8. Remove yoke (D) with the two yoke guide rods (C) from the drive housing.
9. Remove gear (A) from drive housing.

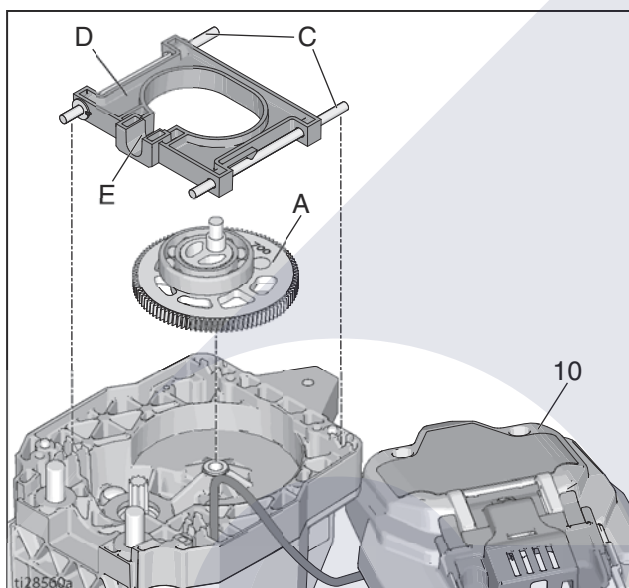

Assembly

1. Use applicator brush to spread entire contents of grease tube (included in kit) into gear teeth. Grease must be worked into roots of gear teeth to ensure long life.
2. Carefully position new gear (A) in drive housing. Make certain motor drive gear meshes with new gear (A).
3. Install yoke (D) with slot (E) facing out for pump piston as shown.
4. Apply grease to yoke guide rods (C).
5. Install front cover (10) and cover screws (12).

NOTICE

If yoke guide rods (C) drop out of position during assembly, damage to cover will occur when cover is tightened. Always check position of guide rods before tightening cover.

Take care to not pinch wiring harness (10c) between pump drive housing and between front cover (10). To prevent wiring harness damage, use a needle-nose pliers to move harness.

6. Install pump assembly and close easy access door. See **Pressure Control Replacement** page 9 Assembly for details.

Control

Control Board Replacement

Refer to your Owners/Operation manual for wiring diagrams.

Note color and location of all wires connected to the control board before you start the control board replacement.

Removal

1. Perform **Pressure Relief Procedure**, on page 1.
2. Unplug sprayer.
3. **Remove Motor Shield** page 3.
4. Disconnect pressure switch (10c) and motor connector from control board (15).
5. Disconnect ON/OFF switch (17) leads and power cord (3) from control board (15).
6. Remove screw (16) securing control board to drive housing.

Installation

1. Carefully slide new control board (15) into place on the side of the drive housing. Secure with screw (16) and torque. See **Drive Assembly Drawing** page 2 for torque.

2. Reconnect the power cord connector(s) to the correct leads on the control board (15).
3. Connect appropriate control board (15) lead(s) to the ON/OFF switch (17).
4. Reattach pressure switch (10c) and motor connector to control board (15).
5. **Install Motor Shield** page 3.

Fuse Replacement

If fuse is blown, check for:

- Pinched or shorted wires
- A defective motor
- A locked or frozen pump

1. Perform **Pressure Relief Procedure**, on page 1.
2. Unplug sprayer.
3. **Remove Motor Shield** page 3.
4. Remove fuse (15a) from control board (15).
5. Install new fuse (15a) on control board (15).
6. **Install Motor Shield** page 3.

Pump

Pump Assembly Drawing

Ref.	Torque	Ref.	Torque	Ref.	Torque
	140-160 in-lb (16 - 18 N•m)		30-35 in-lb (3.4 - 4.0 N•m)		320-380 in-lb (36 - 43 N•m)
	270-330 in-lb (30 - 37 N•m)		220-250 in-lb (25 - 28 N•m)		

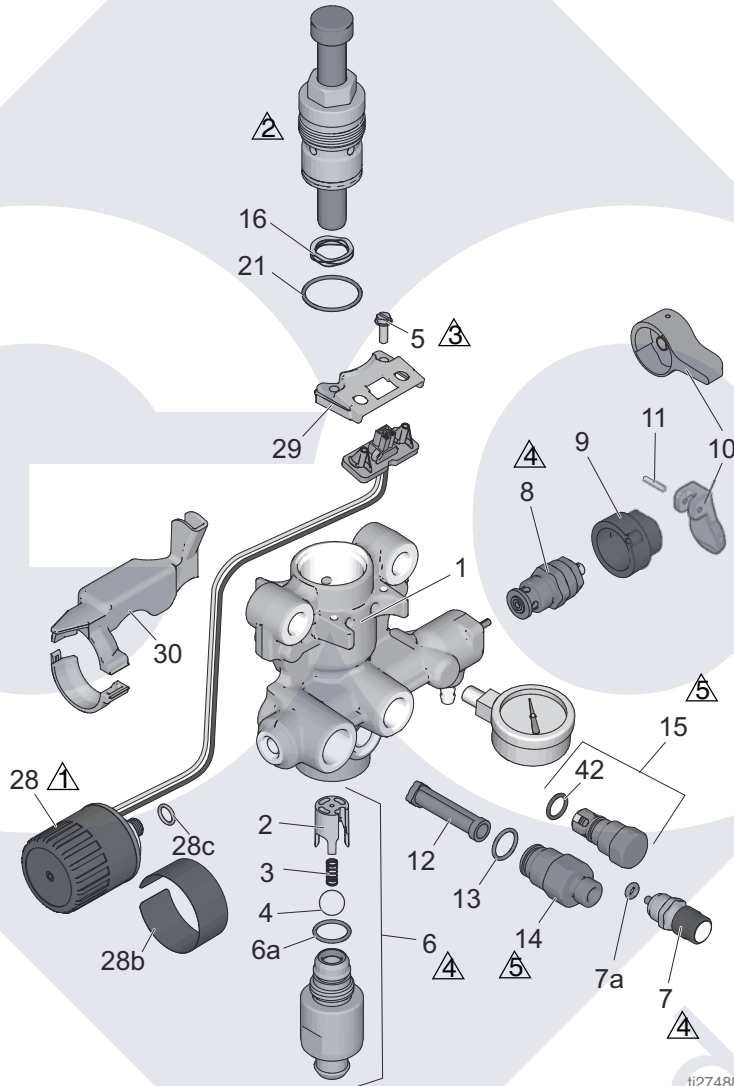

ti27488a1

Ref.	Description
1	Pump housing
2	Ball guide
3	Compression spring
4	Ball 0.5 inch
5	Screw
6	Pump inlet valve kit
6a	O-ring
7	PushPump button kit
7a	O-ring
8	Prime/Spray (Drain) Valve
9	Valve base (Not used on all models.)
10	Prime/Spray Valve handle

Ref.	Description
11	Grooved pin
12	Filter (Not installed on all models.)
13	O-ring
14	Pump filter housing kit
15	Pump outlet valve kit
16	Packing spring
21	O-ring
28	Pressure control
28b	Control label
28c	O-ring
29	Electrical connector bracket
30	Wire shield
42	O-ring

Pressure Control Replacement

Disassembly

1. Perform **Pressure Relief Procedure**, on page 1.
2. Unplug sprayer.

Open Easy Access Door

3. Pull tabs on sides of the easy access door pump towards you while pushing the entire door away from the inlet end of the pump.
4. Now lift the door so that it swivels out of the way.

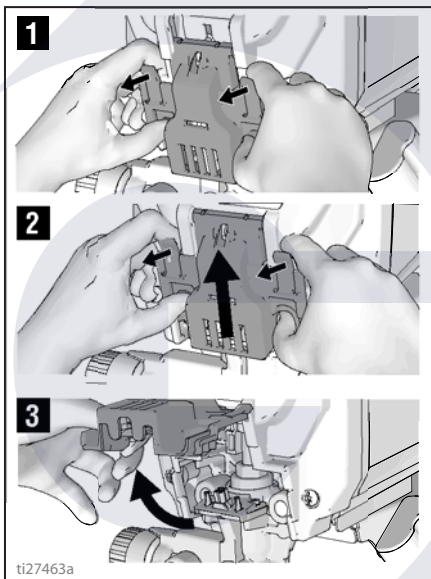

5. Remove pump by sliding it off the mounting pins.
6. Remove wire shield (30).
 - Unsnap the wire shield. On some models a retaining screw must be removed from the pump housing (1).
 - Save wire shield (30).
 - Note wire routing, wires on new pressure control will be routed the same way.
7. Remove the two screws (5) from electrical connector bracket (29). Save the screws.
8. Turn pressure control knob fully counterclockwise to expose the wrench flats. Remove pressure control (28) with wire and electrical connector bracket (29). Verify the O-ring (28c) has been removed from the pump housing (1).

Assembly

1. Examine pressure control (28) to verify that O-ring (28c) is on the pressure control (28). If O-ring is not installed on pressure control, install O-ring.
2. Apply one or two drops of thread locking adhesive (included in kit) to threads of pressure control (28). Assemble pressure control (28) into pump housing (1) and torque. See **Pump Assembly Drawing** page 8 for torque.
3. Route wire from pressure control (28) with electrical connector bracket (29) along pump housing (1) to mounting location.
4. Secure electrical connector bracket (29) to pump housing (1) with screws (5) removed earlier and torque. See **Pump Assembly Drawing** page 8 for torque.
5. Install wire shield (30).
 - Make certain wire is under wire shield (30).
 - Snap the wire shield around the pump housing (1). On some models, install retaining screw (5) into pump housing (1) and torque. See **Pump Assembly Drawing** page 8 for torque.
6. Turn pressure control knob clockwise as far as it will go. Apply pressure control label (cl) to knob. To position label correctly, see note below:

NOTE: When properly positioned, the function indicator (fi) and hi-spray position symbol on pressure control label (cl) are aligned.

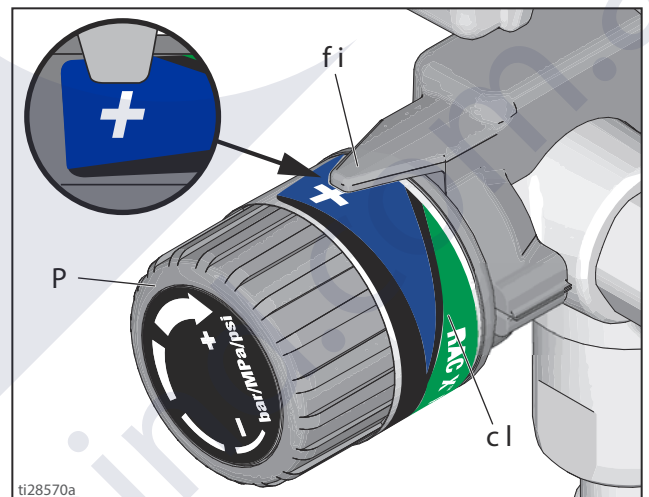

- Slide pump assembly onto the mounting pins.

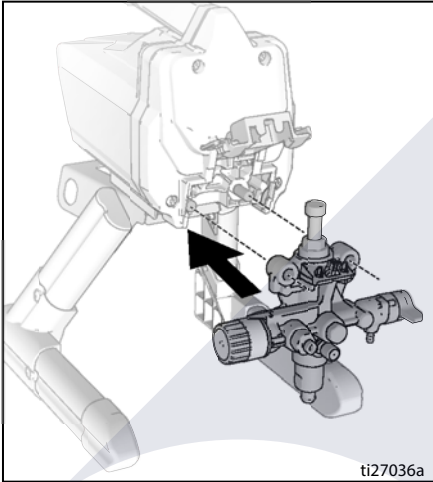

- Move pump displacement rod up or down until cap is level with the opening in the yoke.

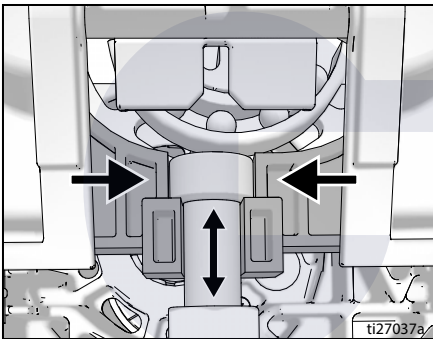

Close Easy Access Door

- Swing easy access door pump door closed while pushing the entire door towards the inlet end of the pump.

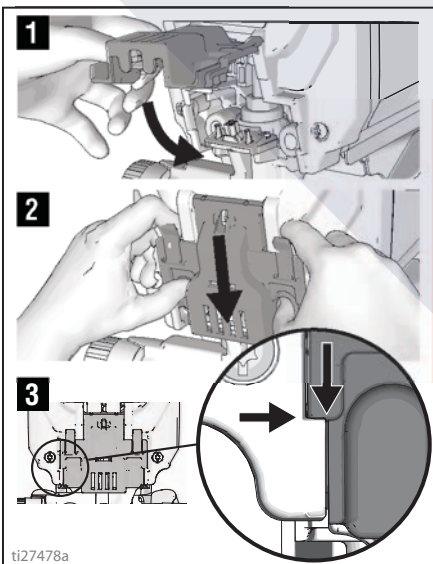

NOTE: Door must be fully closed and latched before sprayer will operate.

Prime/Spray Valve and Knob Replacement

Disassembly

- Perform **Pressure Relief Procedure**, on page 1.
- Unplug sprayer.
- Turn knob (A) up to **SPRAY** position.
- Remove pin (B) with pin punch and hammer.

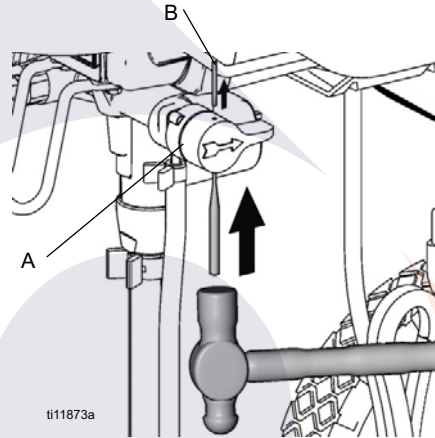

- Remove knob (A) and base (C).

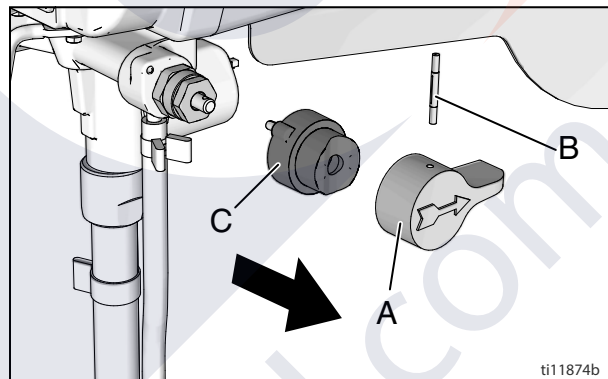

- Remove valve stem assembly (D) from pump housing (1). Make certain gasket (X) and seat (Z) do not stay in pump housing (1).

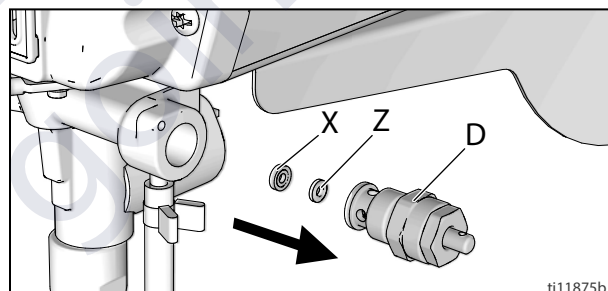

Assembly

- Apply sealant (provided in kit) to valve threads. Install valve stem assembly in pump manifold and torque. See **Pump Assembly Drawing** page 8 for torque.
- Install base (C) on valve, aligning pin (E) on base (C) with hole (F) on pump housing (1).

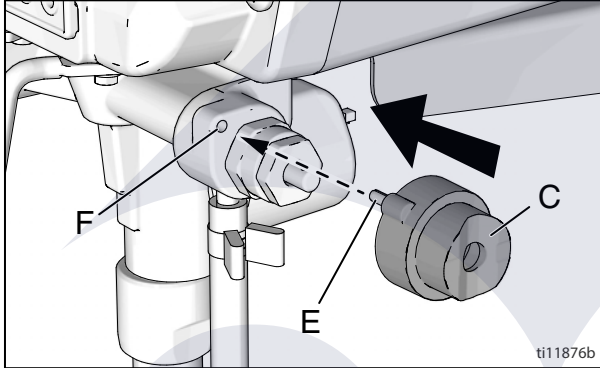

- Rotate valve stem with a pin punch until hole is perpendicular.

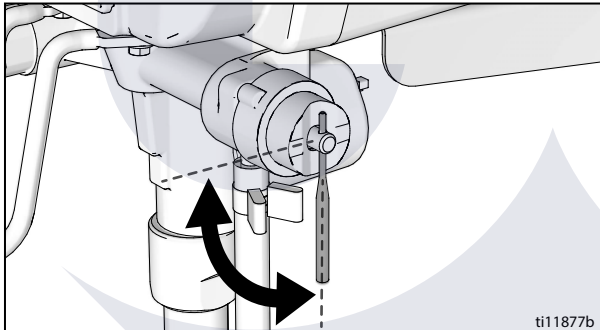

- Install knob (A) over base (C).
- Place knob in SPRAY position.
- Insert end of pin punch through hole in knob (A), to make sure knob and valve stem are aligned.

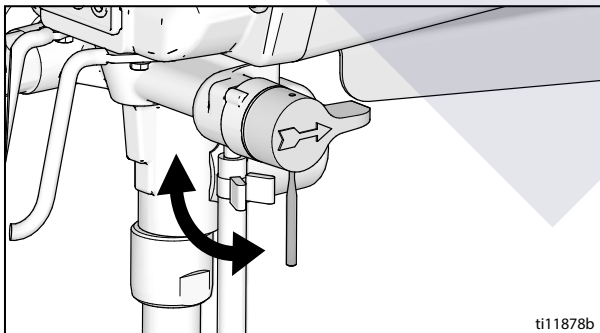

- Install pin (B) through hole in knob (A). Tap pin through knob with hammer. End of pin will be flush with top of hole in knob when correctly installed.

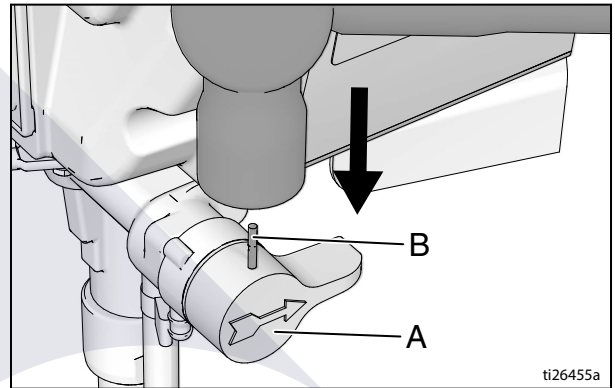

GX Models Only

- Remove valve stem assembly (D) from pump housing (1). Make certain gasket (H) and seat (G) do not stay in pump housing (1).

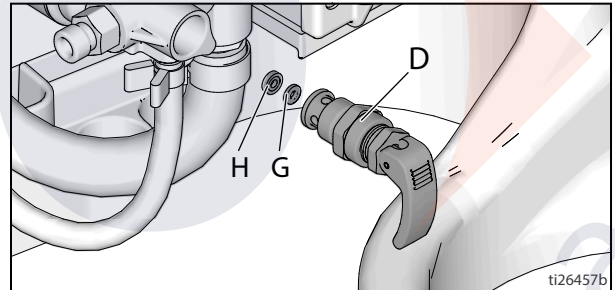

- Apply sealant (provided in kit) to valve threads. Install valve stem assembly in pump housing (1) and torque. See **Pump Assembly Drawing** for torque.

Pump Outlet Valve Replacement

Disassembly

- Perform **Pressure Relief Procedure**, on page 1.
- Unplug sprayer.
- Remove outlet valve (15) from pump housing (1).
- Clean all dried residue from around pump outlet seat area in pump housing (1).

Assembly

- Verify that O-rings are installed.
- Thread new pump outlet valve (15) into pump housing (1). Torque, see **Pump Assembly Drawing** page 8 for torque.

Pump Inlet Valve Replacement

Disassembly

1. Perform **Pressure Relief Procedure**, on page 1.
2. Unplug sprayer.
3. Remove suction tube. Hopper may need to be removed on models with a hopper.
4. Remove inlet valve fitting (6) from pump housing (1) and discard. Make certain inlet ball (4), spring (3), and ball guide (2) are removed from pump housing (1).
5. Clean all dried residue from around pump inlet sealing area in pump housing (1).

Assembly

1. Assemble ball guide (2), spring (3), and ball (4) into pump housing (1).
 - a. The ball guide (2) is keyed for proper alignment.
 - b. Make certain the bump on the ball guide (2) is aligned with the slot in the pump housing (1). Slide ball guide (2) into pump housing(1).
 - c. Install spring (3) over ball stop pin in the ball guide (2).

- d. Install ball (4) into ball guide (2).
2. Make certain O-ring (6a) is installed on inlet valve housing (6).
3. Thread new inlet valve housing into pump housing (1) and torque. See **Pump Assembly Drawing** page 8 for torque.
4. Use a pencil or similar object to push on the ball (4) through the inlet valve intake to make sure the ball moves free.

PushPrime Button Replacement

1. Perform **Pressure Relief Procedure**, on page 1.
2. Unplug sprayer.
3. Remove PushPrime button (7) from pump housing (1) and discard.
4. Clean all dried residue from around PushPrime button sealing area in pump housing (1).
5. Verify that O-ring (7a) is installed on the PushPrime button (7).
6. Thread new PushPrime button (7) into pump housing (1) and torque. See **Pump Assembly Drawing** page 8 for torque.

goind.com.au

Pump Packing O-ring Replacement

Remove pump packing assembly (25) and replace O-ring (21) with new one.

1. Remove pump housing (1) from sprayer. See **Pressure Control Replacement**, on page 9 for pump removal.
2. Insert hex end of pump into hex tool in the sprayer frame and turn counter-clockwise to loosen assembly. Location of the hex varies depending on the sprayer.

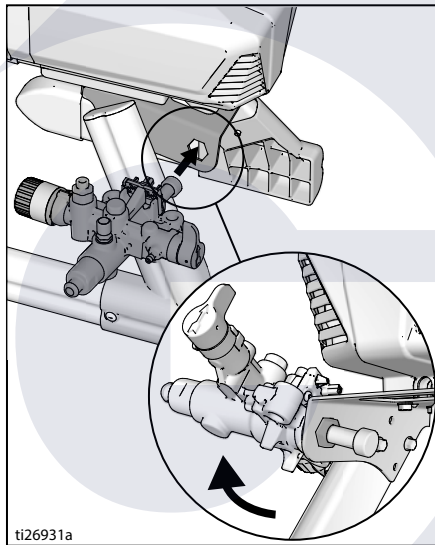

3. Remove entire packing assembly (25) from pump housing (21) including the packing spring (16).
4. Remove and replace O-ring (21).

NOTICE

Be careful not to lose the packing spring that is installed on the pump rod. Operation without the packing spring will cause early pump failure.

5. While holding the pump body upside down start threading the new packing assembly in by hand.

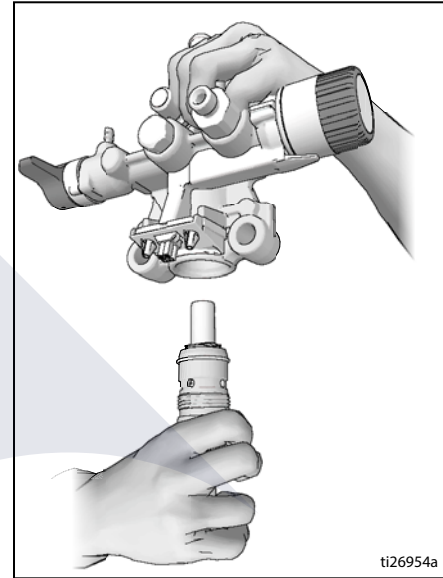

6. Insert hex end of pump into hex tool in the sprayer frame and torque. See **Pump Assembly Drawing** page 8 for torque.
7. Install pump housing (1) into sprayer. See **Pressure Control Replacement**, on page 9 for pump installation.

Suction Tube Replacement

1. Remove suction tube (26 or 37) from pump inlet.
2. Remove clamp and strainer from suction tube.
3. Locate new suction tube (26 or 37).
4. Install strainer.
5. Slide clamp over the other end of the suction tube.
6. Install suction tube onto pump inlet and secure with clamp.

Assembly Verification

After assembly is complete, follow the Setup and Start Up instructions in your Owners/Operation manual to verify proper sprayer operation.

Graco Information

For the latest information about Graco products, visit www.graco.com

TO PLACE AN ORDER, contact your Graco distributor or call 1-800-690-2894 to identify the nearest distributor.

*All written and visual data contained in this document reflects the latest product information available at the time of publication.
Graco reserves the right to make changes at any time without notice.*

For patent information, see www.graco.com/patents. Original instructions. This manual contains English. MM 3A3951

Graco Headquarters: Minneapolis/**International Offices:** Belgium, China, Japan, Korea

GRACO INC. AND SUBSIDIARIES • P.O. BOX 1441 • MINNEAPOLIS MN 55440-1441 • USA

Copyright 2016, Graco Inc. All Graco manufacturing locations are registered to ISO 9001.

www.graco.com

Revision D, June 2020