

TapeLazer™ HP Automatic

3A8108B

EN

*For application of traffic tape on roads and pavement. For professional use only.
For outdoor use only.
Not approved for use in explosive atmosphere or hazardous (classified) locations.*

145 psi (1.0 MPa, 10.0 bar) Maximum Working Pressure

Models: 20A024, 20A140



Important Safety Instructions



Read all warnings and instructions in this manual and related manuals before using the equipment. Save these instructions.



Contents

Models	3
Warnings	4
Component Identification	6
Setup/Startup	7
Pressure Relief Procedure	7
Initial Setup	8
Connecting a LineDriver	8
Tape and Roller Setup	10
Loading Tape	10
Roller Adjustment	11
Blade Guard Removal and Installation	14
Carriage Adjustment	16
Caster Wheel Adjustments	17
Handlebar Adjustment	18
Engine Start	19
Initial Taping Setup	20
Language	20
Time and Date, and Distance Units	20
Calibration	21
Operation	23
Modes of Operation	23
Tape Application Assembly Positions	24
TapeLazer LiveLook Display	25
Applying Tape	26
System Delay	27
Operating System Delay	27
System Delay Example - Semi-Auto Mode/Skip Line	28
System Delay Example - Auto Mode/Skip Line	29
System Delay Example - Manual Mode/Skip Line	30
System Delay Example - Semi-Auto and Auto Mode/Solid Line	31
System Delay Example - Manual Mode/Solid Line	32
Cut Delay	33
Measure Mode	34
Splicing Tape	35
Setup/Information	36
Settings	37
Information	38
Data Logging	39
Maintenance	40
Blade Replacement	41
Brake Removal and Replacement	42
Troubleshooting	43
Parts	52
Air Line Schematic	62
Air Line Connection Sequence	63
Wiring Diagram	64
Universal Symbols Key	65
Technical Specifications	66
Graco Standard Warranty	67

Models

Part	Description	Maximum Working Pressure psi (MPa, bar)	Approvals
20A024	TapeLazer HP Automatic	145 psi (1 MPa, 10.0 bar)	  
20A140	TapeLazer HP Automatic with LazerGuide 3000*		

* Refer to LazerGuide instruction manual 3A5294 (included with unit) for reference on how to operate the LazerGuide system.











Related Manuals

Manual in English	Description
312540	LineDriver® Operations, Parts, and Repair Manual
3A6623	LineDriver™ ES Operations, Parts, and Repair Manual
3A5294	LazerGuide™ Instructions
37Z4V611	Honda Engine Manual







Warnings

Warnings

The following warnings are for the setup, use, maintenance, and repair of this equipment. The exclamation point symbol alerts you to a general warning and the hazard symbols refer to procedure-specific risks. When these symbols appear in the body of this manual or on warning labels, refer back to these Warnings. Product-specific hazard symbols and warnings not covered in this section may appear throughout the body of this manual where applicable.

 WARNING	
 	<p>MOVING PARTS HAZARD Moving parts can pinch, cut or amputate fingers and other body parts.</p> <ul style="list-style-type: none">• Keep clear of moving parts.• Do not operate equipment with protective guards or covers removed.• Before cleaning, checking, or servicing equipment, follow the Pressure Relief Procedure and disconnect all power sources.
	<p>BURN HAZARD Equipment surfaces and compressed air components can become very hot during operation. To avoid severe burns:</p> <ul style="list-style-type: none">• Do not touch compressed air components or equipment.
 	<p>TRAFFIC HAZARD Vehicle strikes may result in serious injury or death.</p> <ul style="list-style-type: none">• Do not operate in traffic.• Use traffic control.• Follow local highway and transportation regulations for traffic control. Refer to Manual on Uniform Traffic Control Devices (MUTCD), U.S. Department of Transportation, Federal Highway Administration, or local regulations.
	<p>FIRE AND EXPLOSION HAZARD Flammable fumes in work area can ignite or explode. To help prevent fire and explosion:</p> <ul style="list-style-type: none">• Use equipment only in well-ventilated area.• Do not fill fuel tank while engine is running or hot; shut off engine and let it cool. Fuel is flammable and can ignite or explode if spilled on hot surface.• Keep work area free of debris, including solvent, rags and gasoline.• Keep a working fire extinguisher in the work area.
 	<p>BATTERY HAZARD Lead-acid batteries produce explosive gases and contain sulfuric acid that can cause severe burns. To avoid sparks and injury when handling or working with a lead-acid battery:</p> <ul style="list-style-type: none">• Read and follow the battery manufacturer's warnings.• Exercise caution when working with metallic tools or conductors to prevent short circuits and sparks.• Keep all sparks, flames, and cigarettes away from batteries.• Always wear protective eyewear and protective equipment for face, hands, and body.• If you have direct contact with battery fluid, flush with water and consult a physician immediately.• Installation and maintenance must be performed by knowledgeable personnel only.
	<p>CARBON MONOXIDE HAZARD Exhaust contains poisonous carbon monoxide, which is colorless and odorless. Breathing carbon monoxide can cause death.</p> <ul style="list-style-type: none">• Do not operate internal combustion engine in an enclosed area.

WARNING

 	<p>EQUIPMENT MISUSE HAZARD Misuse can cause death or serious injury.</p> <ul style="list-style-type: none"> • Do not operate the unit when fatigued or under the influence of drugs or alcohol. • Do not exceed the maximum working pressure rating of the lowest rated system component. See Technical Specifications in all equipment manuals. • Do not leave the work area while equipment is energized or under pressure. • Turn off all equipment and follow the Pressure Relief Procedure when equipment is not in use. • Check equipment daily. Repair or replace worn or damaged parts immediately with genuine manufacturer's replacement parts only. • Do not alter or modify equipment. Alterations or modifications may void agency approvals and create safety hazards. • Make sure all equipment is rated and approved for the environment in which you are using it. • Use equipment only for its intended purpose. Call your distributor for information. • Keep children and animals away from work area. • Comply with all applicable safety regulations.
	<p>ELECTRIC SHOCK HAZARD Hazardous voltage is present in control box while engine is running.</p> <ul style="list-style-type: none"> • Turn off engine before servicing equipment.
	<p>LASER LIGHT HAZARD: AVOID DIRECT EYE CONTACT Eye exposure to Class IIIa3/3R levels of laser light can potentially present an eye (retinal) injury hazard, including spot blindness or other retinal injury. To avoid direct eye exposure:</p> <ul style="list-style-type: none"> • Never look directly in to a laser beam or point the beam into the eyes of others, even at long distances. • Never shine the laser at mirror like surfaces which can cause specular reflections of the beam. • Always set the laser at a height and angle that prevents the beam from shining into people's eyes. • Immediately terminate laser emissions if personnel, animals or reflective objects approach the beam. • Always turn off laser when unattended. • Do not remove any warning labels from the laser. • Only properly trained laser operators are to use this product. • Never allow beams to be aimed toward traffic, vehicles, or heavy equipment. Even when not damaging at long distances, the high brightness of lasers can distract or disrupt vehicle operations. • Never point a laser at an aircraft or law enforcement personnel. This is considered a felony in most locations, with the possibility of jail time, heavy fines or both. • Do not disassemble laser product. Return to factory for all service procedures. • Laser must be turned OFF when cleaning the lens, so as not to create unwanted laser refraction.
	<p>LASER RADIATION HAZARD Use of controls or adjustments or performance of procedures other than those specified herein may result in hazardous radiation exposure.</p> <ul style="list-style-type: none"> • Do not attempt to open or disassemble the laser housing under any circumstances. Doing so may cause exposure to potentially hazardous levels of laser radiation. • No serviceable parts within. Unit is factory sealed.
	<p>PERSONAL PROTECTIVE EQUIPMENT Use appropriate protective equipment when in the work area to help prevent serious injury, including eye injury, hearing loss, inhalation of toxic fumes, and burns. Protective equipment includes but is not limited to:</p> <ul style="list-style-type: none"> • Protective eyewear, protective clothing and gloves, and hearing protection.

Component Identification

Component Identification



ti39203a

1	LiveLook™ display
2	Carriage raise/lower and engine stop
3	USB charger/job logging download
4	Engine throttle
5	Carriage locking pin
6	Tape roll support spindle
7	Air drain valve
8	Cutting blade
9	Tape brake roller
10	12 volt battery

11	Handlebar
12	Front wheel release lever
13	Identification label
14	Tape application button
15	Carriage
16	LineDriver hitch
17	Parking brake
18	Tape brake
19	Tape application assembly
20	Solenoid manifold

Setup/Startup

Pressure Relief Procedure



This equipment stays pressurized until pressure is manually relieved. To help prevent serious injury from moving parts, follow the pressure relief procedure before cleaning, checking, or servicing the equipment.

1. Turn engine off by pressing and holding the Engine Stop. The carriage will automatically raise when the engine is turned off.

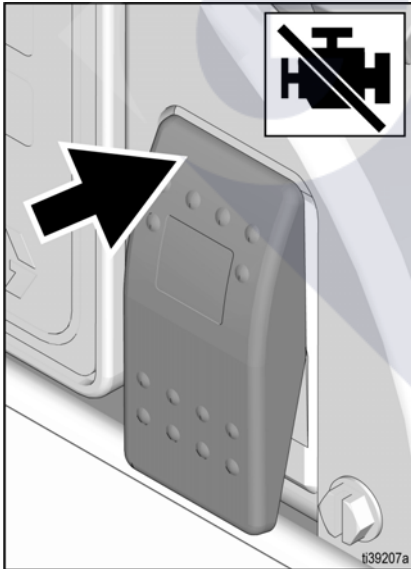

2. Lock carriage in the up position by turning and pushing locking pins in on both sides of the carriage.

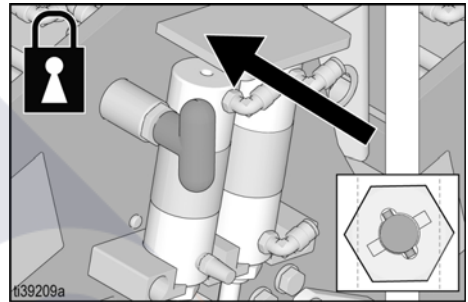

3. Open air drain valve, as shown, to relieve air pressure.

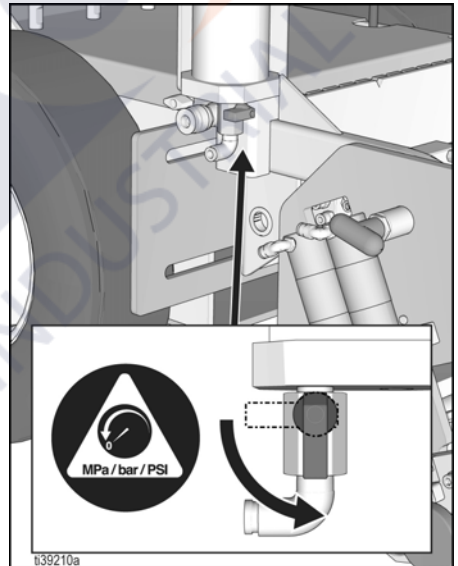

Initial Setup



To help prevent serious injury from pinching or cutting, keep clear of the cutting blade and moving carriage parts.

1. Turn engine off and perform **Pressure Relief Procedure**, page 7.
2. Check engine and air compressor oil levels.

NOTE: Use ONLY SAE 10W-30 (summer) or 5W-30 (winter) engine oil. Use ONLY synthetic air compressor oil for the compressor.

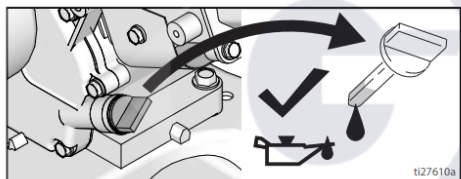

3. Fill fuel tank.
4. Remove blade guard. See, **Blade Guard Removal and Installation**, page 14

Connecting a LineDriver

It is recommended to use a LineDriver in conjunction with the TapeLazer. To connect the TapeLazer to a LineDriver, follow the steps below.

1. Install LineDriver coupler to TapeLazer hitch ball.

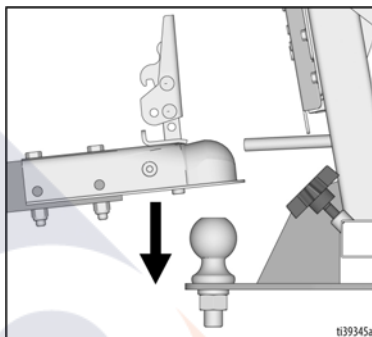

2. Latch coupler to locked position.

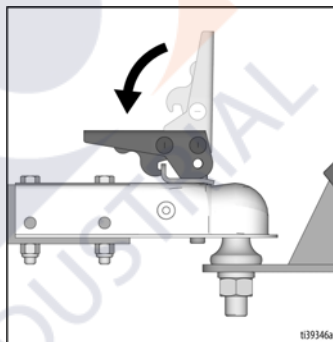

3. Insert safety pin into latch.

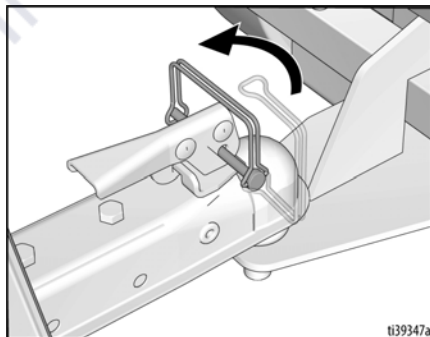

- Adjust LineDriver seat forward/backward with lever below seat.

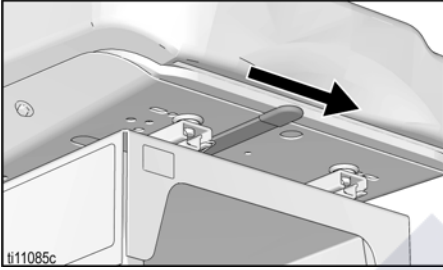

NOTE: To help reduce fatigue, adjust one pedal for a full motion forward and one for full motion in reverse.

- Loosen two bolts on topside of pedals on LineDriver.

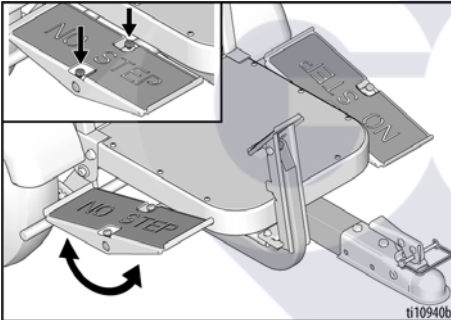

- Rotate pedal on LineDriver to desired position. Tighten bolts.
- See LineDriver manual for instructions on starting and operating LineDriver.

Tape and Roller Setup



Accurate tape and roller setup is essential to ensuring that the tape properly aligns into road inlay grooves and to ensure rollers remain free from adhesive primer. Failure to properly set the tape and rollers could make taping difficult.

Loading Tape

1. Perform pressure relief procedure, see **Pressure Relief Procedure**, page 7.
2. Remove end collar from tape support spindle.
3. Align inside collar in proper location along spindle, depending on the width of the tape, to position it correctly on the spindle.
4. Lock inside collar into position.

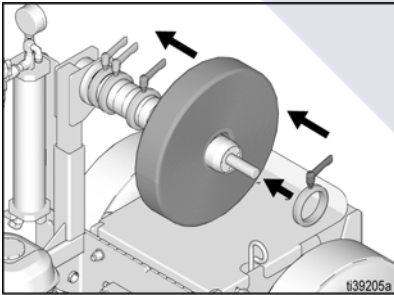

5. Load tape onto spindle so that the tape feeds from the bottom of the roll.

6. Re-install end collar.

NOTE: It is critical that the tape remain in tension during the application process. Prior to locking the end collar into place, press the collar into the tape roll so that the tape does not feed too fast during high speed applications.

7. Lock end collar into position.
8. Adjust the collars on the tape guide roller and the segments on the applicator and tamping rollers to match the position and width of the tape, see **Roller Adjustment**, page 11. Matching lines are provided on the rollers to allow for easy alignment of tape.

NOTE: Applicator and tamping rollers should be set up to match the width of the tape. If rollers are wider than the tape, the tape may not properly affix into road inlay grooves.

NOTE: It may be helpful to lift the brake (as shown below) before feeding tape, or if tape is difficult to pass through the rollers.

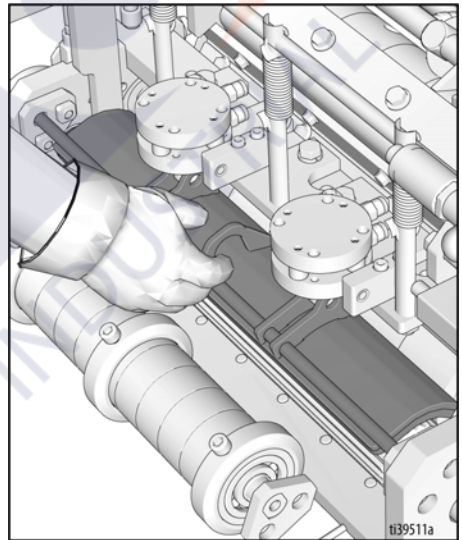

9. Feed tape through rollers as shown.

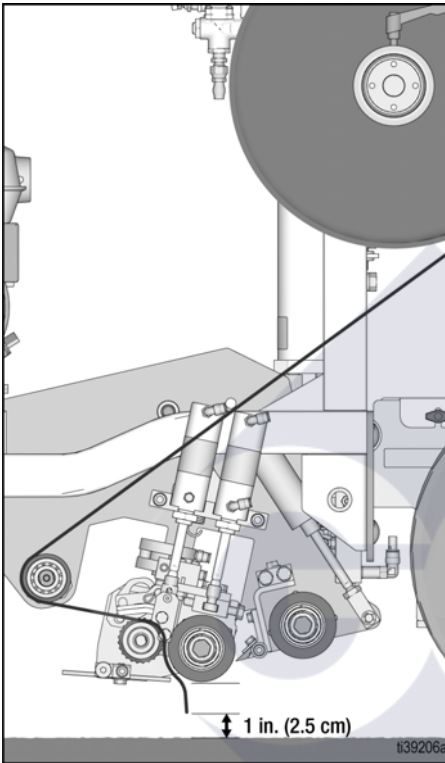

NOTE: When installing tape through the lower rollers, it is helpful to tamp the tape to the brake roller and feed it through by manually turning the roller (about half of a turn) until tape appears on the other side between the brake roller and applicator roller. Pull tape away from the brake roller and to within one inch of the ground.

Roller Adjustment

To help prevent injury from cutting, install the blade guard or remove blade prior to adjusting rollers.				

1. Perform pressure relief procedure, see **Pressure Relief Procedure**, page 7.
2. Using a 1/4 in. Allen wrench, adjust the tape collars on the guide roller to match the width and position of the tape.

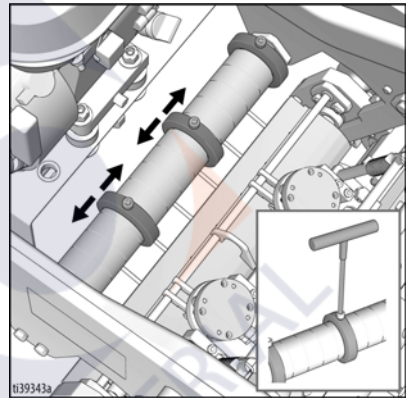

NOTE: It is recommended you either have the blade guard in place or remove the blade prior to removing the applicator roller. See **Blade Guard Removal and Installation**, page 14.

3. Remove front bolts on **both** sides of the carriage holding the pivot bar in place with a 1/4 in. Allen wrench.

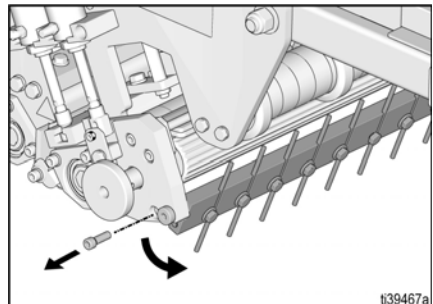

Setup/Startup

4. Rotate pivot bar away from applicator roller.
5. Using a 1/4 in. Allen wrench, remove the three bolts holding the end plate on the applicator roller.

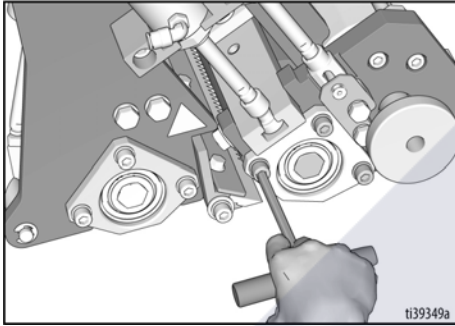

NOTE: It is only necessary to remove the end plate on one side of the carriage to remove the applicator roller.

6. Remove applicator roller and using a 1/4 in. Allen wrench remove the bolt on one end of the hex shaft. Loosen set screws in rollers to remove or adjust them to the necessary width and location to match the tape.

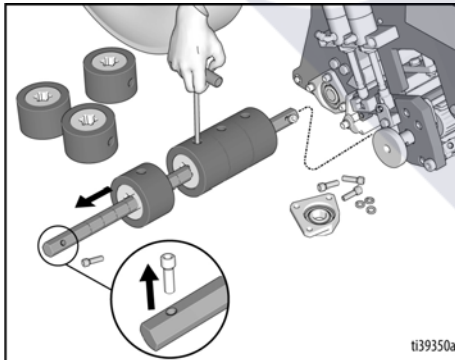

NOTE: Removed rollers can be stored on the vertical posts located in front of the handlebars.

7. Tighten set screws on roller segments once in place and re-install bolt on end of hex shaft.
8. Re-install applicator roller, plate and bolts. Tighten bolts with 1/4 in. Allen wrench.

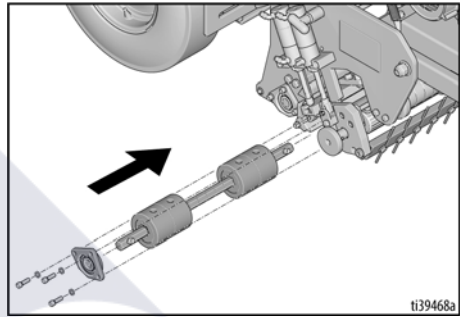

9. Rotate the pivot bar back into place and replace the bolts on both sides of the carriage.

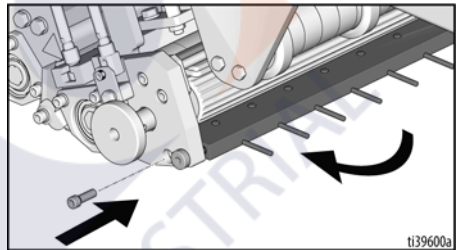

10. Using a 1/4 in. Allen wrench, remove the three bolts holding the end plate on the tamping roller.

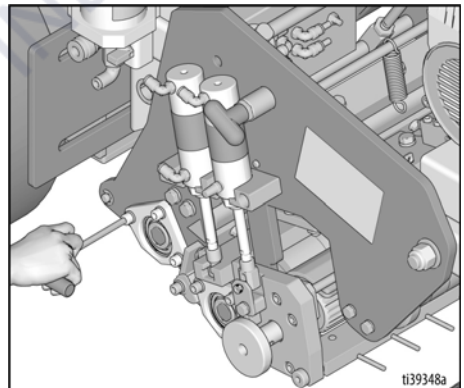

11. Remove tamping roller and using a 1/4 in. Allen wrench remove bolt on one end of the hex shaft. Loosen set screws in rollers to remove or adjust them to the necessary width and location to match the tape.

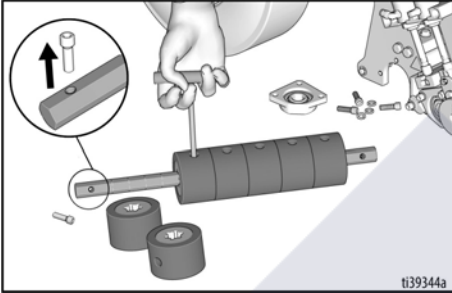

12. Tighten set screws on all roller segments once in place and re-install bolt on the end of hex shaft.
13. Re-install tamping roller, plate and bolts. Tighten bolts with 1/4 in. Allen wrench.

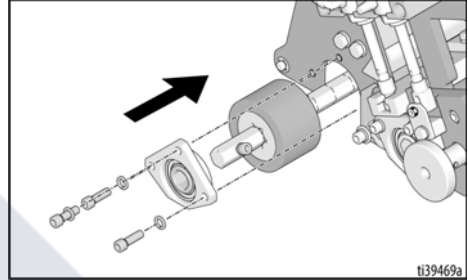

NOTE: Removed rollers can be stored on the vertical posts located in front of the handlebars.

Blade Guard Removal and Installation



To help prevent injury from cutting, install the blade guard or remove blade prior to adjusting rollers.

1. Perform pressure relief procedure, see **Pressure Relief Procedure**, page 7.
2. Using a 1/4 in. Allen wrench, loosen bolts holding blade guard in place on both sides of the unit.

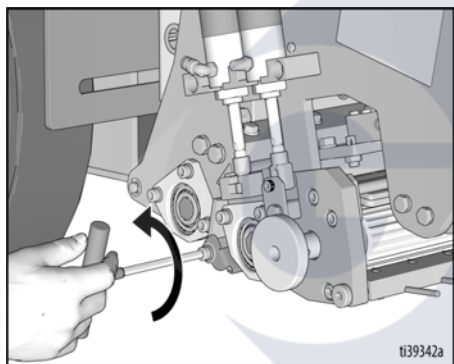

3. Remove blade guard.

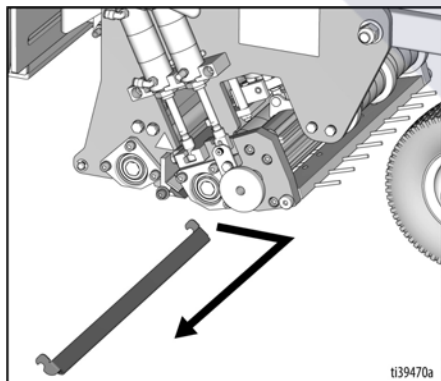

4. Tighten bolts.

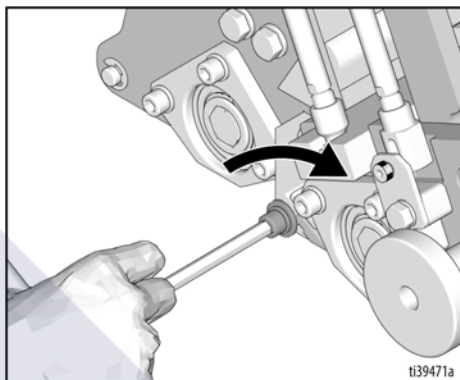

5. To re-install, use 1/4 in. Allen wrench to loosen bolts holding the blade in place.

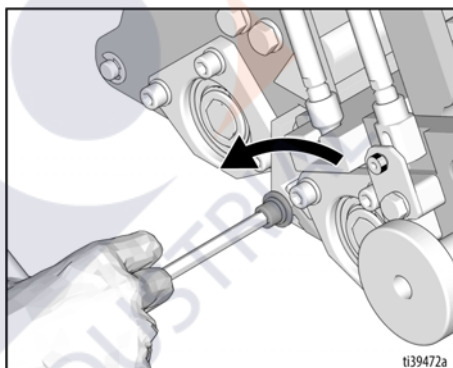

6. Carefully re-install blade guard.

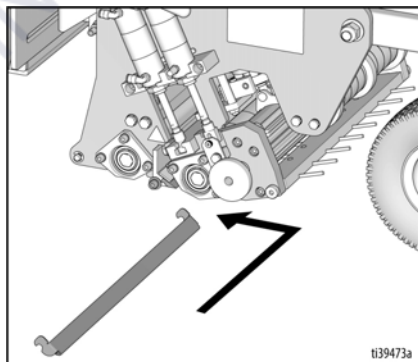

- Using a 1/4 in. Allen wrench, tighten bolts.

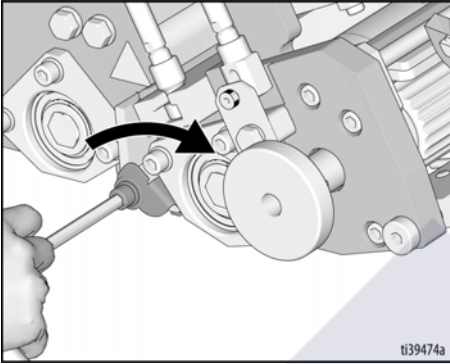

Carriage Adjustment



To help prevent serious injury from pinching or cutting, keep clear of the cutting blade and moving carriage parts.

Often it is desirable to adjust the carriage to an offset position to accommodate curbs or difficult areas along the road edge. To adjust the carriage into an offset position, follow the steps below:

1. Using a 3/4 in. wrench, loosen the four bolts connecting the carriage to the frame of the TapeLazer.

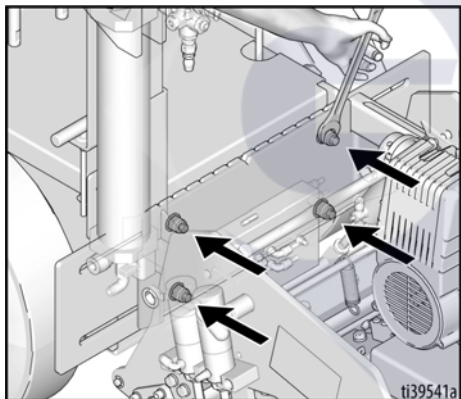

2. Slide carriage left or right to the desired location.

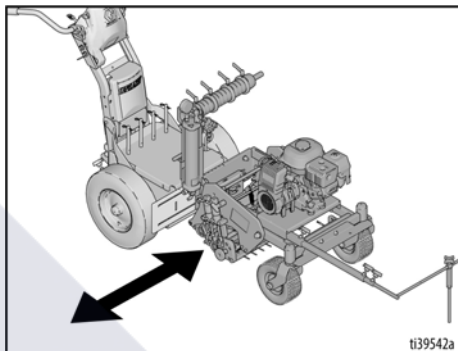

NOTE: Have a second person push down on the TapeLazer handlebars to relieve tension on the bolts while you slide the carriage right or left.

3. Notches are set in the carriage and frame at one inch intervals which match the lines on rollers to help with alignment. A larger center notch allows for easy reorientation to the center position.

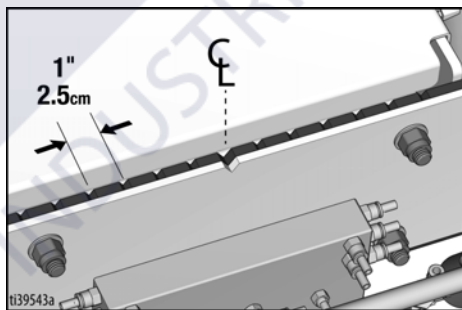

4. Tighten bolts.

Caster Wheel Adjustments

Two front wheels allow the operator to lay tape in straight lines. Over time, the unit may become misaligned and will need to be adjusted. One wheel is adjustable to assist with alignment. To properly align the front wheels, perform the following steps:

1. Loosen bolt on the front wheel bracket.

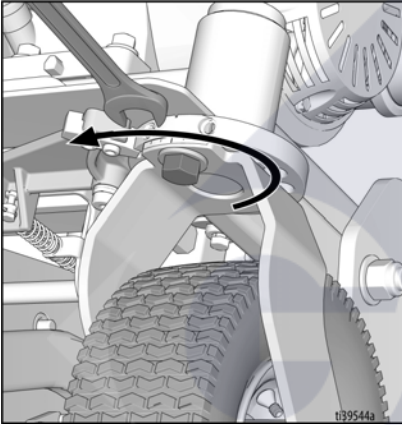

2. If taper arcs to the right, loosen left set screw and tighten right set screw for fine tune adjustment.

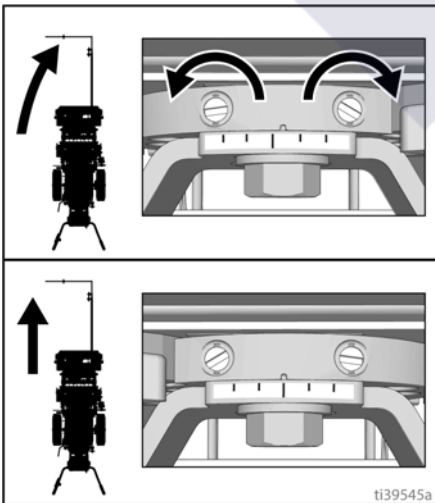

3. If taper arcs to the left, loosen right set screw and tighten left set screw.

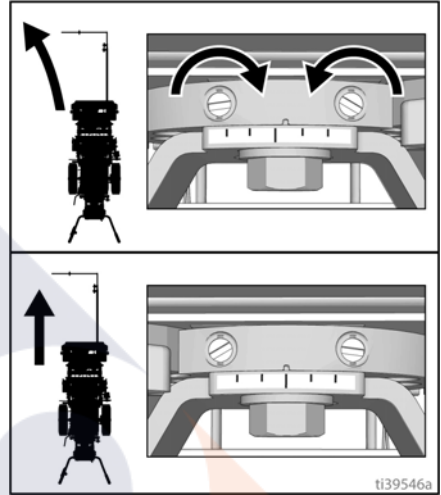

4. Roll the taper. Repeat steps 2 and 3 until taper rolls straight. Tighten bolt on wheel alignment plate to lock the new wheel setting.

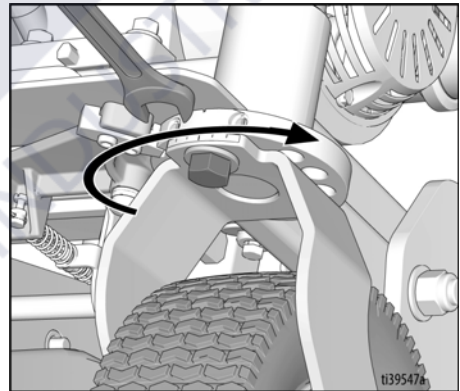

Handlebar Adjustment

The handlebar is adjustable, allowing users to customize the height and tilt for comfortable performance. To adjust handlebar, follow the steps below:

1. To adjust the tilt, use a 3/4 in. wrench to loosen the four bolts (two on each side) holding the handlebars to the display unit.

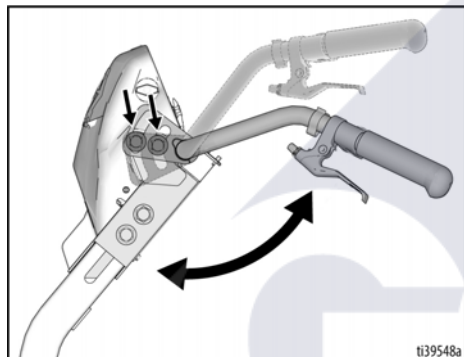

2. Tilt handlebars until they are in the desired location.
3. Re-tighten bolts.

1. To adjust the height of handlebars use a 3/4 in. wrench to loosen the four bolts (two on each side) holding the handlebars to the frame of the unit.

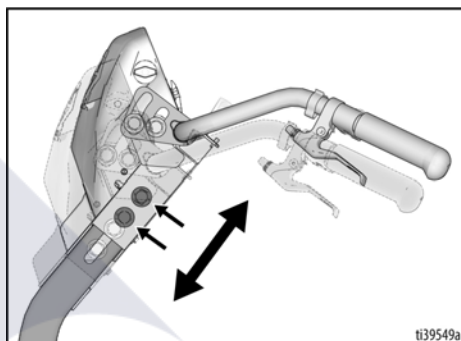

2. Slide handlebars and up or down to set the desired height.
3. Re-tighten bolts.

Engine Start

1. Perform **Pressure Relief Procedure**, page 7.
2. Move fuel valve to open.

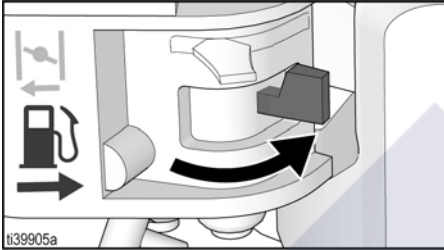

3. Move choke to closed.

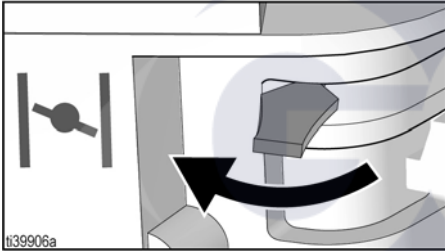

4. Set throttle to fast.

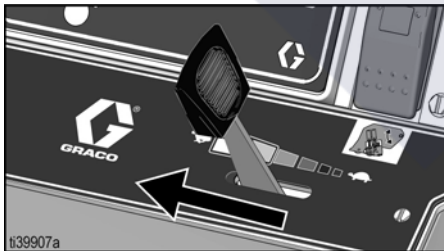

5. Set engine switch to on.

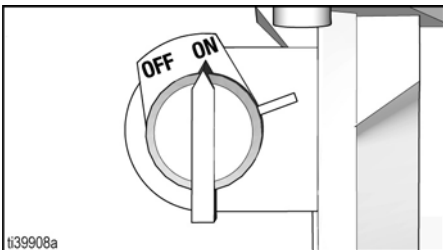

6. Pull starter cord.

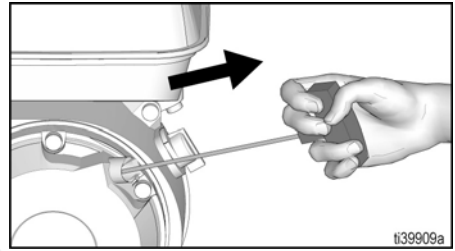

7. After engine starts, move choke to open.

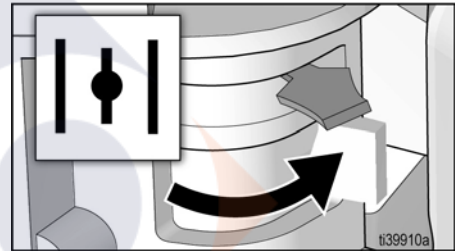

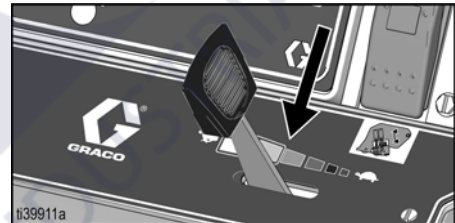

8. Set throttle to desired setting.



Initial Taping Setup

The initial setup prepares the taper for operation based on a number of user entered parameters. Language selections and the units of measure selections can be set before you start, or changed later.

Press   to cycle through the various menu options.

Language

From SETUP/INFO select appropriate language by pressing “D” until the language is outlined.

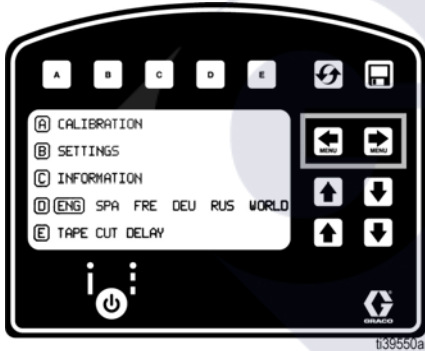

ENG = English
SPA = Spanish
FRE = French
DEU = German
RUS = Russian
WORLD = Symbols, see **Universal Symbols Key**, page 65.

NOTE: The default language can be changed at any time.

Time and Date, and Distance Units

Press SETTINGS “B” from the SETUP/INFO screen to access Time and Date, and Distance Units. Press “A” to adjust current date and time. Press “B” until the preferred distance measuring unit is outlined.

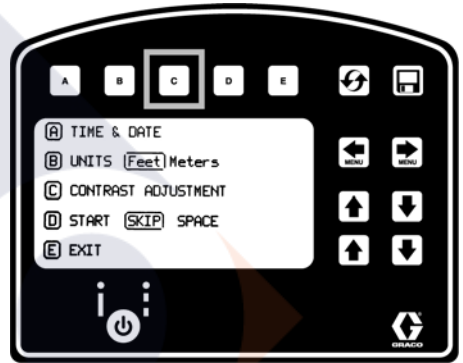

Calibration

1. Check rear tire pressure and fill to 55 +/- 5 psi (379 +/- 34 kpa), if necessary.
2. Extend steel tape to 25 ft (8 m) or longer.

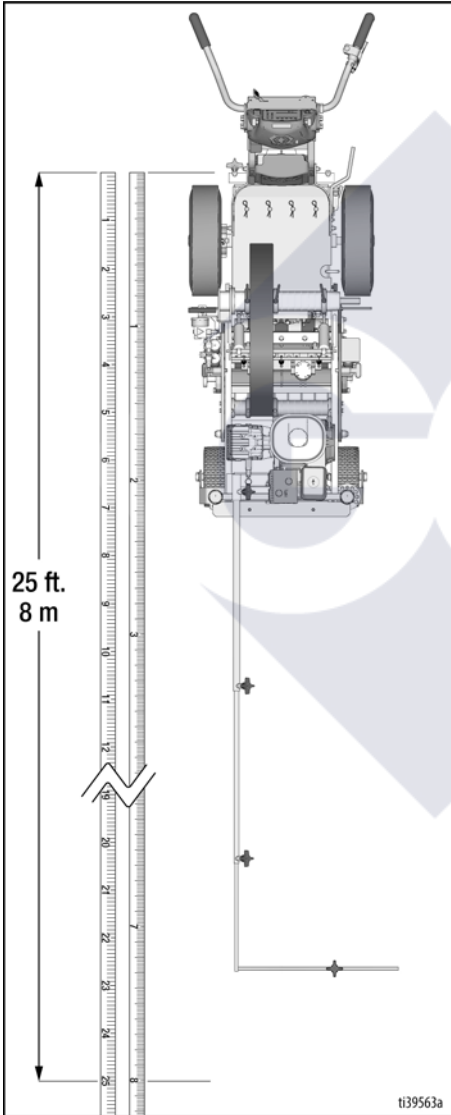

3. Move pointer to rear position.

4. Press to select SETUP/INFO.

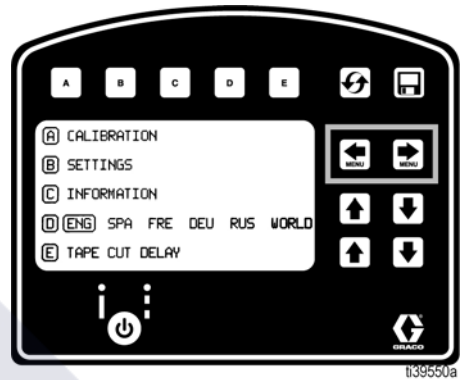

5. Press **A** for Calibration. Set TRAVEL DIST to 24 ft (7 m) or longer. Longer distances ensure better accuracy, depending on conditions.

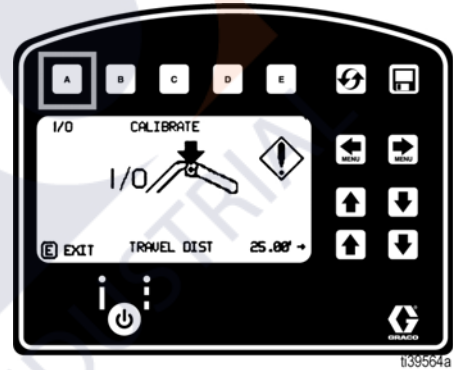

6. Set guide and align with one foot mark on steel tape, as shown in picture.

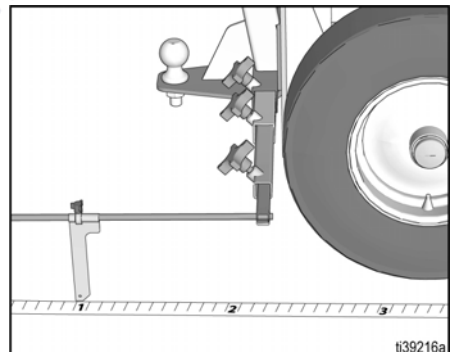

Setup/Startup

7. Press and release tape application button to start calibration.

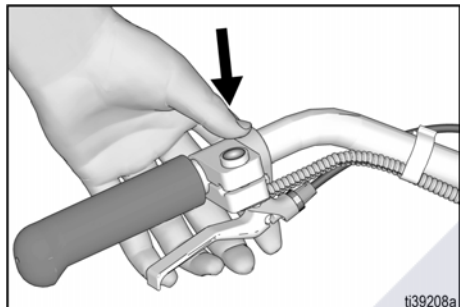

10. Press and release tape application button to complete calibration.

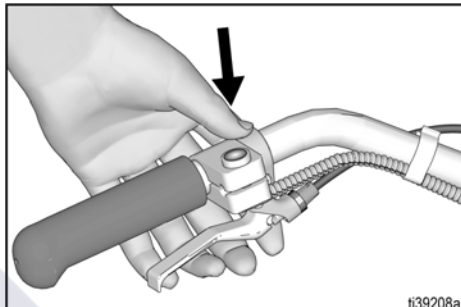

8. Move TapeLazer forward. Keep guide on steel tape.
9. Stop when guide aligns with 25 ft mark on steel tape (a total traveled distance of 24 ft.), or to whatever distance you entered on the screen.

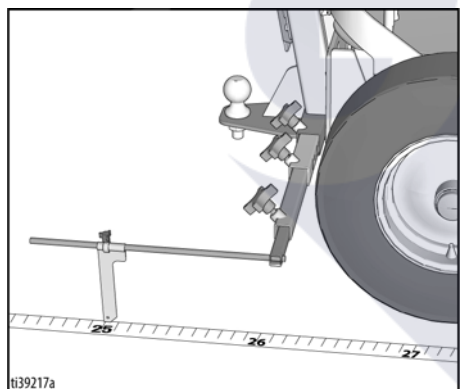

NOTE: Calibration is **NOT** complete when the exclamation symbol \diamond is displayed.

NOTE: Calibration is finished when the check mark symbol \checkmark is displayed.

11. Calibration is now complete.

Operation

Modes of Operation

The method used to apply tape is set by the combination of the **TAPE LINE TYPE** setting and the **MODE** setting. Once both are set via the display, tape application is started and stopped with the tape application button mounted on the handlebar.

Notes:

- If the carriage is in the UP position, the control will not allow taping to start.
- The lengths of skips and spaces are set on the Tape Skip and Space Lengths striping screen. Preset lengths can be selected by pressing the 'A', 'B', or 'C' button. New presets can be saved by pressing and holding the preset buttons.
- Semi-Auto and Skip is the most commonly used mode of operation and is recommended for majority of applications.
- Unit can begin laying with a space instead of a line, if desired. This can be accessed in the Settings Menu.
- CUT DELAY – the end of each skip can be adjusted if necessary to correct for mechanical variations that cause a discrepancy between the programmed skip length and the actual length of tape placed on the road. To adjust Cut Delay, see, **Cut Delay**, page 33. Note that in AUTO mode, the corresponding space distance is also adjusted to maintain the set cycle length (sum of the skip and space lengths).
- Discrepancies with line length accuracy, especially in AUTO MODE, can be improved by adding weight in the on-board payload compartment between the rear axle. **DO NOT** add weight to the front of the TapeLazer, as this will cause the rear tire to lose connection to the pavement causing loss of wheel sensor accuracy.
- Refer to LazerGuide manual (3A5294) for installation and operating instructions if using the LazerGuide instead of the mechanical pointer.

Tape Line Type (Press for solid and hold for skip)			
Solid	Skip		
Press the tape application button once to start applying a continuous line of tape, press again to cut.	Press the tape application button once to lay a single skip of a designated length.	Semi-Auto	Mode (Press “D” button to cycle through modes)
Press the tape application button once to start applying a continuous line of tape, press again to cut.	Press the tape application button once to start applying the set skip-space cycle. Press tape application button again to end cycle.	Automatic	
Press and hold the tape application button to lay a continuous line of tape. Release tape application button to cut.	Press and hold the tape application button to start applying the set skip-space cycle. Release tape application button to end cycle.	Manual	

Tape Application Assembly Positions

The Tape Application Assembly uses three positions during operation. These positions may be relevant when operating, repairing, or assessing the TapeLazer.

In addition, the TapeLazer Carriage uses two positions during operation, raised and lowered. These positions may be relevant when operating, repairing, or assessing the TapeLazer.

Application Position

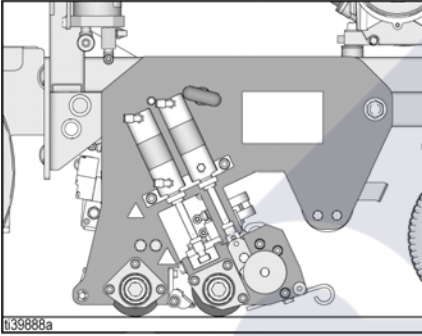

Carriage Raised

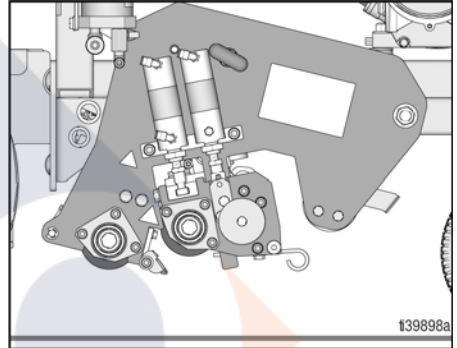

Secondary Position

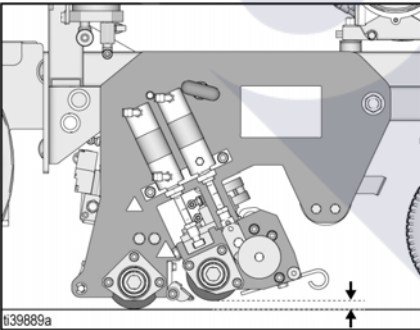

Carriage Lowered

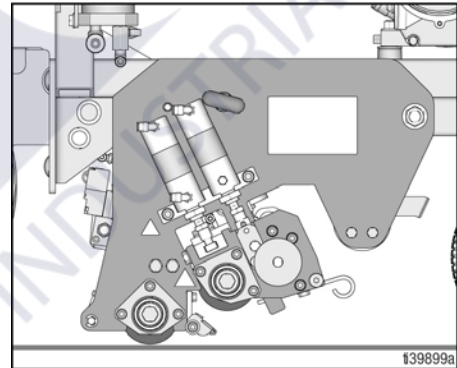

Cut Position

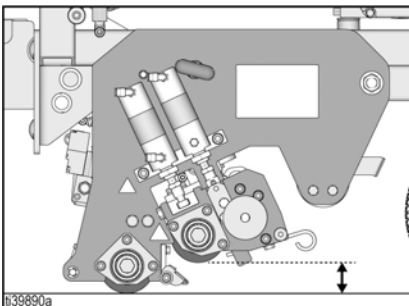

TapeLazer LiveLook Display

SKIP LINE PRESETS AND SELECTION BUTTONS

To save favorite presets, enter Tape and Space lengths with the Adjustment Arrows. Then press and hold A, B, or C to enter that value into favorites. These work just like favorites on a car radio, with a single press to select a favorite.

STRIPING SCREEN

- Cycle through:
- System Delay
 - Tape Skip and Space Lengths
 - Tape Width and Type

TAPE TRIGGER BUTTON OPTIONS

- S**= Press for 1 skip in SKIP MODE (Semi-Auto)
- A**= Press the button to TAPE, press again to STOP (Auto)
- M**= Hold the button to Tape, release to stop (MANUAL)

RESET Trip Distance, Erase Jobs

JOB LOGGING

MENU
Cycle through Menu Screens

CONTROL ADJUSTMENTS
Adjustment Arrows

TAPE LINE TYPE BUTTON OPTIONS

- Press Power Button to choose SOLID LINE
- Press to turn off
- Press and hold Power Button for 1 second to choose SKIP LINE

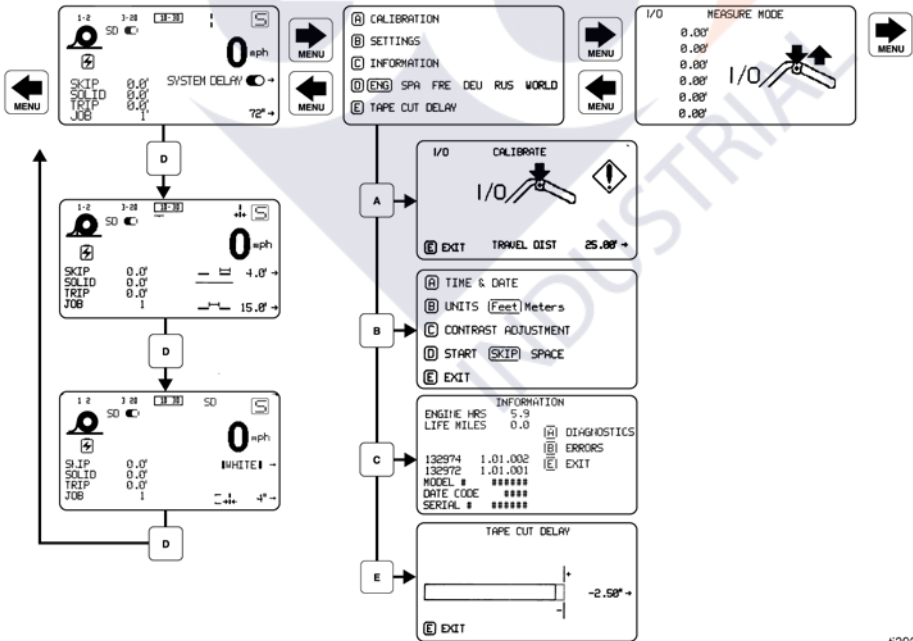
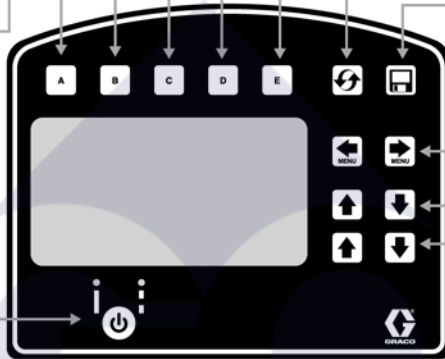

t39211a

Applying Tape

1. Start engine, see **Engine Start**, page 19.
2. Close air drain valve, as shown, to pressurize the system.

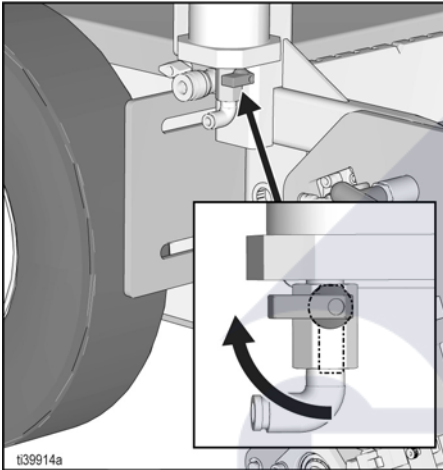

3. Unlock the locking pins on both sides of the carriage.

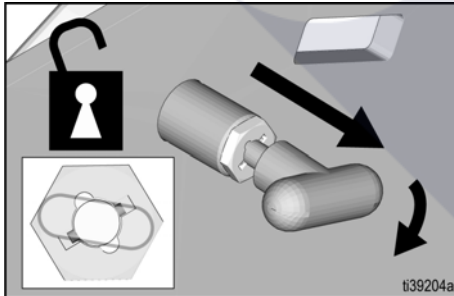

4. Press the carriage raise/lower and engine stop button to lower the carriage.

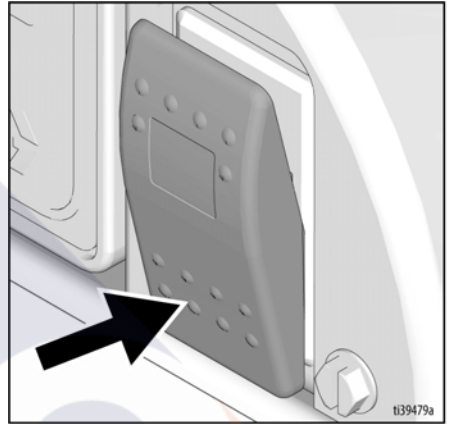

5. Move forward and press tape application button to start applying tape.

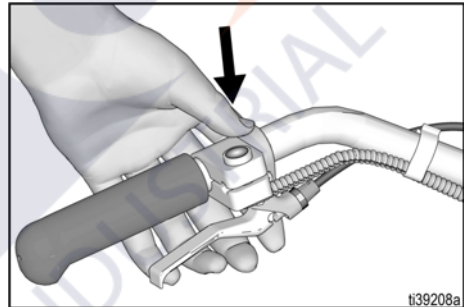

System Delay

System Delay (SD) improves tape placement accuracy by allowing the operator to look forward at the line guide mechanism, important for maintaining straight lines. With **System Delay** turned on, the line guide mechanism becomes the activation point for turning ON and OFF the placement of tape.

Setup System Delay

1. Turn System Delay ON.
2. Extend pointer to preferred distance necessary to achieve long straight lines.
3. Measure the System Delay Distance from the blade to the pointer [A] as shown in the example on the right. Due to the viewing angle from the operator position some amount of adjustment may be necessary to properly view the pointer.

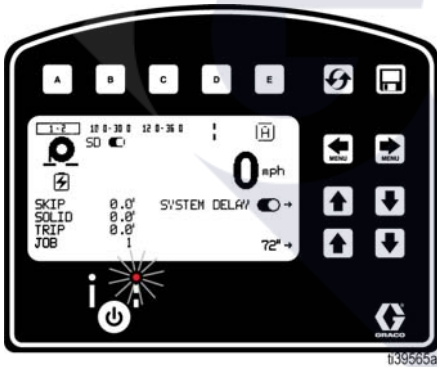

Operating System Delay

1. Turn System Delay ON.
2. With System Delay, the pointer [A] becomes the initiation point for all starts and stops activated by the tape application button.
3. Choose Line Type, SOLID or SKIP. Line Type is indicated by LED after selection.

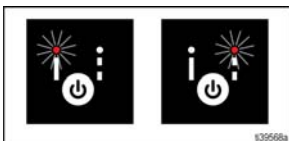

4. Choose Mode: Manual [M], Semi-Auto [S], or Auto [A].
5. Example below, when the pointer [A] reaches start point [B] press (or hold in manual mode) the tape application button. When the pointer reaches the end point [C] press tape application button a second time (or release in manual mode) to end the marking process.

NOTE: After the first button press a progress bar will appear on the display screen showing the delay travel distance. No tape is applied during this travel. In most situations, tape will begin to dispense at the end of this travel (the exception is with the START with SPACE setting). The progress bar will also display after the last button push. At the end of that travel, all taping will stop.

Tape Application Button

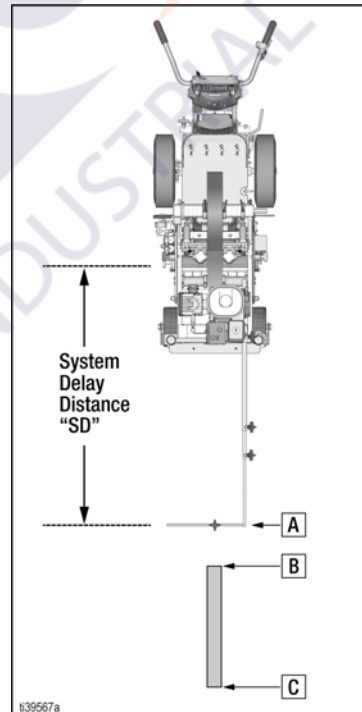
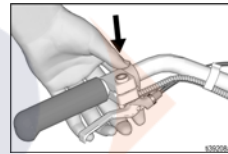

System Delay Example - Semi-Auto Mode/Skip Line

[S] Semi-Auto Mode Skip Line placement using SD example shown: 1 ft intermittent skip, 72 inch System Delay.

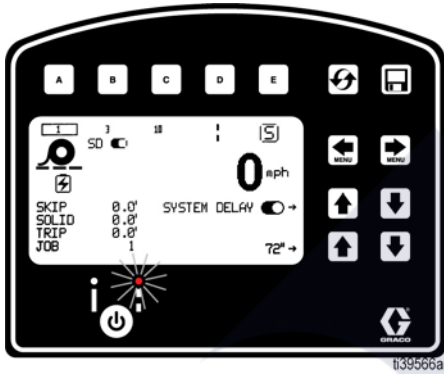

Tape Application Button Activity

Press and RELEASE auto tape application button when pointer [A] reaches the beginning of each line [B]. Each button press produces only one line at the programmed length (1 foot in this example). Repeat for all intermittent lines.

If the button is pressed before the end of the programmed length [C], that line will end at that point, except:

if the pointer is less than 1 foot from the start of the line [B], the button press will be ignored, with a message on the screen. The operator will need to travel further before pressing the button to end the line.

NOTE: The minimum achievable space between intermittent lines is approximately 1 ft. If the button press to start a new line is less than one foot from the end of the previous line that button press will be ignored. The operator will need to travel further before pressing the button to start a new line.

Tape Interrupt

All system delay operation can be canceled by: turning System Delay OFF, turning the LINE TYPE button off (both LEDs off), or double pressing the tape application button.

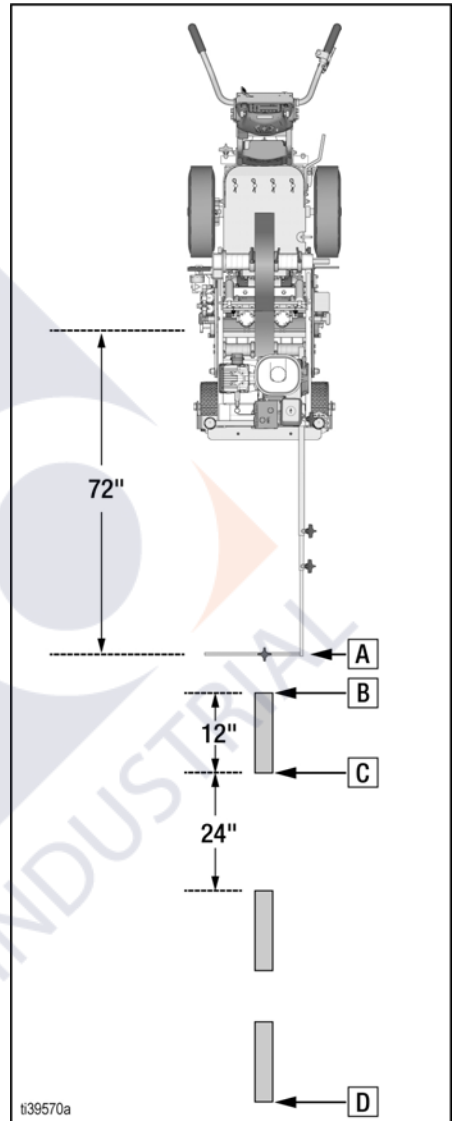

System Delay Example - Auto Mode/Skip Line

[A] **Auto Mode** Skip Line placement using SD example shown: 1 ft line, 2 ft space, 72 inch System Delay.

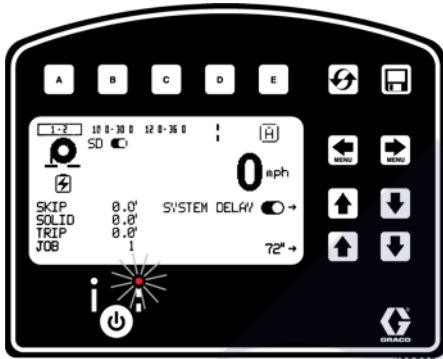

t39565a

Tape Application Button Activity

Press and RELEASE tape application button when pointer [A] reaches start point [B]. Press and RELEASE tape application button a second time after pointer [A] passes ending line [D]. Use this option when the spacing between lines remains consistent.

If the button is pressed before the end of the programmed length [C], that line will end at that point, except:

if the pointer is less than 1 foot from the start of the line [B], the button press will be ignored, with a message on the screen. The operator will need to travel further before pressing the button to end the line.

After pressing the button a second time (either after [D] or before [C]), the operator can press the button again to start another set of skips. However, if the press occurs less than 1' from the previous press, the press will be ignored, with a message on the screen. The operator will need to travel further before pressing the button to start the next skip.

Tape Interrupt

All system delay operation can be canceled by: turning System Delay OFF, turning the LINE TYPE button off (both LEDs off), or double pressing the tape application button.

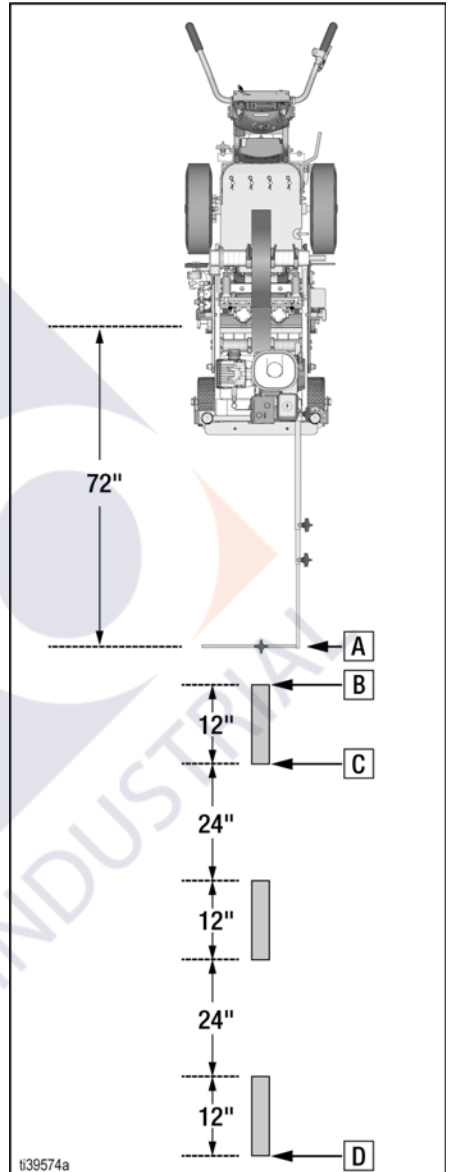

t39574a

Operation

System Delay Example - Manual Mode/Skip Line

[M] Manual Mode Skip Line placement using SD example shown: 1ft line, 2 ft space, 72 inch System Delay.

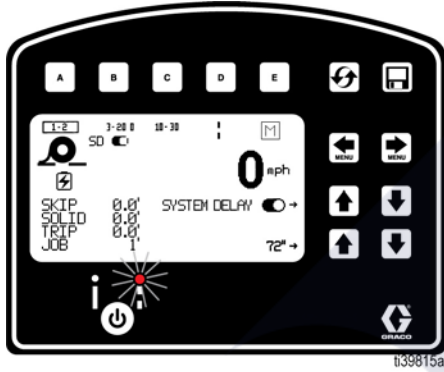

Tape Application Button Activity

Option 1

Press and HOLD tape application button when pointer [A] reaches start point [B]. Release tape application button after pointer [A] passes ending skip line [D]. Use this option when the spacing between lines remains consistent.

Option 2

Press and HOLD tape application button when pointer [A] reaches beginning of skip line start point [B]. Release auto tape control button when pointer reaches end of skip line [C]. Repeat this process for all skip line placement. This is similar to Semi-Auto skip line placement. Use this option when the spacing between lines varies.

Tape Interrupt

All system delay operation can be canceled by: turning System Delay OFF, turning the LINE TYPE button off (both LEDs off), or double pressing the tape application button.

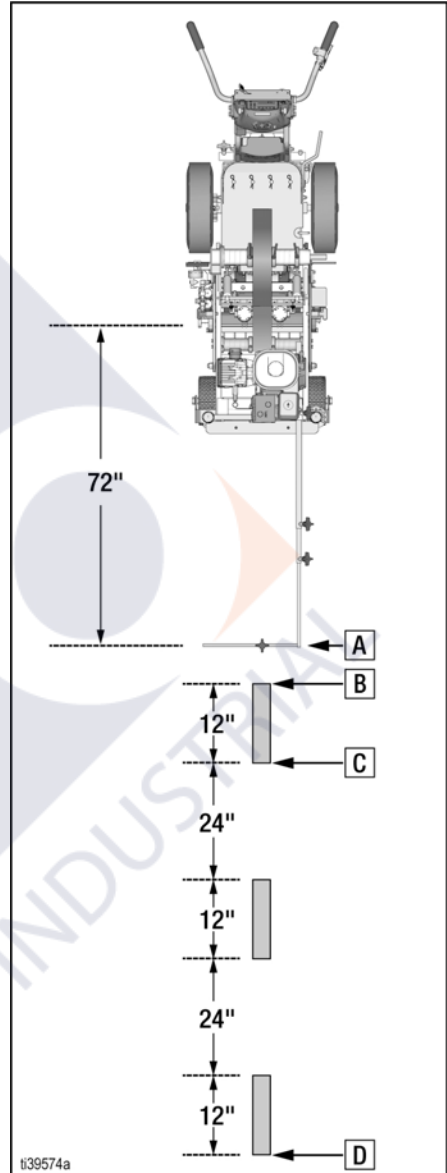

System Delay Example - Semi-Auto and Auto Mode/Solid Line

[S] Semi-Auto Mode and [A] Auto Mode
 Continuous Line placement using SD Example
 shown: 72 inch System Delay.

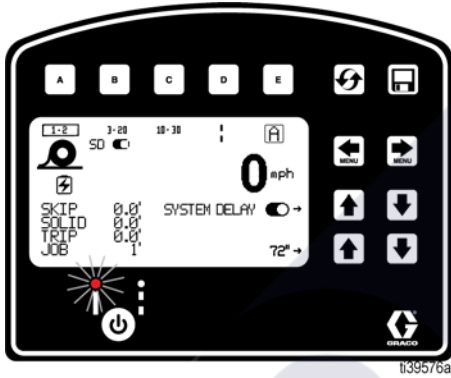

Tape Application Button Activity

NOTE: SEMI-AUTO MODE tape application button function for continuous line placement is identical to AUTO MODE.

Press and RELEASE tape application button when pointer [A] reaches start of line [B]. Press and RELEASE auto tape application button a second time at the end of continuous line [D].

Tape Interrupt

All system delay operation can be canceled by: turning System Delay OFF, turning the LINE TYPE button off (both LEDs off), or double pressing the tape application button.

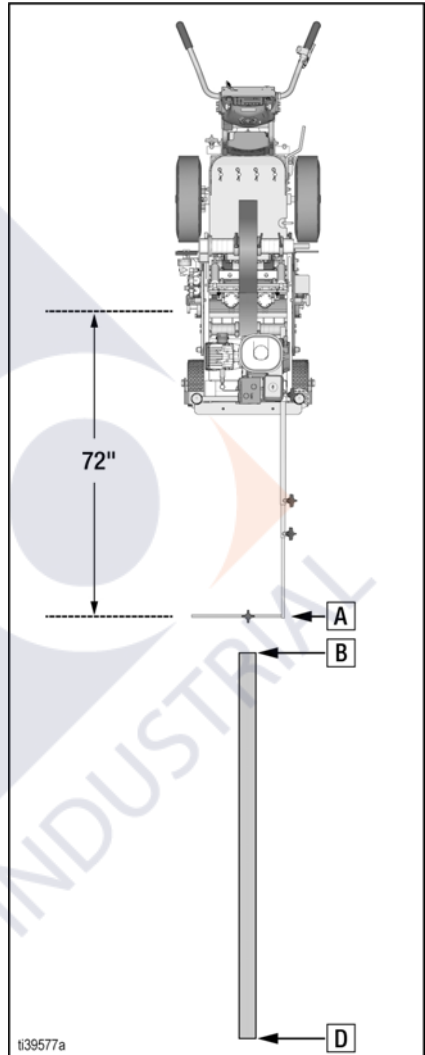

Operation

System Delay Example - Manual Mode/Solid Line

[M] **Manual Mode** Continuous Line placement using SD Example shown: 72 inch System Delay.

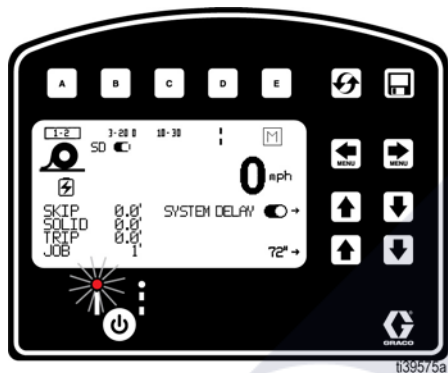

Tape Application Button activity

Press and HOLD tape application button when pointer [A] reaches start of line [B]. Release tape application button at the end of the continuous line [D].

Tape Interrupt

All system delay operation can be canceled by: turning System Delay OFF, turning the LINE TYPE button off (both LEDs off), or double pressing the tape application button.

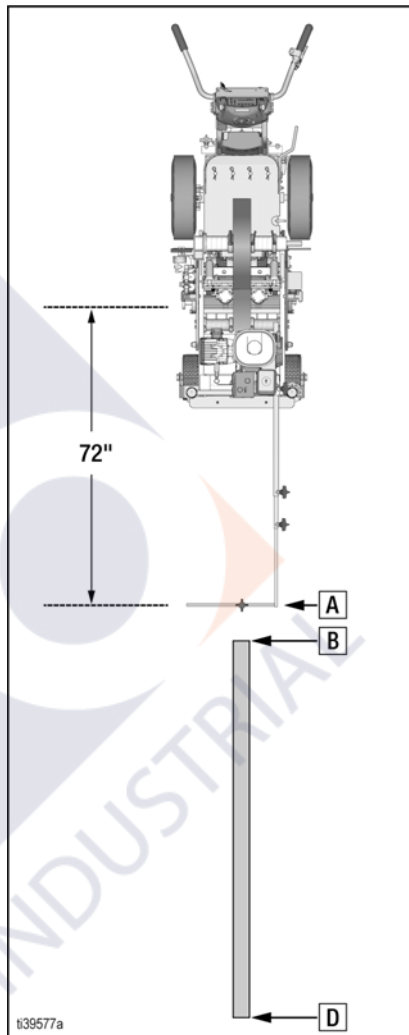

Cut Delay

Cut Delay allows adjustment for correcting discrepancies between the actual tape length placed on the road versus the programmed distance displayed. System mechanical inefficiencies can make this necessary. The factory default is pre-set for best results, but adjustments might be required from time to time.

If the skip line is longer or shorter than the displayed value follow the steps below.

1. Negative Tape Cut Delay (-X) is used when actual tape length is longer than programmed length. Decreasing Tape Cut Delay will reduce tape length.
2. Positive Tape Cut Delay (+X) is used when actual tape length is shorter than programmed length. Increasing Tape Cut Delay will increase tape length.

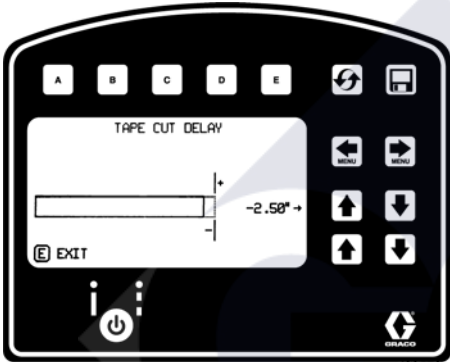

ti39578a

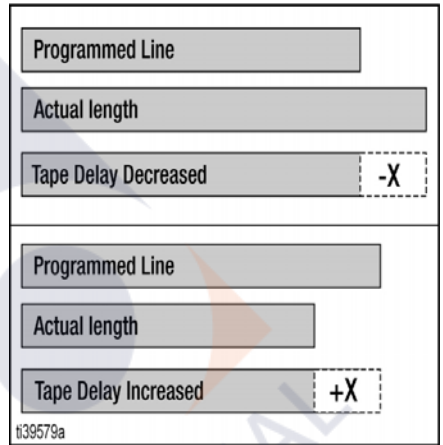



ti39579a

Operation

Measure Mode

Measure Mode can be used in lieu of a tape measure to measure distances when laying out an area to be taped.

1. Press   to select Measure Mode.

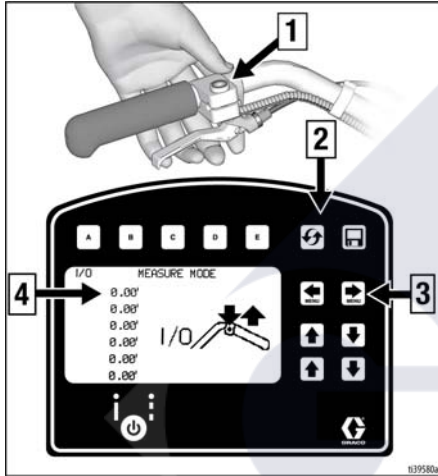

2. Press and release tape application button. Move taper forwards or backwards.

NOTE: Moving backwards displays a negative distance.

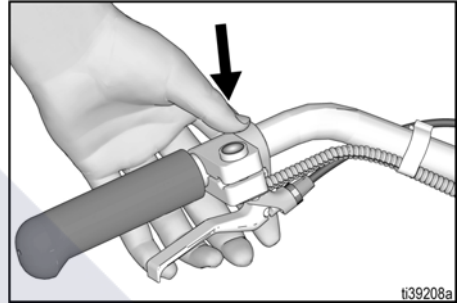

3. Press and release tape application button to end measured length. Up to six lengths are viewable.

Ref.	Description
1	Press to start measurement. Press to stop measurement.
2	Hold to reset values to zero.
3	Scroll between main menu screens.
4	Last measurement taken.

Splicing Tape

1. Halt TapeLazer before tape is finished to prevent tape from rolling off of the spindle and into the lower rollers.
2. Peel remaining tape from roll and prevent it from becoming dirty or otherwise compromised.

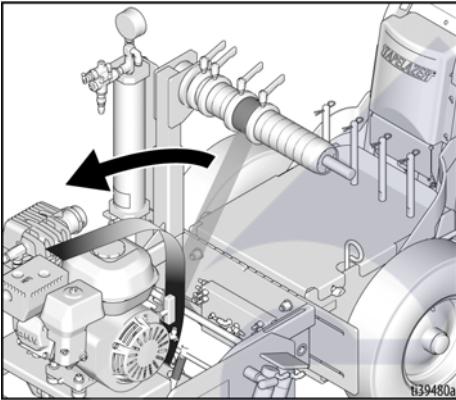

3. Install new tape on tape roll spindle, see **Loading Tape**, page 10.

4. Peel end of the tape from the new roll and match the ends of each tape roll. Apply splicing tape to tape seam.

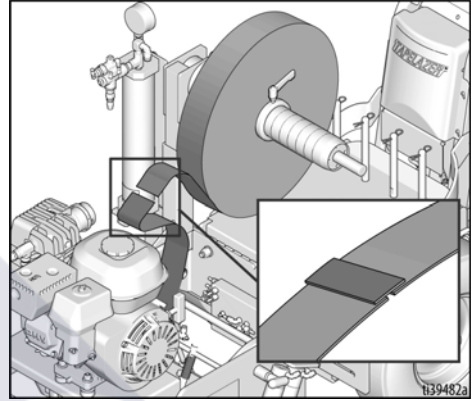

5. Roll tape back onto the spindle to create tension on tape.

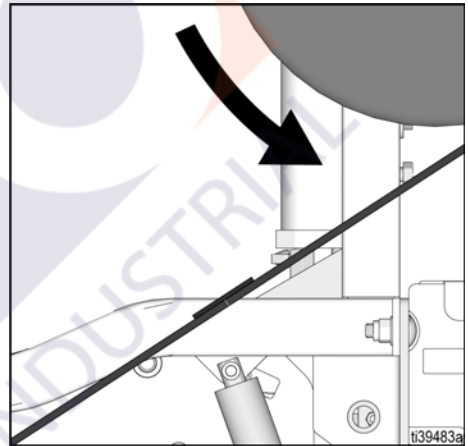

6. Resume taping.

Setup/Information

Use   to select Setup/Information.

See **Universal Symbols Key**, page 65, for explanation of screen symbols.



Press **A** to select Calibration.

See **Calibration**, page 21.

Press **B** to select Settings.

See **Settings**, page 37.

Press **C** to select Information.

See **Information**, page 38.

Press **D** to select Language.

See **Language**, page 20.

Press **E** to select Cut Delay.

See **Cut Delay**, page 33.

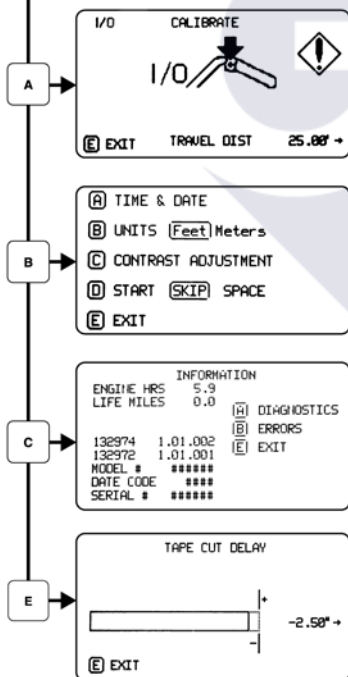

ti39584a

Settings

Use   to select Setup/Information.

Press **B** to open Settings Menu.

See **Universal Symbols Key**, page 65, for explanation of screen symbols.

Press **A** to open Time and Date.

Set Time and Date on this screen. This is needed for accurate Data Logging.

Press **B** to set Units as feet or meters.

Press **C** to set Contrast Adjustment.

Adjust screen contrast to desired value.

Press **D** to choose start programmed lines with Skip or Space.

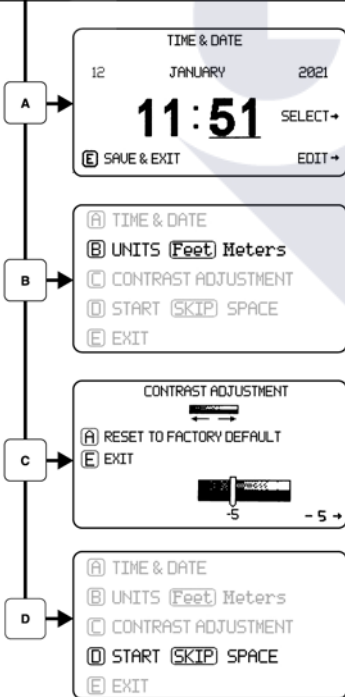

ti39585a

Operation

Information

Use   to select Setup/Information.

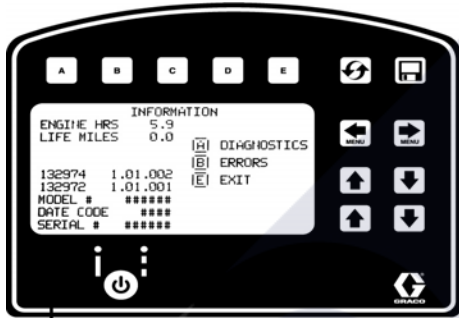

Press [C] to access information.

See **Universal Symbols Key**, page 65, for explanation of screen symbols.



Press  to open Diagnostics.

These screens are used to view and test functionality of components.

Press  to cycle forward to diagnostic screen #2 and screen #3, and  to cycle back to diagnostic screen #1

Diagnostic screens #2 and #3 display alternator, battery, and charger information, and provide a live look at which outputs are operating properly, or are open/short. Diagnostic screen #3 displays each output's approximate current and duty cycle.

Control board outputs affect the following solenoids, as referenced by label on solenoid assembly, see **Air Line Schematic**, page 62 and **Solenoid Locations on Control Board**, page 48.

Control Board Output	Connected Solenoids
1	1, 2, 5, 6
2	3
C	4

Press  to open the error screen.

This screen tracks the number of occurrences and the time/date of the most recent open/short.

If errors are encountered, refer to **Troubleshooting**, page 43.

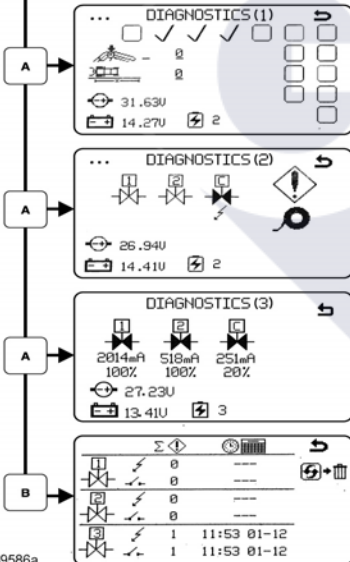

t139586a

Data Logging

The TapeLazer control is equipped with Data Logging, which allows the user to recall job data and export the data from the machine to a USB drive.

See **Universal Symbols Key**, page 65, for explanation of screen symbols.

Press the  to open the Data Logging pop up window.

Choose to start recording a new job or view jobs previously done.

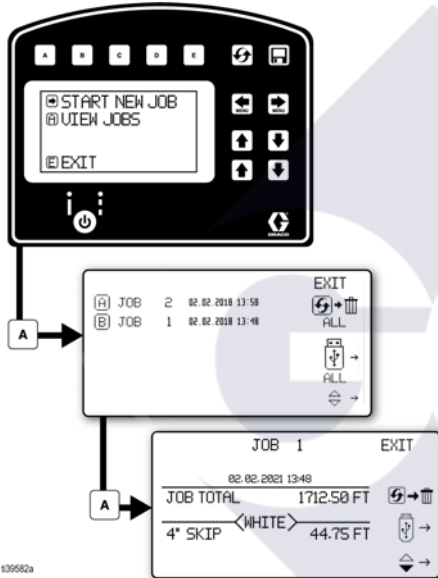

 Start recording a new job.

 Erase all jobs.

 Export all jobs to USB.

 Erase displayed job.

 Export job to USB.

Job data is compiled while taping. It keeps track of distance taped, tape color, and line width, but tracks skips and solids separately.

Maintenance

Periodic Maintenance

DAILY: Check engine and compressor oil level and fill as necessary.

DAILY: Check hoses for wear and damage.

DAILY: Check pressure drain valve for proper operation.

DAILY: Check and fill gas tank.

DAILY: Verify calibration.

AFTER THE FIRST 20 HOURS OF OPERATION: Drain engine oil and refill with clean oil. Reference Honda Engines Owner's Manual for correct oil viscosity.

WEEKLY: Remove engine air filter cover and clean element. Replace element, if necessary. If operating in an unusually dusty environment: check filter daily and replace, if necessary.

Replacement elements can be purchased from your local HONDA dealer.

AFTER EACH 100 HOURS OF OPERATION: Change engine oil. Reference Honda Engines Owner's Manual for correct oil viscosity.

SPARK PLUG: Use only BPR6ES (NGK) or W20EPR-U (NIPPONDENSO) plug. Gap plug to 0.028 to 0.031 in. (0.7 to 0.8 mm). Use spark plug wrench when installing and removing plug.

Air Compressor

Before operation, ensure oil is visible on threads of fill port. If not full, fill with oil until visible on threads.

NOTICE

Failure to properly fill compressor with oil can result in severe or catastrophic damage to the compressor.

To check oil level:

1. If unit is equipped with drain plug, remove drain plug and verify oil is visible on threads of drain port. If not full, fill with oil through drain port until visible on threads.
2. If unit is equipped with sight glass, verify oil level is above red dot. If not, remove oil breather and fill with oil through breather port until level is above red dot.

NOTE: Oil level will change at slower rate than poured as it makes its way into the crankcase. Pour small amounts at a time, checking between pours.

Routine maintenance is important to ensure proper operation of your compressor.

Maintenance includes performing routine actions to keep your compressor in operation and prevent trouble in the future.

Activity	Interval
Replace air filter	Every 200 hours, or as needed.
Change oil*	After first 50 hours, then every 200 hours or every three months.

*Drain oil by siphoning from drain port. Use approximately 4 fl. oz. of SAE 30W air compressor oil. If equipped with a drain plug, proper oil level is attained when oil is visible on threads of drain port. If equipped with a sight glass, proper oil level is attained when oil is above red dot.

Blade Replacement

			
<p>To help prevent serious injury from cutting, wear gloves when handling the cutting blade.</p>			

1. Perform pressure relief procedure, see **Pressure Relief Procedure**, page 7.
2. Using a 1/4 in. Allen wrench, remove bolt holding blade in place from either side of the TapeLazer.

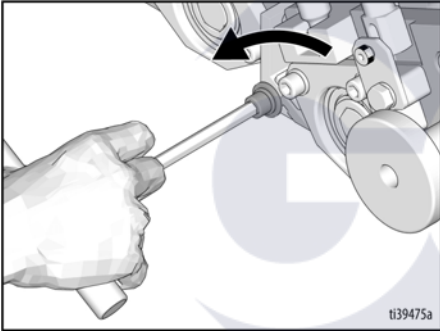

3. Gently pull blade to remove it.

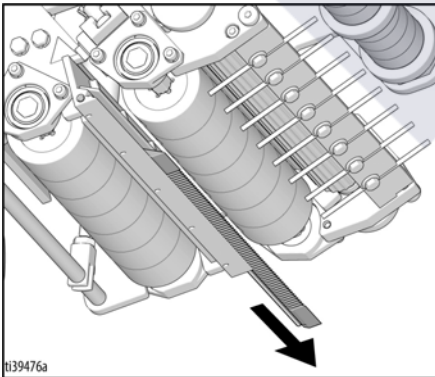

4. Install new blade into place.

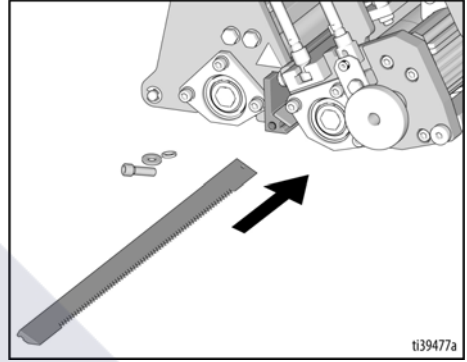

5. Using a 1/4 in. Allen wrench, reinstall bolt and washers holding blade in place.

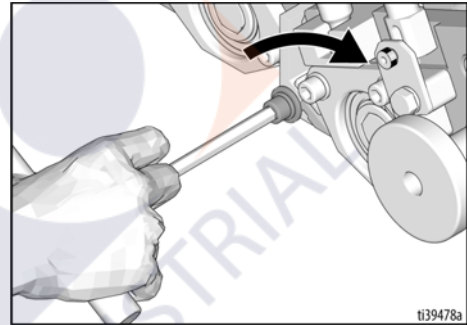

NOTE: Blade may become stuck from rust or debris. If blade is stuck, remove bolt on opposite side of the unit and place new blade against the old one. Using a hammer, gently tap new blade into place, pushing the old blade out the opposite side.

Brake Removal and Replacement



To help prevent injury, install the blade guard or remove blade prior to adjusting rollers.

1. Perform pressure relief procedure, see **Pressure Relief Procedure**, page 7.
2. Remove two pins holding brake in place. Set aside to reuse.

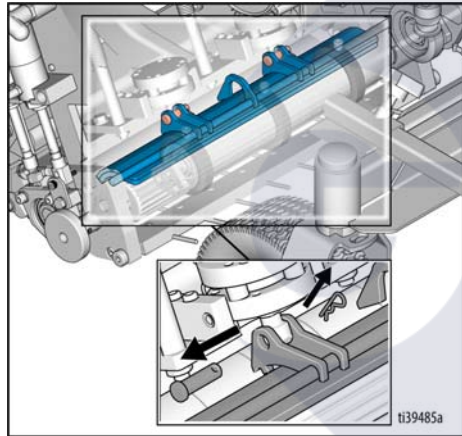

3. Using a 1/4 inch Allen wrench, remove four bolts and washers (two on each side).

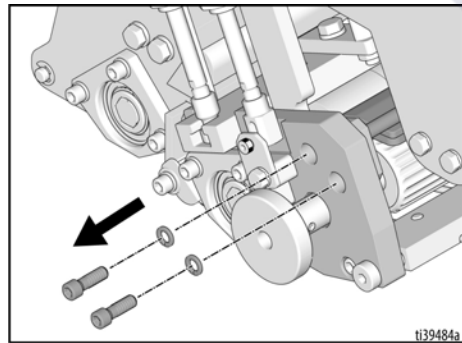

4. Pivot brake forward and remove.

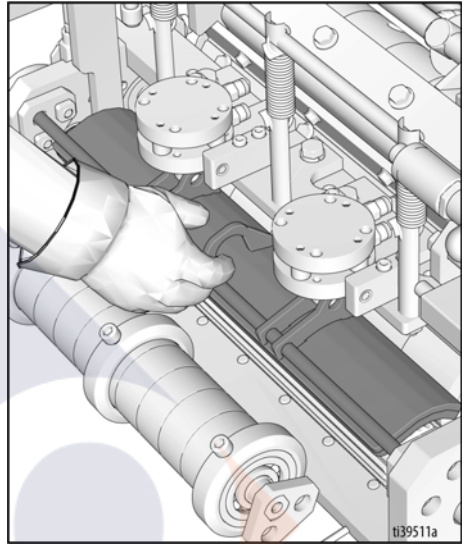

5. Replace brake and re-attach four bolts and washers.
6. Replace pins.

Troubleshooting

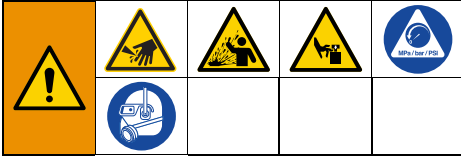

1. Follow **Pressure Relief Procedure**, page 7, before checking or repairing unit.

Problem	Cause	Solution
Engine won't start.	Engine switch is OFF.	Turn engine switch ON.
	Engine is out of gas.	Refill gas tank. Refer to Honda Engines Owner's Manual.
	Engine oil level is low	Try to start engine. Replenish oil, if necessary, see Maintenance , page 40. Honda Engine Owner's Manual.
	Spark plug cable is disconnected or damaged.	Connect spark plug cable or replace spark plug.
	Cold engine.	Use choke.
	Fuel shutoff lever is OFF.	Move lever to ON position.
Oil is seeping into combustion chamber.		Remove spark plug. Pull starter 3 to 4 times. Clean or replace spark plug. Start engine. Keep TapeLazer upright to avoid oil seepage.
Engine rope is difficult to pull, making engine starting hard.	Air pressure in the cylinder makes it harder to pull-start the engine.	Relieve air pressure, see Pressure Relief Procedure , page 7.
High engine speed at no load.	Mis-adjusted throttle setting.	Reset throttle to 3000 engine RPM at no load.
	Worn engine governor.	Replace or service engine governor. Refer to Honda Engines Owner's Manual.
Distance not adding properly (measure mode and speed will be inaccurate.)	Unit is not calibrated.	Re-calibrate unit. See, Calibration , page 21.
	Pavement is uneven and rear right tire is not remaining on pavement when applying tape.	Add weight to the back of the TapeLazer. There is an area under the spare roller storage area for this purpose.
		Remove segment(s) of application and/or taping roller(s) to match width of tape. See Roller Adjustment , page 11.
Blade doesn't cut tape or provides poor cuts.	Blade guard is attached.	Remove blade guard from blade.
	Blade is dull or worn.	Replace blade.
	No or low air pressure.	Pressurize unit. Verify system is achieving full pressure. Check for air leaks or damaged air lines and cylinders. See Air Cylinder Internal Leaks , page 50
	Brake is worn.	Replace brake.
	Low system pressure.	Check for leaks.

Troubleshooting

Problem	Cause	Solution
Unit won't activate (application roller will not drop down).	Tape line type not selected.	Select "solid" or "skip" tape line type, see Modes of Operation , page 23.
	Carriage is in the raised position.	Lower carriage. See Tape Application Assembly Positions , page 24, for information on carriage positions.
	Low system pressure.	Check for air leaks, see System is not holding pressure/not generating pressure , page 49.
	Mechanically jammed.	Check for obstructions in taping application assembly.
	Solenoids damaged.	Check solenoids and replace if necessary. Refer to unit error screen. See Information , page 38 and Solenoid Manifold Operation , page 46.
Tape is spooling off roll too fast.	Tape roll not tensioned properly.	Press tape collar (with red tension ring) into the tape roll prior to tightening clamp.
	Taping too fast.	Slow down.
Actuates, but won't deploy tape.	Tape is not fed far enough through the rollers.	Ensure tape is sticking down appropriate distance. See Loading Tape , page 10.
	Inlay groove too deep.	Adjust rollers to fit into groove. See Roller Adjustment , page 11.
	Tape is curled in front of guide rods.	Adjust guide rods back, see Carriage Applicator Parts , page 56.
Control board and display will not start up (red LED on control board not flashing while engine is running).	No power to board.	With engine running, check voltage to control board at red and red/white wires. See Wiring Diagram , page 64. If voltage is present, replace board. If no voltage, check for voltage from gray engine leads where red and white/red wires connect. If not voltage there, consult Honda engine owner's manual. If voltage exists there, replace wiring harness.
	Control board faulty.	
	Wiring harness is faulty.	
Will not lay tape.	Carriage is in the raised position.	Release carriage locking pins and pivot carriage down. See Tape Application Assembly Positions , page 24, for information on carriage positions.
	Tape line type not selected.	Select solid or skip line. See Modes of Operation , page 23.
Control display is blank, will not light up.	Bad connection between control display and control board.	Check for loose or faulty connection between control board and control display.
		Replace control display.
Engine stop switch will not kill engine.	Red connector tapped to engine line is disconnected.	Check for good connection to black engine wire, see Wiring Diagram , page 64.
	Unit not grounded.	Check for proper grounding from engine to frame, see Wiring Diagram , page 64.
No button response.	Tape application button not connected.	Check for faulty connection. Replace button if necessary.
Unit actuates, but there is no secondary position.	Control board output #2 is open.	Check for faulty connection to main board and any broken wires. Replace solenoid if necessary. Refer to unit error screen, see Information , page 38.

Problem	Cause	Solution
Unit does not stabilize between 125 and 145 psi.	Unloader valve is broken.	Replace unloader valve.
No battery voltage.	Charging board is disconnected.	Check charging board connection. If necessary, replace charging board.
Will not actuate tape application assembly.	Control board output #1 is open.	Check for faulty connection(s). Replace solenoid assembly if necessary. Refer to unit error screen. See Information , page 38 and solenoid troubleshooting (above).
	Control board output#1 is shorted.	
	Control board output # 2 is shorted.	
Will not actuate tape application assembly, shows solenoid #1 and #2 are open.	Battery is unplugged/fuse is blown.	Check fuse. Replace if necessary. If battery is suspect, restart unit and try to actuate the TapeLazer tape application assembly. Unit will detect a bad battery.
Will not count distance.	Distance sensor is not connected.	Diagnose in measure mode. Check for faulty connections. Replace distance sensor if necessary.
Will not lower carriage.	Mechanical lock(s) engaged.	Disengage the mechanical lock(s).
	Control board output # 3 is shorted.	Check for faulty connection. Replace solenoid if necessary. Refer to unit error screen. See To Check if Solenoids are Functioning Properly , page 49.
	Control board output #3 is open.	
	Tape carriage button is not connected.	Check for faulty connection. Replace switch if necessary.
Will not pressurize.	Relief valve on unloader valve is flipped open.	Flip to closed.
	Air hose leaks.	Find leak and replace hose or tighten connection(s).
	Solenoid leaks.	Double check air cylinders to make sure there is not an internal leak. See Air Cylinder Internal Leaks , page 50. If not, replace solenoid manifold.
	Cylinder leaks.	Replace cylinder.
	Loose air connection(s).	Tighten connection(s).
	Compressor failure/not spinning.	Verify compressor is spinning while engine is running. If not, replace compressor.
	Pressure relief valve is open.	Close valve.
Will not recognize a USB or charge.	USB board is not connected.	Check for faulty connection. Replace USB board if necessary.
Will not show system pressure.	Pressure gauge is broken.	Replace gauge.

Troubleshooting

Solenoid Manifold Operation



To help prevent injury from moving parts, keep clear of carriage when actuating solenoid outputs. Perform **Pressure Relief Procedure**, page 7, before working on equipment.

To diagnose a malfunctioning unit, begin with diagnostics, see **Information**, page 38.

Cycle to Diagnostic Screen #2 to assess what condition your unit is in.

Reference the table conditions and screens below to determine the operating condition. Note, the unit must be running and pressurized.

Operating Condition #	Output '1'	Output '2'	Output 'C'	Description
#1	Off	Off	Off	Tape application assembly is in cut position. Carriage is in the raised position
#2	Off	Off	On	Tape application assembly is in cut position. Carriage is in the lowered position
#3	On	On	On	Tape application assembly is in application position. Carriage is in the raised position
#4	On	Off	On	Tape application assembly is in secondary position. Carriage is in the raised position

Operating Condition #1

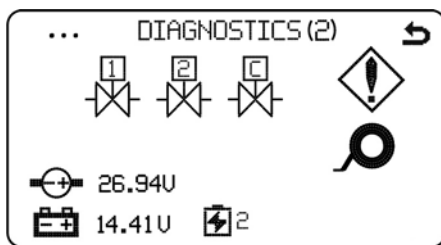

i39893a

Tape application assembly is in cut position. Carriage is in the raised position, see **Tape Application Assembly Positions**, page 24.

Output '1' = OFF

Output '2' = OFF

Output 'C' = OFF

Operating Condition #2

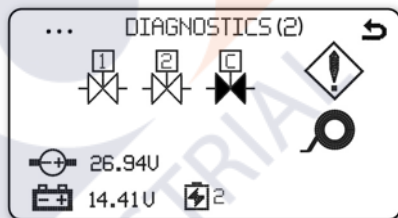

i39902a

Tape application assembly is in cut position. Carriage is in the lowered position, see **Tape Application Assembly Positions**, page 24.

Output '1' = OFF

Output '2' = OFF

Output 'C' = ON

Operating Condition #3

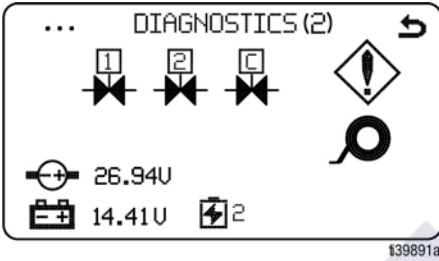

Tape application assembly is in application position. Carriage is in the raised position, see **Tape Application Assembly Positions**, page 24.

Output '1' = ON

Output '2' = ON

Output 'C' = ON

Operating Condition #4

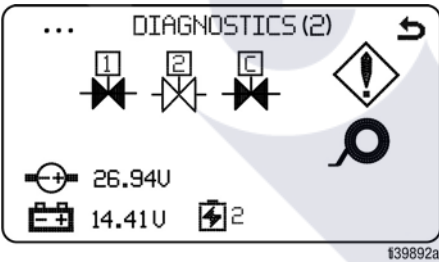

Tape application assembly is in secondary position. Carriage is in the raised position, see **Tape Application Assembly Positions**, page 24.

Output '1' = ON

Output '2' = OFF

Output 'C' = ON

Notes:

1. To energize solenoid outputs '1' and '2', press the tape application button once.
2. To energize solenoid output '1' by itself, press the tape application button twice.
3. To energize solenoid output 'C', use the carriage raise/lower switch.
4. To energize outputs '1' and '2' either solid or skip line must be selected and highlighted red on the display.

If unit does not function as described above, check the following:

1. Mechanical jam. Check to make sure there is no obstruction or binding that is restricting movement. Make sure that the carriage locking pins are in the retracted position.
2. Wiring is incorrect. Check **Wiring Diagram**, page 64.
3. Air line routing is incorrect. Check **Air Line Schematic**, page 62. When connecting air lines follow the **Air Line Connection Sequence**, page 63.
4. Unit has a short circuit. See **Diagnosing a Short Circuit**, page 48.
5. Unit has an open circuit. See **Diagnosing an Open Circuit**, page 48.
6. Solenoids are not functioning properly. See **To Check if Solenoids are Functioning Properly**, page 49.

Troubleshooting

Diagnosing a Short Circuit

1. A short can be the result of two faulty components: faulty solenoid manifold or faulty control board.
2. Unplug all solenoid manifold wires connected to control board outputs '1', '2', and 'C', see **Solenoid Locations on Control Board**, page 48.
3. Navigate to Diagnostics Screen #2 on control display, see **Information**, page 38.
4. Actuate outputs '1', '2', and 'C', see the **Notes:**, page 47, under **Solenoid Manifold Operation**, page 46.
5. If the control board is still registering a short, the board is bad and needs to be replaced. If the control board is now registering an open, the solenoid manifold is bad and needs to be replaced.

Diagnosing an Open Circuit

1. An open can be the result of two faulty components: faulty solenoid manifold, or faulty control board.
2. Unplug all solenoid manifold wires connected to control board outputs '1', '2', and 'C', see **Solenoid Locations on Control Board**, page 48.
3. Navigate to Diagnostic Screen #2 on control display, see **Information**, page 38.
4. Actuate outputs '1', '2', and 'C', see the **Notes:**, page 47, under **Solenoid Manifold Operation**, page 46.
5. Measure the DC voltage across the three solenoid outputs:

Without Solenoids Connected

Control Board Output '1' Reading	Control Board Output '2' Reading	Control Board Output 'C' Reading
13.5 +/- 1 VDC	13.5 +/- 1 VDC	16-34 VDC

Without Solenoids Connected

Control Board Output '1' Reading	Control Board Output '2' Reading	Control Board Output 'C' Reading
13.5 +/- 1 VDC	13.5 +/- 1 VDC	16-34 VDC

6. If control board voltages are in this range, the control board is good. The solenoid manifold needs to be replaced.
7. In the Diagnostics Screen #3, check the amperage of the three solenoid outputs using the diagnostics screen, see **Information**, page 38.

Minimum Amps with Solenoids Connected

Control Board Output '1' Reading	Control Board Output '2' Reading	Control Board Output 'C' Reading
1850 mA	--	--

8. If any of the outputs are reading lower than shown in the table, there is an open in the solenoid manifold and it must be replaced.

Solenoid Locations on Control Board

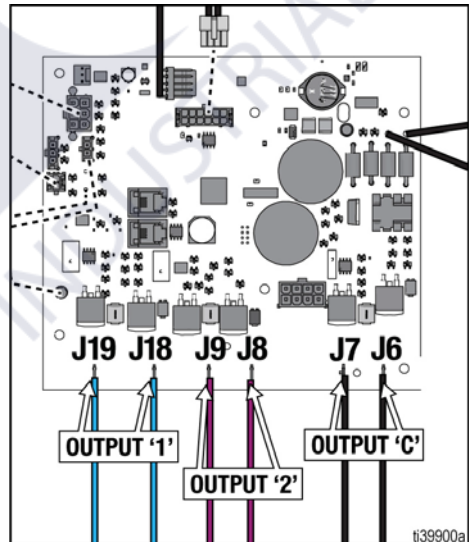

To Check if Solenoids are Functioning Properly

1. Run unit in diagnostics screen under the following conditions, see **Information**, page 38.

Output '1'	Output '2'	Output 'C'	Ports to unplug and check
Off	Off	Off	1, 2, 3, 4, 5, 6
On	On	On	7, 8, 9, 10, 11

2. Checked ports should not have any air flowing from them. If they do, the solenoid manifold is not functioning correctly and may need to be replaced. Try to shift the solenoid by depressing the 'manual shift button' to dislodge a stuck valve. If that does not work, the solenoid manifold must be replaced.

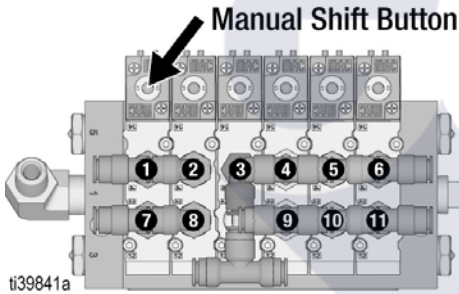

System is not holding pressure/not generating pressure

This indicates that there is a leak in the system. This procedure details how to find and fix the leak.

NOTE: The system will bypass air through unloader valve once at 145 psi.

1. Check main pressure relief valve to make sure it is closed and not leaking air.
2. Check pressure relief lever on the unloader valve to make sure it is in the closed position and not leaking air.

3. Run unit to determine if the air compressor is outputting air. Open the pressure relief valve to check for air flow. Also look for the compressor fan to be in motion while the unit is running.
 - a. **Compressor is outputting air:** there is a leak elsewhere in the system. Proceed with step 4.
 - b. **Compressor is not outputting air:** compressor has failed. Replace compressor and follow recommended maintenance intervals to prevent future failure.
4. Close off system by turning pressure relief valve shut and check for external leaks. There should be no air leaking out of any external piece of the equipment, besides the unloader valve. Potential leak points to check:
 - a. Air lines: If an air line is damaged (kinked, torn) replace with replacement tube and install properly to avoid future damage and kinking. If air lines are loose from the push connect fitting, reconnect and ensure that hose marking is flush with push to connect collet.
 - b. Fittings: Damaged fittings will need to be replaced. If a loose fitting is causing the issue, tighten the fitting to stop the leak.
 - c. Manifold Exhaust valves: If air is leaking from exhaust valves on manifold, this is usually indicative of an air cylinder failure, NOT a solenoid failure. Follow procedure outlined below to thoroughly check for air cylinder leaks.

Troubleshooting

Air Cylinder Internal Leaks



To help prevent injury from moving parts, keep clear of carriage when actuating solenoid outputs. Perform **Pressure Relief Procedure**, page 7, before working on equipment.

1. Run unit in Diagnostics Screen #3 in the following conditions (See **Information**, page 38).

NOTE: Unit will actuate while in the diagnostics screen.

2. Perform pressure relief procedure, see, **Pressure Relief Procedure**, page 7.
3. To diagnose air cylinder internal leaks, unplug the air lines connected to the solenoid parts listed in the table below, starting with the top row. See, **Solenoid Ports Reference**, page 51, for port locations.

Output '1'	Output '2'	Output 'C'	Ports to unplug and check
Off	Off	Off	2, 5, 6, 10, 11, 13
Off	Off	On	7,8
On	On	Off	1, 3, 9, 12, 14, 16

4. Close air drain valve.
5. There should be **NO** air flow from air cylinders to these ports. If there is air flow, the cylinder has an internal leak and needs to be replaced. Refer to **Air**

Line Connection Sequence, page 63, when re-connecting air lines.

6. If no airflow is observed, perform pressure relief procedure, see **Pressure Relief Procedure**, page 7.
7. Reconnect air lines disconnected in step 3. Disconnect the air lines in the second row of the table above.
8. Close air drain valve.
9. Actuate control board output 'C', see the **Notes:**, page 47, under **Solenoid Manifold Operation**, page 46.
10. If no airflow is observed, deactivate control board output 'C; and preform pressure relief procedure, see **Pressure Relief Procedure**, page 7.
11. Reconnect air lines disconnected in step 7 and disconnect those in the third row of the table above
12. Close air drain valve.
13. Actuate control board outputs '1', '2', and 'C', see the **Notes:**, page 47, under **Solenoid Manifold Operation**, page 46.
14. If no airflow is observed, deactivate control board output 'C; and preform pressure relief procedure, see **Pressure Relief Procedure**, page 7.
15. Reconnect air lines disconnected in step 11.
16. If there are no leaks on any of the ports, then there is an internal leak inside the solenoid manifold, and the solenoid manifold will need to be replaced.

Solenoid Ports Reference

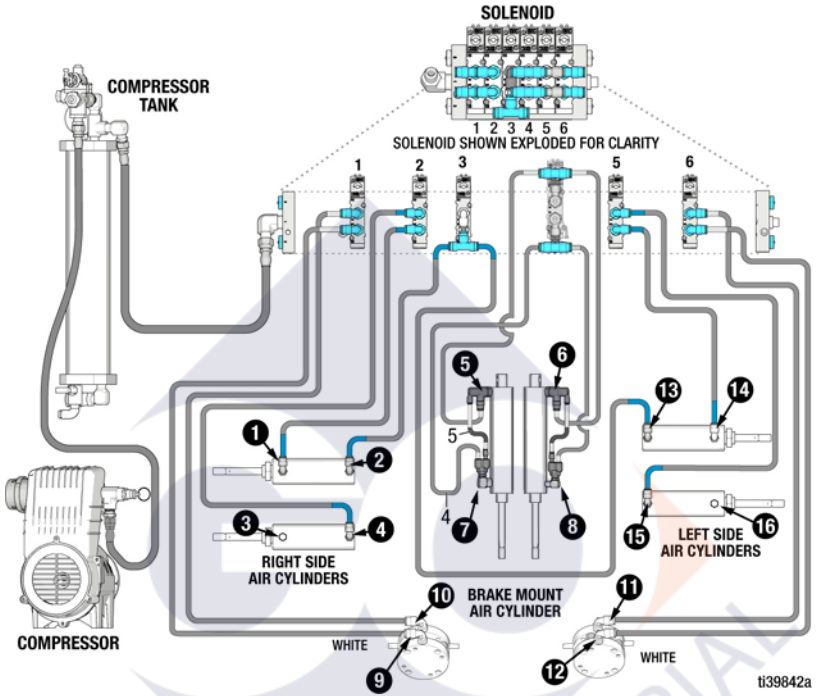

Parts

TapeLazer Parts

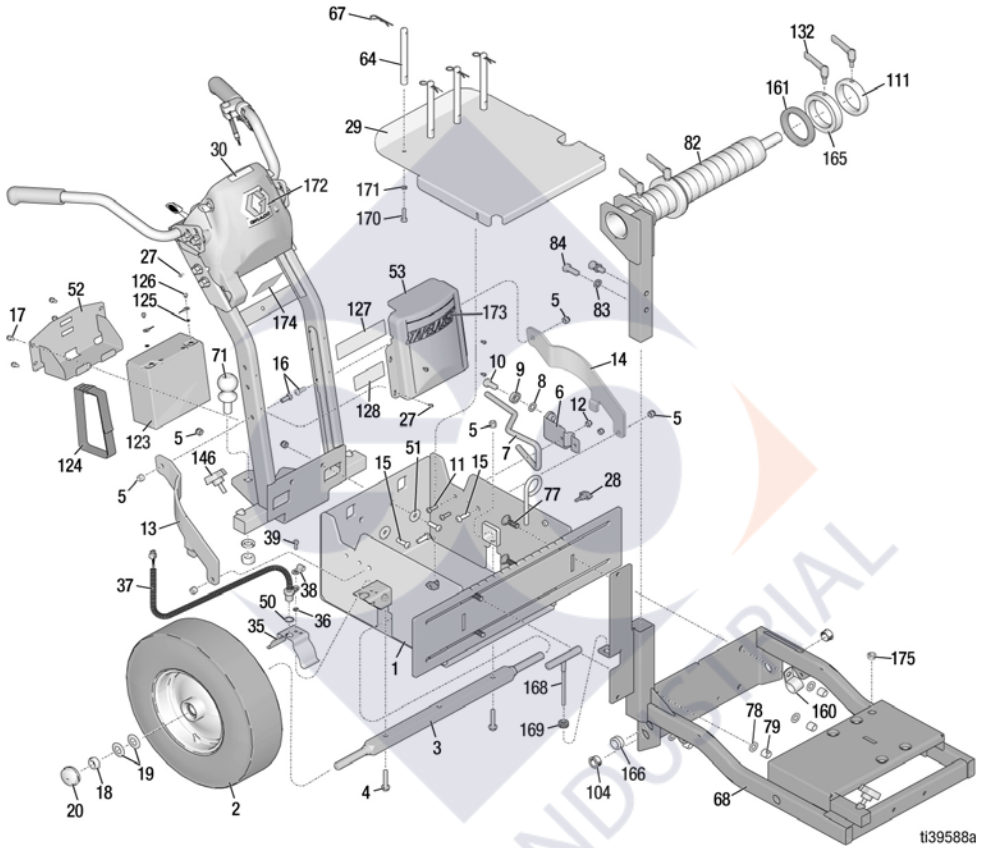

ti39588a

TapeLazer Parts List

Ref.	Part	Description	Qty.	Ref.	Part	Description	Qty.
1	18C621	FRAME, TapeLazer	1	67	123906	PIN, cotter, hairpin	4
2	111020	WHEEL, pneumatic without sensor ring	2	68	18C632	FRAME, front, painted	1
	255162	WHEEL, pneumatic, with sensor ring	2	71	116913	BALL, trailer, <i>includes nut and lock washer</i>	1
3	193405	AXLE	1	77	18C667	BOLT, carriage	4
4	114982	SCREW, cap, flange hd.	2	78	109052	WASHER, plain	4
5	101566	NUT, lock	10	79	101580	NUT, lock	4
6	198891	BRACKET	1	82	18C645	FRAME, weldment, upper tape roll	1
7	198930	ROD, brake	1	83	100018	WASHER, lock, spring	2
8	195134	SPACER, ball, guide	1	84	109012	BOLT, hex hd.	2
9	198931	BEARING	1	104	18C736	BUSHING, strain relief	2
10	113961	SCREW, cap, hex hd.	1	111	18C666	COLLAR, tape guide	2
11	125112	SCREW, cap, 5/16 x 1	2	123	16U160	BATTERY	1
12	111040	SCREW, cap, hex hd.	2	124	126949	STRAP, battery	1
13	15F576	BRACE, right	1	125	111307	WASHER, lock, external	2
14	15F577	BRACE, left	1	126	128131	SCREW, cap, hex hd., M5 x 6mm	2
15	129601	SCREW, cap, button hd., 3/8 x 1.25	4	127 ▲	17K396	LABEL, safety	1
16	128977	SCREW, cap, button hd., 3/8 x 1	2	128 ▲	17K397	LABEL, notice	1
		SCREW	4	132	20A290	LEVER, clamping, adjustable	4
17	107257	NUT, lock	4	146	111145	KNOB, pronged	1
18	112405	WASHER, Belleville	8	160	20A626	CLAMP, wire	1
19	112825	CAP, dust	2	161	15A552	SEAL, replacement	2
20	114648	SCREW, mach., slot hex wash hd.	12	165	20A647	COLLAR, tape guide	2
27	128978	KNOB, T-handle, 1/4-20	4	166	20A595	GROMMET	1
28	16W408	PLATE, cover, frame, rear	1	168	20A443	TOOL, Allen	1
29	18C712	LABEL, A+ service	1	169	20A435	GROMMET	1
30	17P925	SHEILD, distance sensor	1	170	18C661	BOLT	4
35	15J088	SPACER, round	1	171	100214	WASHER	4
36	15K452	SENSOR, distance	1	172	17K379	LABEL, Graco	1
37	18C574	CLAMP, wire	1	173	18C730	LABEL, TapeLazer	1
38	108868	SCREW, hex washer hd.	1	174	17H742	LABEL, brand	1
39	260212	PACKING, O-ring	1	175	119569	BUSHING, strain relief	1
50	155500	WASHER, plain	10				
51	108851	SHELF, battery	1				
52	20A473	COVER, pointed	1				
53	17K377	SHAFT, roller, holder	4				
64	18C716						

▲ Replacement safety labels, tags, and cards are available at no cost.

Parts

Front End Parts

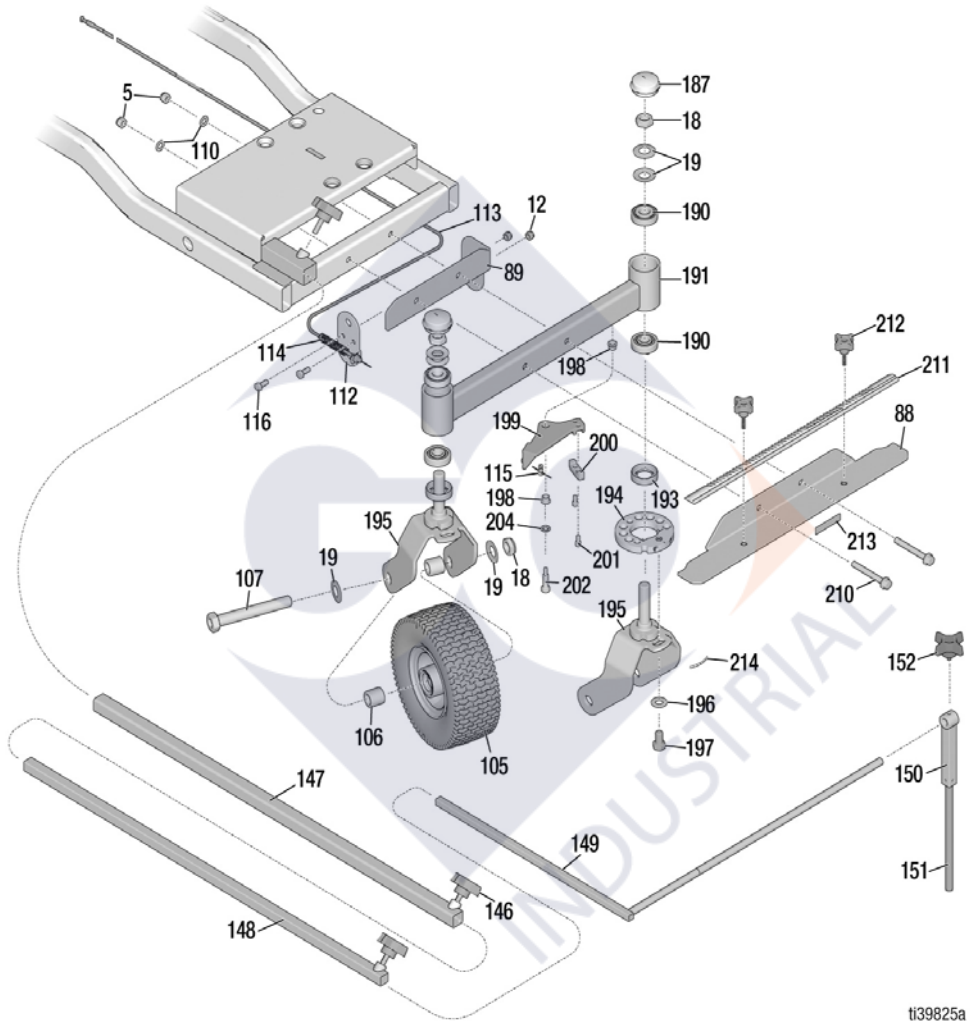

ti39825a

Front End Parts List

Ref.	Part	Description	Qty.	Ref.	Part	Description	Qty.
5	101566	NUT, lock	10	152	114966	KNOB, pronged	1
12	111040	NUT, lock	5	187	114648	CAP, dust	2
18	112405	NUT, lock	4	190	113485	BEARING, cup/cone	4
19	112825	WASHER, Belleville	8	191	18C620	FRAME, caster	1
88	18C619	GUARD, frame, painted	1	193	113484	SEAL, grease	2
89	18C617	BRACKET, wheel lock, painted	1	194	17H486	DISK, adjuster, assembly	1
105	114549	WHEEL, pneumatic	2	195	17H485	FORK, weldment	2
106	193658	SPACER, seal	4	196	113962	WASHER, hardened, SAE	1
107	113471	SCREW, cap, hex hd.	2	197	114681	SCREW, cap, hex hd.	1
110	112914	WASHER, plain	2	198	114548	BEARING, bronze	2
112	15F910	BRACKET, cable	1	199	193528	ARM, detent	1
113	20A220	CABLE, wheel lock	1	200	18C724	STOP, wedge	1
114	114682	SPRING, compression	1	201	110754	SCREW, cap	2
115	114802	STOP, wire	1	202	120476	BOLT, shoulder, 5/16	1
116	100057	SCREW, cap, hex hd.	2	204	15J603	SPACER, round, 0.625 O.D.	1
146	111145	KNOB, pronged	3	210	125626	SCREW, hex, flanged	2
147	24N171	ARM, pointer	1	211	20A484	BLADE (1 pack)	1
	24N162	KIT, accessory, pointer, includes 146, 147, 148, 149, 150, 151, 152	1		20A652	BLADE (3 pack)	1
148	17H438	TUBE, weldment, pointer	1	212	15D862	NUT	2
149	17H441	EXTENSION, pointer, weldment	1	213	17H683	LABEL, brand	1
150	17H445	TUBE, pointer hose, weldment	1	214	17H489	LABEL, disk adjustment	1
151	17H719	HOSE, pointer (1 pack)	1				
	24Y511	HOSE, pointer (5 pack)	1				

▲ Replacement safety labels, tags, and cards are available at no cost.

INDUSTRIAL

Parts

Carriage Applicator Parts

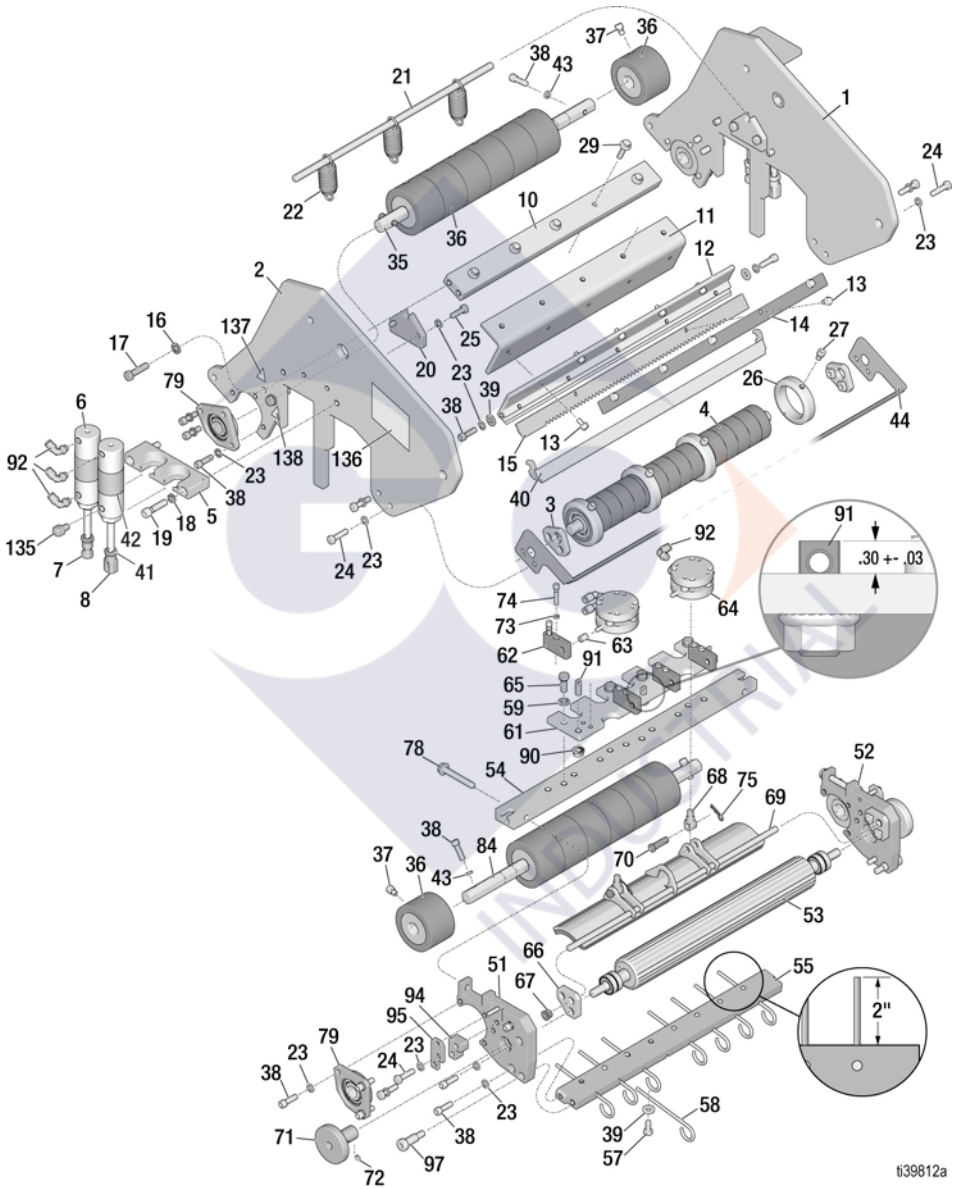

ti39812a

Carriage Applicator Parts List

Ref.	Part	Description	Qty.	Ref.	Part	Description	Qty.
1	20A201	BRACKET, roller mount, left	1	53	18C571	ROLLER, tape applicator	1
2	20A203	BRACKET, roller mount, right	1	54	18C583	BRACKET, cylinder rod support	1
3	18C582	BRACKET, roller mount, 3-hole	2	55	18C584	BRACKET, tape guides lead wire	1
4	18C579	ROLLER, tape guide	1	57	100057	SCREW, cap, hex hd.	8
5	20A338	BRACKET, cylinder mount	2	58	20A653	BRACKET, lead in	8
6	18C598	CYLINDER, air	4	59	100133	WASHER, lock, 3/8	4
7	18C599	BRACKET, cylinder rod mount end	2	61	20A198	PLATE, air cylinder mount	1
8	18C606	BRACKET, cylinder rod mount	2	62	20A211	BLOCK, air cylinder mount	4
10	18C577	BRACKET, cross-member	1	63	18C592	BEARING, sleeve	4
11	18C967	BRACKET, blade mount	1	64	20A210	CYLINDER, air	2
12	20A216	BRACKET, blade mount	1	65	123942	FASTENER, screw	4
13	113161	SCREW, flange, hex hd.	10	66 ◆	18C608	BRACKET, brake, rod mount	2
14	18C602	BRACKET, blade holder top	1	67 ◆	18C636	BEARING, bronze	2
15	20A484	KIT, blade (1 pack), includes 23, 38, 39, 40,	1	68	18C635	ADAPTER, rod	2
	20A652	KIT, blade (3 pack), includes 23, 38, 39, 40	1	69	20A488	KIT, brake, includes 23, 38, 66, 67, 70, 75	1
16	100133	WASHER, lock, 3/8	4	70 ◆	18C637	PIN	2
17	102637	SCREW, cap	4	71	18C594	HANDLE, roller advance	2
18	106115	WASHER, lock, 3/8	4	72	126943	FASTENER, set screw, 1/4 - 20	2
19	102886	SCREW, cap	4	73	105510	WASHER, lock	8
20	18C613	BRACKET, spring mount	2	74	103345	SCREW, cap sch.	8
21	18C614	ROD, spring mount	1	75 ◆	120592	PIN, cotter, hairpin	2
22	18C612	SPRING, extension	3	78	123443	SCREW, cap, flange hd.	2
23 ◆	100214	WASHER, lock	16	79	20A521	KIT, housing, bearing, includes 23, 38	4
24	18C661	SCREW, cap, hex hd.	4	84 †	18C958	SHAFT, application roller	1
25	124227	SCREW, cap, hex hd., 5/16 - 18 x 1.00	4	90	112958	NUT, hex 3/8 - 16	3
26	18C615	COLLAR, tape guide	4	91	18C593	BRACKET, spring mount	3
27	128167	SCREW, cap, 5/16 - 18	4	92	112698	FITTING, male swivel	10
29	126596	SCREW, flange, hex, 5/16 - 18 x 1.25	5	94	18C586	BRACKET, cylinder rod support	2
35 *	18C952	SHAFT, tamper roller, hex	1	95	18C971	PLATE, support	2
36 †	20A487	KIT, cylinder, roller, includes 37	14	97	126833	SCREW, shoulder	2
37 †	126953	SCREW, sch, 5/16 - 18 x 3/8	14	135	100839	FITTING, elbow	2
38 †◆	128190	SCREW, cap, socket hd., 5/16 - 18	10	136 ▲	20A264	LABEL, tape feed	1
39	100527	WASHER, plain	10	137 ▲	15H108	LABEL, safety	2
40	20A327	GUARD, blade	1	138 ▲	20A263	LABEL, safety, blade	2
41	150513	NUT, hex, jam, 7/16 x 20	4		20A485	KIT, roller, tamper, includes 35, 36, 37, 38, 43	1
42	18C731	LABEL, brand, side	4		20A486	KIT, roller, application, includes 84, 36, 37, 38, 43	1
43 †	104008	WASHER, lock, spring	2		20A488	KIT, tape break, includes 23, 38, 66, 67, 70, 75	1
44	20A648	BRACKET, tape break	1				
51	20A654	KIT, bracket, right, swing arm	1				
52	20A655	KIT, bracket, left, swing arm	1				

▲ Replacement safety labels, tags, and cards are available at no cost.

* Included in KIT 20A485

† Included in KIT 20A486

◆ Included in KIT 20A488

Parts

Display Unit Parts

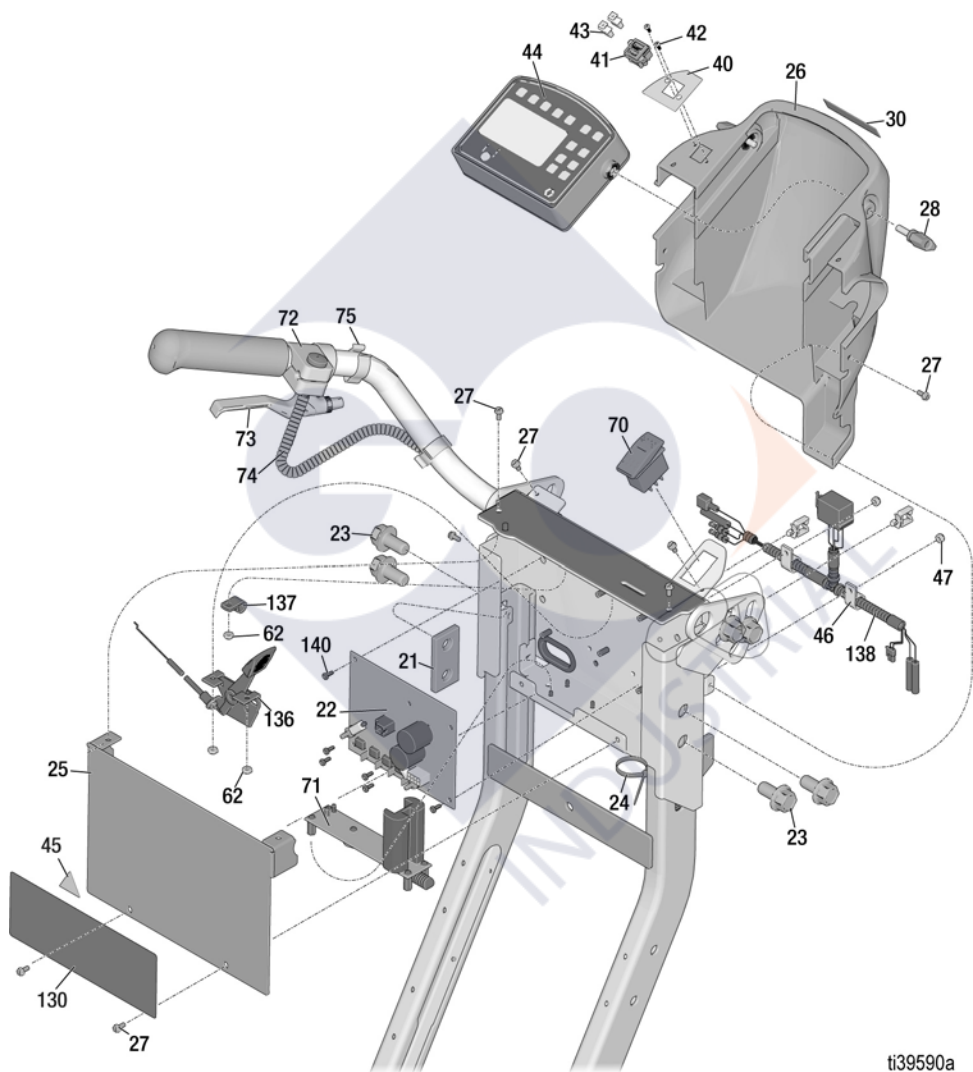

ti39590a

Display Unit Parts List

Ref.	Part	Description	Qty.	Ref.	Part	Description	Qty.
21	17J125	BRACKET, slide	2	47	115483	NUT, lock	2
22	20A658	KIT, control, auto, TapeLazer	1	62	111280	NUT, locking	5
23	17J136	SCREW, hex, flange hd.	4	70	128783	SWITCH, rocker	1
24	17H720	STRAP, tie	4	71	25A495	KIT, board, charger, battery, <i>includes 62,</i>	1
25	17J123	PLATE, cover	1	72	15K162	BLOCK, switch	1
26	17V517	COVER, control, USB, painted	1	73	194310	LEVER, actuator	1
27	128978	SCREW, mach, slot hex wash hd.	12	74	17J236	SWITCH, pushbutton	1
28	16W408	KNOB, T-handle	4	75	178342	CLIP, spring	2
30	17P925	LABEL, A+	1	130 ▲	198918	LABEL, warning	1
40	17V520	LABEL, USB	1	136	20A657	KIT, control, throttle, <i>includes 62, 137</i>	1
41	17Z084	KIT, board, USB, <i>includes 40, 42, 43</i>	1	137	119736	CLAMP, cable	1
42	17V519	SCREW, pan hd.	2	138	18C575	HARNESS, wiring, TapeLazer	1
43	131718	COVER, dust, USB	2	140	120593	SCREW, torx	10
44	20A659	KIT, box, display, <i>includes 28</i>	1	▲ Replacement safety labels, tags, and cards are available at no cost.			
45 ▲	189930	LABEL, caution	1				
46	128856	CLAMP, cable, nylon	2				

Parts

Additional Parts

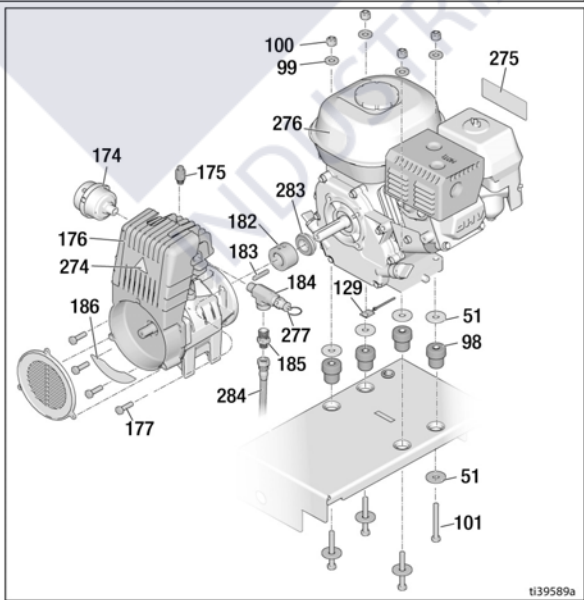
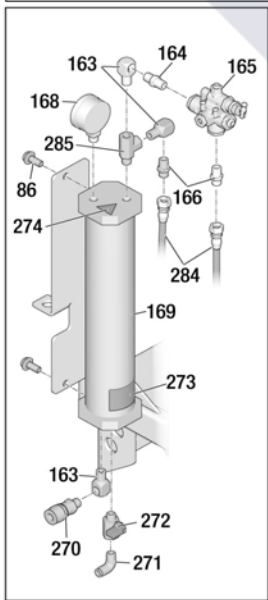
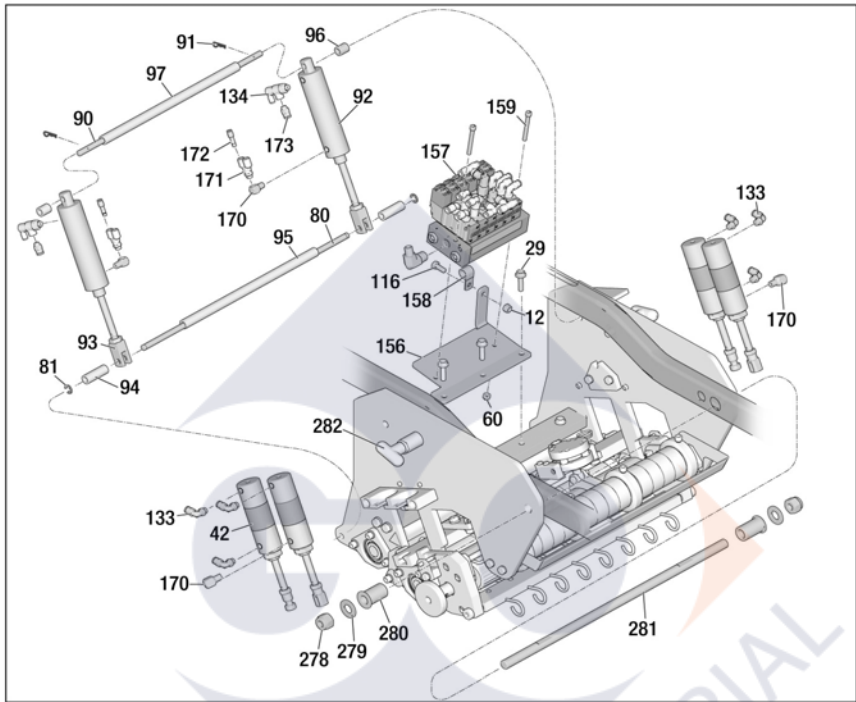

t139589a

Additional Parts List

Ref.	Part	Description	Qty.	Ref.	Part	Description	Qty.
12	111040	NUT, lock	5	172	125423	FITTING, reducer, plug	2
29	126596	SCREW, flange	5	173	115671	FITTING, connector	2
42	18C731	LABEL, brand, side	4	174 †	25R115	FILTER, air	1
51	108851	WASHER, plain	10	175 †	25R114	BREATHER, oil	1
60	102040	NUT, lock, hex	4	176	19C950	KIT, compressor, <i>includes 174, 175, 182a, 183, 283, 177, 186</i>	1
80	18C638	ROD, cylinder mount lower	1	177	100184	SCREW	4
81	101134	RING, retaining	2	182a †	19B286	KIT, collar, shaft, <i>includes 182b, 183c, and 184d</i>	1
86	111192	SCREW, cap flange hd.	2	182b	25R109	COLLAR, shaft	1
90	18C647	SHAFT, air cylinder mount upper	1	182c	25R110	SET SCREW, M5x8	1
91	120592	PIN, cotter, hairpin	2	182d	25R111	SET SCREW, M8x10	4
92	18C648	CYLINDER, air	2	183	25R126	KEY, square, 3/16 x 1.34	1
93	18C649	CLEVIS, cylinder, air and nut	2	184	124490	FITTING, tee	1
94	18C650	TUBE, cylinder, lift	2	185	164672	ADAPTER	1
95	18C651	TUBE, cylinder, lift	1	186	25R330	GASKET, adhesive	1
96	18C652	TUBE, cylinder, lift	2	270	116720	COUPLER, quick disconnect	1
97	18C653	TUBE, cylinder, lift	1	271	113321	FITTING, elbow, tube	1
98	15E888	DAMPENER, motor mount	4	272	15B565	VALVE, ball	1
99	100023	WASHER, flat	4	273 ▲	20A265	LABEL, relief, pressure, air	1
100	110838	NUT, lock	4	274 ▲	15K616	LABEL, caution	2
101	113664	SCREW, cap, hex hd.	4	275 ▲	194126	LABEL, safety, warning	1
116	100057	SCREW, cap, hex hd.	3	276	114530	ENGINE, Honda	1
129	240997	CONDUCTOR, ground	1	277	20A303	VALVE, safety	1
133	112698	ELBOW, male, swivel	6	278	101712	NUT, lock	2
134	20A642	VALVE, unidirectional	1	279	111841	WASHER, plain	2
156	20A587	BRACKET, valve mount	1	280	18C646	BUSHING, flanged	2
157	20A588	VALVE, air solenoid (6 pack)	1	281	18C633	SHAFT, roller frame mount	1
158	17H721	CLAMP, wire	1	282	18C654	PLUNGER, spring	2
159	C19817	SCREW, cap, socket hd.	2	283 †	19C949	SPACER, motor	1
163	187357	ELBOW, street	3	284	16T939	HOSE, coupled	2
164	156971	FITTING, nipple	1	285	116504	FITTING, tee, run	1
165	20A206	REGULATOR, unloader	1				
166	162453	FITTING,	2				
168	101180	GAUGE, pressure	1				
169	16U174	TANK, pressure	1				
170	100839	FITTING, elbow, street	4				
171	20A644	FITTING, tube	2				

▲ Replacement safety labels, tags, and cards are available at no cost.

† Parts included with 19C950 (Compressor).

Air Line Schematic

Air Line Schematic

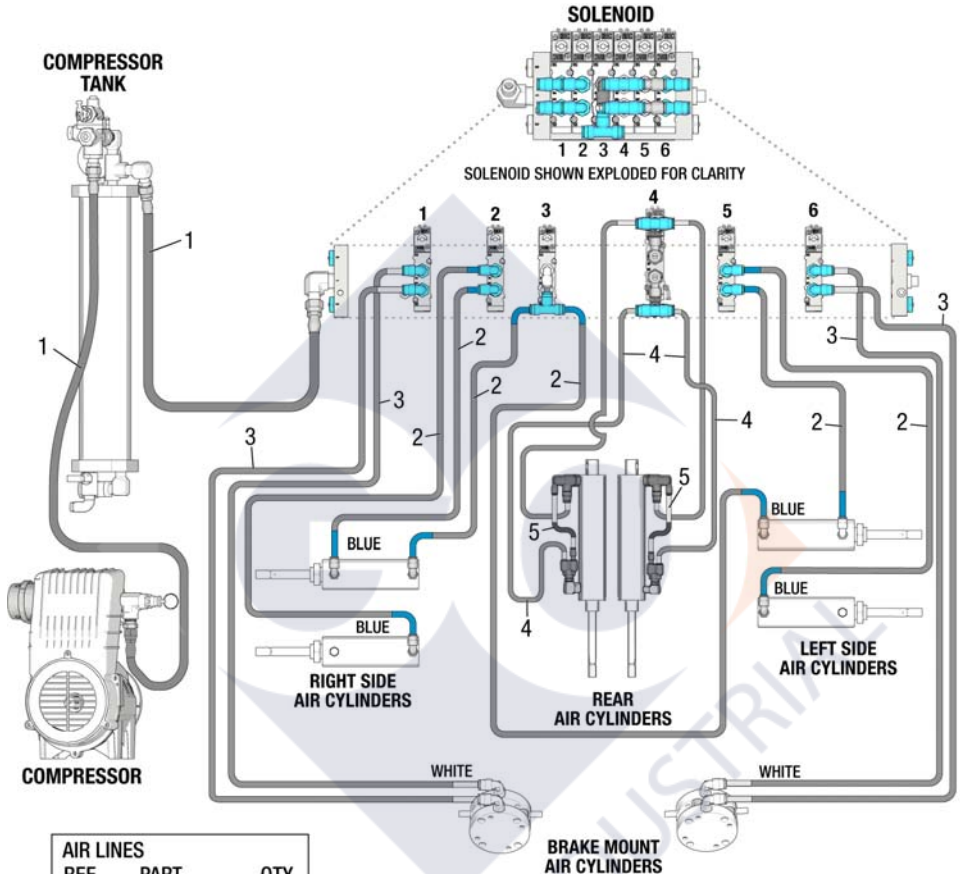

AIR LINES		
REF.	PART	QTY
1	16T939	2
2	20A438	6
3	20A437	4
4	20A439	4
5	20A628	2

ti39583a

Air Line Connection Sequence

Air Line Connection Sequence

When connecting air lines to solenoids they can often be difficult to lay into the unit. It is helpful to connect them in the order shown in the pictures below to avoid difficult connections later on. Connection order doesn't matter for performance, only for the ease of the user.

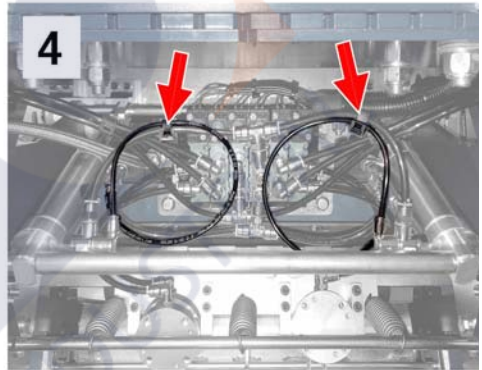
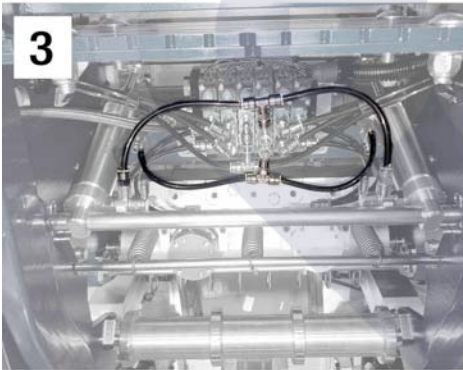
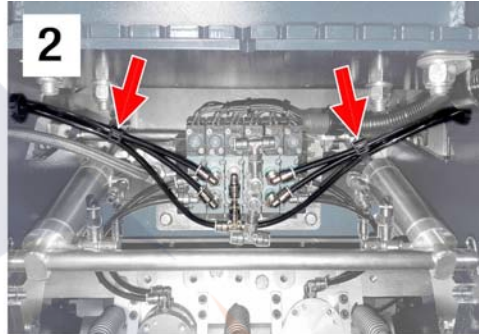
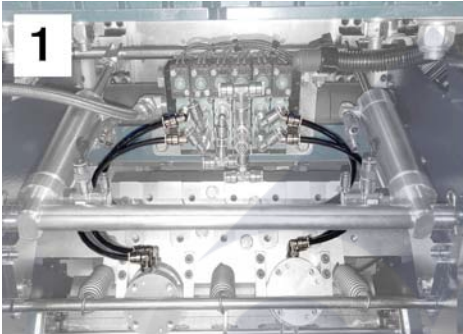

Wiring Diagram

Wiring Diagram

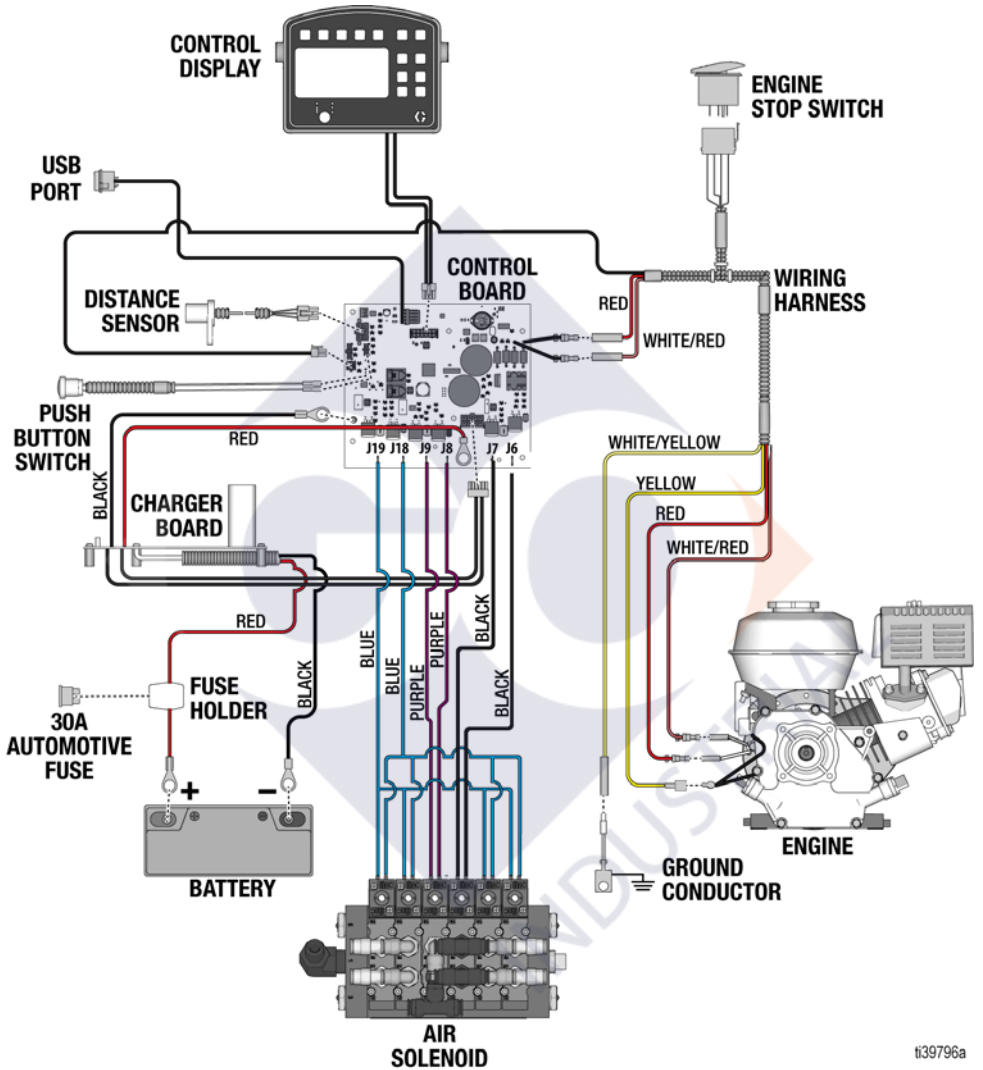

ti39796a

Universal Symbols Key

SYMBOL KEY MENU SCREENS

STRIPING MODE	SETTINGS/DATA	MEASURE MODE	DATA LOGGING
<p>[M] MANUAL MODE</p> <p>[S] SEMI-AUTOMATIC MODE</p> <p>[A] AUTOMATIC MODE</p>	<p> SETTINGS</p> <p> INFORMATION & LIFE DATA</p>	<p>PRESS TO START/STOP</p> <p>I/O </p>	<p> DATA LOGGING</p> <p> START RECORDING NEW JOB</p>
<p> TAPE BEING APPLIED</p> <p> TAPE NOT BEING APPLIED</p> <p>OFF ON</p> <p> SYSTEM DELAY</p> <p> SYSTEM DELAY</p> <p> SKIP</p> <p> SOLID</p> <p> SKIP LENGTH</p> <p> SPACE LENGTH</p> <p> LINE WIDTH</p>	<p> ENGINE HOURS</p> <p>Σ TOTAL DISTANCE</p> <p> ERROR CODES</p> <p> CONTRAST</p> <p> DIAGNOSTICS</p> <p> TIME AND DATE</p> <p> CALIBRATION</p> <p> TAPE CUT DELAY</p>	<p>DISKETTE BUTTON POPUP</p> <p> </p> <p>VIEW JOBS</p> <p> </p>	
<p> EXIT</p> <p> WHITE</p> <p> WHITE w CONTRAST</p> <p> YELLOW</p> <p> YELLOW w CONTRAST</p> <p> BLACK</p> <p> OTHER</p>	<p> START SKIP</p> <p> START SPACE</p>	<p>VIEW JOBS</p> <p>JOB 1</p> <p> 26.02.2021 11:02</p> <p>INDIVIDUAL JOB SUMMARY</p> <p>JOB TOTAL Σ 35.1 FT</p> <p>SKIP TOTAL Σ 12.0 FT</p> <p>SOLID TOTAL Σ 23.1 FT</p> <p>35.1 FT</p> <p>SAME COLOR AS TAPE WIDTH & TYPE STRIPING SCREEN</p>	
<p> BATTERY CHARGING</p> <p> BATTERY NOT CHARGING</p>	<p> SHORT CIRCUIT DETECTED</p> <p> OPEN CIRCUIT DETECTED</p> <p> OUTPUT 1</p> <p> OUTPUT 2</p> <p> CLUTCH OUTPUT</p>	<p> SCROLL</p> <p> DELETE</p> <p> TIME AND DATE</p>	
<p> JOB NUMBER</p> <p> < 1' FROM START OF SKIP - BUTTON PRESS IGNORED</p> <p> < 1' FROM END OF SKIP - BUTTON PRESS IGNORED</p> <p> PROBLEM WITH BATTERY</p>	<p> BUTTON PRESS COUNT</p> <p> DISTANCE SENSOR COUNT</p> <p> 34.21V ALTERNATOR VOLTAGE</p> <p> 13.56V BATTERY VOLTAGE</p>		
	<p> OUTPUT ON</p> <p>OK, SHORT OR OPEN DISPLAYS ONLY WHEN ON</p> <p> FLASHES TO SHOW CARRIAGE CAN MOVE</p>		

i39735a

Technical Specifications

Technical Specifications

TapeLazer		
	U.S.	Metric
Dimensions		
Height (with handlebar down)	Unpackaged - 41 in. Packaged - 53 in.	Unpackaged - 104 cm Packaged - 135 cm
Width	Unpackaged - 28 in. Packaged - 33 in.	Unpackaged - 71 cm Packaged - 84 cm
Length (with handlebar down)	Unpackaged - 74 in. Packaged - 81 in.	Unpackaged - 188 cm Packaged - 206 cm
Weight (without tape)	Unpackaged - 512 lbs Packaged - 613 lbs	Unpackaged - 232 kg Packaged - 278 kg
Noise (dBa)		
Sound Power per ISO 3744:	104 dBa	
Sound Pressure per ISO 3744 (measured at 3.1 feet/1.0 m):	84 dBa	
Vibration (m/s²) (8 hours daily exposure)		
Hand Arm (per ISO 5349)		
TapeLazer Only	Left hand: 6.2 Right hand: 5.4	
TapeLazer Coupled to Gas LineDriver	Left hand: 6.5 Right hand: 5.6	
Power Rating (Horsepower)		
Power Rating (Horsepower) per SAE J1349	5.5 HP @ 3600 rpm	4.1 kW @ 3600 rpm
Maximum Tape Width		
	14 inches	35 cm
Maximum Speed*		
	6 MPH	
Maximum Working Pressure		
	145 psi	1.0 MPa, 10 bar
Electrical Capacity		
	84 W @ 3600 rpm	
Battery		
	12V, 22Ah, Sealed lead acid, Deep cycle	
Compressor Flow @ 120 psi		
	6.0 ScFM	

* **Note:** Follow application instructions provided by tape manufacturer.

California Proposition 65

CALIFORNIA RESIDENTS

 **WARNING:** Cancer and reproductive harm – www.P65warnings.ca.gov.

Graco Standard Warranty

Graco warrants all equipment referenced in this document which is manufactured by Graco and bearing its name to be free from defects in material and workmanship on the date of sale to the original purchaser for use. With the exception of any special, extended, or limited warranty published by Graco, Graco will, for a period of twelve months from the date of sale, repair or replace any part of the equipment determined by Graco to be defective. This warranty applies only when the equipment is installed, operated and maintained in accordance with Graco's written recommendations.

This warranty does not cover, and Graco shall not be liable for general wear and tear, or any malfunction, damage or wear caused by faulty installation, misapplication, abrasion, corrosion, inadequate or improper maintenance, negligence, accident, tampering, or substitution of non-Graco component parts. Nor shall Graco be liable for malfunction, damage or wear caused by the incompatibility of Graco equipment with structures, accessories, equipment or materials not supplied by Graco, or the improper design, manufacture, installation, operation or maintenance of structures, accessories, equipment or materials not supplied by Graco.

This warranty is conditioned upon the prepaid return of the equipment claimed to be defective to an authorized Graco distributor for verification of the claimed defect. If the claimed defect is verified, Graco will repair or replace free of charge any defective parts. The equipment will be returned to the original purchaser transportation prepaid. If inspection of the equipment does not disclose any defect in material or workmanship, repairs will be made at a reasonable charge, which charges may include the costs of parts, labor, and transportation.

THIS WARRANTY IS EXCLUSIVE, AND IS IN LIEU OF ANY OTHER WARRANTIES, EXPRESS OR IMPLIED, INCLUDING BUT NOT LIMITED TO WARRANTY OF MERCHANTABILITY OR WARRANTY OF FITNESS FOR A PARTICULAR PURPOSE.

Graco's sole obligation and buyer's sole remedy for any breach of warranty shall be as set forth above. The buyer agrees that no other remedy (including, but not limited to, incidental or consequential damages for lost profits, lost sales, injury to person or property, or any other incidental or consequential loss) shall be available. Any action for breach of warranty must be brought within two (2) years of the date of sale.

GRACO MAKES NO WARRANTY, AND DISCLAIMS ALL IMPLIED WARRANTIES OF MERCHANTABILITY AND FITNESS FOR A PARTICULAR PURPOSE, IN CONNECTION WITH ACCESSORIES, EQUIPMENT, MATERIALS OR COMPONENTS SOLD BUT NOT MANUFACTURED BY GRACO. These items sold, but not manufactured by Graco (such as electric motors, switches, hose, etc.), are subject to the warranty, if any, of their manufacturer. Graco will provide purchaser with reasonable assistance in making any claim for breach of these warranties.

In no event will Graco be liable for indirect, incidental, special or consequential damages resulting from Graco supplying equipment hereunder, or the furnishing, performance, or use of any products or other goods sold hereto, whether due to a breach of contract, breach of warranty, the negligence of Graco, or otherwise.

FOR GRACO CANADA CUSTOMERS

The Parties acknowledge that they have required that the present document, as well as all documents, notices and legal proceedings entered into, given or instituted pursuant hereto or relating directly or indirectly hereto, be drawn up in English. Les parties reconnaissent avoir convenu que la rédaction du présente document sera en Anglais, ainsi que tous documents, avis et procédures judiciaires exécutés, donnés ou intentés, à la suite de ou en rapport, directement ou indirectement, avec les procédures concernées.

Graco Information

For the latest information about Graco products, visit www.graco.com.

For patent information, see www.graco.com/patents.

TO PLACE AN ORDER, contact your Graco distributor or call 1-800-690-2894 to identify the nearest distributor.



All written and visual data contained in this document reflects the latest product information available at the time of publication. Graco reserves the right to make changes at any time without notice.

Original instructions. This manual contains English. MM 3A8108

Graco Headquarters: Minneapolis

International Offices: Belgium, China, Japan, Korea

GRACO INC. AND SUBSIDIARIES • P.O. BOX 1441 • MINNEAPOLIS MN 55440-1441 • USA

Copyright 2021, Graco Inc. All Graco manufacturing locations are registered to ISO 9001.

www.graco.com

Revision B, September 2021