

DutyMax EH/GH™ 230/300, DH230 HD Hydraulic Sprayers

334606J

EN

For professional use only.

Not approved for use in explosive atmosphere or hazardous locations.

For portable airless spraying of architectural paints and coatings.

3300 psi (22.8 MPa, 228 bar) Maximum Working Pressure

See page 3 for model information, including maximum working pressure and approvals.



Important Safety Instructions

Read all warnings and instructions in this manual and in related manuals.

Be familiar with the controls and the proper usage of the equipment.

Save these instructions.

Related Manuals:

308491	DutyMax DH/GH230 Gun	334654	Pump
309495	DutyMax GH300 Gun	310812	Electric Motor

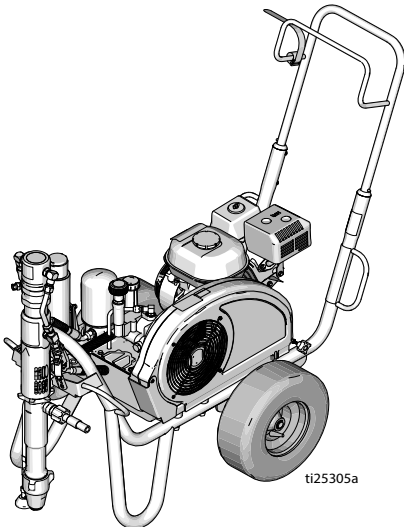

Standard Series

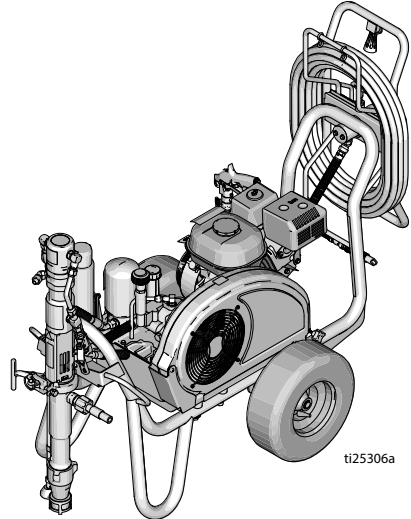

ProContractor Series

Use only genuine Graco replacement parts.

The use of non-Graco replacement parts may void warranty.



Table of Contents

Models	3
Electric Motor Kit Options	3
OEM Kits	3
Warnings	4
Electric Motor Warnings	4
Internal Combustion Engine Warnings	7
Electric Motor/Internal Combustion Engine Warnings	8
Component Identification	11
Standard Models (EH/GH230, 300 HD)	11
ProContractor Models (EH/GH230, 300 HD)	12
ProContractor Model (DH230 HD)	13
Grounding	14
Grounding Procedure for Gas Engine	14
Grounding Procedure for Electric Motor	14
Grounding of Pails	15
Circuit Protection	15
Setup	16
Change Engine or Motor	16
Complete Setup	17
Pressure Relief Procedure	19
Startup (Internal Combustion Models)	20
Startup (Electric Models)	23
How to Spray	25
Switch Tip™ and Guard Assembly	25
Spray	25
Clear Tip Clogs	26
Hose Reel	26
Clean Up	27
Maintenance	29
Troubleshooting	31
Standard Series Pump	33
ProContractor Series Pump	34
DutyMax EH/GH230/300 HD Standard Series Parts	37
DutyMax DH230/EH/GH230/300 HD ProContractor Series	49
Technical Data	64
DutyMax EH230 HD Standard Series	64
DutyMax EH300 HD Standard Series	65
DutyMax GH230 HD Standard Series	66
DutyMax GH300 HD Standard Series	67
DutyMax EH230 HD ProContractor Series	68
DutyMax EH300 HD ProContractor Series	69
DutyMax DH230/GH230 HD ProContractor Series	70
DutyMax GH300 HD ProContractor Series	71
Graco Standard Warranty	75
Graco Information	76

Setup

Setup

Change Engine or Motor

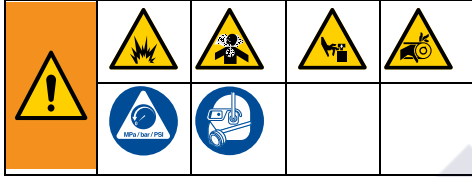

- 1 Turn motor OFF and unplug or turn engine to the OFF/STOP position. Loosen belt guard knob and motor clamp. Perform **Pressure Relief Procedure**, page 15.

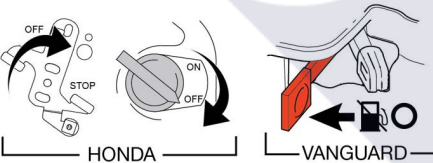
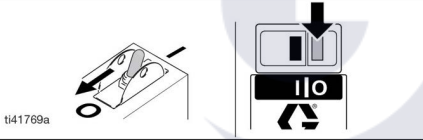
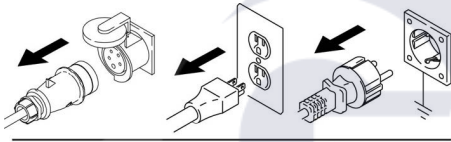

- 2 Lift belt guard. Remove belt. Tilt engine/motor and remove engine/motor.

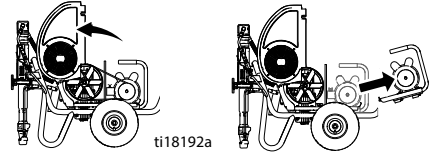

- 3 Tilt engine/motor. Install engine/motor. Install belt. Lower belt guard.

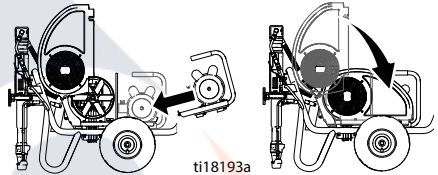

- 4 Swivel motor clamp. Tighten motor clamp and belt guard knob.

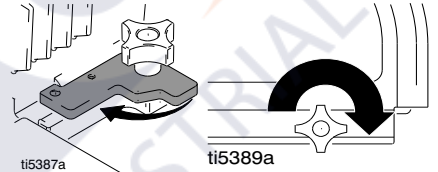

Complete Setup

1. **All sprayers except ProContractor:**
Connect appropriate Graco high-pressure hose to sprayer.

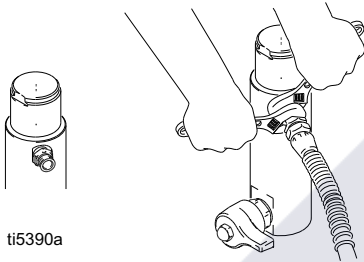

2. Install hose to spray gun and tighten securely.

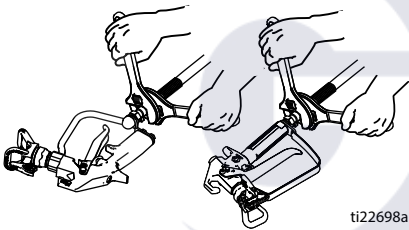

3. Engage gun trigger lock.



4. Remove Tip Guard.

5. **Standard Series:** Screw inlet strainer to bottom of suction hose and hand tighten securely.

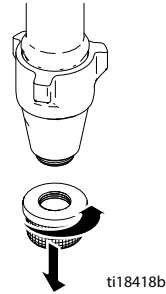

6. When spraying texture, remove inlet strainer and filter bowl screen.

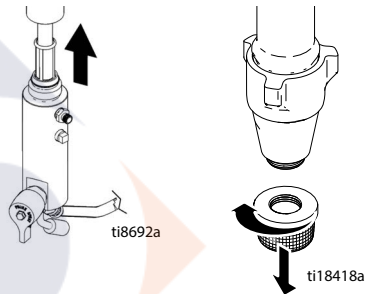

7. Fill throat packing nut with TSL to prevent premature packing wear. Do this each time you spray.

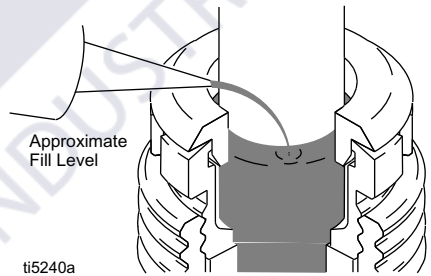

8. Check engine oil level.
GASOLINE ENGINE

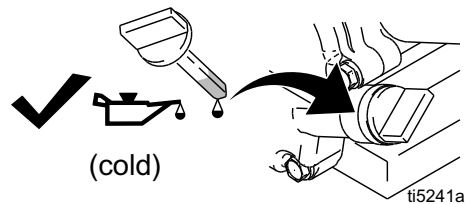

Setup

DIESEL ENGINE

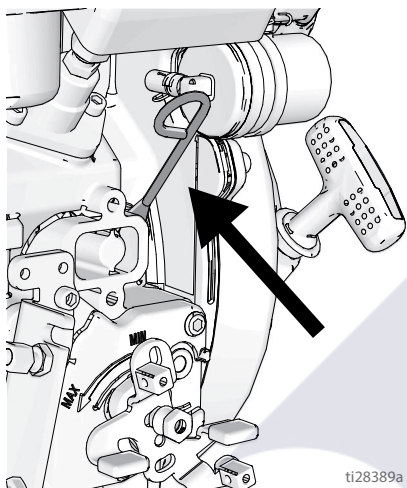

10. Check hydraulic oil level. See page 29 for hydraulic oil specifications. Add hydraulic oil as needed until the level is between the MIN and MAX (Safe Range when cold). Hydraulic tank capacity is five quarts (4.75 liters).



9. Fill fuel tank.

GASOLINE ENGINE

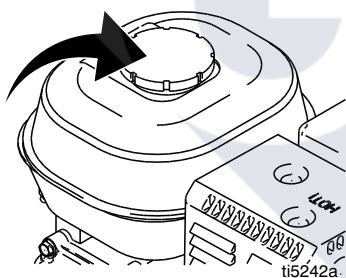

11. Attach sprayer grounding clamp to earth ground.

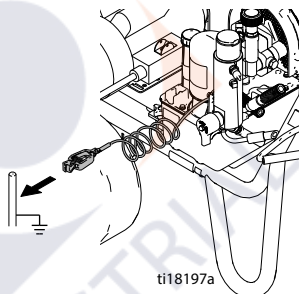

DIESEL ENGINE

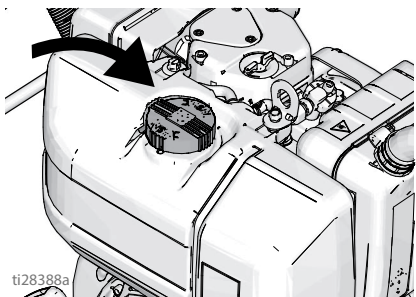

Pressure Relief Procedure



Follow the **Pressure Relief Procedure** whenever you see this symbol.

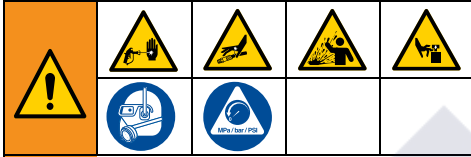

This equipment stays pressurized until pressure is manually relieved. To help prevent serious injury from pressurized fluid, such as skin injection, splashing fluid and moving parts, follow the **Pressure Relief Procedure** when you stop spraying and before cleaning, checking, or servicing the equipment.

1. Engage trigger lock.
2. Turn sprayer OFF:
 - Turn gas engine or electric motor ON/OFF switch to OFF. For Vanguard models turn fuel level to OFF position.

OR

 - Move Diesel throttle lever to STOP.

OR

 - Unplug power cord to electric motor.

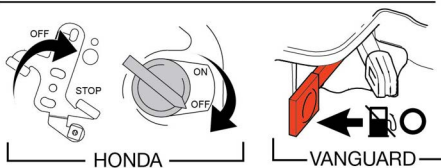
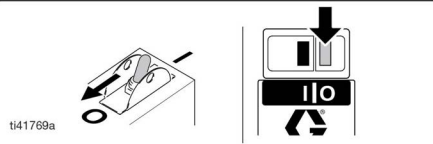
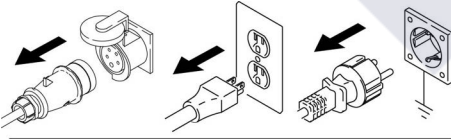

3. Move pump valve to OFF and turn pressure control knob fully counter-clockwise to lowest setting.
4. Disengage trigger lock. Hold metal part of gun firmly to side of grounded metal pail, and trigger gun to relieve pressure.
5. Engage gun trigger lock.
6. Turn prime valve down to DRAIN position. Leave prime valve down until ready to spray again.
7. If you suspect the spray tip or hose is clogged or that pressure has not been fully relieved:
 - a. VERY SLOWLY loosen tip guard retaining nut or hose end coupling to relieve pressure gradually.
 - b. Loosen nut or coupling completely.
 - c. Clear hose or tip obstruction.

Graco Standard Warranty

Graco warrants all equipment referenced in this document which is manufactured by Graco and bearing its name to be free from defects in material and workmanship on the date of sale to the original purchaser for use. With the exception of any special, extended, or limited warranty published by Graco, Graco will, for a period of twelve months from the date of sale, repair or replace any part of the equipment determined by Graco to be defective. This warranty applies only when the equipment is installed, operated and maintained in accordance with Graco's written recommendations.

This warranty does not cover, and Graco shall not be liable for general wear and tear, or any malfunction, damage or wear caused by faulty installation, misapplication, abrasion, corrosion, inadequate or improper maintenance, negligence, accident, tampering, or substitution of non-Graco component parts. Nor shall Graco be liable for malfunction, damage or wear caused by the incompatibility of Graco equipment with structures, accessories, equipment or materials not supplied by Graco, or the improper design, manufacture, installation, operation or maintenance of structures, accessories, equipment or materials not supplied by Graco.

This warranty is conditioned upon the prepaid return of the equipment claimed to be defective to an authorized Graco distributor for verification of the claimed defect. If the claimed defect is verified, Graco will repair or replace free of charge any defective parts. The equipment will be returned to the original purchaser transportation prepaid. If inspection of the equipment does not disclose any defect in material or workmanship, repairs will be made at a reasonable charge, which charges may include the costs of parts, labor, and transportation.

THIS WARRANTY IS EXCLUSIVE, AND IS IN LIEU OF ANY OTHER WARRANTIES, EXPRESS OR IMPLIED, INCLUDING BUT NOT LIMITED TO WARRANTY OF MERCHANTABILITY OR WARRANTY OF FITNESS FOR A PARTICULAR PURPOSE.

Graco's sole obligation and buyer's sole remedy for any breach of warranty shall be as set forth above. The buyer agrees that no other remedy (including, but not limited to, incidental or consequential damages for lost profits, lost sales, injury to person or property, or any other incidental or consequential loss) shall be available. Any action for breach of warranty must be brought within two (2) years of the date of sale.

GRACO MAKES NO WARRANTY, AND DISCLAIMS ALL IMPLIED WARRANTIES OF MERCHANTABILITY AND FITNESS FOR A PARTICULAR PURPOSE, IN CONNECTION WITH ACCESSORIES, EQUIPMENT, MATERIALS OR COMPONENTS SOLD BUT NOT MANUFACTURED BY GRACO. These items sold, but not manufactured by Graco (such as electric motors, switches, hose, etc.), are subject to the warranty, if any, of their manufacturer. Graco will provide purchaser with reasonable assistance in making any claim for breach of these warranties.

In no event will Graco be liable for indirect, incidental, special or consequential damages resulting from Graco supplying equipment hereunder, or the furnishing, performance, or use of any products or other goods sold hereto, whether due to a breach of contract, breach of warranty, the negligence of Graco, or otherwise.

FOR GRACO CANADA CUSTOMERS

The Parties acknowledge that they have required that the present document, as well as all documents, notices and legal proceedings entered into, given or instituted pursuant hereto or relating directly or indirectly hereto, be drawn up in English. Les parties reconnaissent avoir convenu que la rédaction du présente document sera en Anglais, ainsi que tous documents, avis et procédures judiciaires exécutés, donnés ou intentés, à la suite de ou en rapport, directement ou indirectement, avec les procédures concernées.

Graco Information

For the latest information about Graco products, visit www.graco.com.

For patent information, see www.graco.com/patents.

TO PLACE AN ORDER, contact your Graco distributor or call 1-800-690-2894 to identify the nearest distributor.



All written and visual data contained in this document reflects the latest product information available at the time of publication.

Graco reserves the right to make changes at any time without notice.

Original instructions. This manual contains English. MM 334606

Graco Headquarters: Minneapolis

International Offices: Belgium, China, Japan, Korea

GRACO INC. AND SUBSIDIARIES • P.O. BOX 1441 • MINNEAPOLIS MN 55440-1441 • USA

Copyright 2014, Graco Inc. All Graco manufacturing locations are registered to ISO 9001.

www.graco.com

Revision J, August 2022