

Python™ Chemical Injection Pump

3A4386E

(For Applications Requiring ATEX Approval)

EN

**Pneumatic pump for injecting chemicals at well sites. For use with compressed air only.
For professional use only.**

See page 3 for model information, including maximum working pressures.



Important Safety Instructions

Read all warnings and instructions in this manual.
Save all instructions.

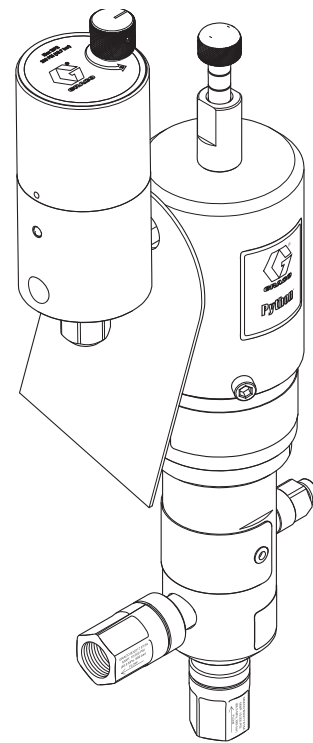

CE  II 2 G Ex h T6 Gb

Contents

Models	3
Configuration Number Matrix	4
Key Points	4
Warnings	5
Component Identification	7
Installation	8
Grounding	8
Required Accessories	8
Flush Before Using Equipment	8
Typical Installation	9
Mount the Pump and Connect Chemical Supply	9
Connect Pneumatic Supply	10
Connect Chemical Outlet	10
Operation	17
Pressure Relief Procedure	17
Flush the Equipment	17
Prime the Pump	18
Calibrate Chemical Dosage	19
Maintenance	22
Preventive Maintenance Schedule	22
Tighten Threaded Connections	22
Tighten Packings	22
Storage	22
Troubleshooting	23
Repair	25
Pump	25
Check Valves	30
Timing Valve	33
Parts	37
Python Pneumatic Pump	37
Python Timing Valve Assembly	41
Kits and Accessories	43
Dimensions	44
Python Pump Dimensions	44
Performance Charts	45
1 1/4" Air Motors (PCI-125)	45
1 3/4" Air Motors (PCI-175)	49
2" Air Motors (PCI-200)	52
Technical Data	57
California Proposition 65	57
Graco Standard Warranty	58

Models

Plunger Size	Air Motor Size	Maximum Working Pressure psi (MPa, bar)	Maximum Pneumatic Inlet Pressure psi (MPa, bar)
1/8 in.	1-1/4 in.	12,000 (82.7, 827)	170 (1.17, 11.7)
3/16 in.		6500 (44.8, 448)	200 (1.40, 14.0)
1/4 in.		3500 (24.1, 241)	
3/8 in.		1500 (10.3, 103)	
1/2 in.		875 (6.0, 60)	
5/8 in.		500 (3.4, 34)	
3/4 in.		400 (2.8, 28)	
1/8 in.		1-3/4 in.	
3/16 in.	12,000 (82.7, 827)		163 (1.12, 11.2)
1/4 in.	7000 (48.3, 483)		200 (1.40, 14.0)
3/8 in.	3000 (20.6, 206)		
1/2 in.	1750 (12.1, 121)		
5/8 in.	1000 (6.9, 69)		
3/4 in.	800 (5.5, 55)		
1/8 in.	2 in.		
3/16 in.		12,000 (82.7, 827)	125 (0.86, 8.6)
1/4 in.		9500 (65.5, 655)	168 (1.16, 11.6)
3/8 in.		4000 (27.6, 276)	200 (1.40, 14.0)
1/2 in.		2250 (15.5, 155)	
5/8 in.		1500 (10.3, 103)	
3/4 in.		1000 (6.9, 69)	

NOTE: See the **Configuration Number Matrix**, page 4, to find the plunger and air motor size for your unit.

Configuration Number Matrix

Check the identification plate (ID) for the 12-digit Configuration Number of your pump. Use the following matrix to define the components of your pump.

NOTE: Not all combinations are possible.

Sample Configuration Number: PCI-125-19S-XA-A

PCI	125	19	S	X	A	A
Pneumatic Chemical Injection	Air Motor Size	Plunger Size	Pressure Range	Plunger Material	Seal Material	Qualifier









Air Motor Size		Plunger Size		Pressure Range		Plunger Material		Seal Material		Qualifier	
125	1-1/4 inch	13	1/8" Diameter	S	Standard Pressure (1/4", 3/8", 1/2", 5/8", 3/4" plungers)	C	Ceramic Coated 17-4 PH Stainless	A	FKM	A	ATEX
175	1-3/4 inch	19	3/16" Diameter	H	High Pressure (1/8" & 3/16" plung- ers)	X	Chromex Coated 17-4 PH Stainless	B	FKMETP		
200	2 inch	25	1/4" Diameter					C	HNBR		
		38	3/8" Diameter					D	FFKM		
		50	1/2" Diameter								
		63	5/8" Diameter								
		75	3/4" Diameter								

Key Points

- Standard pressure pumps feature 1/4 in. NPT(F) inlet and outlet connections.
- High pressure pumps feature 1/4 in. NPT(F) inlet and HiP HF4 outlet connections.
- B32240 can be used to convert HF4 outlet connection to 1/4 in. NPT(F) for applications 10,000 psi and under.

Warnings

The following warnings are for the setup, use, grounding, maintenance, and repair of this equipment. The exclamation point symbol alerts you to a general warning and the hazard symbols refer to procedure-specific risks. When these symbols appear in the body of this manual or on warning labels, refer back to these Warnings. Product-specific hazard symbols and warnings not covered in this section may appear throughout the body of this manual where applicable.

 <h1 style="margin: 0;">WARNING</h1>	
 	<p>FIRE AND EXPLOSION HAZARD</p> <p>When flammable fluids are present in the work area be aware that flammable fumes can ignite or explode. To help prevent fire and explosion:</p> <ul style="list-style-type: none"> • Use equipment only in well ventilated area. • Eliminate all ignition sources, such as cigarettes and portable electric lamps. • Ground all equipment in the work area. • Keep work area free of debris, including rags and spilled or open containers of solvent. • Do not plug or unplug power cords or turn lights on or off when flammable fumes are present. • Use only grounded hoses. • Stop operation immediately if static sparking occurs or you feel a shock. Do not use equipment until you identify and correct the problem. • Keep a working fire extinguisher in the work area.
    	<p>SKIN INJECTION HAZARD</p> <p>High-pressure fluid from dispensing device, hose leaks, or ruptured components will pierce skin. This may look like just a cut, but it is a serious injury that can result in amputation. Get immediate surgical treatment.</p> <ul style="list-style-type: none"> • Do not put your hand over the fluid outlet. • Do not stop or deflect leaks with your hand, body, glove, or rag. • Follow the Pressure Relief Procedure when you stop dispensing and before cleaning, checking, or servicing equipment. • Tighten all fluid connections before operating the equipment. • Check hoses and couplings daily. Replace worn or damaged parts immediately.
	<p>TOXIC FLUID OR FUMES HAZARD</p> <p>Toxic fluids or fumes can cause serious injury or death if splashed in the eyes or on skin, inhaled, or swallowed.</p> <ul style="list-style-type: none"> • Read Safety Data Sheet (SDS) to know the specific hazards of the fluids you are using. • Store hazardous fluid in approved containers, and dispose of it according to applicable guidelines.

WARNING



PERSONAL PROTECTIVE EQUIPMENT

Wear appropriate protective equipment when in the work area to help prevent serious injury, including eye injury, hearing loss, inhalation of toxic fumes, and burns. Protective equipment includes but is not limited to:

- Protective eyewear, and hearing protection.
- Respirators, protective clothing, and gloves as recommended by the fluid and solvent manufacturer.



EQUIPMENT MISUSE HAZARD

Misuse can cause death or serious injury.

- Do not operate the unit when fatigued or under the influence of drugs or alcohol.
- Do not exceed the maximum working pressure or temperature rating of the lowest rated system component. See **Technical Data** in all equipment manuals.
- Use fluids and solvents that are compatible with equipment wetted parts. See **Technical Data** in all equipment manuals. Read fluid and solvent manufacturer's warnings. For complete information about your material, request Safety Data Sheet (SDS) from distributor or retailer.
- Turn off all equipment and follow the **Pressure Relief Procedure** when equipment is not in use.
- Check equipment regularly. Repair or replace worn or damaged parts immediately with genuine manufacturer's replacement parts only.
- Do not alter or modify equipment. Alterations or modifications may void agency approvals and create safety hazards.
- Make sure all equipment is rated and approved for the environment in which you are using it.
- Use equipment only for its intended purpose. Call your distributor for information.
- Route hoses and cables away from traffic areas, sharp edges, moving parts, and hot surfaces.
- Do not kink or over bend hoses or use hoses to pull equipment.
- Keep children and animals away from work area.
- Comply with all applicable safety regulations.



Component Identification

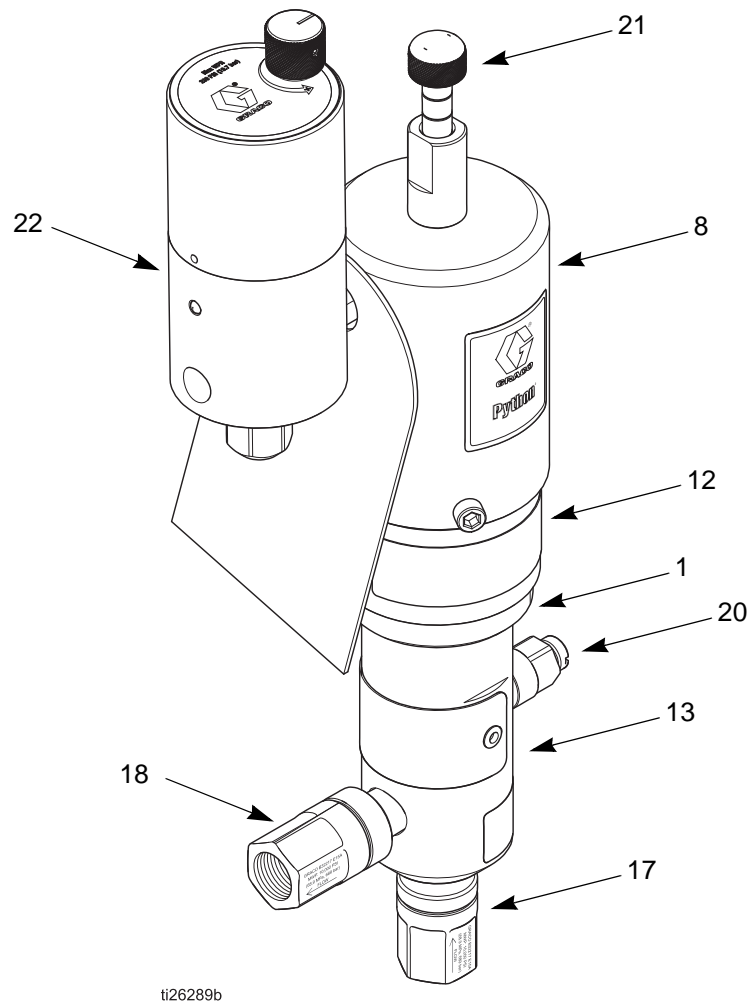

FIG. 1 Pump Components

Numbered items in the key below correspond to the numbers in the Parts Lists starting on page 37.

Key:

- 1 Air Motor Housing
- 8 Air Piston Cylinder
- 12 Dust Shield
- 13 Fluid Cylinder
- 17 Inlet Valve Check
- 18 Outlet Valve Check
- 20 Priming Bleed Valve
- 21 Pump Stroke Adjuster
- 22 Timing Valve

Installation

Grounding



The equipment must be grounded to reduce the risk of static sparking. Static sparking can cause fumes to ignite or explode. Grounding provides an escape wire for the electric current.

Pump: ground through electrically conductive air and fluid lines.

Air and fluid lines: use only electrically conductive lines.

Air compressor: follow manufacturer's recommendations.

Fluid supply container: follow local code.

Required Accessories

Install the following required accessories in the order shown in FIG. 2, using adapters as necessary. See **Kits and Accessories** starting on page 43.

Air Line

- **Bleed-type master air valve (D):** required in your system to relieve air trapped between it and the air motor when the valve is closed.
 - Be sure the valve is easily accessible from the pump and located downstream from the air regulator.
- **Pump air regulator (E):** to control pump speed and outlet pressure. Locate it close to the pump.
- **Air line filter (C):** removes harmful dirt and moisture from compressed air supply.
- **Second bleed-type air valve (air shutoff valve) (B):** isolates air line accessories for servicing. Locate upstream from all other air line accessories.

Fluid Line

- **Fluid filter (Y-Strainer) (included in G):** with a 60 mesh (250 micron) stainless steel element to filter particles from the fluid before it reaches the pump.
- **Fluid shutoff valve (H):** shuts off fluid flow.
- **Pressure relief valve (J):** overload protection.

Flush Before Using Equipment

The equipment was tested with lightweight oil, which is left in the fluid passages to protect parts. To avoid contaminating your fluid with oil, flush the equipment with a compatible solvent before using the equipment. See **Flush the Equipment**, page 17.

Typical Installation

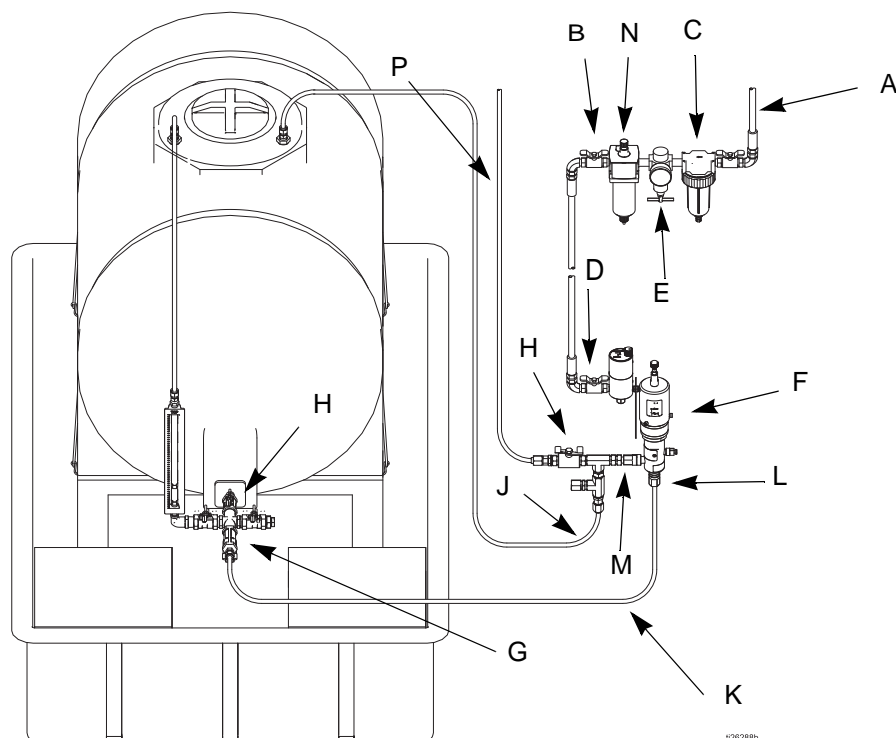

FIG. 2: Typical Installation

FIG. 2 is an example of an installation with a Python chemical injection pump. Your installation may differ from what is shown here. (See **Required Accessories**, page 8.) The Python pump (F) is the only component in FIG. 2 supplied by Graco. All other components are supplied by customer.

Key:

- A Main Air Supply Line
- B Air Shutoff Valve
- C Air Filter
- D Bleed-type Master Air Valve
- E Air Pressure Regulator
- F Pump
- G Manifold Assembly (includes y-strainer and fluid shutoff valve (H))
- H Fluid Shutoff Valve (inlet & outlet)
- J Fluid Pressure Relief Valve
- K Fluid Inlet Line
- L Inlet Port
- M Outlet Port
- N Air Lubricator
- P Fluid Outlet Line

Mount the Pump and Connect Chemical Supply



If you have an application, or mounting configuration, that requires installation in a manner different than depicted in FIG. 2, please contact your Graco distributor for assistance.

NOTE: A y-strainer (G) or chemical filter is required before the pump inlet. This will keep any debris from the tank from reaching the pump seals. Fluid filters are available from Graco. See **Kits and Accessories** on page 43.

1. Mount the pump (F) and connect the fluid inlet line (K).

The pump is designed to be vertically mounted directly from the 1/4 female NPT inlet port (L). The inlet port (L) is on the bottom and is designated by a flow arrow pointing into the pump. Verify the inlet plumbing is sufficiently strong to support the weight of the pump.

Connect Pneumatic Supply

1. Install the pneumatic regulator (E) and gauge to control the inlet pressure. See **Models** on page 3 for your model's maximum pneumatic pressure.

NOTE: If less than 200 psi supply pressure is used, the pump's maximum output pressure will be decreased proportionally. See **Minimum Gas Pressures by Fluid Plunger Size and Outlet Pressures** on page 11. Minimum Gas Pressure can be found by first finding the table that corresponds to the plunger size. Next, using the column that corresponds to the air motor size, find the row equal to or slightly greater than the outlet pressure of the pump. The value is the Minimum Gas Pressure required to achieve the fluid outlet pressure.

2. Install a pneumatic line filter (C) to keep debris from affecting pump performance and to increase pump life.

NOTE: Keep the timing valve knob closed at this point to keep the pump from operating without fluid, which minimizes seal wear.

3. Attach a pneumatic line to the 1/8 in. female NPT port (116) on the timing valve. (See **Python Timing Valve Assembly**, page 41.) An 1/8 in. NPT fitting is preferred, though a 1/8 in. - 1/4 in. NPT adapter is included for convenience.

Connect Chemical Outlet

1. Connect a 1/4 npt(f) fluid line from the outlet check valve (M) to the injection point.

NOTE: On high pressure configurations (PCI-xxx-xxH-xx-x), the 1/4 npt(f) fitting is replaced with an HiP HF4 fitting.

2. Install a pressure relief valve (J) on the outlet side of the pump.

NOTE: A pressure relief valve is available from Graco and can be connected back to the tank or directly to the inlet side of the pump. See **Kits and Accessories** on page 43.



In the event of an injection line blockage, to reduce the risk of skin injection and damage to the pump, ensure the pressure relief valve is set at or below the maximum working pressure of the pump.

3. Set the pressure relief valve at or below the maximum working pressure of the pump.
4. Connect a 10-32 UNF fluid outlet from the prime/bleed valve (21) to the fluid source or waste reservoir.

NOTE: On high pressure configurations (PCI-xxx-xxH-xx-x), the 10-32 fitting is replaced with a 1/16 in. NPT(F) fitting.

Minimum Gas Pressures by Fluid Plunger Size and Outlet Pressures

See **Performance Charts**, starting on page 45, for maximum flows at any given pressure.

Outlet Pressure psi (MPa, bar)	1/8 in. Fluid Plunger Pumps			3/16 in. Fluid Plunger Pumps		
	Minimum Gas Pressure psi (MPa, bar)			Minimum Gas Pressure psi (MPa, bar)		
	1.25 in. Air Motor	1.75 in. Air Motor	2 in. Air Motor	1.25 in. Air Motor	1.75 in. Air Motor	2 in. Air Motor
0 (0, 0)	50 (0.34, 3.4)	50 (0.34, 3.4)	50 (0.34, 3.4)	50 (0.34, 3.4)	50 (0.34, 3.4)	50 (0.34, 3.4)
250 (1.7, 17.2)	52 (0.36, 3.6)	50 (0.34, 3.4)	50 (0.34, 3.4)	55 (0.38, 3.8)	50 (0.34, 3.4)	50 (0.34, 3.4)
500 (3.4, 34.5)	55 (0.38, 3.8)	50 (0.34, 3.4)	50 (0.34, 3.4)	61 (0.42, 4.2)	50 (0.34, 3.4)	50 (0.34, 3.4)
750 (5.2, 51.7)	57 (0.39, 3.9)	50 (0.34, 3.4)	50 (0.34, 3.4)	67 (0.46, 4.6)	50 (0.34, 3.4)	50 (0.34, 3.4)
1000 (6.9, 68.9)	60 (0.41, 4.1)	50 (0.34, 3.4)	50 (0.34, 3.4)	72 (0.50, 5.0)	50 (0.34, 3.4)	50 (0.34, 3.4)
1250 (8.6, 86.2)	62 (0.43, 4.3)	50 (0.34, 3.4)	50 (0.34, 3.4)	78 (0.54, 5.4)	50 (0.34, 3.4)	50 (0.34, 3.4)
1500 (10.3, 103.4)	65 (0.45, 4.5)	50 (0.34, 3.4)	50 (0.34, 3.4)	83 (0.58, 5.8)	50 (0.34, 3.4)	50 (0.34, 3.4)
1750 (12.1, 120.7)	67 (0.46, 4.6)	50 (0.34, 3.4)	50 (0.34, 3.4)	89 (0.61, 6.1)	50 (0.34, 3.4)	50 (0.34, 3.4)
2000 (13.8, 137.9)	70 (0.48, 4.8)	50 (0.34, 3.4)	50 (0.34, 3.4)	95 (0.65, 6.5)	50 (0.34, 3.4)	50 (0.34, 3.4)
2250 (15.5, 155.1)	72 (0.50, 5.0)	50 (0.34, 3.4)	50 (0.34, 3.4)	100 (0.69, 6.9)	51 (0.35, 3.5)	50 (0.34, 3.4)
2500 (17.2, 172.4)	75 (0.52, 5.2)	50 (0.34, 3.4)	50 (0.34, 3.4)	106 (0.73, 7.3)	54 (0.37, 3.7)	50 (0.34, 3.4)
2750 (19, 189.6)	77 (0.53, 5.3)	50 (0.34, 3.4)	50 (0.34, 3.4)	112 (0.77, 7.7)	57 (0.39, 3.9)	50 (0.34, 3.4)
3000 (20.7, 206.8)	80 (0.55, 5.5)	50 (0.34, 3.4)	50 (0.34, 3.4)	117 (0.81, 8.1)	60 (0.41, 4.1)	50 (0.34, 3.4)
3250 (22.4, 224.1)	82 (0.57, 5.7)	50 (0.34, 3.4)	50 (0.34, 3.4)	123 (0.85, 8.5)	63 (0.43, 4.3)	50 (0.34, 3.4)
3500 (24.1, 241.3)	85 (0.58, 5.8)	50 (0.34, 3.4)	50 (0.34, 3.4)	128 (0.89, 8.9)	66 (0.45, 4.5)	50 (0.35, 3.5)
3750 (25.9, 258.6)	87 (0.60, 6.0)	50 (0.34, 3.4)	50 (0.34, 3.4)	134 (0.92, 9.2)	68 (0.47, 4.7)	52 (0.36, 3.6)
4000 (27.6, 275.8)	90 (0.62, 6.2)	50 (0.34, 3.4)	50 (0.34, 3.4)	140 (0.96, 9.6)	71 (0.49, 4.9)	55 (0.38, 3.8)
4250 (29.3, 293)	92 (0.64, 6.4)	50 (0.34, 3.4)	50 (0.34, 3.4)	145 (1.00, 10.0)	74 (0.51, 5.1)	57 (0.39, 3.9)
4500 (31, 310.3)	95 (0.65, 6.5)	50 (0.34, 3.4)	50 (0.34, 3.4)	151 (1.04, 10.4)	77 (0.53, 5.3)	59 (0.41, 4.1)
4750 (32.8, 327.5)	97 (0.67, 6.7)	50 (0.34, 3.4)	50 (0.34, 3.4)	157 (1.08, 10.8)	80 (0.55, 5.5)	61 (0.42, 4.2)
5000 (34.5, 344.7)	100 (0.69, 6.9)	51 (0.35, 3.5)	50 (0.34, 3.4)	162 (1.12, 11.2)	83 (0.57, 5.7)	63 (0.44, 4.4)
5250 (36.2, 362)	102 (0.70, 7.0)	52 (0.36, 3.6)	50 (0.34, 3.4)	168 (1.16, 11.6)	86 (0.59, 5.9)	66 (0.45, 4.5)
5500 (37.9, 379.2)	105 (0.72, 7.2)	53 (0.37, 3.7)	50 (0.34, 3.4)	173 (1.20, 12.0)	88 (0.61, 6.1)	68 (0.47, 4.7)
5750 (39.6, 396.4)	107 (0.74, 7.4)	55 (0.38, 3.8)	50 (0.34, 3.4)	179 (1.23, 12.3)	91 (0.63, 6.3)	70 (0.48, 4.8)
6000 (41.4, 413.7)	110 (0.76, 7.6)	56 (0.39, 3.9)	50 (0.34, 3.4)	185 (1.27, 12.7)	94 (0.65, 6.5)	72 (0.50, 5.0)
6250 (43.1, 430.9)	112 (0.77, 7.7)	57 (0.39, 3.9)	50 (0.34, 3.4)	190 (1.31, 13.1)	97 (0.67, 6.7)	74 (0.51, 5.1)
6500 (44.8, 448.2)	115 (0.79, 7.9)	59 (0.40, 4.0)	50 (0.34, 3.4)	196 (1.35, 13.5)	100 (0.69, 6.9)	77 (0.53, 5.3)
6750 (46.5, 465.4)	117 (0.81, 8.1)	60 (0.41, 4.1)	50 (0.34, 3.4)		103 (0.71, 7.1)	79 (0.54, 5.4)
7000 (48.3, 482.6)	120 (0.83, 8.3)	61 (0.42, 4.2)	50 (0.34, 3.4)		106 (0.73, 7.3)	81 (0.56, 5.6)
7250 (50, 499.9)	122 (0.84, 8.4)	62 (0.43, 4.3)	50 (0.34, 3.4)		109 (0.75, 7.5)	83 (0.57, 5.7)
7500 (51.7, 517.1)	125 (0.86, 8.6)	64 (0.44, 4.4)	50 (0.34, 3.4)		111 (0.77, 7.7)	85 (0.59, 5.9)
7750 (53.4, 534.3)	127 (0.88, 8.8)	65 (0.45, 4.5)	50 (0.34, 3.4)		114 (0.79, 7.9)	88 (0.60, 6.0)
8000 (55.2, 551.6)	130 (0.89, 8.9)	66 (0.46, 4.6)	51 (0.35, 3.5)		117 (0.81, 8.1)	90 (0.62, 6.2)
8250 (56.9, 568.8)	132 (0.91, 9.1)	67 (0.47, 4.7)	52 (0.36, 3.6)		120 (0.83, 8.3)	92 (0.63, 6.3)
8500 (58.6, 586.1)	135 (0.93, 9.3)	69 (0.47, 4.7)	53 (0.36, 3.6)		123 (0.85, 8.5)	94 (0.65, 6.5)
8750 (60.3, 603.3)	137 (0.95, 9.5)	70 (0.48, 4.8)	54 (0.37, 3.7)		126 (0.87, 8.7)	96 (0.66, 6.6)
9000 (62.1, 620.5)	140 (0.96, 9.6)	71 (0.49, 4.9)	55 (0.38, 3.8)		129 (0.89, 8.9)	99 (0.68, 6.8)
9250 (63.8, 637.8)	142 (0.98, 9.8)	73 (0.50, 5.0)	56 (0.38, 3.8)		132 (0.91, 9.1)	101 (0.69, 6.9)
9500 (65.5, 655)	145 (1.00, 10.0)	74 (0.51, 5.1)	57 (0.39, 3.9)		134 (0.93, 9.3)	103 (0.71, 7.1)
9750 (67.2, 672.2)	147 (1.01, 10.1)	75 (0.52, 5.2)	58 (0.40, 4.0)		137 (0.95, 9.5)	105 (0.72, 7.2)
10000 (68.9, 689.5)	150 (1.03, 10.3)	76 (0.53, 5.3)	58 (0.40, 4.0)		140 (0.97, 9.7)	107 (0.74, 7.4)
10250 (70.7, 706.7)	152 (1.05, 10.5)	78 (0.54, 5.4)	59 (0.41, 4.1)		143 (0.99, 9.9)	110 (0.76, 7.6)
10500 (72.4, 723.9)	155 (1.07, 10.7)	79 (0.54, 5.4)	60 (0.42, 4.2)		146 (1.01, 10.1)	112 (0.77, 7.7)
10750 (74.1, 741.2)	157 (1.08, 10.8)	80 (0.55, 5.5)	61 (0.42, 4.2)		149 (1.03, 10.3)	114 (0.79, 7.9)
11000 (75.8, 758.4)	160 (1.10, 11.0)	81 (0.56, 5.6)	62 (0.43, 4.3)		152 (1.05, 10.5)	116 (0.80, 8.0)
11250 (77.6, 775.7)	162 (1.12, 11.2)	83 (0.57, 5.7)	63 (0.44, 4.4)		155 (1.07, 10.7)	118 (0.82, 8.2)
11500 (79.3, 792.9)	165 (1.14, 11.4)	84 (0.58, 5.8)	64 (0.44, 4.4)		157 (1.09, 10.9)	120 (0.83, 8.3)
12000 (82.7, 827.4)	170 (1.17, 11.7)	87 (0.60, 6.0)	66 (0.46, 4.6)		163 (1.12, 11.2)	125 (0.86, 8.6)

Outlet Pressure psi (MPa, bar)	1/4 in. Fluid Plunger Pumps		
	Minimum Gas Pressure psi (MPa, bar)		
	1.25 in. Air Motor	1.75 in. Air Motor	2 in. Air Motor
0 (0, 0)	50 (0.34, 3.4)	50 (0.34, 3.4)	50 (0.34, 3.4)
250 (1.7, 17.2)	60 (0.41, 4.1)	50 (0.34, 3.4)	50 (0.34, 3.4)
500 (3.4, 34.5)	70 (0.48, 4.8)	50 (0.34, 3.4)	50 (0.34, 3.4)
750 (5.2, 51.7)	80 (0.55, 5.5)	50 (0.34, 3.4)	50 (0.34, 3.4)
1000 (6.9, 68.9)	90 (0.62, 6.2)	50 (0.34, 3.4)	50 (0.34, 3.4)
1250 (8.6, 86.2)	100 (0.69, 6.9)	51 (0.35, 3.5)	50 (0.34, 3.4)
1500 (10.3, 103.4)	110 (0.76, 7.6)	56 (0.39, 3.9)	50 (0.34, 3.4)
1750 (12.1, 120.7)	120 (0.83, 8.3)	61 (0.42, 4.2)	50 (0.34, 3.4)
2000 (13.8, 137.9)	130 (0.89, 8.9)	66 (0.46, 4.6)	51 (0.35, 3.5)
2250 (15.5, 155.1)	140 (0.96, 9.6)	71 (0.49, 4.9)	55 (0.38, 3.8)
2500 (17.2, 172.4)	150 (1.03, 10.3)	76 (0.53, 5.3)	58 (0.40, 4.0)
2750 (19, 189.6)	160 (1.10, 11.0)	81 (0.56, 5.6)	62 (0.43, 4.3)
3000 (20.7, 206.8)	170 (1.17, 11.7)	87 (0.60, 6.0)	66 (0.46, 4.6)
3250 (22.4, 224.1)	180 (1.24, 12.4)	92 (0.63, 6.3)	70 (0.48, 4.8)
3500 (24.1, 241.3)	190 (1.31, 13.1)	97 (0.67, 6.7)	74 (0.51, 5.1)
3750 (25.9, 258.6)	200 (1.38, 13.8)	102 (0.70, 7.0)	78 (0.54, 5.4)
4000 (27.6, 275.8)	-	107 (0.74, 7.4)	82 (0.56, 5.6)
4250 (29.3, 293)	-	112 (0.77, 7.7)	86 (0.59, 5.9)
4500 (31, 310.3)	-	117 (0.81, 8.1)	90 (0.62, 6.2)
4750 (32.8, 327.5)	-	122 (0.84, 8.4)	94 (0.65, 6.5)
5000 (34.5, 344.7)	-	127 (0.88, 8.8)	98 (0.67, 6.7)
5250 (36.2, 362)	-	133 (0.91, 9.1)	101 (0.70, 7.0)
5500 (37.9, 379.2)	-	138 (0.95, 9.5)	105 (0.73, 7.3)
5750 (39.6, 396.4)	-	143 (0.98, 9.8)	109 (0.75, 7.5)
6000 (41.4, 413.7)	-	148 (1.02, 10.2)	113 (0.78, 7.8)
6250 (43.1, 430.9)	-	153 (1.05, 10.5)	117 (0.81, 8.1)
6500 (44.8, 448.2)	-	158 (1.09, 10.9)	121 (0.83, 8.3)
6750 (46.5, 465.4)	-	163 (1.12, 11.2)	125 (0.86, 8.6)
7000 (48.3, 482.6)	-	168 (1.16, 11.6)	129 (0.89, 8.9)
7250 (50, 499.9)	-	173 (1.19, 11.9)	133 (0.91, 9.1)
7500 (51.7, 517.1)	-	178 (1.23, 12.3)	137 (0.94, 9.4)
7750 (53.4, 534.3)	-	184 (1.27, 12.7)	141 (0.97, 9.7)
8000 (55.2, 551.6)	-	189 (1.30, 13.0)	144 (1.00, 10.0)
8250 (56.9, 568.8)	-	194 (1.34, 13.4)	148 (1.02, 10.2)
8500 (58.6, 586.1)	-	199 (1.37, 13.7)	152 (1.05, 10.5)
8750 (60.3, 603.3)	-	-	156 (1.08, 10.8)
9000 (62.1, 620.5)	-	-	160 (1.10, 11.0)
9250 (63.8, 637.8)	-	-	164 (1.13, 11.3)
9500 (65.5, 655)	-	-	168 (1.16, 11.6)

Outlet Pressure psi (MPa, bar)	3/8 in. Fluid Plunger Pumps		
	Minimum Gas Pressure psi (MPa, bar)		
	1.25 in. Air Motor	1.75 in. Air Motor	2 in. Air Motor
0 (0, 0)	50 (0.34, 3.4)	50 (0.34, 3.4)	50 (0.34, 3.4)
150 (1, 10.3)	63 (0.44, 4.4)	50 (0.34, 3.4)	50 (0.34, 3.4)
300 (2.1, 20.7)	77 (0.53, 5.3)	50 (0.34, 3.4)	50 (0.34, 3.4)
450 (3.1, 31)	90 (0.62, 6.2)	46 (0.32, 3.2)	50 (0.34, 3.4)
600 (4.1, 41.4)	104 (0.72, 7.2)	53 (0.36, 3.6)	41 (0.28, 2.8)
750 (5.2, 51.7)	117 (0.81, 8.1)	60 (0.41, 4.1)	46 (0.32, 3.2)
900 (6.2, 62.1)	131 (0.90, 9.0)	67 (0.46, 4.6)	51 (0.35, 3.5)
1050 (7.2, 72.4)	144 (0.99, 9.9)	74 (0.51, 5.1)	56 (0.39, 3.9)
1200 (8.3, 82.7)	158 (1.09, 10.9)	80 (0.55, 5.5)	62 (0.42, 4.2)
1350 (9.3, 93.1)	171 (1.18, 11.8)	87 (0.60, 6.0)	67 (0.46, 4.6)
1500 (10.3, 103.4)	185 (1.27, 12.7)	94 (0.65, 6.5)	72 (0.50, 5.0)
1650 (11.4, 113.8)	198 (1.37, 13.7)	101 (0.70, 7.0)	77 (0.53, 5.3)
1800 (12.4, 124.1)	-	108 (0.74, 7.4)	83 (0.57, 5.7)
1950 (13.4, 134.4)	-	115 (0.79, 7.9)	88 (0.61, 6.1)
2100 (14.5, 144.8)	-	122 (0.84, 8.4)	93 (0.64, 6.4)
2250 (15.5, 155.1)	-	129 (0.89, 8.9)	99 (0.68, 6.8)
2400 (16.5, 165.5)	-	136 (0.93, 9.3)	104 (0.72, 7.2)
2550 (17.6, 175.8)	-	142 (0.98, 9.8)	109 (0.75, 7.5)
2700 (18.6, 186.2)	-	149 (1.03, 10.3)	114 (0.79, 7.9)
2850 (19.7, 196.5)	-	156 (1.08, 10.8)	120 (0.82, 8.2)
3000 (20.7, 206.8)	-	163 (1.12, 11.2)	125 (0.86, 8.6)
3150 (21.7, 217.2)	-	170 (1.17, 11.7)	130 (0.90, 9.0)
3300 (22.8, 227.5)	-	177 (1.22, 12.2)	135 (0.93, 9.3)
3450 (23.8, 237.9)	-	184 (1.27, 12.7)	141 (0.97, 9.7)
3600 (24.8, 248.2)	-	191 (1.31, 13.1)	146 (1.01, 10.1)
3750 (25.9, 258.6)	-	198 (1.36, 13.6)	151 (1.04, 10.4)
3900 (26.9, 268.9)	-	-	157 (1.08, 10.8)
4050 (27.9, 279.2)	-	-	162 (1.12, 11.2)
4200 (29.0, 289.6)	-	-	167 (1.15, 11.5)
4350 (30.0, 299.9)	-	-	172 (1.19, 11.9)
4500 (31.0, 310.3)	-	-	178 (1.22, 12.2)
4650 (32.1, 320.6)	-	-	183 (1.26, 12.6)
4800 (33.1, 330.9)	-	-	188 (1.30, 13.0)
4950 (34.1, 341.3)	-	-	193 (1.33, 13.3)
5100 (35.2, 351.6)	-	-	199 (1.37, 13.7)

Outlet Pressure psi (MPa, bar)	1/2 in. Fluid Plunger Pumps		
	Minimum Gas Pressure psi (MPa, bar)		
	1.25 in. Air Motor	1.75 in. Air Motor	2 in. Air Motor
0 (0, 0)	50 (0.34, 3.4)	50 (0.34, 3.4)	50 (0.34, 3.4)
100 (0.7, 6.9)	66 (0.45, 4.5)	50 (0.34, 3.4)	50 (0.34, 3.4)
200 (1.4, 13.8)	82 (0.56, 5.6)	50 (0.34, 3.4)	50 (0.34, 3.4)
300 (2.1, 20.7)	98 (0.67, 6.7)	50 (0.34, 3.4)	50 (0.34, 3.4)
400 (2.8, 27.6)	114 (0.78, 7.8)	58 (0.40, 4.0)	50 (0.34, 3.4)
500 (3.4, 34.5)	130 (0.89, 8.9)	66 (0.46, 4.6)	51 (0.35, 3.5)
600 (4.1, 41.4)	146 (1.00, 10.0)	74 (0.51, 5.1)	57 (0.39, 3.9)
700 (4.8, 48.3)	162 (1.11, 11.1)	83 (0.57, 5.7)	63 (0.44, 4.4)
800 (5.5, 55.2)	178 (1.23, 12.3)	91 (0.63, 6.3)	69 (0.48, 4.8)
900 (6.2, 62.1)	194 (1.34, 13.4)	99 (0.68, 6.8)	76 (0.52, 5.2)
1000 (6.9, 68.9)	-	107 (0.74, 7.4)	82 (0.56, 5.6)
1100 (7.6, 75.8)	-	115 (0.79, 7.9)	88 (0.61, 6.1)
1200 (8.3, 82.7)	-	123 (0.85, 8.5)	94 (0.65, 6.5)
1300 (9, 89.6)	-	131 (0.91, 9.1)	101 (0.69, 6.9)
1400 (9.7, 96.5)	-	140 (0.96, 9.6)	107 (0.74, 7.4)
1500 (10.3, 103.4)	-	148 (1.02, 10.2)	113 (0.78, 7.8)
1600 (11, 110.3)	-	156 (1.08, 10.8)	119 (0.82, 8.2)
1700 (11.7, 117.2)	-	164 (1.13, 11.3)	126 (0.87, 8.7)
1800 (12.4, 124.1)	-	172 (1.19, 11.9)	132 (0.91, 9.1)
1900 (13.1, 131)	-	180 (1.24, 12.4)	138 (0.95, 9.5)
2000 (13.8, 137.9)	-	189 (1.30, 13.0)	144 (1.00, 10.0)
2100 (14.5, 144.8)	-	197 (1.36, 13.6)	151 (1.04, 10.4)
2200 (15.2, 151.7)	-	-	157 (1.08, 10.8)
2300 (15.9, 158.6)	-	-	163 (1.12, 11.2)
2400 (16.5, 165.5)	-	-	169 (1.17, 11.7)
2500 (17.2, 172.4)	-	-	176 (1.21, 12.1)
2600 (17.9, 179.3)	-	-	182 (1.25, 12.5)
2700 (18.6, 186.2)	-	-	188 (1.30, 13.0)
2800 (19.3, 193.1)	-	-	194 (1.34, 13.4)

Outlet Pressure psi (MPa, bar)	5/8 in. Fluid Plunger Pumps		
	Minimum Gas Pressure psi (MPa, bar)		
	1.25 in. Air Motor	1.75 in. Air Motor	2 in. Air Motor
0 (0, 0)	50 (0.34, 3.4)	50 (0.34, 3.4)	50 (0.34, 3.4)
75 (0.5, 5.2)	68 (0.47, 4.7)	50 (0.34, 3.4)	50 (0.34, 3.4)
150 (1, 10.3)	87 (0.60, 6.0)	50 (0.34, 3.4)	50 (0.34, 3.4)
225 (1.6, 15.5)	106 (0.73, 7.3)	54 (0.37, 3.7)	50 (0.34, 3.4)
300 (2.1, 20.7)	125 (0.86, 8.6)	64 (0.44, 4.4)	50 (0.34, 3.4)
375 (2.6, 25.9)	143 (0.99, 9.9)	73 (0.50, 5.0)	56 (0.39, 3.9)
450 (3.1, 31)	162 (1.12, 11.2)	83 (0.57, 5.7)	63 (0.44, 4.4)
525 (3.6, 36.2)	181 (1.25, 12.5)	92 (0.64, 6.4)	71 (0.49, 4.9)
600 (4.1, 41.4)	200 (1.38, 13.8)	102 (0.70, 7.0)	78 (0.54, 5.4)
675 (4.7, 46.5)	-	111 (0.77, 7.7)	85 (0.59, 5.9)
750 (5.2, 51.7)	-	121 (0.83, 8.3)	93 (0.64, 6.4)
825 (5.7, 56.9)	-	131 (0.90, 9.0)	100 (0.69, 6.9)
900 (6.2, 62.1)	-	140 (0.97, 9.7)	107 (0.74, 7.4)
975 (6.7, 67.2)	-	150 (1.03, 10.3)	115 (0.79, 7.9)
1050 (7.2, 72.4)	-	159 (1.10, 11.0)	122 (0.84, 8.4)
1125 (7.8, 77.6)	-	169 (1.16, 11.6)	129 (0.89, 8.9)
1200 (8.3, 82.7)	-	178 (1.23, 12.3)	137 (0.94, 9.4)
1275 (8.8, 87.9)	-	188 (1.30, 13.0)	144 (0.99, 9.9)
1350 (9.3, 93.1)	-	198 (1.36, 13.6)	151 (1.04, 10.4)
1425 (9.8, 98.3)	-	-	159 (1.09, 10.9)
1500 (10.3, 103.4)	-	-	166 (1.14, 11.4)
1575 (10.9, 108.6)	-	-	173 (1.19, 11.9)
1650 (11.4, 113.8)	-	-	181 (1.24, 12.4)
1725 (11.9, 118.9)	-	-	188 (1.30, 13.0)
1800 (12.4, 124.1)	-	-	195 (1.35, 13.5)

Outlet Pressure psi (MPa, bar)	3/4 in. Fluid Plunger Pumps		
	Minimum Gas Pressure psi (MPa, bar)		
	1.25 in. Air Motor	1.75 in. Air Motor	2 in. Air Motor
0 (0, 0)	50 (0.34, 3.4)	50 (0.34, 3.4)	50 (0.34, 3.4)
50 (0.3, 3.4)	68 (0.47, 4.7)	50 (0.34, 3.4)	50 (0.34, 3.4)
100 (0.7, 6.9)	86 (0.59, 5.9)	44 (0.30, 3.0)	50 (0.34, 3.4)
150 (1, 10.3)	104 (0.72, 7.2)	53 (0.36, 3.6)	41 (0.28, 2.8)
200 (1.4, 13.8)	122 (0.84, 8.4)	62 (0.43, 4.3)	48 (0.33, 3.3)
250 (1.7, 17.2)	140 (0.96, 9.6)	71 (0.49, 4.9)	55 (0.38, 3.8)
300 (2.1, 20.7)	158 (1.09, 10.9)	80 (0.55, 5.5)	62 (0.42, 4.2)
350 (2.4, 24.1)	176 (1.21, 12.1)	90 (0.62, 6.2)	69 (0.47, 4.7)
400 (2.8, 27.6)	194 (1.34, 13.4)	99 (0.68, 6.8)	76 (0.52, 5.2)
450 (3.1, 31)		108 (0.74, 7.4)	83 (0.57, 5.7)
500 (3.4, 34.5)	-	117 (0.81, 8.1)	90 (0.62, 6.2)
550 (3.8, 37.9)	-	126 (0.87, 8.7)	97 (0.67, 6.7)
600 (4.1, 41.4)	-	136 (0.93, 9.3)	104 (0.72, 7.2)
650 (4.5, 44.8)	-	145 (1.00, 10.0)	111 (0.76, 7.6)
700 (4.8, 48.3)	-	154 (1.06, 10.6)	118 (0.81, 8.1)
750 (5.2, 51.7)	-	163 (1.12, 11.2)	125 (0.86, 8.6)
800 (5.5, 55.2)	-	172 (1.19, 11.9)	132 (0.91, 9.1)
850 (5.9, 58.6)	-	181 (1.25, 12.5)	139 (0.96, 9.6)
900 (6.2, 62.1)	-	191 (1.31, 13.1)	146 (1.01, 10.1)
950 (6.6, 65.5)	-	200 (1.38, 13.8)	153 (1.05, 10.5)
1000 (6.9, 68.9)	-	-	160 (1.10, 11.0)
1050 (7.2, 72.4)	-	-	167 (1.15, 11.5)
1100 (7.6, 75.8)	-	-	174 (1.20, 12.0)
1150 (7.9, 79.3)	-	-	181 (1.25, 12.5)
1200 (8.3, 82.7)	-	-	188 (1.30, 13.0)
1250 (8.6, 86.2)	-	-	195 (1.35, 13.5)

Operation

Pressure Relief Procedure

 Follow the Pressure Relief Procedure whenever you see this symbol.



This equipment stays pressurized until pressure is manually relieved. To help prevent serious injury from pressurized fluid, such as skin injection and splashing fluid, follow the **Pressure Relief Procedure** when you stop dispensing and before cleaning, checking, or servicing the equipment.

NOTE: Always discharge fluid into an approved container or location.

1. Shut off all fluid and air lines (A, K, & P) using shut-off valves (H).
2. Disconnect air supply lines (A).
3. Disconnect timing valve (22) to vent internal trapped pressure.

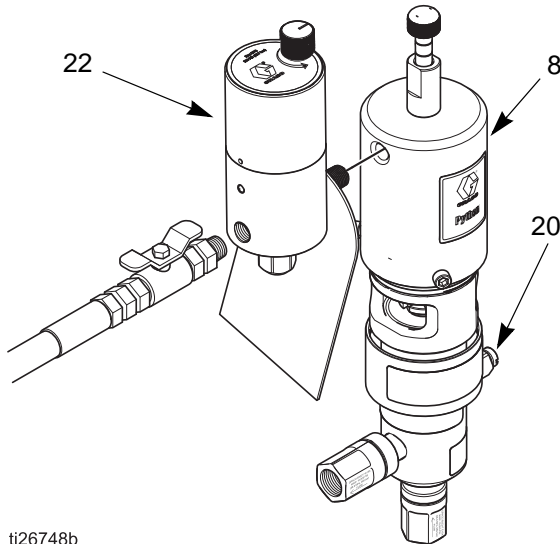

ti26748b

FIG. 3 Disconnect timing valve

4. Use a flathead screwdriver to turn the prime/bleed valve (20) slowly counter-clockwise to relieve pres-

sure. (Use a hex wrench for PCI-xxx-xxH pumps. See **Configuration Number Matrix**, page 4.)

5. Slowly disconnect fluid lines (K & P) from check valves (L & M).
6. Reconnect timing valve (22).

Flush the Equipment

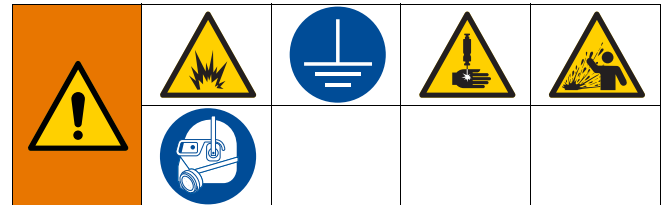

To avoid fire and explosion, always ground equipment and waste container. To avoid static sparking and injury from splashing, always flush at the lowest possible pressure.

- Flush with a fluid that is compatible with the fluid being dispensed and the equipment wetted parts.
1. Follow the **Pressure Relief Procedure**.
 2. Connect inlet to the supply source of the flushing fluid.
 3. Connect outlet to a waste reservoir.
 4. Run the pump until the dispensed fluid is predominately flushing fluid.
 5. Follow the **Pressure Relief Procedure**.

Prime the Pump



1. Verify all connections and fluid lines are tight.
2. In order to prime the pump, turn the prime valve (20) counter-clockwise.

NOTE: PCI-xxx-xxH pumps feature a one-piece valve (19) that requires a hex wrench to turn. See **Configuration Number Matrix**, page 4.

3. Turn the timing valve knob (122) located on the timing valve (22) counter-clockwise slowly. This will turn the pneumatic supply on to the pump and begin cycling.
4. Keep the pump cycle rate less than 1 cycle every 3 seconds. The pump is primed when discharge from the prime valve (20) has transitioned from air, to bubbly liquid chemical, to pure liquid chemical.
5. Close the prime valve (20) tightly and verify that fluid has stopped draining from the port.

NOTE: PCI-xxx-xxH pumps feature a one-piece valve (19) that requires a hex wrench turn.

Calibrate Chemical Dosage



1. Begin the process by setting the timing valve (22) to an estimated setting of the flow rate. See **Baseline Chemical Dosage Settings**, page 20, for tables of cycles per minute (CPM), and corresponding gallons per day (GPD) and liters per day (LPD).

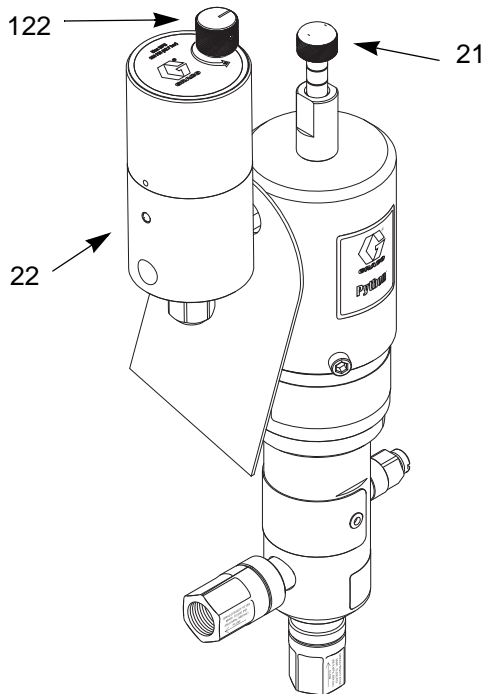

ti26289b

Fig. 4 Calibrate Chemical Dosage

2. Follow the instructions provided with your calibration gauge in conjunction with the **Baseline Chemical Dosage Settings** on page 20.
3. Adjust the timing valve (22) accordingly after the test is performed. Turning the knob (122) counter-clockwise will increase the pump flow rate, while turning the knob clockwise will decrease the flow.
4. Repeat the test procedure to verify your changes. Repeat as necessary until the desired flow rate is achieved.

Stroke Adjustment

This pump has infinite stroke adjustment between full and 1/4 stroke, and has four marked stroke adjustment positions.

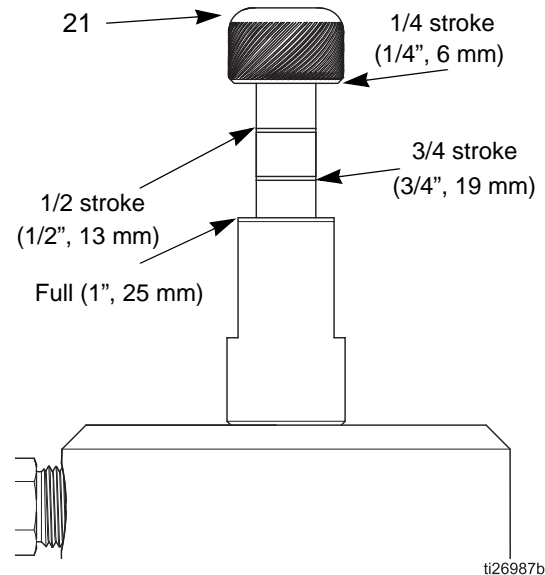

ti26987b

Fig. 5 Stroke adjustment settings

- To increase the stroke length, turn the stroke adjustment knob (21) counter-clockwise.
- To decrease the stroke length, turn the stroke adjustment knob (21) clockwise.

Baseline Chemical Dosage Settings

See **Stroke Adjustment**, page 19, for stroke adjust settings. See **Performance Charts**, starting on page 45, for maximum flows at any given pressure.

CPM	1/8 in. Fluid Plunger Pumps				3/16 in. Fluid Plunger Pumps			
	GPD (LPD)				GPD (LPD)			
	Full Stroke	3/4 Stroke	1/2 Stroke	1/4 Stroke	Full Stroke	3/4 Stroke	1/2 Stroke	1/4 Stroke
5	0.3 (1.1)	0.2 (0.8)	0.1 (0.5)	0.1 (0.3)	0.6 (2.4)	0.5 (1.8)	0.3 (1.2)	0.2 (0.6)
10	0.6 (2.2)	0.4 (1.6)	0.3 (1.1)	0.1 (0.5)	1.3 (4.9)	1.0 (3.7)	0.6 (2.4)	0.3 (1.2)
15	0.9 (3.3)	0.6 (2.4)	0.4 (1.6)	0.2 (0.8)	1.9 (7.3)	1.5 (5.5)	1.0 (3.7)	0.5 (1.8)
20	1.1 (4.3)	0.9 (3.3)	0.6 (2.2)	0.3 (1.1)	2.6 (9.8)	1.9 (7.3)	1.3 (4.9)	0.6 (2.4)
25	1.4 (5.4)	1.1 (4.1)	0.7 (2.7)	0.4 (1.4)	3.2 (12.2)	2.4 (9.2)	1.6 (6.1)	0.8 (3.1)
30	1.7 (6.5)	1.3 (4.9)	0.9 (3.3)	0.4 (1.6)	3.9 (14.7)	2.9 (11)	1.9 (7.3)	1.0 (3.7)
35	2.0 (7.6)	1.5 (5.7)	1.0 (3.8)	0.5 (1.9)	4.5 (17.1)	3.4 (12.8)	2.3 (8.6)	1.1 (4.3)
40	2.3 (8.7)	1.7 (6.5)	1.1 (4.3)	0.6 (2.2)	5.2 (19.5)	3.9 (14.7)	2.6 (9.8)	1.3 (4.9)
45	2.6 (9.8)	1.9 (7.3)	1.3 (4.9)	0.6 (2.4)	5.8 (22.0)	4.4 (16.5)	2.9 (11.0)	1.5 (5.5)
50	2.9 (10.9)	2.2 (8.1)	1.4 (5.4)	0.7 (2.7)	6.5 (24.4)	4.8 (18.3)	3.2 (12.2)	1.6 (6.1)
55	3.2 (11.9)	2.4 (9.0)	1.6 (6.0)	0.8 (3.0)	7.1 (26.9)	5.3 (20.2)	3.6 (13.4)	1.8 (6.7)
60	3.4 (13.0)	2.6 (9.8)	1.7 (6.5)	0.9 (3.3)	7.7 (29.3)	5.8 (22.0)	3.9 (14.7)	1.9 (7.3)

CPM	1/4 in. Fluid Plunger Pumps				3/8 in. Fluid Plunger Pumps			
	GPD (LPD)				GPD (LPD)			
	Full Stroke	3/4 Stroke	1/2 Stroke	1/4 Stroke	Full Stroke	3/4 Stroke	1/2 Stroke	1/4 Stroke
5	1.4 (5.3)	1.1 (4.0)	0.7 (2.7)	0.4 (1.3)	3.2 (12.2)	2.4 (9.2)	1.6 (6.1)	0.8 (3.1)
10	2.8 (10.7)	2.1 (8.0)	1.4 (5.3)	0.7 (2.7)	6.5 (24.5)	4.9 (18.4)	3.2 (12.2)	1.6 (6.1)
15	4.2 (16.0)	3.2 (12.0)	2.1 (8.0)	1.1 (4.0)	9.7 (36.7)	7.3 (27.6)	4.9 (18.4)	2.4 (9.2)
20	5.6 (21.3)	4.2 (16.0)	2.8 (10.7)	1.4 (5.3)	12.9 (49.0)	9.7 (36.7)	6.5 (24.5)	3.2 (12.2)
25	7.0 (26.6)	5.3 (20.0)	3.5 (13.3)	1.8 (6.7)	16.2 (61.2)	12.1 (45.9)	8.1 (30.6)	4.0 (15.3)
30	8.4 (32.0)	6.3 (24.0)	4.2 (16.0)	2.1 (8.0)	19.4 (73.5)	14.6 (55.1)	9.7 (36.7)	4.9 (18.4)
35	9.9 (37.3)	7.4 (28.0)	4.9 (18.6)	2.5 (9.3)	22.7 (85.7)	17.0 (64.3)	11.3 (42.9)	5.7 (21.4)
40	11.3 (42.6)	8.4 (32.0)	5.6 (21.3)	2.8 (10.7)	25.9 (98.0)	19.4 (73.5)	12.9 (49.0)	6.5 (24.5)
45	12.7 (48.0)	9.5 (36.0)	6.3 (24.0)	3.2 (12.0)	29.1 (110.2)	21.8 (82.7)	14.6 (55.1)	7.3 (27.6)
50	14.1 (53.3)	10.6 (40.0)	7.0 (26.6)	3.5 (13.3)	32.4 (122.5)	24.3 (91.9)	16.2 (61.2)	8.1 (30.6)
55	15.5 (58.6)	11.6 (44.0)	7.7 (29.3)	3.9 (14.7)	35.6 (134.7)	26.7 (101.1)	17.8 (67.4)	8.9 (33.7)
60	16.9 (63.9)	12.7 (48.0)	8.4 (32.0)	4.2 (16.0)	38.8 (147.0)	29.1 (110.2)	19.4 (73.5)	9.7 (36.7)

CPM	1/2 in. Fluid Plunger Pumps				5/8 in. Fluid Plunger Pumps			
	GPD (LPD)				GPD (LPD)			
	Full Stroke	3/4 Stroke	1/2 Stroke	1/4 Stroke	Full Stroke	3/4 Stroke	1/2 Stroke	1/4 Stroke
5	4.9 (18.5)	3.7 (13.9)	2.4 (9.3)	1.2 (4.6)	7.6 (29.0)	5.7 (21.7)	3.8 (14.5)	1.9 (7.2)
10	9.8 (37.1)	7.3 (27.8)	4.9 (18.5)	2.4 (9.3)	15.3 (57.9)	11.5 (43.4)	7.6 (29.0)	3.8 (14.5)
15	14.7 (55.6)	11.0 (41.7)	7.3 (27.8)	3.7 (13.9)	22.9 (86.9)	17.2 (65.2)	11.5 (43.4)	5.7 (21.7)
20	19.6 (74.1)	14.7 (55.6)	9.8 (37.1)	4.9 (18.5)	30.6 (115.8)	22.9 (86.9)	15.3 (57.9)	7.6 (29.0)
25	24.5 (92.7)	18.4 (69.5)	12.2 (46.3)	6.1 (23.2)	38.2 (144.8)	28.7 (108.6)	19.1 (72.4)	9.6 (36.2)
30	29.4 (111.2)	22.0 (83.4)	14.7 (55.6)	7.3 (27.8)	45.9 (173.7)	34.4 (130.3)	22.9 (86.9)	11.5 (43.4)
35	34.3 (129.7)	25.7 (97.3)	17.1 (64.9)	8.6 (32.4)	53.5 (202.7)	40.2 (152.0)	26.8 (101.4)	13.4 (50.7)
40	39.2 (148.3)	29.4 (111.2)	19.6 (74.1)	9.8 (37.1)	61.2 (231.7)	45.9 (173.7)	30.6 (115.8)	15.3 (57.9)
45	44.1 (166.8)	33.0 (125.1)	22.0 (83.4)	11.0 (41.7)	68.8 (260.6)	51.6 (195.5)	34.4 (130.3)	17.2 (65.2)
50	49.0 (185.3)	36.7 (139.0)	24.5 (92.7)	12.2 (46.3)	76.5 (289.6)	57.4 (217.2)	38.2 (144.8)	19.1 (72.4)
55	53.9 (203.9)	40.4 (152.9)	26.9 (101.9)	13.5 (51.0)	84.1 (318.5)	63.1 (238.9)	42.1 (159.3)	21.0 (79.6)
60	58.8 (222.4)	44.1 (166.8)	29.4 (111.2)	14.7 (55.6)	91.8 (347.5)	68.8 (260.6)	45.9 (173.7)	22.9 (86.9)

CPM	3/4 in. Fluid Plunger Pumps			
	GPD (LPD)			
	Full Stroke	3/4 Stroke	1/2 Stroke	1/4 Stroke
5	11.7 (44.3)	8.8 (33.2)	5.9 (22.2)	2.9 (11.1)
10	23.4 (88.6)	17.6 (66.5)	11.7 (44.3)	5.9 (22.2)
15	35.1 (132.9)	26.3 (99.7)	17.6 (66.5)	8.8 (33.2)
20	46.8 (177.2)	35.1 (132.9)	23.4 (88.6)	11.7 (44.3)
25	58.5 (221.5)	43.9 (166.1)	29.3 (110.8)	14.6 (55.4)
30	70.2 (265.8)	52.7 (199.4)	35.1 (132.9)	17.6 (66.5)
35	81.9 (310.1)	61.4 (232.6)	41.0 (155.1)	20.5 (77.5)
40	93.6 (354.4)	70.2 (265.8)	46.8 (177.2)	23.4 (88.6)
45	105.3 (398.8)	79.0 (299.1)	52.7 (199.4)	26.3 (99.7)
50	117.0 (443.1)	87.8 (332.3)	58.5 (221.5)	29.3 (110.8)
55	128.7 (487.4)	96.6 (365.5)	64.4 (243.7)	32.2 (121.8)
60	140.5 (531.7)	105.3 (398.8)	70.2 (265.8)	35.1 (132.9)

Maintenance

Preventive Maintenance Schedule

The operating conditions of your particular pump determines how often maintenance is required. Establish a preventive maintenance schedule by recording when and what kind of maintenance is needed, and then determine a regular schedule for checking your pump.

Tighten Threaded Connections

Check that all threaded connections are tight at routine intervals.

Tighten Packings

The packings included in your pump have the ability to be adjusted to stop leaks that develop when the seals are worn. If a leak develops in the pump's fluid section, tighten the packing nut clockwise by 1/16th of a turn, or lower, until the leak is eliminated. The life of the packing can be affected by over-tightening the packings. If the packing nut needs to be tightened repeatedly after short intervals, replace the packing.

Storage

If the pump is going to be stored for long periods, it is recommended that the pump be flushed with a light-weight oil or rust prohibiter to protect pump components. Store the pump with protective fluid inside whenever possible.

Troubleshooting



1. Follow **Pressure Relief Procedure**, page 17, before checking or repairing pump.
2. Check all possible problems and causes before disassembling pump.





Problem	Cause	Solution
Pump runs, but chemical discharges at the incorrect rate.	Inlet check is clogged with debris.	Remove debris from check valve.
	Inlet check o-ring is damaged.	Evaluate o-ring chemical compatibility and replace as required.
		Ensure suction lines are tight, and then prime the pump.
	Packing leak.	Air in pump head.
	Inadequate chemical supply.	Ensure chemical tank is filled.
		Inspect and replace chemical filter.
Incorrect calibration.	Ensure the calibration gauge is functioning properly with good venting.	
Problem	Cause	Solution
Pump does not stroke.	Inadequate pneumatic supply.	If the pressure is too low: increase the pneumatic supply pressure.
		If the volume is too low: ensure the pneumatic supply volume is adequate to operate the pump.
	Dirty gas supply.	Install a filter.
		Replace the filter element.
	Inadequate internal lubrication.	Ensure pneumatic supply gas is clean and dry with a working filter. Then lubricate the air motor internals.
		Add an oiler if pneumatic supply gas contains solvents that are washing out the factory grease. Graco oiler 237212.
	Fluid back pressure is too high.	Verify pump is sized to back pressure. Check inlet gas.
	Timing valve is not cycling.	Clean timing valve.
Rebuild timing valve.		
Packings too tight.	Loosen or replace packing.	

Problem	Cause	Solution
<p>Chemical is leaking from packing.</p>	<p>Worn Packing</p>	<p>Tighten the packing nut. If leak persists then replace the packing.</p> <p>NOTE: the packing nut is set from the factory and doe snot require tightening when initially installed.</p>
		<p>Chemical compatibility.</p> <p>Consult the Graco ONG Chemical Compatibility Guide^a to ensure the seal in use is designed to operate the chemicals being pumped.</p>
		<p>Temperature.</p> <p>Consult the Graco ONG Chemical Compatibility Guide^b to ensure the seal in use is designed to operate in the recommended temperature range.</p>
		<p>Plunger coating.</p> <p>Inspect plunger for coating failure due to chemical or abrasive attack. Replace plunger as required.</p>

a. Find the Graco ONG Chemical Compatibility Guide at www.graco.com.

b. Find the Graco ONG Chemical Compatibility Guide at www.graco.com.

Repair

				
<p>Before servicing or repairing your pump, verify that pressure is relieved according to the Pressure Relief Procedure, page 17, and that all fluid and pneumatic lines are properly shut off, or sealed with compatible valves and disconnected.</p>				

Pump

Disconnect Pump

1. Follow the **Pressure Relief Procedure**, page 17.
2. Expose the packing nut (16) by rotating the dust shield (12) as you pull downward.

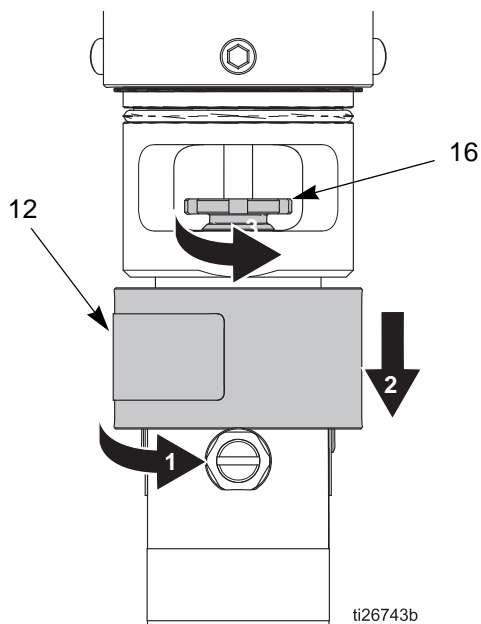

FIG. 6 Expose and loosen packing nut

3. Loosen, but do not remove, the packing nut (16).

4. Remove the fluid cylinder (13) from the middle section. See FIG. 7

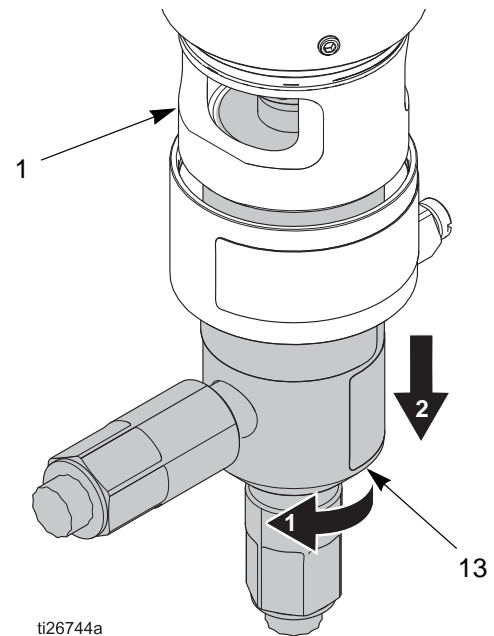

FIG. 7 Remove fluid cylinder

5. Carefully slide the fluid cylinder (13) away from the air motor housing (1), taking great care to keep the fluid plunger (5) from contacting any metal surfaces. The fluid plunger (5) will stay attached to the air motor during repair. See FIG. 7 and FIG. 8.

Pump Repair

1. Remove packing nut (16) from fluid cylinder (13).
2. Carefully remove bearings (14) and packing (15) from the fluid cylinder (13).

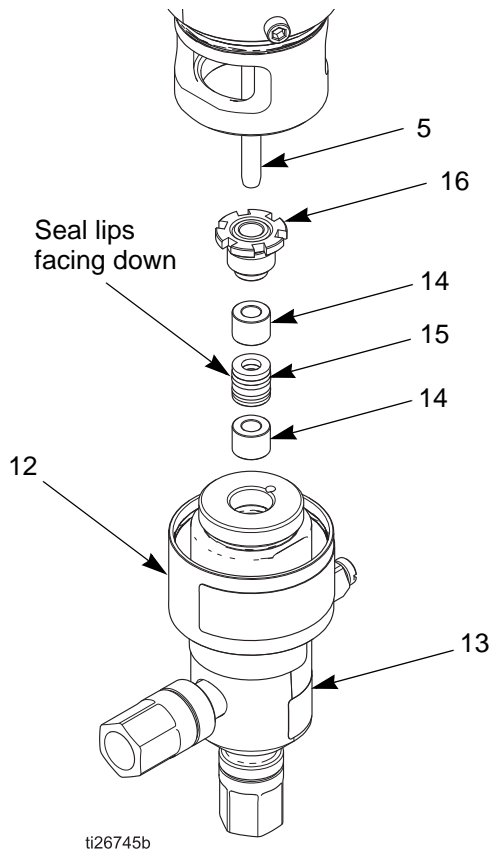

FIG. 8 Remove parts from fluid cylinder

3. Replace packing (15) and bearings (14), if necessary. Lubricate prior to reassembly.

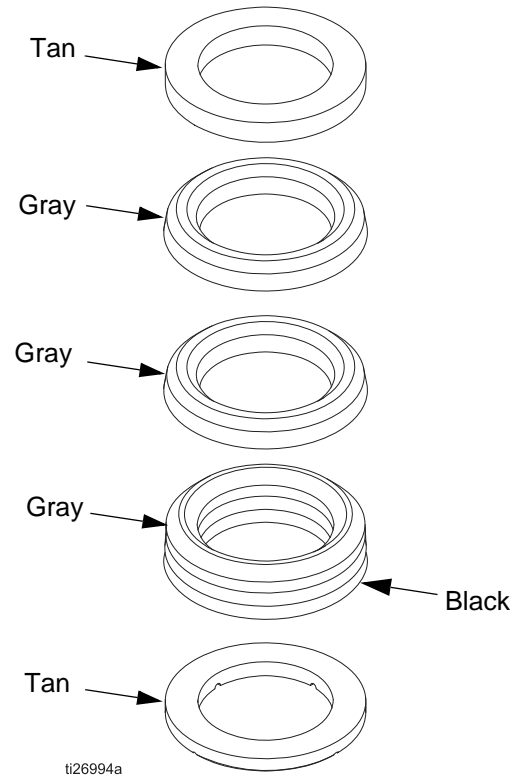

FIG. 9 Packing (15) detailed view

4. Reinsert the packing nut (16), packing (15), and bearings (14) into the fluid cylinder (13). Tighten hand tight and back off ½ of a turn to prevent damage to packing (15) during reassembly.

Reconnect Fluid Cylinder

1. Carefully guide the fluid plunger (5) into the packing nut (16) and through the packing (15) as the threads on the fluid cylinder (13) are brought closer to the air motor housing (1).

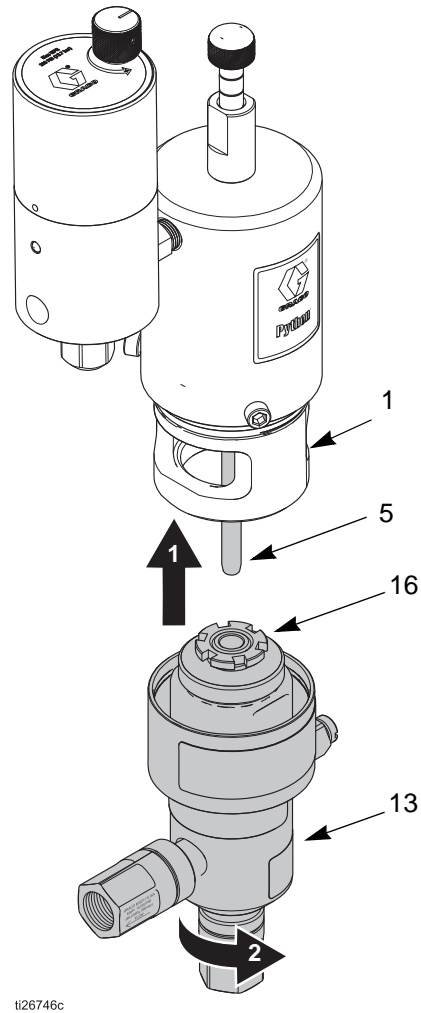

FIG. 10 Reconnect fluid cylinder

2. Tighten fluid cylinder (13) to 30 ft-lbs (40 N•m).

3. Tighten the packing nut (16) to a torque of 15 in-lbs (1.7 N•m), then loosen and tighten again it to a final torque of 5 in-lbs (0.6 N•m).

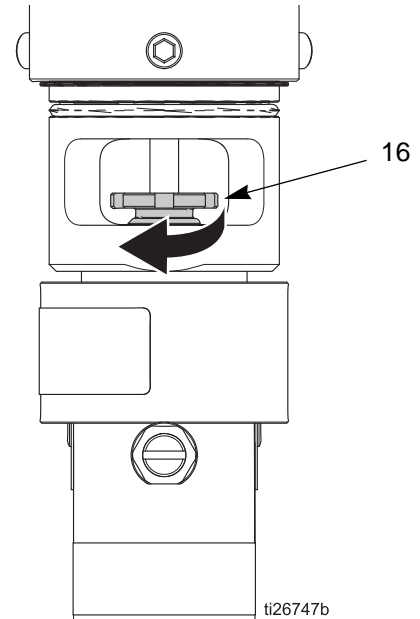

FIG. 11 Tighten packing nut

NOTE: If a torque wrench is not present in the field, an alternative method is to tighten the packing nut (16) finger tight through the window, then use a small punch or hex wrench to further tighten by approximately 10 degrees.

NOTE: If the packing nut (16) is over-tightened, the pump may not complete a full stroke and seal life will be compromised.

Remove Air Piston and Fluid Plunger Assembly

1. Follow the **Pressure Relief Procedure**, page 17.
2. Expose the packing nut (16) by rotating the dust shield (12) as you pull downward.

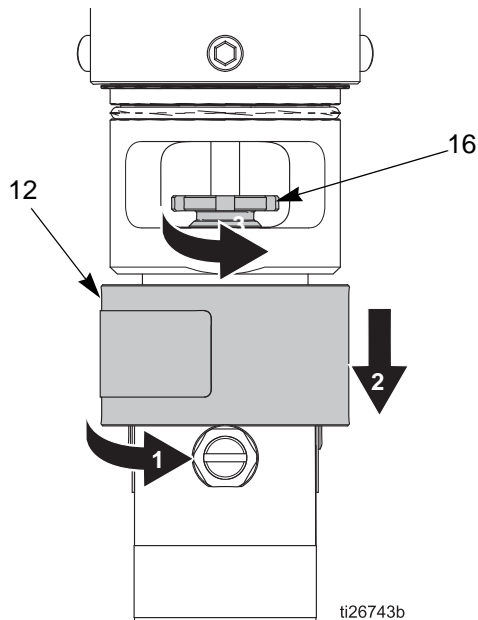
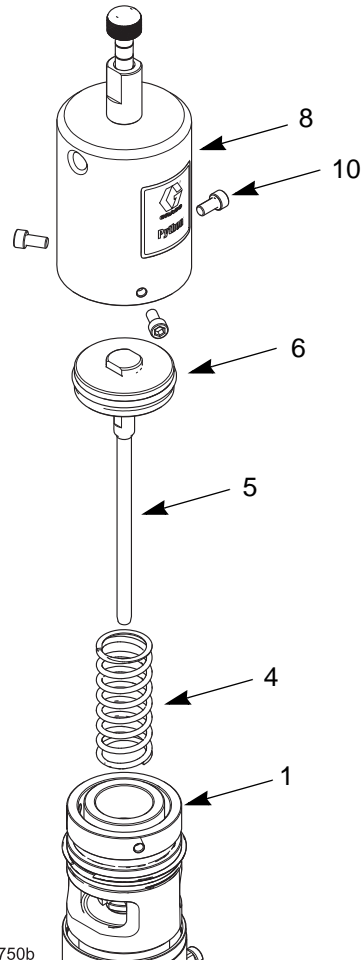

FIG. 12 Expose and loosen packing nut

3. Loosen, but do not remove, the packing nut (16).
4. Remove the air piston cylinder (8) from the air motor housing (1) by loosening the three set screws (10) so they are almost completely removed.



NOTE: The upper air motor is under light spring tension; therefore, it is necessary to hold downward pressure on the air piston cylinder (8) as the set screws (10) are loosened.

FIG. 13 Remove air piston cylinder and components

5. Carefully slide the air piston cylinder (8) away from the air motor housing (1), taking great care to keep the fluid plunger (5) from contacting any metal surfaces. The fluid plunger (5) may come out with the air cylinder (8) during removal and can stay connected to the air piston (6) during repair.
6. Remove the pump piston (6) and plunger (5) assembly from the air cylinder (8).
7. Inspect the air piston seal, fluid plunger surfaces, and return spring (4), and replace as necessary. See **Replace Air Motor Seal** on page 29.

Replace Air Motor Seal

1. Remove the air piston o-ring (7) with a plastic pick from the air piston (6), taking great care not to scratch any of the groove surfaces on the piston.

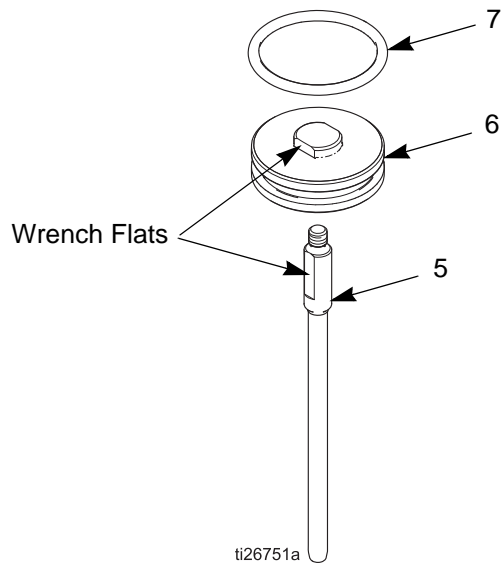

FIG. 14 Air piston and fluid plunger

2. Clean any debris or buildup from the piston (6) and plunger (5) assembly, as well as the air piston cylinder (8) and return spring (4).
3. Apply a liberal amount of assembly grease to the new air piston o-ring (7), and slide it over the piston (6) and into the groove.

Fluid Plunger Replacement

1. Use the wrench flats (see FIG. 14) located on the piston (6) and plunger (5) to loosen and remove the plunger from the piston.
2. Clean the dried thread locker from the internal threads of the piston (6) as much as possible.
3. Apply a thin bead of high strength thread locker to the external threads of the new plunger (5).
4. Install the new plunger and tighten to 75 in-lbs (8.5 N•m).
5. Allow thread locker to dry for 60 minutes before operating the pump.

Air Piston, Fluid Plunger, and Upper Cylinder Reassembly

1. Ensure that all parts are cleaned before reassembly.
2. Apply a thin coat of grease to the inside of the air piston cylinder (8) and piston o-ring (7), and insert the piston (6) and plunger (5) assembly.

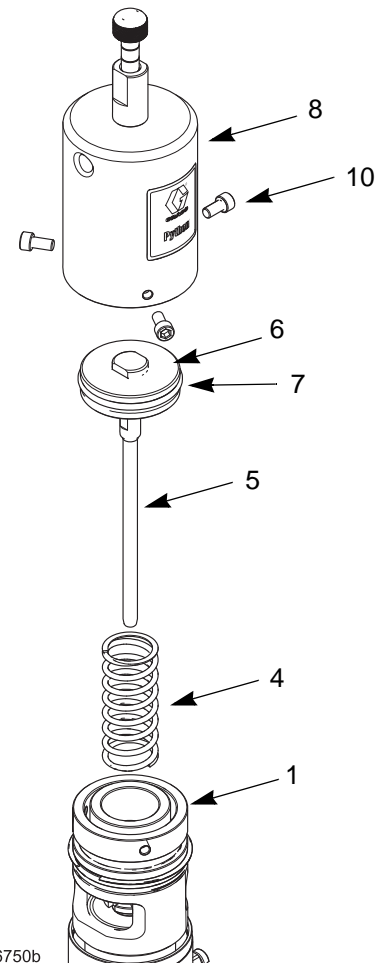

FIG. 15 Reassemble air piston

3. Apply a light coat of assembly grease to the end of the plunger (5), making certain the tip is fully coated.
4. Place the return spring (4) inside the piston stop (2).
5. Reconnect the air piston cylinder (8) to the air motor housing (1). Carefully guide the fluid plunger (5) into the packing nut (16) and through the packing as the air piston cylinder is brought closer to the air motor housing. Light pressure is required to keep the air piston cylinder in place. Ensure the cylinder (8) is

pushed down to the hard stop so that the set screws (10) engage the groove.

6. Reinstall and tighten the three set screws (10) to hold the air piston cylinder (8) in place.
7. Tighten the packing nut (16) to a torque of 15 in-lbs (1.7 N•m), then loosen and tighten again it to a final torque of 5 in-lbs (0.6 N•m).

NOTE: If a torque wrench is not present in the field, an alternative method is to tighten the nut finger tight through the window, then use a small punch or hex wrench to further tighten by approximately 10 degrees.

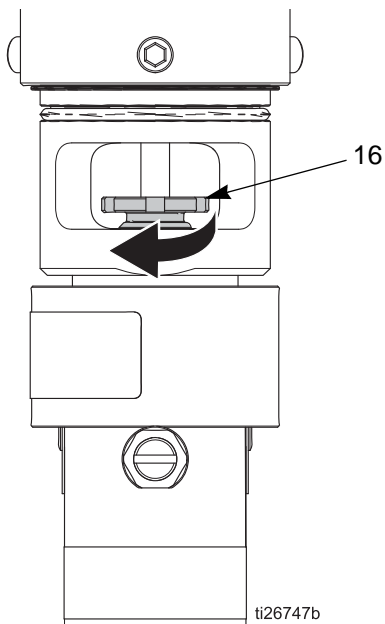

FIG. 16 Tighten packing nut

NOTE: If the packing nut (16) is over-tightened, the pump may not complete a full stroke and seal life will be compromised.

Check Valves



Inlet Check Valve Repair (all models except PCI-xxx-xxH)

1. Follow the **Pressure Relief Procedure**, page 17.
2. Remove the inlet check valve assembly (17).

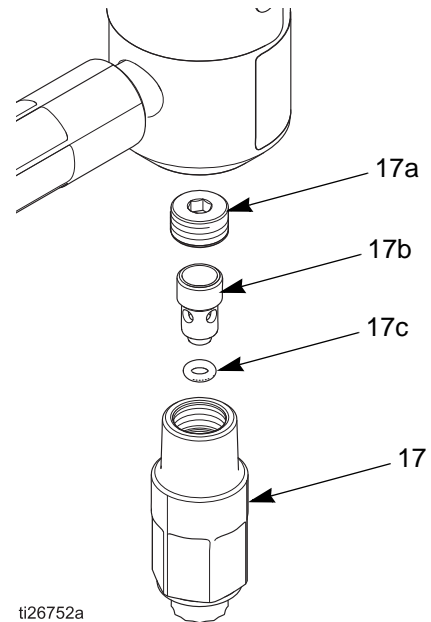

FIG. 17 Inlet check valve assembly

3. Remove the retaining nut (17a) and piston (17b).
4. Remove the piston o-ring (17c).
5. Inspect parts for wear, replace as needed.
6. Install the piston o-ring (17c), piston (17b), and retaining nut (17a).
7. Reconnect the inlet check valve assembly (17).

Inlet Check Valve Repair (models PCI-xxx-xxH only)

1. Follow the **Pressure Relief Procedure**, page 17.
2. Remove the inlet check valve assembly (17).

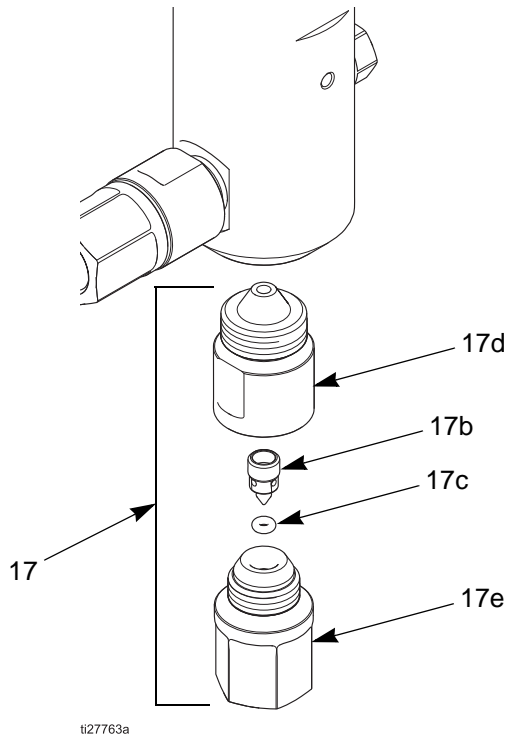

FIG. 18 Inlet check valve assembly

3. Separate the front housing (17d) from the back housing (17e).
4. Remove the piston (17b) and the piston o-ring (17c).
5. Inspect parts for wear, replace as needed.
6. Install the piston o-ring (17c) and piston (17b) in the back housing (17e).
7. Reattach the front housing (17d) to the back housing (17e).
8. Reconnect the inlet check valve assembly (17).

Outlet Check Valve Repair (all models except PCI-xxx-xxH)

1. Follow the **Pressure Relief Procedure**, page 17.
2. Remove the outlet check valve assembly (18).

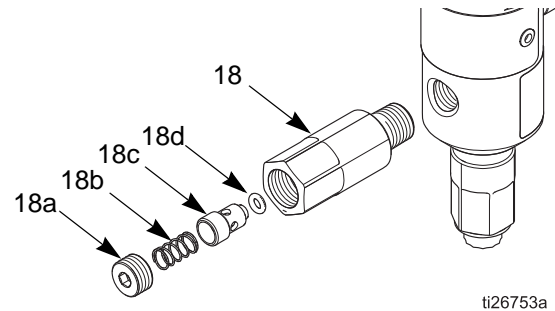

FIG. 19 Outlet check valve assembly

3. Remove the retaining nut (18a), spring (18b), and piston (18c).
4. Remove the piston o-ring (18d).
5. Inspect parts for wear, replace as needed.
6. Install the piston o-ring (18d), piston (18c), spring (18b), and retaining nut (18a).
7. Reconnect the outlet check valve assembly (18).

Outlet Check Valve Repair (models PCI-xxx-xxH only)

1. Follow the **Pressure Relief Procedure**, page 17.
2. Remove the outlet check valve assembly (18).

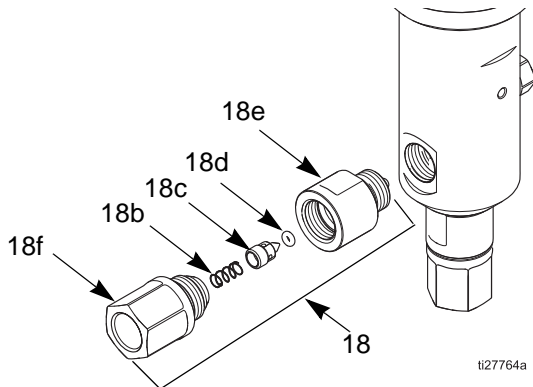

Fig. 20 Outlet check valve assembly

3. Separate the front housing (18e) from the back housing (18f).
4. Remove the spring (18b), piston (18c), and piston o-ring (18d).
5. Inspect parts for wear, replace as needed.
6. Install the piston o-ring (18d), piston (18c), and spring (18b).
7. Reattach the back housing (18f) to the front housing (18e)
8. Reconnect the outlet check valve assembly (18).

Timing Valve



Timing Valve Repair

1. Follow the **Pressure Relief Procedure**, page 17.
2. Remove the spring retainer (112) from the bottom of the timing valve. Inspect the sealing o-ring (114) and replace as necessary.

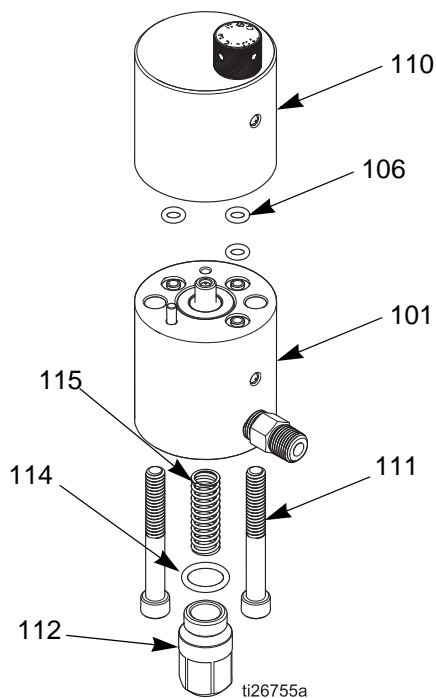

FIG. 21 Separate upper and lower housings

3. Remove the spool return spring (115), inspect and replace if necessary.
4. Remove the two screws (111) to separate the two halves of the timing valve (101 & 110). Inspect the three face seal o-rings (106) and replace as necessary.

5. Pull the spool (103) out of the lower housing (101). Inspect and replace as necessary.

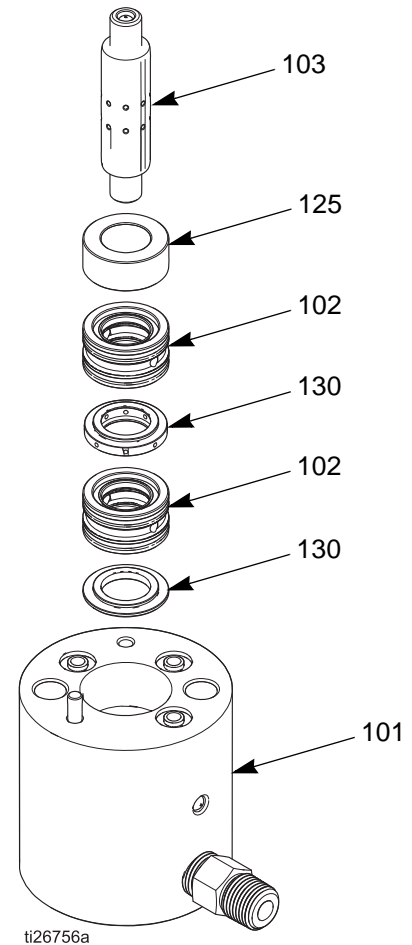

FIG. 22 Remove timing valve spool

6. Remove all of the seal cartridge components by hooking the radial ports with a plastic pick. Take care not to scratch or damage any of the metal or plastic parts. Sealing can be compromised.

- The stack of seal cartridge components includes four sets of seals (105) and o-rings (124). Inspect and replace these as necessary. The repair parts from Graco come as a piston assembly with the seals factory installed.

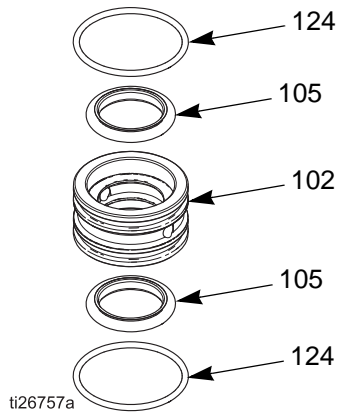

FIG. 23 Seal cartridge

- Remove the drive piston (107) from the upper housing (110) with a needle-nose pliers.

NOTE: Keep the seal (108) and piston (107) together.

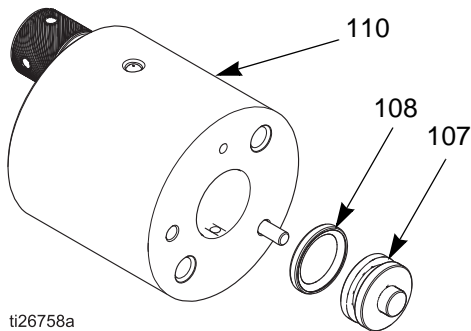

FIG. 24 Remove timing valve piston

- Inspect the seal (108) and piston (107), and replace if necessary. The repair parts from Graco come as a piston assembly with the seals factory installed.

- Remove the control knob (122) by loosening the two hex set screws (123) with a 1/16" hex key wrench.

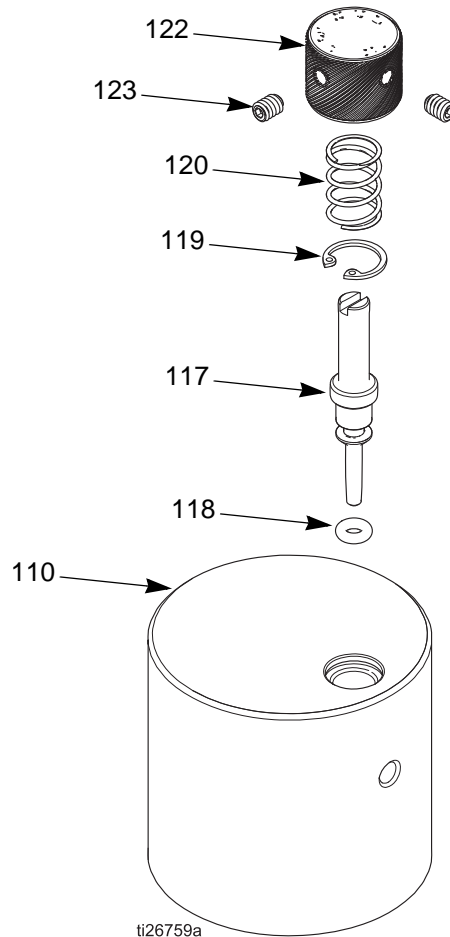

FIG. 25 Remove timing valve knob assembly

- Remove the knob control spring (120) and the retaining ring (119).
- Remove the needle valve (117) by unscrewing it from the housing (110). Inspect the sealing o-ring (118) and replace as necessary.
- Clean and inspect all parts before reassembly.
- Apply a thin coat of grease to the o-ring (118) and reinstall the needle valve (117). Tighten needle finger tight.
- Install the retaining ring (119) and knob control spring (120).

- Place the timing valve knob (122) over the needle valve (117), with the "0" lined up with the marker on the label (121). Tighten the hex set screws (123).

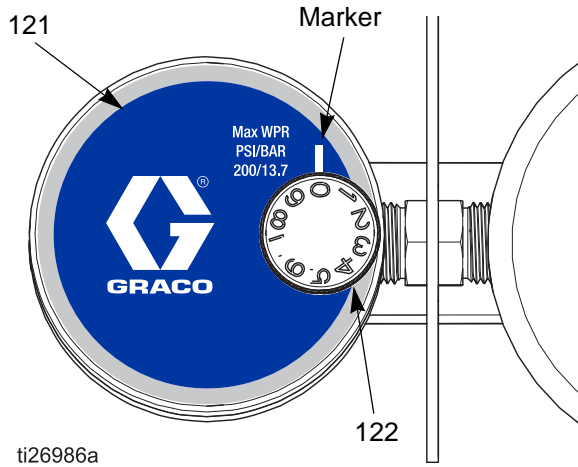

FIG. 26 Align timing valve knob with label

- Reinstall the drive piston (107) in the bottom of the upper housing (110).

NOTE: Do not apply grease to the dynamic seals (105 & 108). They are designed to operate without grease.

- Reinstall the seal cartridges (see FIG. 23 for the order of the seals (105) and o-rings (124)) into the lower housing (101). Apply a thin coat of grease on

the housing lead-in (130) to ease installation and ensure that the seals are not damaged.

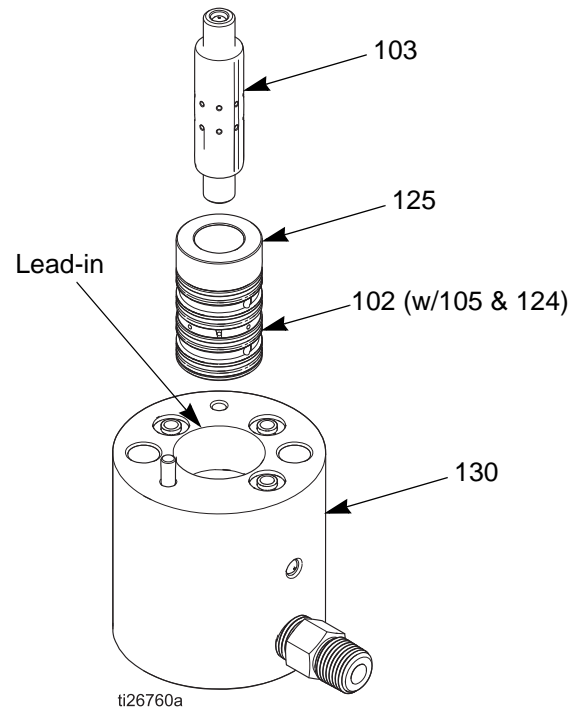

FIG. 27 Reinstall seal cartridges and spool

- Reinstall the spool (103) carefully through the seal cartridge components.

20. Connect the upper and lower housings by lining up the dowel pins (113) in lower housing (101) with the receiving holes in the upper housing (110). Tighten the screws (111).

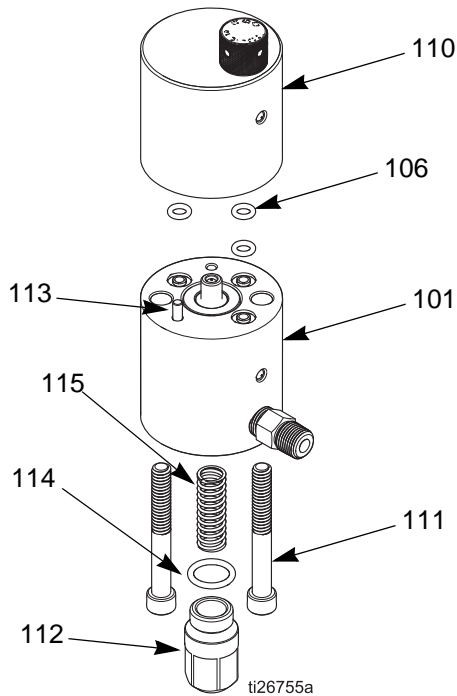
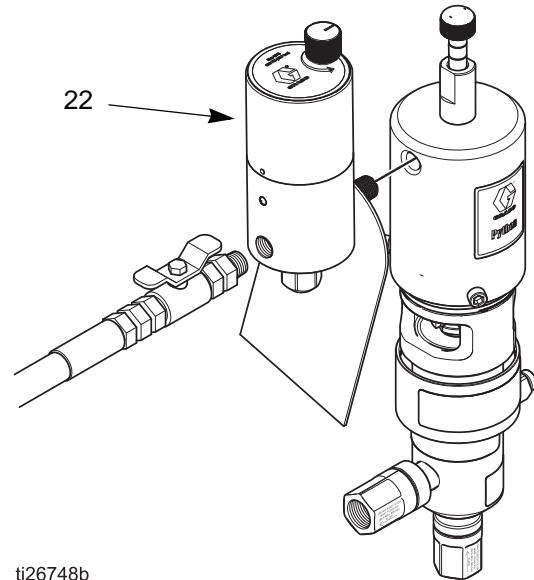

FIG. 28 Reconnect upper and lower housings

21. Insert the spring (115) in the bottom of the lower housing (101) and reinstall the spring retainer (112).

Final Reassembly

1. After all inspections and repairs are completed, reconnect all fluid lines.
2. Reconnect the timing valve (22) onto the pump assembly.



ti26748b

FIG. 29 Reconnect timing valve

3. Reconnect all pneumatic lines.
4. **Prime the Pump**, on page 18.
5. **Calibrate Chemical Dosage**, on page 19, to test for proper pump operation. The calibration test will ensure the desired pump stroke is achieved, as well as, verify proper operation of the check valves.
6. Compare results from calibration test with previous notes or the recommended pump settings in **Stroke Adjustment**, on page 19.

Parts

Python Pneumatic Pump

PCI-200-13S-SA-A shown

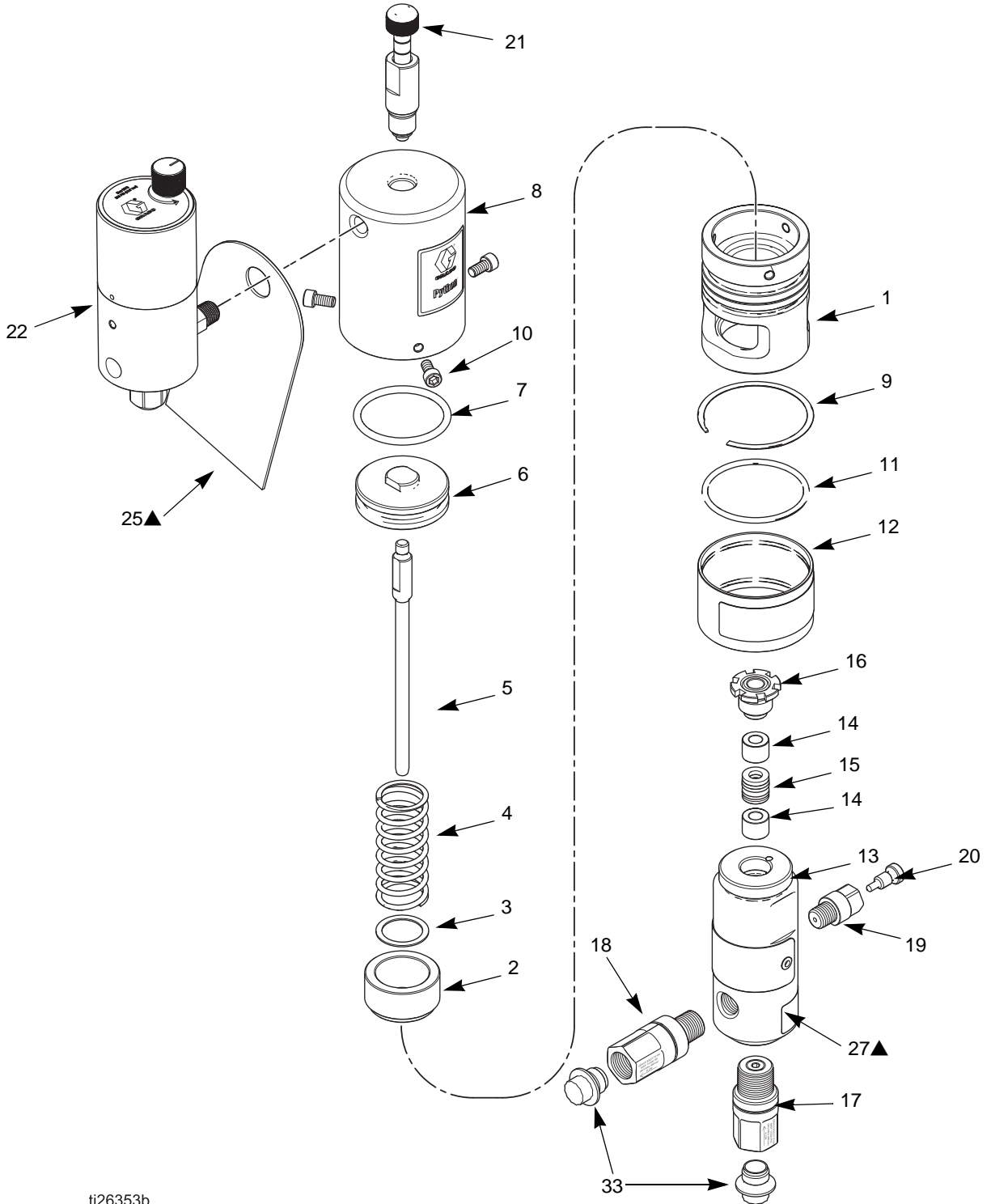

ti26353b

Python Pneumatic Pump Parts List

Ref.	Part	Description	Qty.
1	B32163	Air motor housing, for 1/2" and smaller fluid plungers	1
	B32164	Air motor housing, for 5/8" and larger fluid plungers	1
2	B32165	Air piston stop, for 1.25" air piston	1
	B32166	Air piston stop, for 1.75" and 2.0" air pistons	1
3	--	Fluid plunger wiper, included with fluid plunger spring (ref. 4)	1
4	B32168	Fluid plunger spring	1
5	See Table 1, pg 39	Fluid plunger	1
6	B32172	Air piston, 1.25"	1
	B32173	Air piston, 1.75"	1
	B32174	Air piston, 2.0"	1
7	B32034	O-ring packing, 1.25", included with air piston (ref. 6)	1
	B32035	O-ring packing, 1.75", included with air piston (ref. 6)	1
	B32036	O-ring packing, 2.0", included with air piston (ref. 6)	1
8	B32205	Air piston cylinder, 1.25"	1
	B32206	Air piston cylinder, 1.75"	1
	B32207	Air piston cylinder, 2.00"	1
9	B32163	Retaining ring, included with air motor housing (ref. 1)	1
10	B32175	Set screw, included with air motor housing (ref. 1)	3
11	B32176	O-ring packing, for 1/2" and smaller fluid plungers; included with dust shield (ref. 12)	1
	B32177	O-ring packing, for 5/8" and larger fluid plungers; included with dust shield (ref. 12)	1
12	B32178	Dust shield, for 1/2" and smaller fluid plungers	1
	B32179	Dust shield, for 5/8" and larger fluid plungers	1
13	See Table 2, pg 39	Fluid cylinder	1

Ref.	Part	Description	Qty.
14	See Table 3, pg 39	Plunger bearings, included with packing (ref. 15)	2
15	See Table 3, pg 39	Packing	1
16	See Table 4, pg 39	Packing nut	1
17	See Table 5, pg 40	Inlet valve check	1
18	See Table 6, pg 40	Outlet valve check	1
19	B32191	Priming bleed valve housing, standard pressure (1/4", 3/8", 1/2", 5/8", & 3/4" plungers)	1
	B32250	Priming bleed valve housing, high pressure (1/8" & 3/16" plungers)	1
20*	17F572	Priming bleed valve; included with priming bleed valve housing (ref. 19)	1
21	B32686	Pump stroke adjuster	1
22	B32069	Spool timing valve, see pg 42	1
25▲	17G319	Warning label, hanging	1
27▲	17G320	Warning label, adhesive	1
33	--	Cap plug	2

▲ Replacement Danger and Warning labels, tags, and cards are available at no cost.

* Not included with PCI-xxx-xxH configurations.

Table 1: Fluid Plungers (ref. 5)

Ref	Part Numbers by Fluid Plunger Size Diameter							Qty.
	1/8 in.	3/16 in.	1/4 in.	3/8 in.	1/2 in.	5/8 in.	3/4 in.	
17-4 Stainless Steel Fluid Plungers								
5	B32066	B32067	B32068	B32135	B32136	B32137	B32138	1
Chromex-Coated Fluid Plungers								
5	B32139	B32140	B32141	B32142	B32143	B32144	B32145	1
Ceramic-Coated Fluid Plungers								
5	B32241	B32242	B32243	B32244	B32245	B32246	B32247	1

Table 2: Fluid Cylinders (ref. 16)

Ref	Part Numbers by Fluid Plunger Size Diameter							Qty.
	1/8 in.	3/16 in.	1/4 in.	3/8 in.	1/2 in.	5/8 in.	3/4 in.	
13	B32180	B32181	B32182	B32183	B32184	B32185	B32180	1

Table 3: Packing Stacks (ref. 15), including Plunger Bearings (ref. 14)

Ref	Part Numbers by Fluid Plunger Size Diameter							Qty.
	1/8 in.	3/16 in.	1/4 in.	3/8 in.	1/2 in.	5/8 in.	3/4 in.	
FKM								
15	B32115	B32119	B32094	B32098	B32102	B32123	B32127	1
FKMETP								
15	B32116	B32120	B32095	B32099	B32103	B32124	B32128	1
HNBR								
15	B32117	B32121	B32096	B32100	B32104	B32125	B32129	1
FFKM								
15	B32118	B32122	B32097	B32101	B32105	B32126	B32130	1
AFLAS								
15	B32033	B32041	B32042	B32043	B32044	B32085	B32086	1

Table 4: Packing Nuts (ref. 16)

Ref	Part Numbers by Fluid Plunger Size Diameter							Qty.
	1/8 in.	3/16 in.	1/4 in.	3/8 in.	1/2 in.	5/8 in.	3/4 in.	
16	B32187	B32187	B32187	B32188	B32203	B32190	B32190	1

Table 5: Inlet Valve Check (ref. 17)

Ref	Part Numbers by Fluid Plunger Size Diameter							Qty.
	1/8 in.	3/16 in.	1/4 in.	3/8 in.	1/2 in.	5/8 in.	3/4 in.	
FKM								
17	B32226	B32226	B32216	B32024	B32024	B32024	B32024	1
FKMETP								
17	B32228	B32228	B32218	B32026	B32026	B32026	B32026	1
HNBR								
17	B32230	B32230	B32220	B32113	B32113	B32113	B32113	1
FFKM								
17	B32232	B32232	B32222	B32028	B32028	B32028	B32028	1

Table 6: Outlet Valve Check (ref. 18)

Ref	Part Numbers by Fluid Plunger Size Diameter							Qty.
	1/8 in.	3/16 in.	1/4 in.	3/8 in.	1/2 in.	5/8 in.	3/4 in.	
FKM								
18	B32227	B32227	B32217	B32025	B32025	B32025	B32025	1
FKMETP								
18	B32229	B32229	B32219	B32027	B32027	B32027	B32027	1
HNBR								
18	B32231	B32231	B32221	B32114	B32114	B32114	B32114	1
FFKM								
18	B32233	B32233	B32223	B32029	B32029	B32029	B32029	1

Python Timing Valve Assembly

B32069

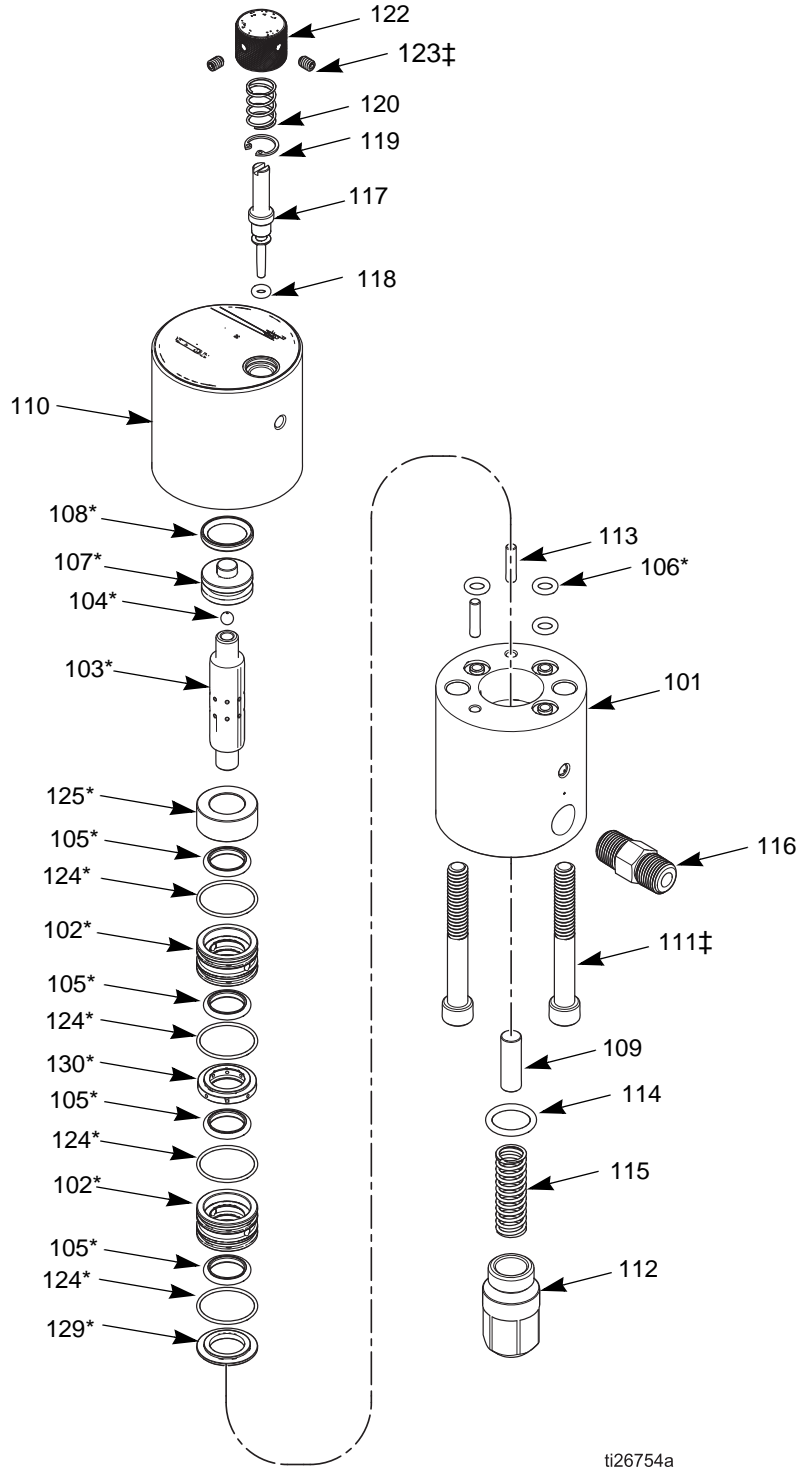

Timing Valve Assembly (B32069) Parts List

Ref.	Part	Description	Qty.
101	B32193	Lower Housing	1
102*	--	Seal Cartridge	2
103*	--	Spool	1
104*	--	Ball, 316 stainless steel; included with lower and upper housing (ref. 101 & 110)	1
105*	--	Seal, Spool	4
106*	--	O-ring; included with lower housing (ref. 101)	3
107*	--	Piston	1
108*	--	Seal, Piston	1
109	--	Pin; included with spring retainer (ref. 112)	1
110	B32194	Upper Housing	1
111‡	--	Screw, 316 SST, 1/4-20	2
112	B32196	Spring Retainer	1
113	--	Dowel Pin; included with lower housing (ref. 101)	2
114	--	O-ring; included with spring retainer (ref. 112)	1
115	B32197	Spool Return Spring	1
116	--	Nipple Fitting, 1/8 NPT; included with lower housing (ref. 101)	1
117	B32199	Timing Valve Needle	1
118	--	O-ring; included with timing valve needle (ref. 117)	1

Ref.	Part	Description	Qty.
119	--	Internal Ring, Stainless Steel; included with timing valve needle (ref. 117)	1
120	--	Knob Spring; included with timing valve needle (ref. 117)	1
122	--	Needle Knob; included with timing valve needle (ref. 117)	1
123‡	--	Set Screw; included with timing valve needle (ref. 117)	2
124*	--	O-ring	4
125*	--	Seal Cartridge Retainer	1
126	--	Grease Lubricant (not shown)	
127	--	Pipe Sealant (not shown)	
129*	--	Bottom Seal Retainer	1
130*	--	Cartridge Spacer	1

* Parts included in Kit B32153 (purchase separately).

‡ Parts included in Kit B32195 (purchase separately).

Kits and Accessories

Additional Kits & Accessories

Part No.	Description
B32045	225-750 PSI Pressure Relief Valve Kit (Adjustable)
B32046	750-1500 PSI Pressure Relief Valve Kit (Adjustable)
B32047	1500-2250 PSI Pressure Relief Valve Kit (Adjustable)
B32048	2250-3000 PSI Pressure Relief Valve Kit (Adjustable)
B32049	3000-4000 PSI Pressure Relief Valve Kit (Adjustable)
B32050	4000-5000 PSI Pressure Relief Valve Kit (Adjustable)
B32051	5000-6000 PSI Pressure Relief Valve Kit (Adjustable)
B32088	SST Calibration Column Kit
B32089	SST Manifold Assembly Kit
B32157	316 SST Ball Valve Kit, 3/4" NPT(F)
B32158	Fluid Filter 6000 PSI
B32159	Fluid Filter 10000 PSI
B32160	Float Switch
B32162	1/4" NPT(F) X 1/4" NPT(F) Check Kit
B32038	FKM Large (3/8" - 3/4") Inlet and Outlet Check Valve Repair Kit (includes a spring and piston o-rings)
B32039	FKM ETP Large (3/8" - 3/4") Inlet and Outlet Check Valve Repair Kit (includes a spring and piston o-rings)
B32040	FFKM Large (3/8" - 3/4") Inlet and Outlet Check Valve Repair Kit (includes a spring and piston o-rings)
B32111	HNBR Large (3/8" - 3/4") Inlet and Outlet Check Valve Repair Kit (includes a spring and piston o-rings)
B32870	TFE/P Large (3/8" - 3/4") Inlet and Outlet Check Valve Repair Kit (includes a spring and piston o-rings)
B32224	FKM Small (1/8" - 1/4") Inlet and Outlet Check Valve Repair Kit (includes a spring and piston o-rings)

B32225	FKM ETP Small (1/8" - 1/4") Inlet and Outlet Check Valve Repair Kit (includes a spring and piston o-rings)
B32235	FFKM Small (1/8" - 1/4") Inlet and Outlet Check Valve Repair Kit (includes a spring and piston o-rings)
B32234	HNBR Small (1/8" - 1/4") Inlet and Outlet Check Valve Repair Kit (includes a spring and piston o-rings)
B32871	TFE/P Small (1/4") Inlet and Outlet Check Valve Repair Kit (includes a spring and piston o-rings)
B32240	HF4 to 1/4" NPT(F) Adapter; 10,000 psi (1/8" - 3/16" plungers)
B32686	Stroke Adjuster Kit

Dimensions

Python Pump Dimensions

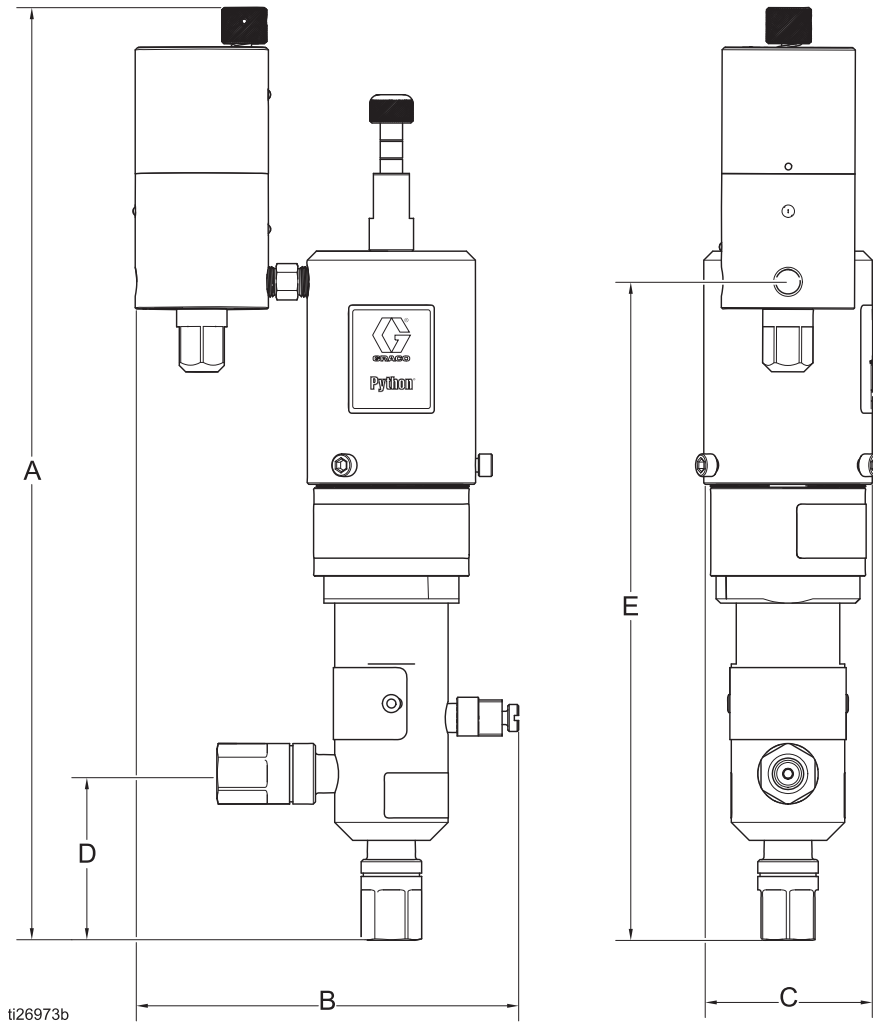

FIG. 30 Python Pump Dimensions

A	B	C	D	E
13.26 in. (33.7 cm)	5.3 in. (13.5 cm)	2.34 in. (5.9 cm)	2.3 in. (5.8 cm)	9.125 in. (23.2 cm)

Performance Charts

1 1/4" Air Motors (PCI-125)

1/8" Plunger (PCI-125-13)

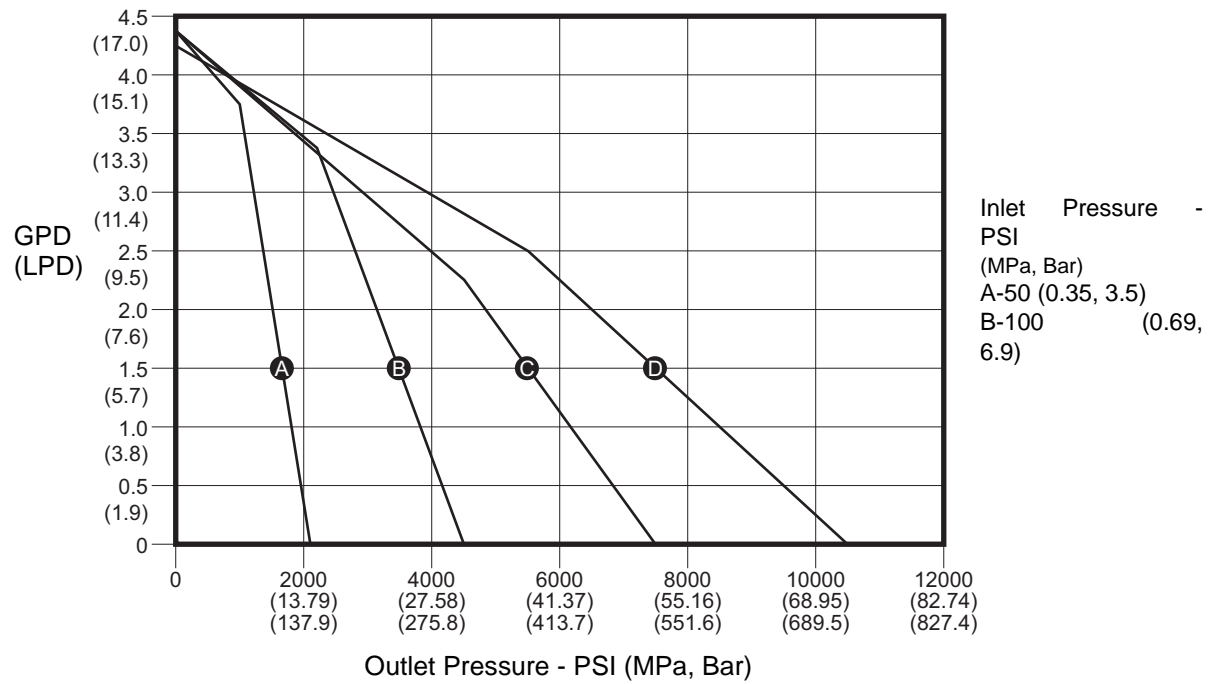

FIG. 31

3/16" Plunger (PCI-125-19)

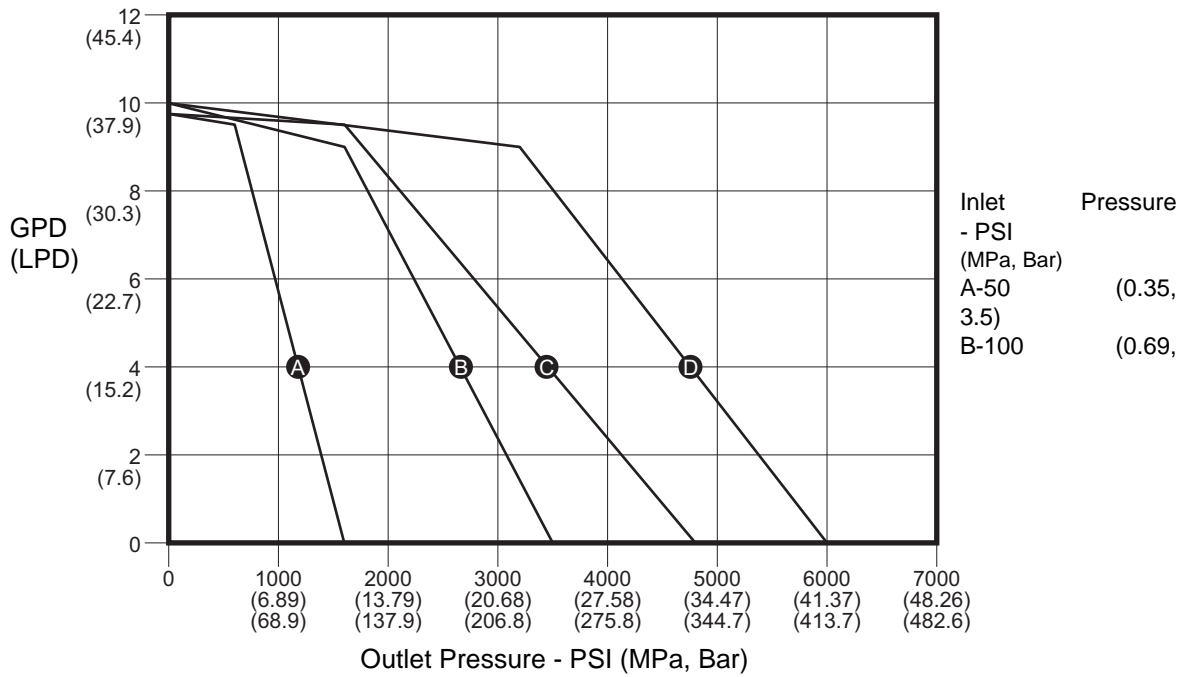

FIG. 32

1/4" Plunger (PCI-125-25)

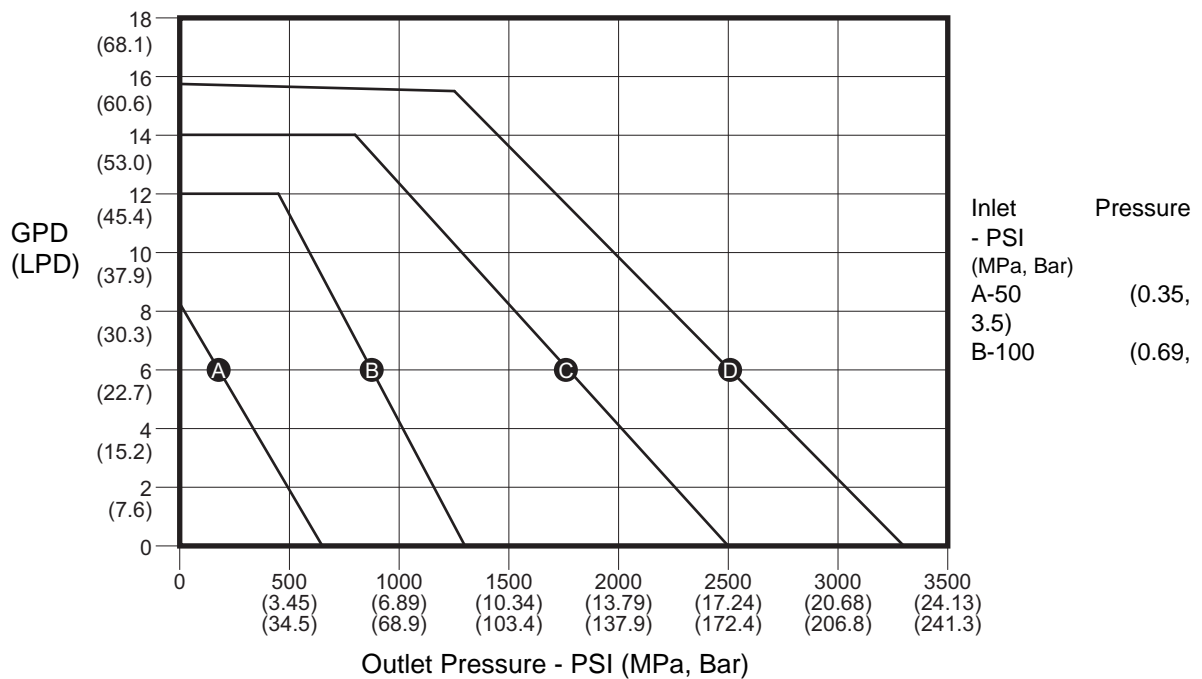

FIG. 33

3/8" Plunger (PCI-125-38)

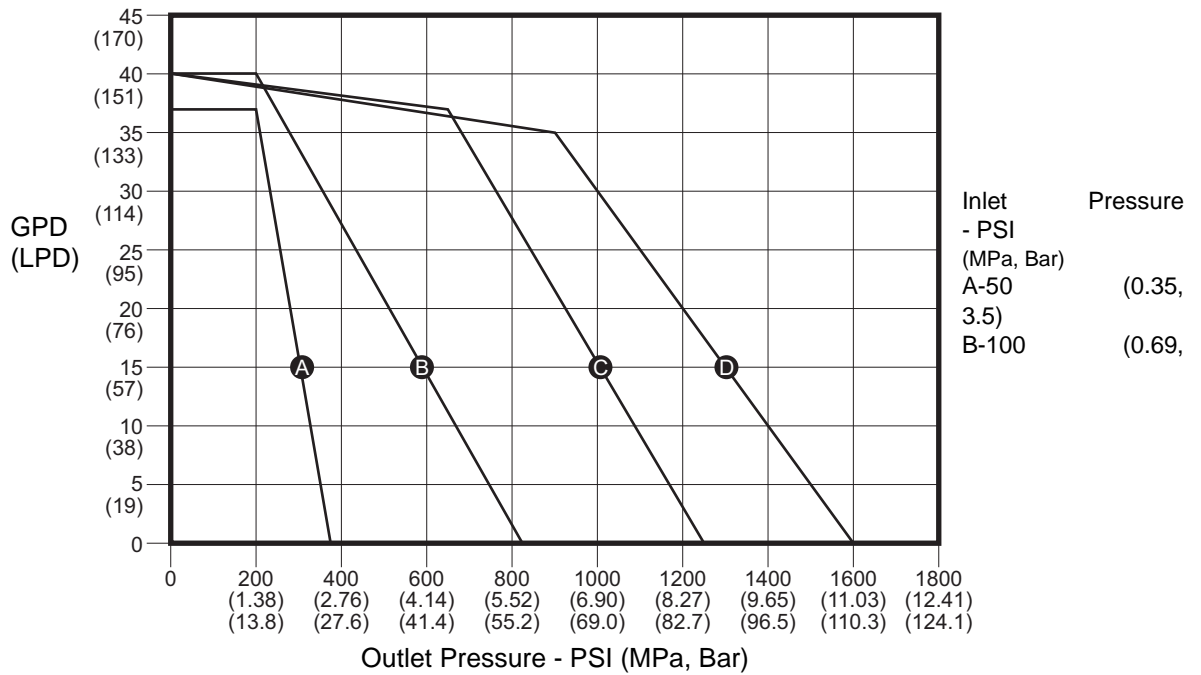

FIG. 34

1/2" Plunger (PCI-125-50)

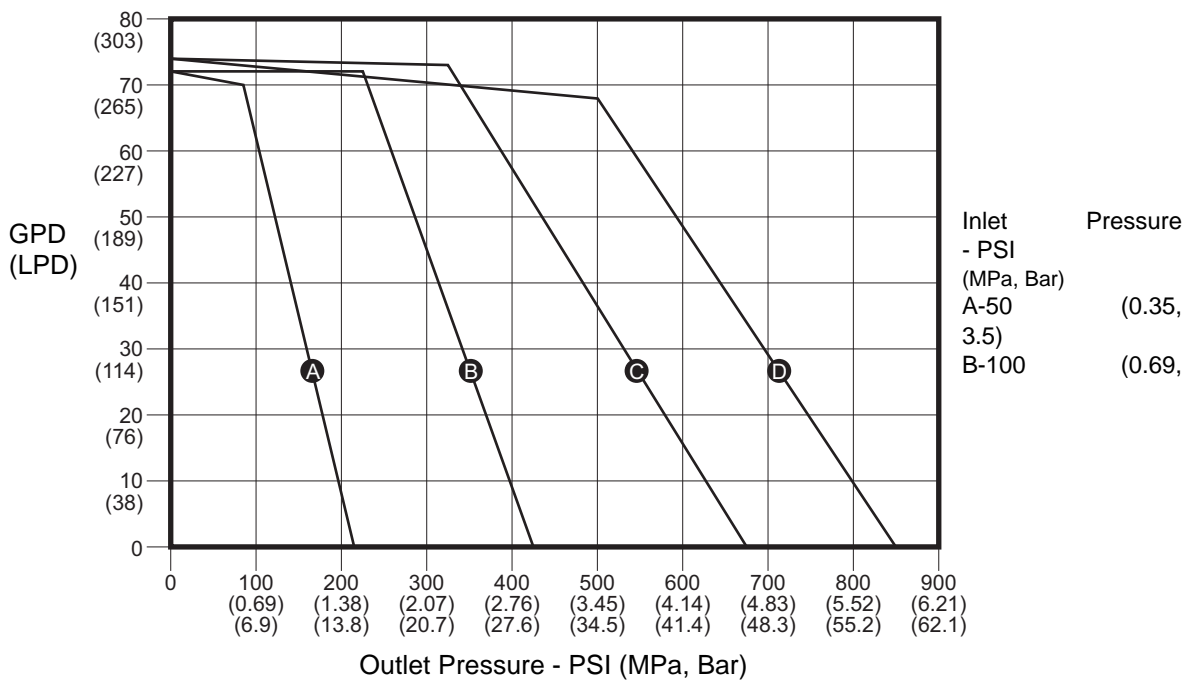

FIG. 35

5/8" Plunger (PCI-125-63)

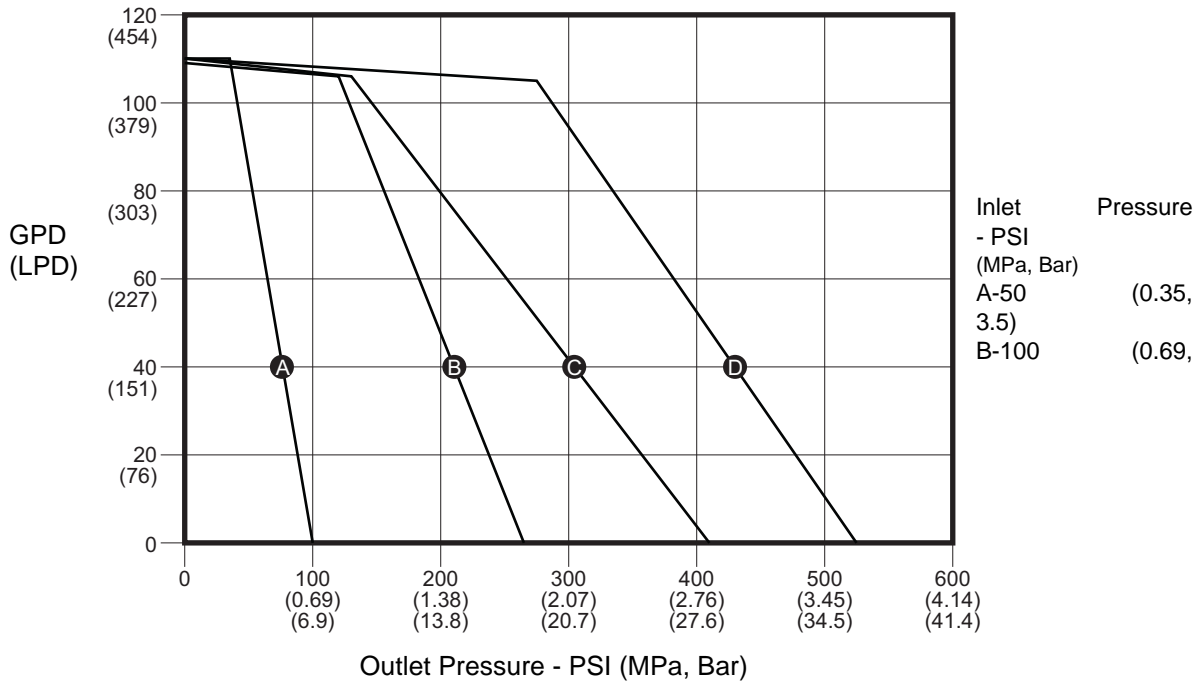

FIG. 36

3/4" Plunger (PCI-125-75)

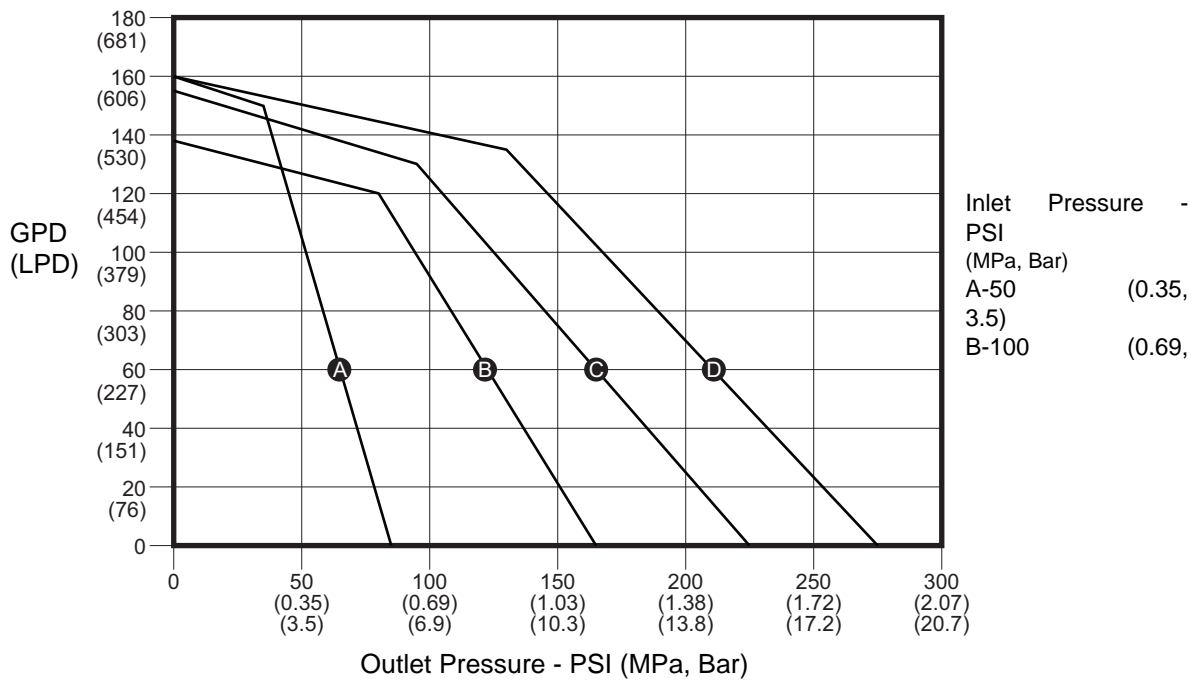

FIG. 37

1 3/4" Air Motors (PCI-175)

1/8" Plunger (PCI-175-13)

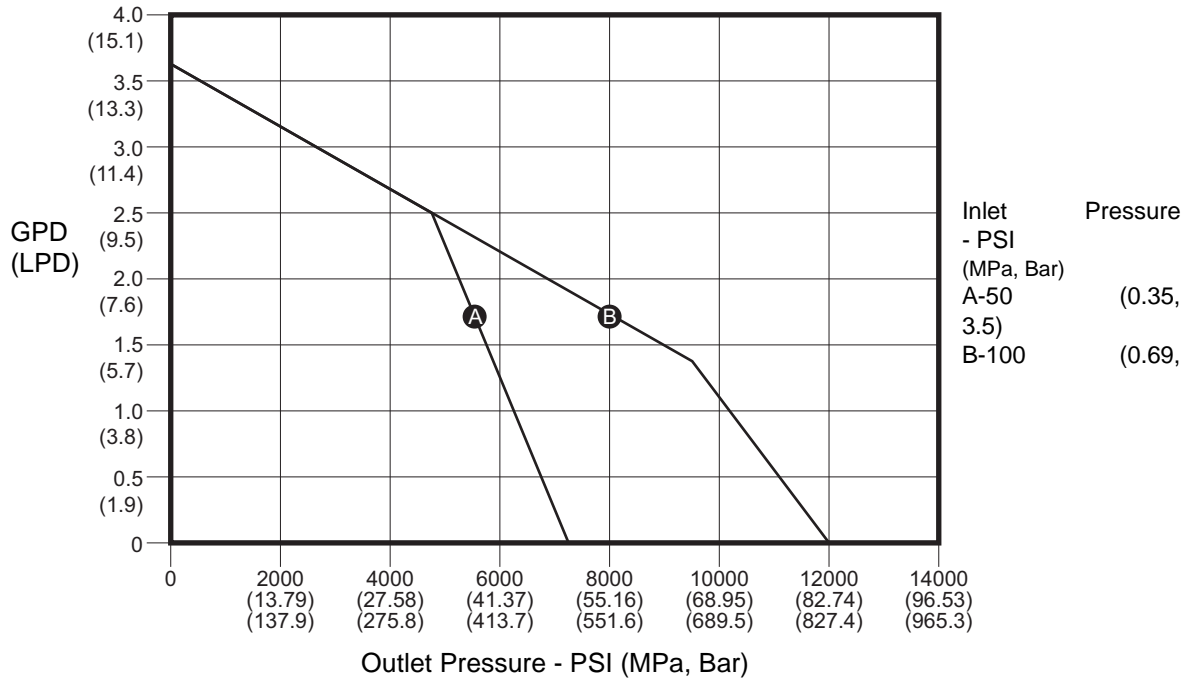

FIG. 38

3/16" Plunger (PCI-175-19)

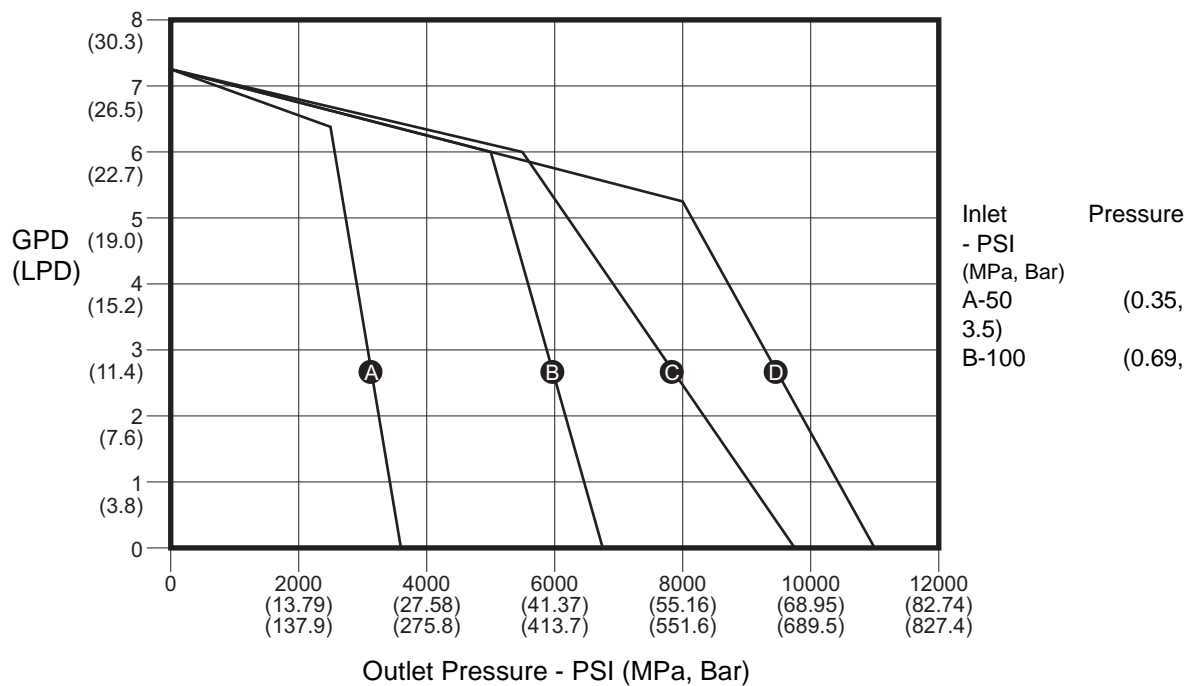

FIG. 39

1/4" Plunger (PCI-175-25)

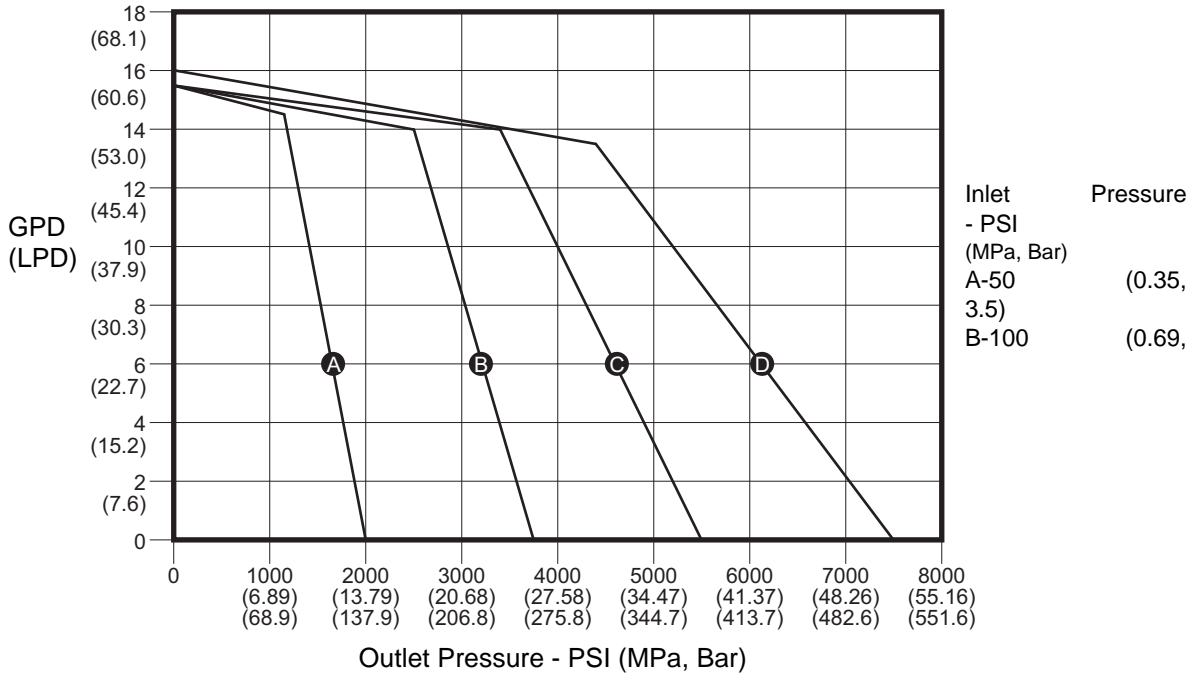

FIG. 40

3/8" Plunger (PCI-175-38)

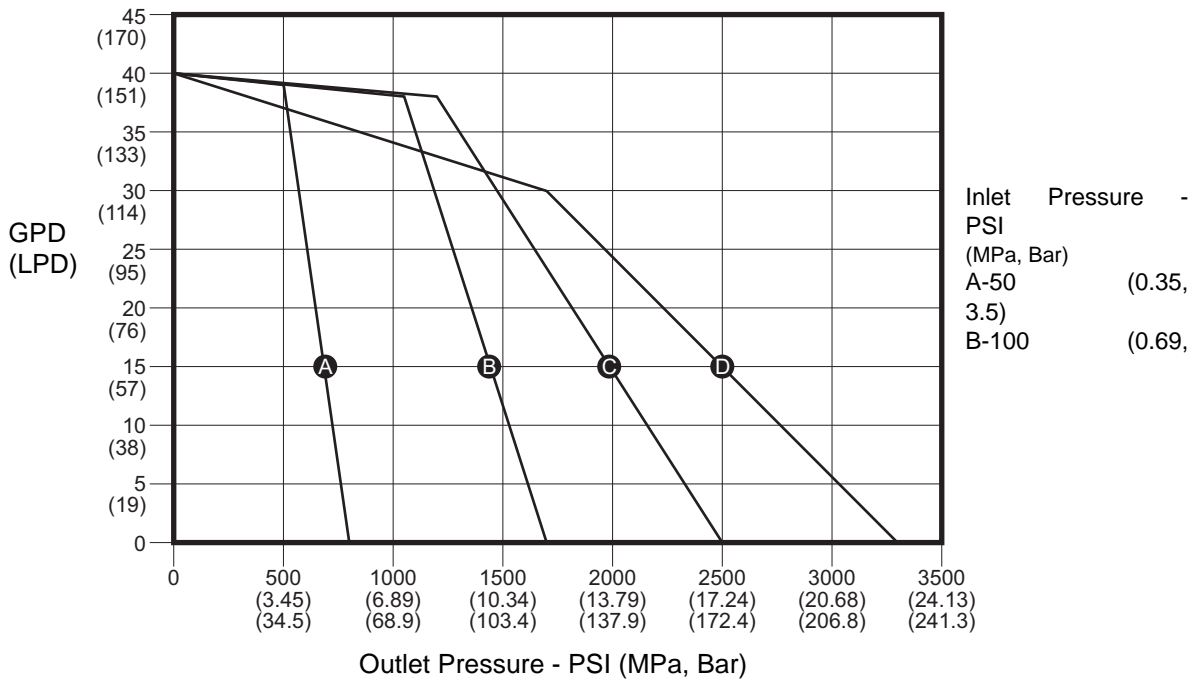

FIG. 41

1/2" Plunger (PCI-175-50)

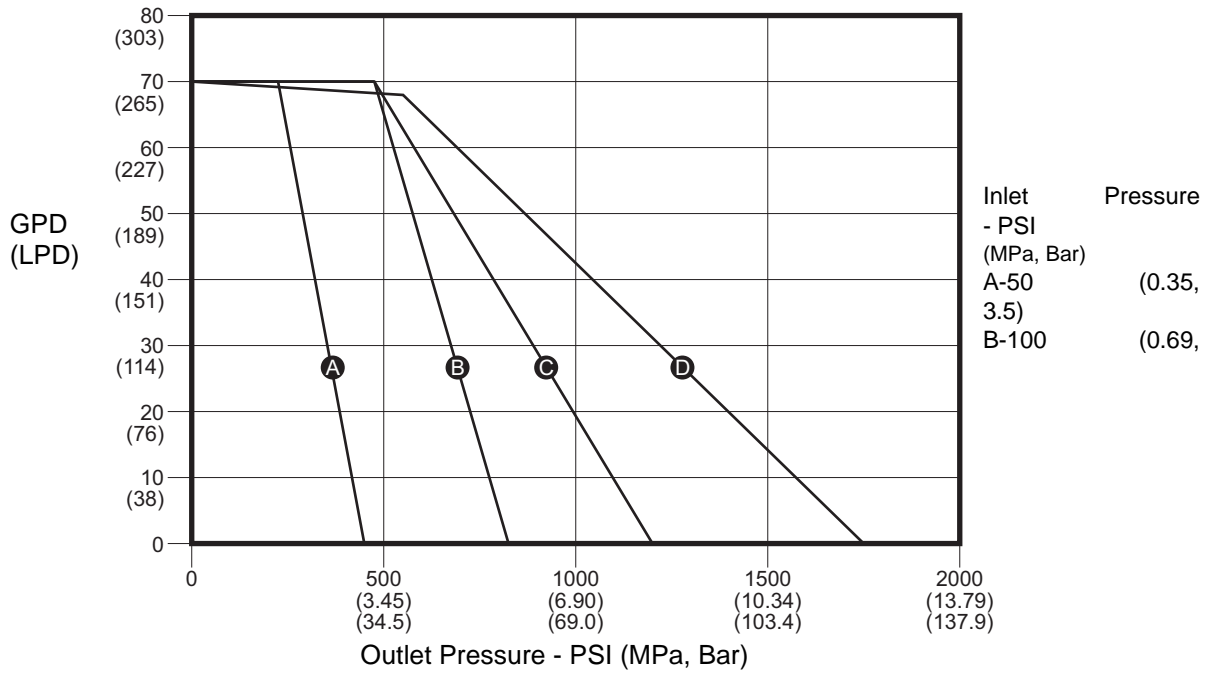

FIG. 42

5/8" Plunger (PCI-175-63)

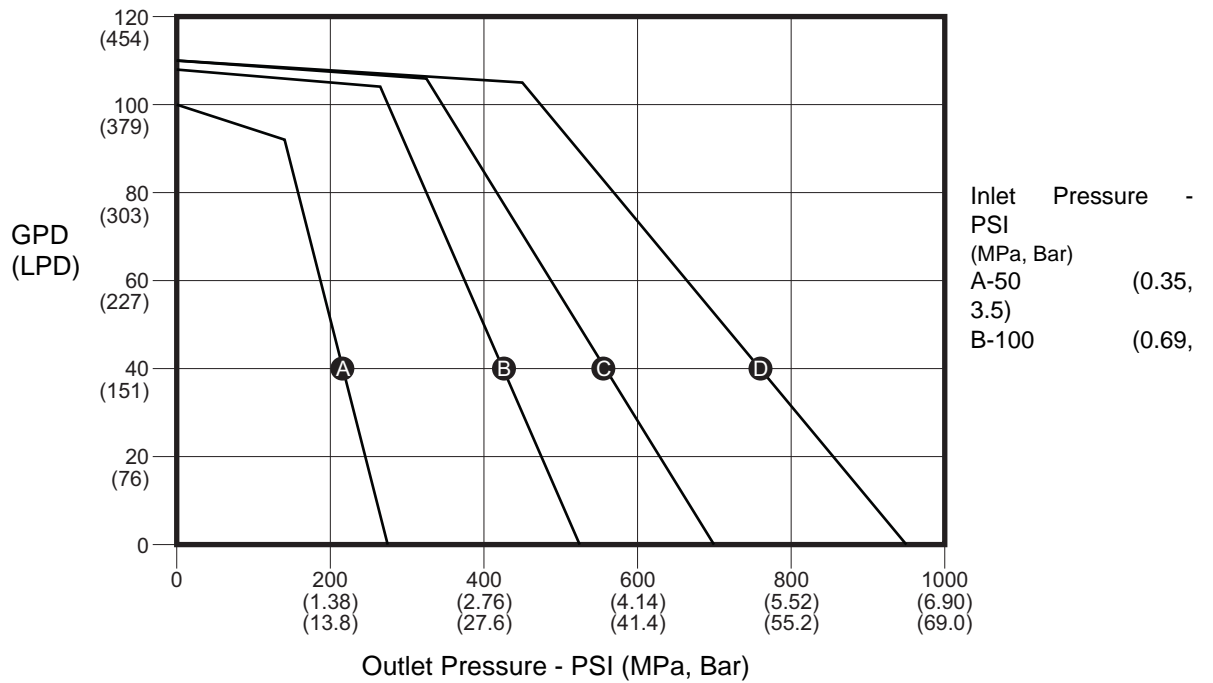

FIG. 43

3/4" Plunger (PCI-175-75)

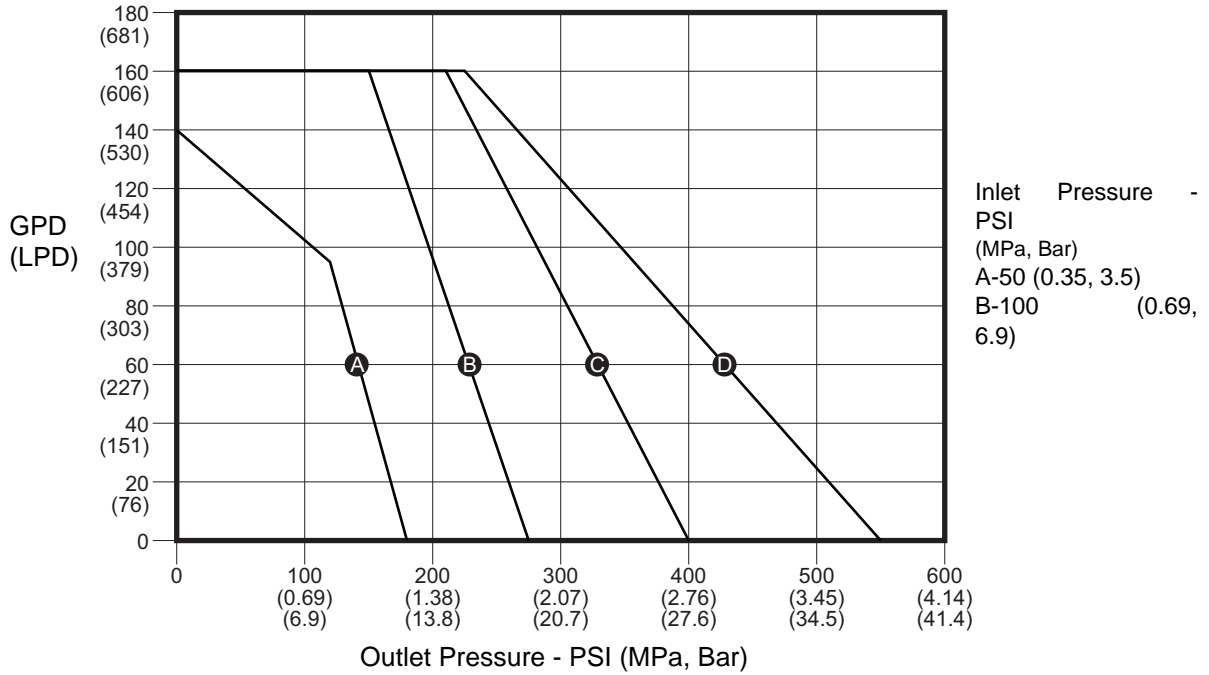

FIG. 44

2" Air Motors (PCI-200)

1/8" Plunger (PCI-200-13)

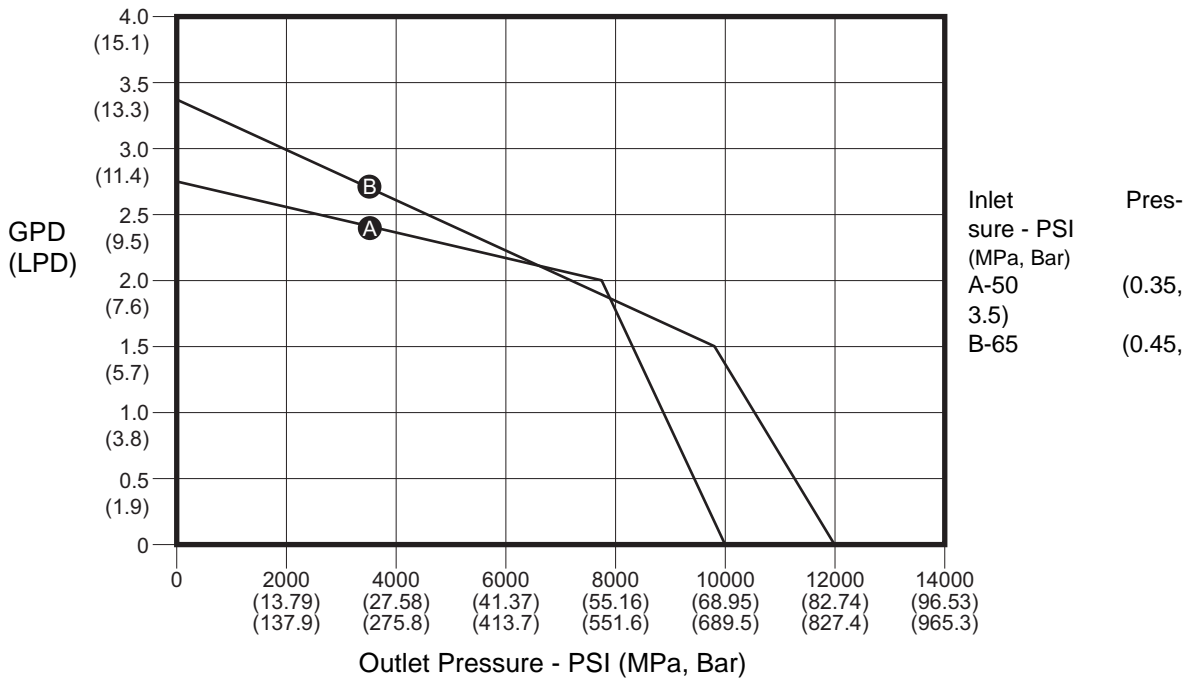

FIG. 45

3/16" Plunger (PCI-200-19)

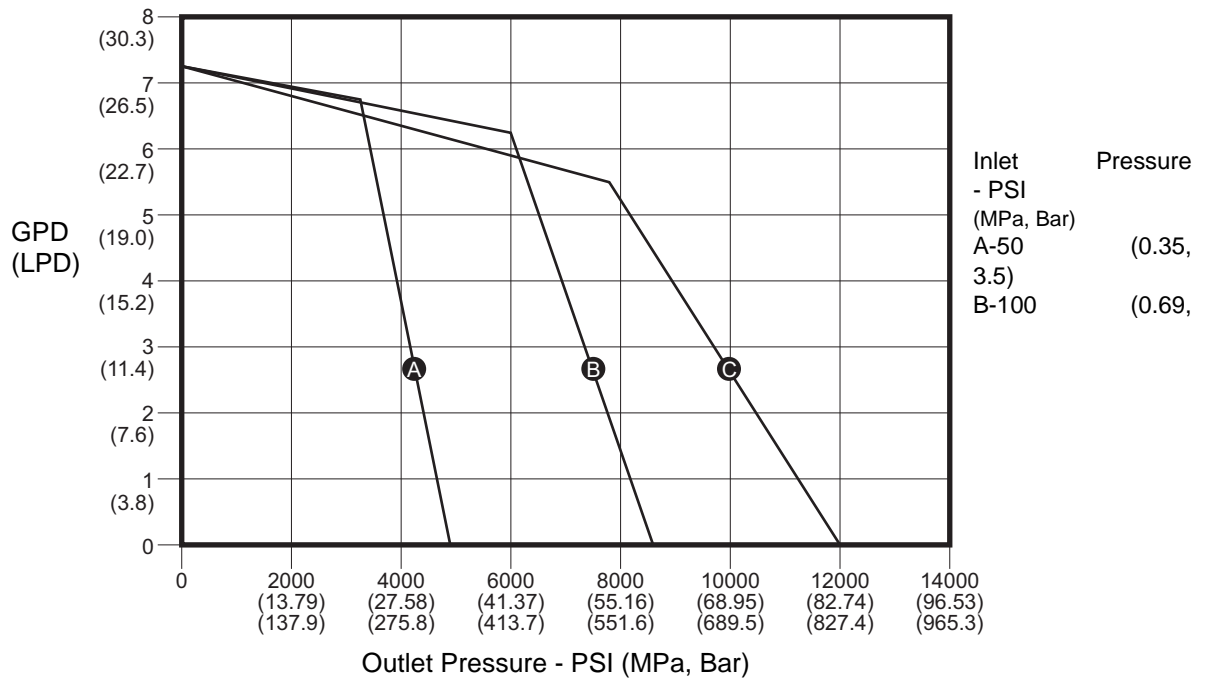

FIG. 46

1/4" Plunger (PCI-200-25)

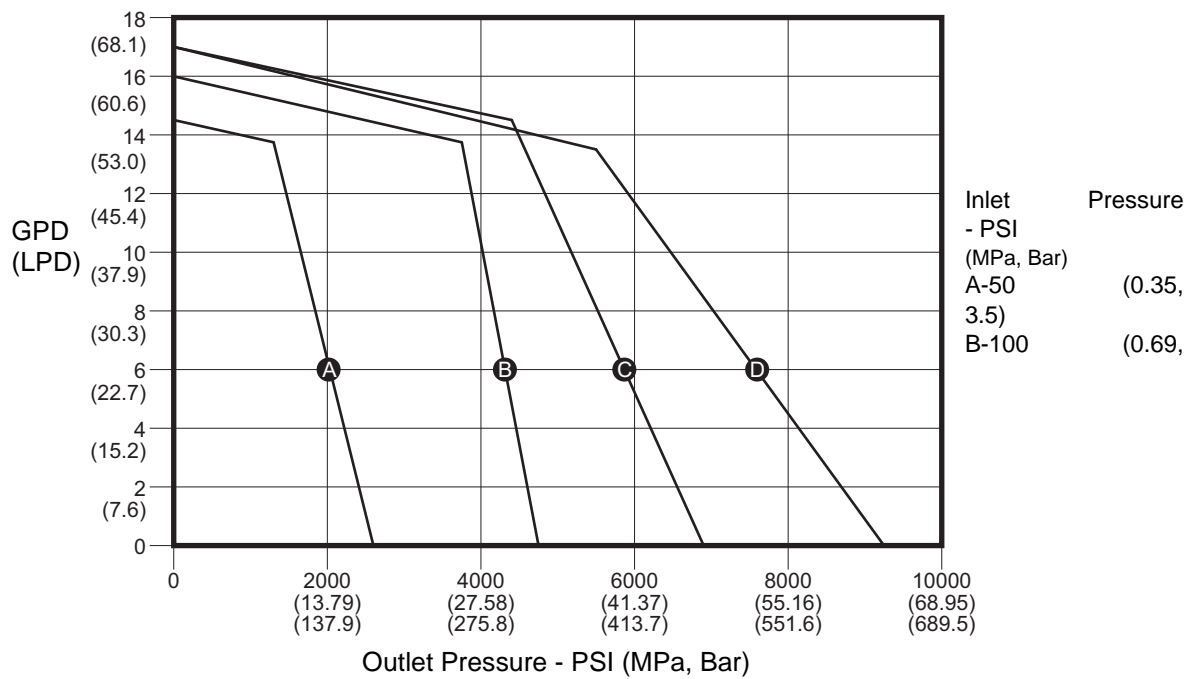

FIG. 47

3/8" Plunger (PCI-200-38)

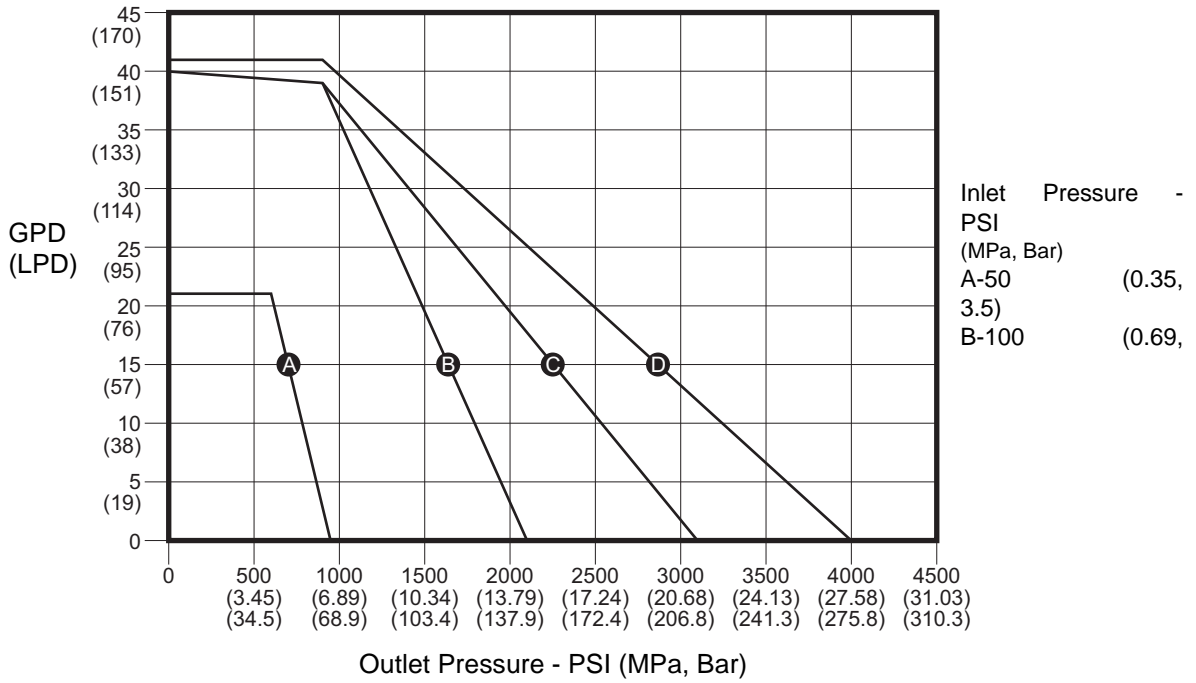

FIG. 48

1/2" Plunger (PCI-200-50)

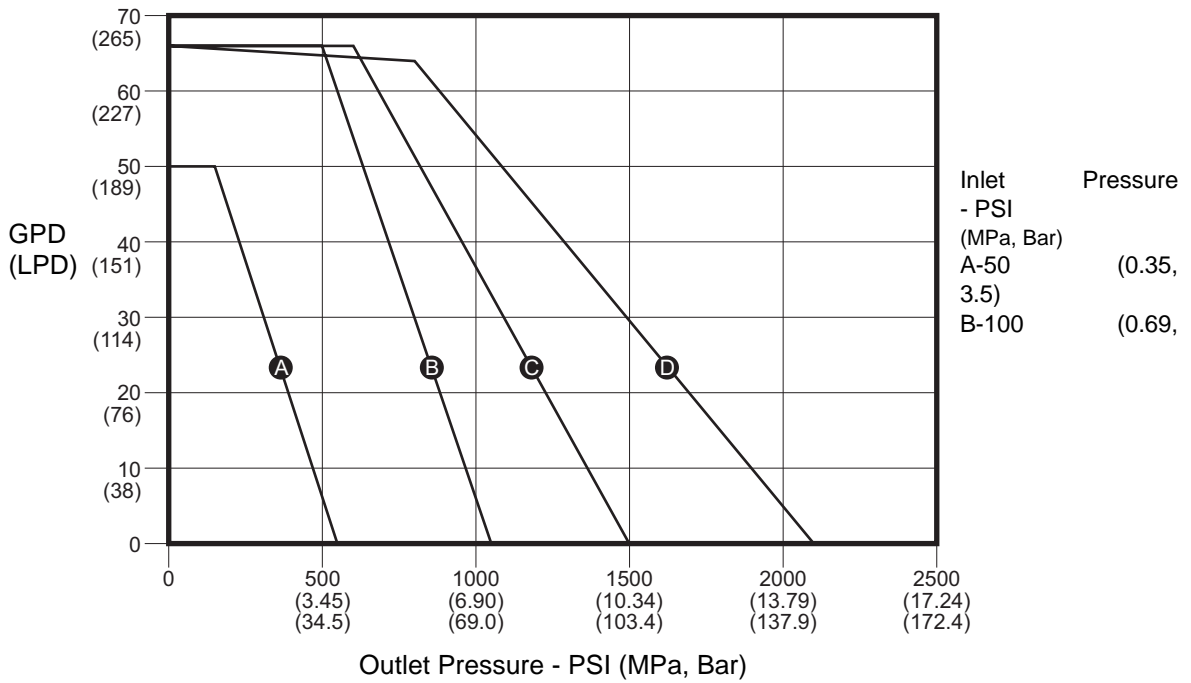

FIG. 49

5/8" Plunger (PCI-200-63)

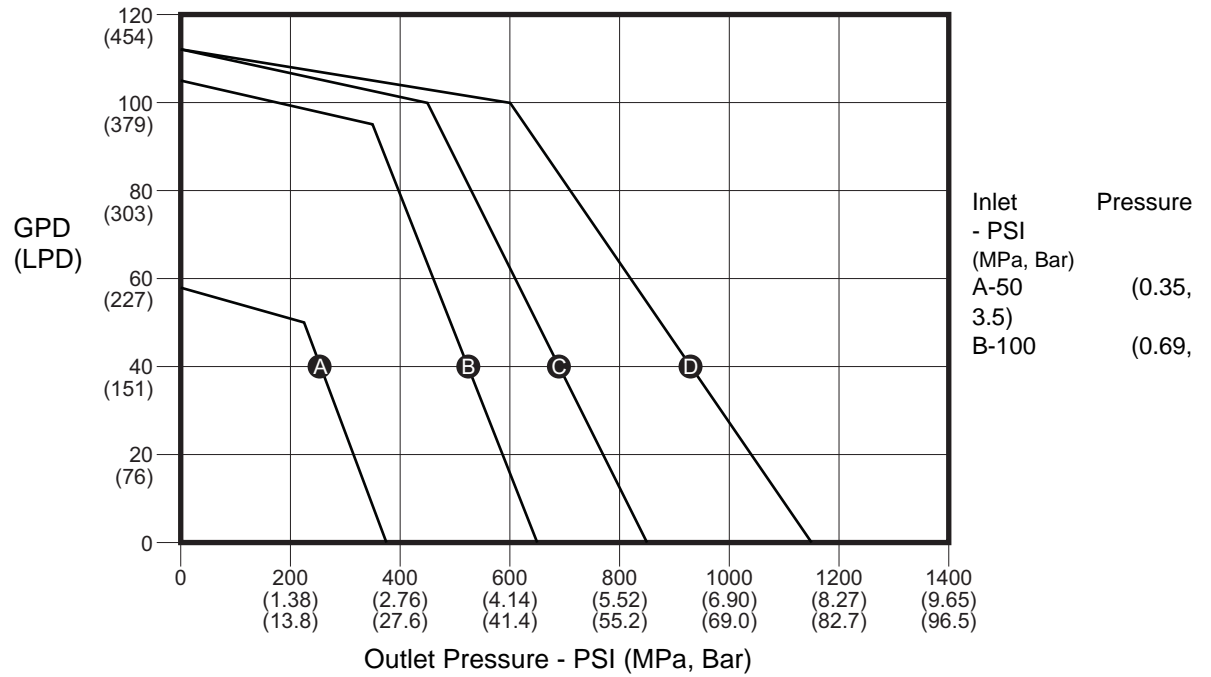

FIG. 50

3/4" Plunger (PCI-200-75)

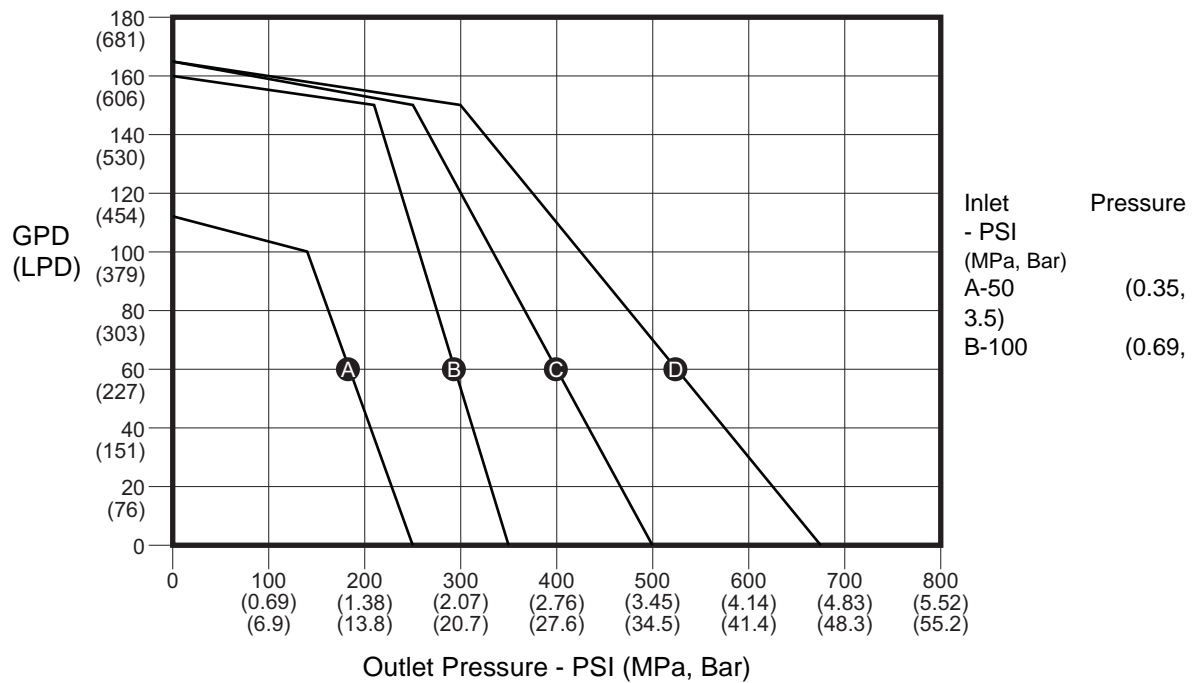

FIG. 51

Technical Data

Python Chemical Injection Pump		
	US	Metric
Maximum air inlet pressure	See Models on page 3.	
Maximum fluid working pressure	See Models on page 3.	
Environmental temperature range	-40°–176°F	-40°–80°C
Noise (dBa)		
Maximum sound pressure	<70 dBa with included muffler installed.	
Inlet/Outlet Sizes		
Fluid inlet size	1/4 in. npt(f) (1/4 npt(m) adapter included)	
Fluid outlet size (1/4", 3/8", 1/2", 5/8", & 3/4" plungers only)	1/4 in. npt(f)	
Fluid outlet size (1/8" & 3/16" plungers only)	HiP HF4	
Prime/bleed size (1/4", 3/8", 1/2", 5/8", & 3/4" plungers only)	10-32 UNF	
Prime/bleed size (1/8" & 3/16" plungers only)	1/16 in. npt(f)	
Pneumatic inlet size	1/8 in. npt(f) (1/4 npt(f) adapter included)	
Pneumatic outlet size (exhaust recovery)	1/8 in. npt(f)	
Materials of Construction		
Pump/Check Valve Seal Material	See Configuration Chart on page 4 for seal material. All other packing materials are PEEK and PTFE unless otherwise noted.	
Wetted Parts	See Configuration Chart on page 4 for plunger material. All other materials are 316 stainless steel unless otherwise noted.	
Weight		
All models	8-11 lbs.	3.6-4.9 kg

California Proposition 65

CALIFORNIA RESIDENTS

 **WARNING:** Cancer and reproductive harm – www.P65warnings.ca.gov.

Graco Standard Warranty

Graco warrants all equipment referenced in this document which is manufactured by Graco and bearing its name to be free from defects in material and workmanship on the date of sale to the original purchaser for use. With the exception of any special, extended, or limited warranty published by Graco, Graco will, for a period of twelve months from the date of sale, repair or replace any part of the equipment determined by Graco to be defective. This warranty applies only when the equipment is installed, operated and maintained in accordance with Graco's written recommendations.

This warranty does not cover, and Graco shall not be liable for general wear and tear, or any malfunction, damage or wear caused by faulty installation, misapplication, abrasion, corrosion, inadequate or improper maintenance, negligence, accident, tampering, or substitution of non-Graco component parts. Nor shall Graco be liable for malfunction, damage or wear caused by the incompatibility of Graco equipment with structures, accessories, equipment or materials not supplied by Graco, or the improper design, manufacture, installation, operation or maintenance of structures, accessories, equipment or materials not supplied by Graco.

This warranty is conditioned upon the prepaid return of the equipment claimed to be defective to an authorized Graco distributor for verification of the claimed defect. If the claimed defect is verified, Graco will repair or replace free of charge any defective parts. The equipment will be returned to the original purchaser transportation prepaid. If inspection of the equipment does not disclose any defect in material or workmanship, repairs will be made at a reasonable charge, which charges may include the costs of parts, labor, and transportation.

THIS WARRANTY IS EXCLUSIVE, AND IS IN LIEU OF ANY OTHER WARRANTIES, EXPRESS OR IMPLIED, INCLUDING BUT NOT LIMITED TO WARRANTY OF MERCHANTABILITY OR WARRANTY OF FITNESS FOR A PARTICULAR PURPOSE.

Graco's sole obligation and buyer's sole remedy for any breach of warranty shall be as set forth above. The buyer agrees that no other remedy (including, but not limited to, incidental or consequential damages for lost profits, lost sales, injury to person or property, or any other incidental or consequential loss) shall be available. Any action for breach of warranty must be brought within two (2) years of the date of sale.

GRACO MAKES NO WARRANTY, AND DISCLAIMS ALL IMPLIED WARRANTIES OF MERCHANTABILITY AND FITNESS FOR A PARTICULAR PURPOSE, IN CONNECTION WITH ACCESSORIES, EQUIPMENT, MATERIALS OR COMPONENTS SOLD BUT NOT MANUFACTURED BY GRACO. These items sold, but not manufactured by Graco (such as electric motors, switches, hose, etc.), are subject to the warranty, if any, of their manufacturer. Graco will provide purchaser with reasonable assistance in making any claim for breach of these warranties.

In no event will Graco be liable for indirect, incidental, special or consequential damages resulting from Graco supplying equipment hereunder, or the furnishing, performance, or use of any products or other goods sold hereto, whether due to a breach of contract, breach of warranty, the negligence of Graco, or otherwise.

FOR GRACO CANADA CUSTOMERS

The Parties acknowledge that they have required that the present document, as well as all documents, notices and legal proceedings entered into, given or instituted pursuant hereto or relating directly or indirectly hereto, be drawn up in English. Les parties reconnaissent avoir convenu que la rédaction du présente document sera en Anglais, ainsi que tous documents, avis et procédures judiciaires exécutés, donnés ou intentés, à la suite de ou en rapport, directement ou indirectement, avec les procédures concernées.

Graco Information

For the latest information about Graco products, visit www.graco.com.

For patent information, see www.graco.com/patents.

TO PLACE AN ORDER, contact your Graco distributor or call to identify the nearest distributor.

Phone: 612-623-6921 **or Toll Free:** 1-800-328-0211 **Fax:** 612-378-3505

All written and visual data contained in this document reflects the latest product information available at the time of publication. Graco reserves the right to make changes at any time without notice.

Original instructions. This manual contains English. MM 3A4386

Graco Headquarters: Minneapolis

International Offices: Belgium, China, Japan, Korea

GRACO INC. AND SUBSIDIARIES • P.O. BOX 1441 • MINNEAPOLIS MN 55440-1441 • USA

Copyright 2015, Graco Inc. All Graco manufacturing locations are registered to ISO 9001.

www.graco.com

Revision E, May 2020