

Python[®] XL-DA25 Pump

3A6831H

EN

Pneumatic pump for injecting chemicals at well sites. Not for use with sour gas. For professional use only.

Not approved for use in European explosive atmosphere locations.

See page 3 for model information, including maximum working pressures.



Important Safety Instructions

Read all warnings and instructions in this manual before using the equipment. Save all instructions.

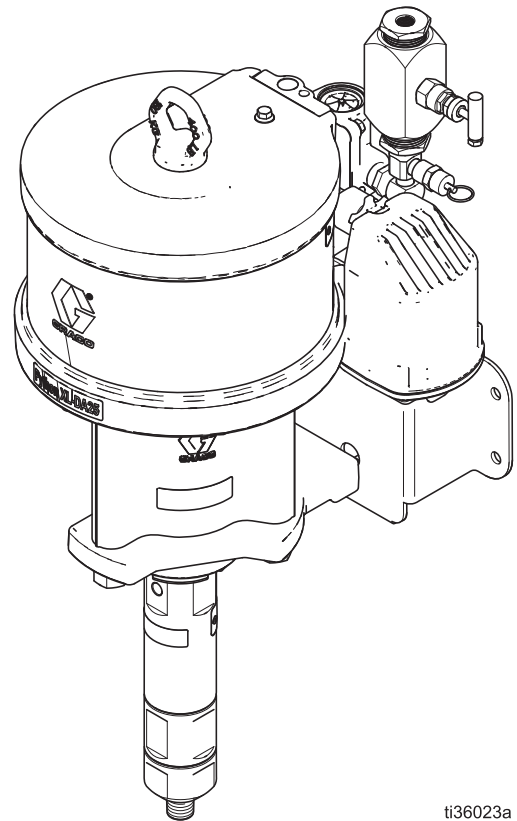

ti36023a



Contents

Models	3	Dimensions	39
Pump Models	3	Python XL-DA25 Pump Dimensions	39
Configuration Number Matrix	4	Wall Bracket Mounting Hole Diagram	40
Pump Configuration	4	Pneumatic Mounting Hole Diagrams	41
Warnings	5	Performance Charts	42
Installation	7	6 in. Motors	42
Grounding	7	7.5 in. Motors	43
Required Accessories	7	1 in. Plunger (PCI-0750-100)	44
Flush Before Using Equipment	7	California Proposition 65	44
Typical Installation	8	Technical Specifications	45
Mount the Pump and Connect Chemical Supply	8	Graco Standard Warranty	46
Connect Pneumatic Supply	9		
Route Exhaust to Remote Location	9		
Connect Chemical Outlet	10		
Operation	13		
Pressure Relief Procedure	13		
Flush the Equipment	13		
Prime the Pump	14		
Calibrate Chemical Dosage	14		
Maintenance	15		
Preventive Maintenance Schedule	15		
Tighten Threaded Connections	15		
Tighten Packings	15		
Storage	15		
Troubleshooting	16		
Repair - Pump Lower	18		
Disconnect the Pump Lower	18		
Pump Repair	19		
Reconnect the Pump Lower	21		
Repair - Pneumatic Motor	22		
Pneumatic Valve	22		
Replace Pilot Valves	25		
Repair Pneumatic Motor	26		
Parts	30		
Python XL-DA25 Pneumatic Pump	30		
Pump Lower	32		
Pneumatic Motor Parts	34		
Pneumatic Valve Parts	36		
Kits and Accessories	38		
Pump Lower Models	38		
Additional Kits & Accessories	38		
AFLAS Air Motor Upgrade Kits	38		

Models

Plunger Size	Pneumatic Motor Size	Pump Working (Stall) Pressure psi (MPa, bar)	Max Dynamic (Run) Pressure psi (MPa, bar)	Max Pneumatic Inlet Pressure psi (MPa, bar)
1/2 in.	6.0 in.	15,000 (103.4, 1034)	11,500 (100.0, 1000)	100 (0.69, 6.9)
3/4 in.		6,400 (44.1, 441)	4,500 (31.0, 310)	
1 in.		3,800 (26.2, 262)	3,500 (24.1, 241)	
3/4 in.	7.5 in.	10,000 (68.9, 689)	7,500 (51.7, 517)	
1 in.		6,100 (42.1, 421)	5,500 (37.9, 379)	

NOTE: See the **Configuration Number Matrix**, page 4, to find the plunger and pneumatic motor size for your unit.

Pump Models

Part Number	Configuration Code	Motor Size	Lower Size	Lower Coating	Seal Material
A22600	PCI-0600-050-075-XC-2-0	6.0 in.	1/2 in.	Chromex	HNBR
A22601	PCI-0600-050-075-XD-2-0				FFKM
A22602	PCI-0600-050-075-XE-2-0				TFE/P
A22606	PCI-0600-075-113-XC-2-0		3/4 in.	Chromex	HNBR
A22607	PCI-0600-075-113-XD-2-0				FFKM
A22608	PCI-0600-075-113-XE-2-0				TFE/P
A22612	PCI-0600-100-138-XC-2-0		1 in.	Chromex	HNBR
A22613	PCI-0600-100-138-XD-2-0				FFKM
A22614	PCI-0600-100-138-XE-2-0	TFE/P			
A22706	PCI-0750-075-113-XC-2-0	7.5 in.	3/4 in.	Chromex	HNBR
A22707	PCI-0750-075-113-XD-2-0				FFKM
A22708	PCI-0750-075-113-XE-2-0				TFE/P
A22712	PCI-0750-100-138-XC-2-0		1 in.	Chromex	HNBR
A22713	PCI-0750-100-138-XD-2-0				FFKM
A22714	PCI-0750-100-138-XE-2-0				TFE/P

Configuration Number Matrix

Check the identification plate (ID) for the 17-digit Configuration Number of your pump. Use the following matrix to define the components of your pump.

NOTE: Not all combinations are possible.

Sample Configuration Number: PCI-0600-075-113-XC-2-0



PCI	0600	075	113	X	C	2	0
Pneumatic Chemical Injection	Pneumatic Motor Size	Pump Lower Primary Seal Size	Pump Lower Secondary Seal Size	Plunger Coating	Seal Material	Pump Stroke Length	Qualifier

Pump Configuration

Pneumatic Motor Size		Pump Lower Primary Seal Size		Pump Lower Secondary Seal Size		Plunger Coating		Seal Material		Pump Stroke Length		Qualifier	
0600	6.0 in.	050	1/2 in. diameter	075	3/4 in. diameter	X	Chromex	C	HNBR	2	2.5 inch	0	None
0750	7.5 in.	075	3/4 in. diameter	113	1-3/8 in. diameter			D	FFKM				
		100	1 in. diameter	138	1-3/8 in. diameter			E	TFE/P				

Warnings

The following warnings are for the setup, use, grounding, maintenance, and repair of this equipment. The exclamation point symbol alerts you to a general warning and the hazard symbols refer to procedure-specific risks. When these symbols appear in the body of this manual or on warning labels, refer back to these Warnings. Product-specific hazard symbols and warnings not covered in this section may appear throughout the body of this manual where applicable.

 <h1 style="margin: 0;">WARNING</h1>	
 	<p>FIRE AND EXPLOSION HAZARD</p> <p>When flammable fluids are present in the work area be aware that flammable fumes can ignite or explode. To help prevent fire and explosion:</p> <ul style="list-style-type: none"> • Use equipment only in well ventilated area. • Eliminate all ignition sources, such as cigarettes and portable electric lamps. • Ground all equipment in the work area. • Keep work area free of debris, including rags and spilled or open containers of solvent. • Do not plug or unplug power cords or turn lights on or off when flammable fumes are present. • Use only grounded hoses. • Stop operation immediately if static sparking occurs or you feel a shock. Do not use equipment until you identify and correct the problem. • Keep a working fire extinguisher in the work area.
    	<p>SKIN INJECTION HAZARD</p> <p>High-pressure fluid from dispensing device, hose leaks, or ruptured components will pierce skin. This may look like just a cut, but it is a serious injury that can result in amputation. Get immediate surgical treatment.</p> <ul style="list-style-type: none"> • Do not put your hand over the fluid outlet. • Do not stop or deflect leaks with your hand, body, glove, or rag. • Follow the Pressure Relief Procedure when you stop dispensing and before cleaning, checking, or servicing equipment. • Tighten all fluid connections before operating the equipment. • Check hoses and couplings daily. Replace worn or damaged parts immediately.
	<p>TOXIC FLUID OR FUMES HAZARD</p> <p>Toxic fluids or fumes can cause serious injury or death if splashed in the eyes or on skin, inhaled, or swallowed.</p> <ul style="list-style-type: none"> • Read Safety Data Sheet (SDS) to know the specific hazards of the fluids you are using. • Store hazardous fluid in approved containers, and dispose of it according to applicable guidelines.

⚠️ WARNING



PERSONAL PROTECTIVE EQUIPMENT

Wear appropriate protective equipment when in the work area to help prevent serious injury, including eye injury, hearing loss, inhalation of toxic fumes, and burns. Protective equipment includes but is not limited to:

- Protective eyewear, and hearing protection.
- Respirators, protective clothing, and gloves as recommended by the fluid and solvent manufacturer.





EQUIPMENT MISUSE HAZARD

Misuse can cause death or serious injury.

- Do not operate the unit when fatigued or under the influence of drugs or alcohol.
- Do not exceed the maximum working pressure or temperature rating of the lowest rated system component. See **Technical Data** in all equipment manuals.
- Use fluids and solvents that are compatible with equipment wetted parts. See **Technical Data** in all equipment manuals. Read fluid and solvent manufacturer's warnings. For complete information about your material, request Safety Data Sheet (SDS) from distributor or retailer.
- Turn off all equipment and follow the **Pressure Relief Procedure** when equipment is not in use.
- Check equipment regularly. Repair or replace worn or damaged parts immediately with genuine manufacturer's replacement parts only.
- Do not alter or modify equipment. Alterations or modifications may void agency approvals and create safety hazards.
- Make sure all equipment is rated and approved for the environment in which you are using it.
- Use equipment only for its intended purpose. Call your distributor for information.
- Route hoses and cables away from traffic areas, sharp edges, moving parts, and hot surfaces.
- Do not kink or over bend hoses or use hoses to pull equipment.
- Keep children and animals away from work area.
- Comply with all applicable safety regulations.



Installation

				
---	---	---	--	--

If using a flammable gas to drive the motor, to reduce the risk of fire or explosion, route the exhaust away from all sources of ignition. See **Route Exhaust to Remote Location** on page 9.

NOTE: A small amount of the exhaust is not recoverable, and will vent to atmosphere at the pump. However, a 100% Exhaust Capture Kit, B32651, is available.

To reduce the risk of injury from ejected ice, do not operate the motor without a plumbed exhaust line or muffler installed.

Installation must comply with all local codes and regulations.

Grounding

				
---	---	---	--	--

The equipment must be grounded to reduce the risk of static sparking. Static sparking can cause fumes to ignite or explode. Grounding provides an escape wire for the electric current.

Pump: ground through electrically conductive pneumatic and fluid lines.

Pneumatic and fluid lines: use only electrically conductive lines.

Air compressor: follow manufacturer's recommendations.

Fluid supply container: follow local code.

Required Accessories

Install the following required accessories as shown in FIG. 1, using adapters as necessary.

Pneumatic Line

- **Primary bleed-type master pneumatic valve (D):** required in your system to relieve air/gas trapped between it and the pneumatic motor when the valve is closed.
 - Be sure the valve is easily accessible from the pump and located downstream from the pneumatic pressure regulator.
- **Pump pneumatic pressure regulator (E):** to control pump speed and outlet pressure. Locate it close to the pump.
- **Pneumatic filter (C):** removes harmful dirt and moisture from compressed air/gas supply.
- **Secondary bleed-type pneumatic valve (pneumatic shutoff valve) (B):** isolates pneumatic line accessories for servicing. Locate upstream from all other pneumatic line accessories.

Fluid Line

- **Fluid filter (Y-strainer) (included in G):** with a 60 mesh (250 micron) stainless steel element to filter particles from the fluid before it reaches the pump.
- **Fluid shutoff valve (H):** shuts off fluid flow.
- **Pressure relief valve (J):** overload protection.

Flush Before Using Equipment

The equipment was tested with lightweight oil, which is left in the fluid passages to protect parts. To avoid contaminating your fluid with oil, flush the equipment with a compatible solvent before using the equipment. See **Flush the Equipment**, page 13.

Typical Installation

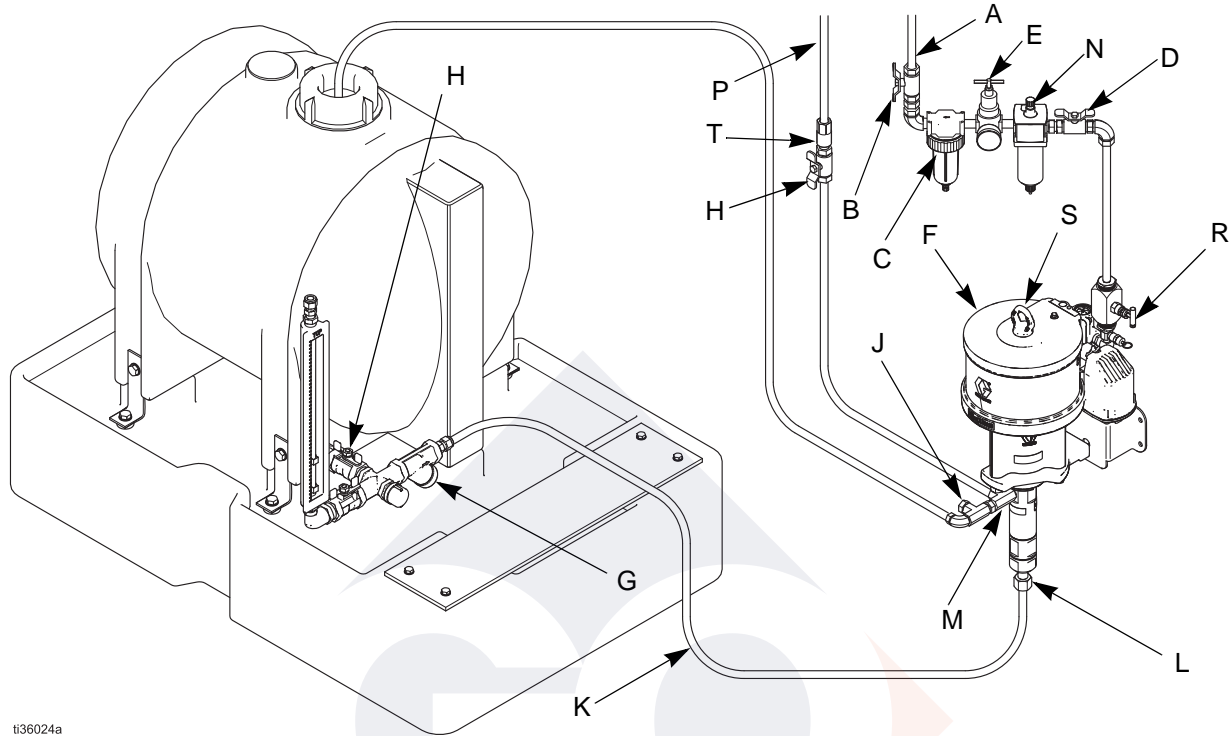

ti36024a

FIG. 1:

FIG. 1 is an example of an installation with a Python XL-DA25 chemical injection pump. Your installation may differ from what is shown here. (See **Required Accessories**, page 7.) The Python XL-DA25 pump (F) and secondary bleed-type pneumatic valve (B) are the only components in FIG. 1 supplied by Graco. All other components are supplied by customer.

Key:

- A Main pneumatic supply line
- B Secondary bleed-type pneumatic valve
- C Pneumatic filter
- D Primary bleed-type master pneumatic valve
- E Pneumatic pressure regulator
- F Pump
- G Manifold assembly (includes Y-strainer and fluid shutoff valve (H))
- H Fluid shutoff valve (inlet & outlet)
- J Fluid pressure relief valve
- K Fluid inlet line
- L Inlet port
- M Outlet port
- N Pneumatic lubricator
- P Fluid outlet line
- R Speed control valve
- S Lift ring (for lifting the pump only)
- T Check valve

Mount the Pump and Connect Chemical Supply



The pump can be bolted to a wall or skid by the attached bracket.

NOTE: The pump must always be mounted vertically.

If you have an application, or mounting configuration, that requires installation in a manner different than depicted in FIG. 1, please contact your Graco distributor for assistance.

NOTE: A Y-strainer (G) or chemical filter is required before the pump inlet. This will keep debris from the tank from reaching the pump seals. Fluid filters are available from Graco.

1. Mount the pump (F) and connect the fluid inlet line (K).

Connect Pneumatic Supply

1. Install the pneumatic pressure regulator (E) and gauge to control the inlet pressure. See **Models** on page 3 for your model's maximum pneumatic pressure.

NOTE: If less than 100 psi supply pressure is used, the pump's maximum output pressure will be decreased proportionally.

Minimum pneumatic pressure can be found by first finding the table that corresponds to the pneumatic motor size (see **Minimum Pneumatic Pressures by Fluid Plunger Size and Outlet Pressures** on page 11). Next, using the column that corresponds to the plunger size, find the row equal to or slightly greater than the outlet pressure of the pump. The value is the minimum pneumatic pressure required to achieve the fluid outlet pressure.

2. Install a pneumatic filter (C) to keep debris from affecting pump performance and to increase pump life.

NOTE: Keep the secondary bleed-type pneumatic valve (B) closed at this point to keep the pump from operating without fluid, which minimizes seal wear.

3. Attach a pneumatic line to the 1/4 in. female NPT port on the secondary bleed-type pneumatic valve (B).

NOTE: In some applications the air source may contain solvents that can breakdown the factory grease in the air motor. This may cause the air motor to stall. If the air motor stalls, then install an in-line pneumatic lubricator. See **Kits and Accessories** on page 38 for the recommended pneumatic lubricator

Route Exhaust to Remote Location

Replace the muffler (18) with a pneumatic line to route exhaust to a remote location.





NOTICE

Due to the operational design of the pneumatic valve, a small amount of the exhaust is not recoverable, and will vent to atmosphere. However, a 100% Exhaust Capture Kit, B32651, is available.

Connect Chemical Outlet

1. Connect a fluid line from the pump outlet port (M) to the injection point.
2. Install a check valve (T).
3. Install a fluid pressure relief valve (J) on the outlet side of the pump.

NOTE: A pressure relief valve is required and is available from Graco, and can be connected back to the tank or directly to the inlet side of the pump. See **Kits and Accessories** on page 38.

				
In the event of an injection line blockage, to reduce the risk of skin injection and damage to the pump, ensure the pressure relief valve is set at or below the maximum working pressure of the pump.				

4. Set the pressure relief valve at or below the maximum working pressure of the pump.

goind.com.au

Minimum Pneumatic Pressures by Fluid Plunger Size and Outlet Pressures

Actual running pressure must be set in field to avoid stalling. See **Performance Charts**, starting on page 42, for maximum flows at any given pressure.

0600 (6.0 in) Pneumatic Motor Minimum Gas Pressure <i>psi (MPa, bar)</i>			
Outlet Pressure psi (MPa, bar)	1/2 Inch Fluid Plunger	3/4 Inch Fluid Plunger	1 Inch Fluid Plunger
0 (0, 0)	15.0 (0.1, 1.0)	15.0 (0.1, 1.0)	15.0 (0.1, 1.0)
500 (3.4, 34.5)	15.0 (0.1, 1.0)	15.0 (0.1, 1.0)	15.0 (0.1, 1.0)
1000 (6.9, 68.9)	15.0 (0.1, 1.0)	15.6 (0.1, 1.1)	26.3 (0.2, 1.8)
1500 (10.3, 103.4)	15.0 (0.1, 1.0)	23.4 (0.2, 1.6)	39.5 (0.3, 2.7)
2000 (13.8, 137.9)	15.0 (0.1, 1.0)	31.3 (0.2, 2.2)	52.6 (0.4, 3.6)
2500 (17.2, 172.4)	17.4 (0.1, 1.2)	39.1 (0.3, 2.7)	65.8 (0.5, 4.5)
3000 (20.7, 206.8)	20.8 (0.1, 1.4)	46.9 (0.3, 3.2)	79.0 (0.5, 5.4)
3500 (24.1, 241.3)	24.3 (0.2, 1.7)	54.7 (0.4, 3.8)	92.1 (0.6, 6.4)
3800 (26.2, 262.0)	26.4 (0.2, 1.8)	59.4 (0.4, 4.1)	100.0 (0.7, 6.9)
4000 (27.6, 275.8)	27.8 (0.2, 1.9)	62.5 (0.4, 4.3)	
4500 (31.0, 310.3)	31.3 (0.2, 2.2)	70.3 (0.5, 4.8)	
5000 (34.5, 344.7)	34.7 (0.2, 2.4)	78.1 (0.5, 5.4)	
5500 (37.9, 379.2)	38.2 (0.3, 2.6)	85.9 (0.6, 5.9)	
6000 (41.4, 413.7)	41.7 (0.3, 2.9)	93.8 (0.6, 6.5)	
6400 (44.1, 441.3)	44.4 (0.3, 3.1)	100.0 (0.7, 6.9)	
6500 (44.8, 448.2)	45.1 (0.3, 3.1)		
7000 (48.3, 482.6)	48.6 (0.3, 3.4)		
7500 (51.7, 517.1)	52.1 (0.4, 3.6)		
8000 (55.2, 551.6)	55.6 (0.4, 3.8)		
8500 (58.6, 586.1)	59.0 (0.4, 4.1)		
9000 (62.1, 620.5)	62.5 (0.4, 4.3)		
9500 (65.5, 655.0)	66.0 (0.5, 4.5)		
10000 (68.9, 689.5)	69.4 (0.5, 4.8)		
10500 (72.4, 723.9)	72.9 (0.5, 5.0)		
11000 (75.8, 758.4)	76.4 (0.5, 5.3)		
11500 (79.3, 792.9)	79.9 (0.6, 5.5)		
12000 (82.7, 827.4)	83.3 (0.6, 5.7)		
12500 (86.2, 861.8)	86.8 (0.6, 6.0)		
13000 (89.6, 896.3)	90.3 (0.6, 6.2)		
13500 (93.1, 930.8)	93.8 (0.6, 6.5)		
14000 (96.5, 965.3)	97.2 (0.7, 6.7)		
14400 (99.3, 992.8)	100.0 (0.7, 6.9)		

For applications where the exhaust is ported to a pressurized location, compute the difference between the inlet and outlet pressures to get the pneumatic pressure to be used in the above tables. Minimum pressure differential is 15 psi (0.1 MPa, 1.0 bar).

0750 (7.5 in) Pneumatic Motor Minimum Gas Pressure psi (MPa, bar)		
Outlet Pressure psi (MPa, bar)	3/4 Inch Fluid Plunger	1 Inch Fluid Plunger
0 (0, 0)	15.0 (0.1, 1.0)	15.0 (0.1, 1.0)
500 (3.4, 34.5)	15.0 (0.1, 1.0)	15.0 (0.1, 1.0)
1000 (6.9, 68.9)	15.0 (0.1, 1.0)	16.4 (0.1, 1.1)
1500 (10.3, 103.4)	15.0 (0.1, 1.0)	24.6 (0.2, 1.7)
2000 (13.8, 137.9)	20.0 (0.1, 1.4)	32.8 (0.2, 2.3)
2500 (17.2, 172.4)	25.0 (0.2, 1.7)	41.0 (0.3, 2.8)
3000 (20.7, 206.8)	30.0 (0.2, 2.1)	49.2 (0.3, 3.4)
3500 (24.1, 241.3)	35.0 (0.2, 2.4)	57.4 (0.4, 4.0)
4000 (27.6, 275.8)	40.0 (0.3, 2.8)	65.6 (0.5, 4.5)
4500 (31.0, 310.3)	45.0 (0.3, 3.1)	73.8 (0.5, 5.1)
5000 (34.5, 344.7)	50.0 (0.3, 3.4)	82.0 (0.6, 5.7)
5500 (37.9, 379.2)	55.0 (0.4, 3.8)	90.2 (0.6, 6.2)
6000 (41.4, 413.7)	60.0 (0.4, 4.1)	98.4 (0.7, 6.8)
6100 (42.1, 420.6)	61.0 (0.4, 4.2)	100.0 (0.7, 6.9)
6500 (44.8, 448.2)	65.0 (0.4, 4.5)	
7000 (48.3, 482.6)	70.0 (0.5, 4.8)	
7500 (51.7, 517.1)	75.0 (0.5, 5.2)	
8000 (55.2, 551.6)	80.0 (0.6, 5.5)	
8500 (58.6, 586.1)	85.0 (0.6, 5.9)	
9000 (62.1, 620.5)	90.0 (0.6, 6.2)	
9500 (65.5, 655.0)	95.0 (0.7, 6.6)	
10000 (68.9, 689.5)	100.0 (0.7, 6.9)	

For applications where the exhaust is ported to a pressurized location, compute the difference between the inlet and outlet pressures to get the pneumatic pressure to be used in the above tables. Minimum pressure differential is 15 psi (0.1 MPa, 1.0 bar).

Operation

Pressure Relief Procedure

 Follow the Pressure Relief Procedure whenever you see this symbol.



This equipment stays pressurized until pressure is manually relieved. To help prevent serious injury from pressurized fluid, such as skin injection and splashing fluid, follow the **Pressure Relief Procedure** when you stop dispensing and before cleaning, checking, or servicing the equipment.

NOTE: Always discharge fluid into an approved container or location.

1. Shut off all fluid and pneumatic lines (A, K, & P) using the two fluid shutoff valves (H) and the secondary bleed-type pneumatic valve (B).
2. Slowly loosen the inlet and outlet fluid lines (K & P) at the pump (L & M) to bleed off any residual pressure.

Flush the Equipment

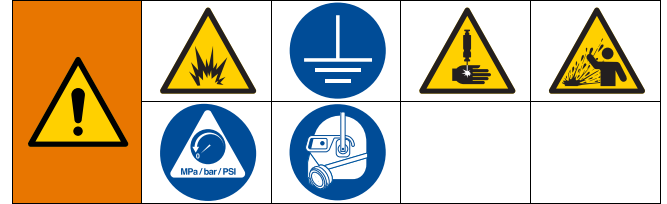

To avoid fire and explosion, always ground equipment and waste container. To avoid static sparking and injury from splashing, always flush at the lowest possible pressure.

- Flush with a fluid that is compatible with the fluid being dispensed and the equipment wetted parts.
1. Follow the **Pressure Relief Procedure**.
 2. Disconnect the inlet and outlet fluid lines (K & P) from the pump (L & M).
 3. Connect the inlet port to the flushing fluid supply source.
 4. Connect the outlet port to the waste reservoir.
 5. Run the pump until the dispensed fluid is predominately flushing fluid.
 6. Follow the **Pressure Relief Procedure**.
 7. Connect the inlet and outlet fluid lines (K & P) to the pump (L & M).

Prime the Pump



1. Verify all connections and fluid lines are tight.

NOTE: The pneumatic pressure regulator (E) and speed control valve (R) (needle valve) both affect the pump cycle rate. After inlet pressure is set, the needle valve can serve as a speed control.

2. Adjust the pneumatic pressure regulator (E) to desired pressure.
3. Open the primary bleed-type master pneumatic valve (D). Slowly turn the speed control valve (R) counter-clockwise, increasing air/gas flow to the pump.

NOTICE

Pump runaway may occur if the speed control valve (R) is opened too far for pressure settings, causing damage to the packing sets (102 and 107).

4. Keep the pump cycle rate less than 1 cycle every 3 seconds while priming the pump.

Calibrate Chemical Dosage



1. Set the pump to an estimated setting of the flow rate.
2. Follow the instructions provided with your calibration gauge.
3. Adjust the cycle rate with the speed control valve (R) and/or the pneumatic pressure regulator (E).
4. Repeat the steps 2 and 3 to verify your changes. Repeat as necessary until the desired flow rate is achieved.

Baseline Chemical Dosage Settings

See **Performance Charts**, starting on page 42, for maximum flows at any given pressure.

CPM	1/2 in. Fluid Plunger Pumps		3/4 in. Fluid Plunger Pumps		1 in. Fluid Plunger Pumps	
	GPD	LPD	GPD	LPD	GPD	LPD
10	71	269	180	680	269	1017
20	142	537	359	1360	537	2033
30	213	806	539	2041	806	3050
40	284	1075	719	2721	1074	4066
50	355	1344	899	3401	1343	5083
60	426	1612	1078	4081	1611	6100

NOTICE

Maximum cycle rate is 60 CPM (cycles per minute), and the minimum cycle rate is 10 CPM. All values are at 0 psi back pressure. Cycle rates over 60 may cause excess wear and premature seal failure.

Maintenance

Preventive Maintenance Schedule

The operating conditions of your particular pump determine how often maintenance is required. Establish a preventive maintenance schedule by recording when and what kind of maintenance is needed, and then determine a regular schedule for checking your pump.

Tighten Threaded Connections

Check that all threaded connections are tight before each use and at routine intervals.

Tighten Packings

The packings included in your pump have the ability to be adjusted to stop leaks that develop when the seals are worn. If a leak develops in the pump's fluid section, tighten the packing nut clockwise by 1/16 of a turn, or lower, until the leak is eliminated. The life of the packing can be affected by over-tightening the packings. If the packing nut needs to be tightened repeatedly after short intervals, replace the packing.

Storage

If the pump is going to be stored for long periods, flush the pump with a light-weight oil or rust prohibiter before storage to protect pump components. Store the pump with protective fluid inside whenever possible.

Troubleshooting

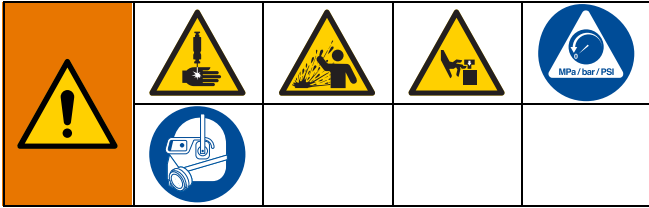

1. Follow **Pressure Relief Procedure**, page 13, before checking or repairing pump.
2. Check all possible problems and causes before dis-assembling pump.

Problem	Cause	Solution
Pump runs, but the chemical does not discharge at the correct rate.	Inlet check is clogged with debris.	Remove debris from check valve.
	Inlet check o-ring is damaged.	Evaluate the o-ring chemical compatibility, and replace as required.
	Air is in the pump head.	Ensure suction lines are tight, and then prime the pump.
		When injecting into a gas line, inspect the outlet check valve to ensure gas is not back feeding into the pump head.
	Packing leak.	Tighten packing nut. If leak persists then evaluate packing chemical compatibility, and replace.
	Inadequate chemical supply.	Ensure the chemical tank is filled.
		Inspect and replace chemical supply filter.
Incorrect calibration.	Ensure the calibration gauge is functioning properly with adequate venting.	
Problem	Cause	Solution
Pump does not stroke.	Inadequate pneumatic supply.	If the pressure is too low then increase the pneumatic supply pressure.
		If the volume is too low, then ensure the pneumatic supply volume is adequate to operate the pump.
	Dirty supply gas.	Install a filter
		Replace the filter element
	Inadequate internal lubrication.	Ensure pneumatic supply gas is clean and dry with a working filter. Then lubricate the air motor internals.
		Add an oiler if pneumatic supply gas contains solvents that are washing out the factory grease. Graco oiler 237212.
	Inconsistent pump changeover.	Replace the pilot valves.
	Stalling on one end of the stroke.	Rebuild or replace the pneumatic valve.
Replace pilot valves.		
Air is continuously exhausting from muffler.	Rebuild or replace pneumatic valve.	
Air is continuously exhausting from motor piston rod.	Replace the piston rod u-cup.	

Problem	Cause	Solution
Chemical is leaking from packing.	Worn packing	Tighten the packing nut. If leaking persists then replace packing. NOTE: the packing nut is set from the factory, and does not require tightening upon initial installation.
		Consult the Chemical Compatibility Guide to ensure the seal in use is compatible with the chemicals being pumped. NOTE: The Chemical Compatibility Guide can be found at www.graco.com .
		Consult the Chemical Compatibility Guide to ensure the seal in use is designed to operate in the recommended temperature range. NOTE: The Chemical Compatibility Guide can be found at www.graco.com .
		Inspect the plunger for coating failure due to chemical or abrasive attack. Replace plunger as required.
Problem	Cause	Solution
Icing inside motor.	Pneumatic motor is operating at a high pressure or high cycle rate.	Reduce pressure, cycle rate, or duty cycle of motor.
		Reduce the dew-point of compressed air in the moisture coalescing filter.
Erratic or accelerated pump speed.	Exhausted fluid supply.	Replace and reprime.
	Worn or clogged check valves or packing.	Remove debris from check valve.
		Replace check valve.

Repair - Pump Lower



Before servicing or repairing your pump, verify that pressure is relieved according to the **Pressure Relief Procedure**, page 13, and that all fluid and pneumatic lines are properly shut off.

- Always use Genuine Graco Parts and Accessories, available from your Graco distributor. If you supply your own accessories, be sure they are adequately sized and pressure rated for your system.

Disconnect the Pump Lower



Threads are very sharp. Use a rag to protect hands when turning or carrying the pump.

1. Stop the pump in the middle of the stroke.
2. Follow the **Pressure Relief Procedure**, page 13.
3. Disconnect the fluid lines.
4. Loosen the screw (16) and remove the tie rod shield (15). The drip shield (4) may slide down the tie rods once the rod shield is removed.

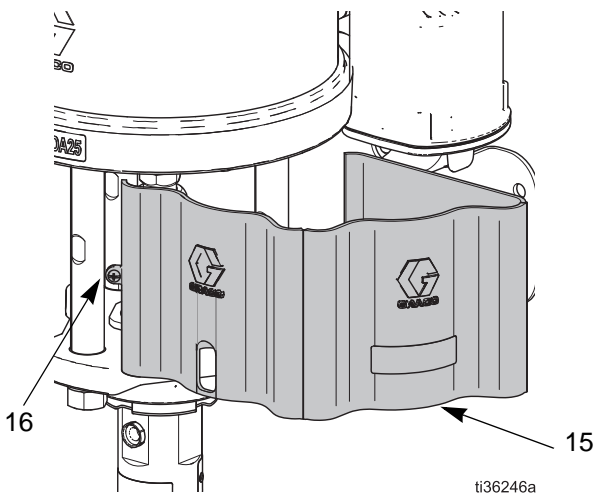

FIG. 2

5. Hold the drip shield (4) out of the way if it is blocking the pneumatic motor plunger (206). Hold the flats of the pneumatic motor plunger (206) with a wrench. Use another wrench to loosen the coupler nut (11).

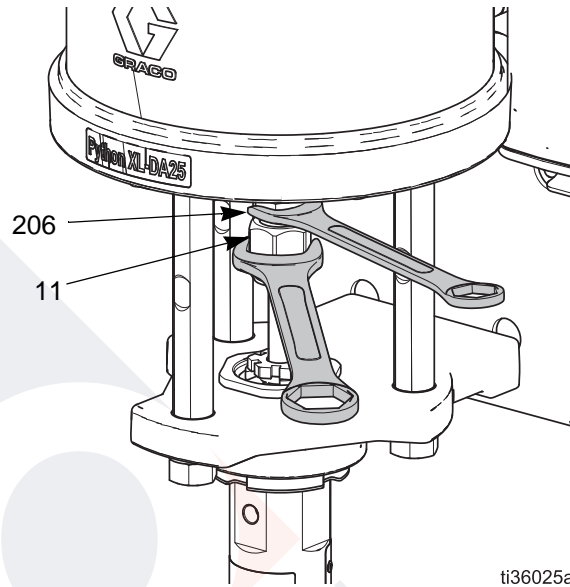

FIG. 3

6. Lower the coupler nut (11) enough to remove the coupling collars (10), and then remove the coupler nut (11).

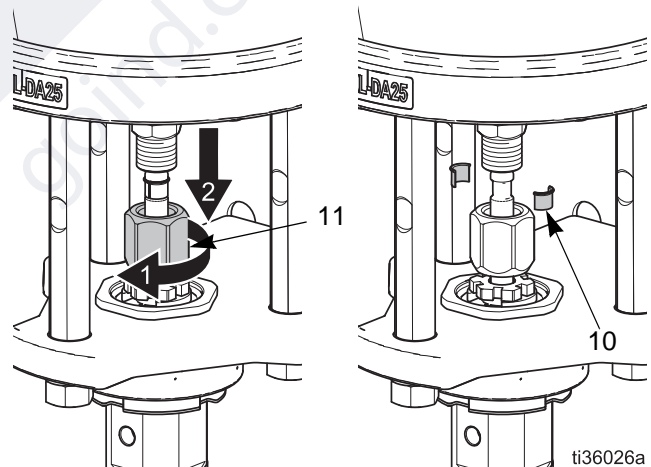

FIG. 4

7. Use a hammer and brass rod to loosen the jam nut (119). Unscrew the jam nut as far as possible.

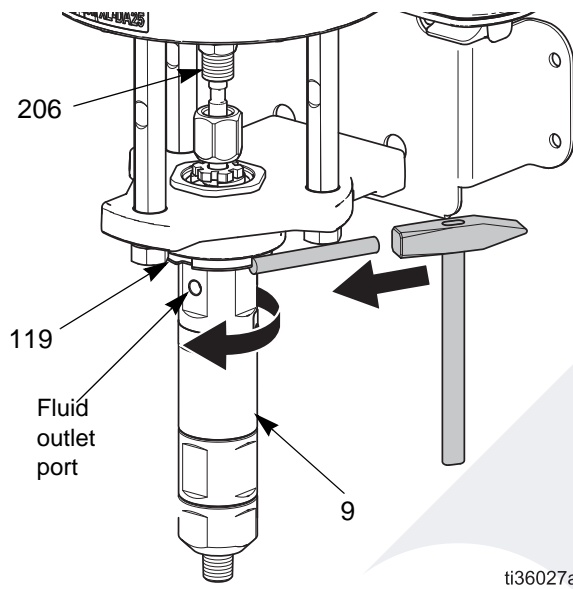

FIG. 5

8. Unscrew the pump lower (9) by hand and place on work bench.

Pump Repair

1. Remove the lower fluid cylinder (113) and cylinder cap (117) assembly from the primary fluid cylinder (101).

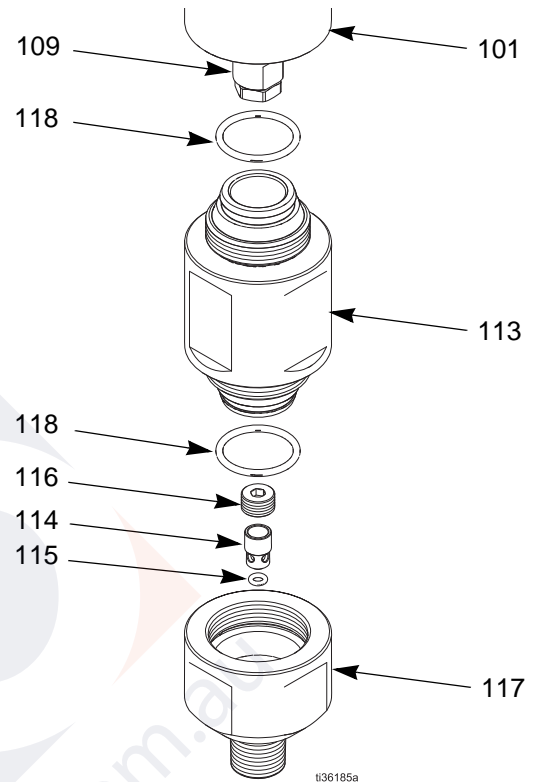

FIG. 6

2. Remove the cylinder cap (117) from the lower fluid cylinder (113).
3. Remove the plunger (109).
4. Remove the cylinder cap check valve retainer (116) and cylinder cap check valve poppet (114).

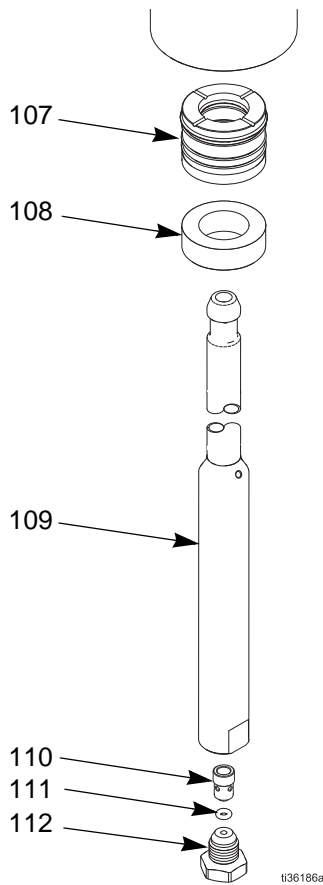

FIG. 7

5. Remove the plunger check valve seat (112) and plunger check valve poppet (110).
6. Remove the o-rings (118) from the lower fluid cylinder (113).
7. Remove the bearing (108) and secondary seal stack (107) from the fluid cylinder (101).
8. Remove the packing nut (106), shim (105), bearing (103) and primary seal stack (102) from the fluid cylinder (101).

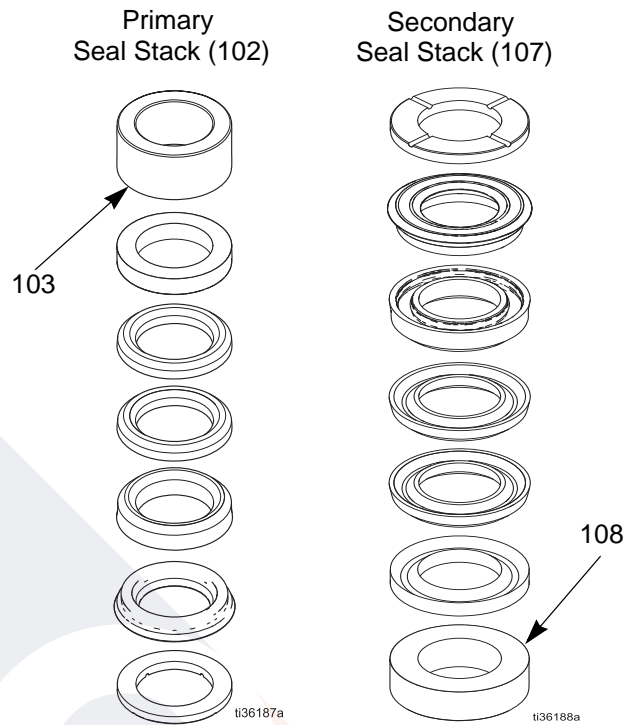

FIG. 8

9. Install the new primary seal stacking (102) including bearing (103). Use grease during installation.
10. Install the packing nut (106) with pipe sealant until finger tight.

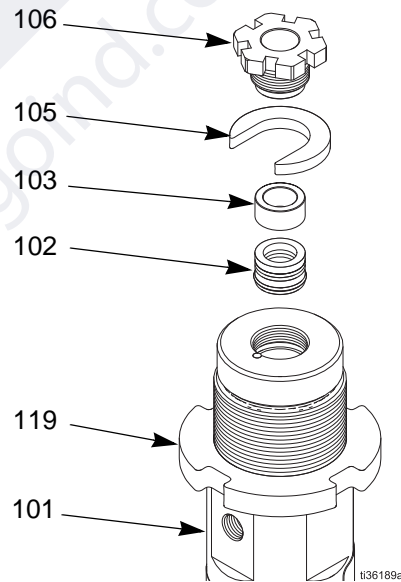

FIG. 9

11. Install the new secondary seal stack (107), including bearing (108). Use grease during installation.

12. Install two new o-rings (118) on the lower fluid cylinder (113). Orientation does not matter for this part.
13. Apply anti-seize compound to both lower fluid cylinder (113) threads and install into the fluid cylinder (101). Torque to 100 ft-lbs (136 N•m).
14. Inspect and replace the plunger o-ring (111), as required, and insert the plunger poppet (110) into the plunger (109) as shown in FIG. 7. Apply medium strength (blue) thread locker to the check seat (112). Torque to the following values depending on the size of your pump lower:

Pump Lower Size	Torque
050 and 075	40 ft-lbs (54 N•m)
100	90 ft-lbs (122 N•m)

15. Apply petroleum-based lubricant to the fluid plunger (109) and install into the fluid cylinder (101).
16. Inspect and replace the cylinder o-ring (115), as required, and insert the cylinder poppet (114) into the cylinder cap (117) as shown in FIG. 6. Install the check retainer (116). Torque to 10 ft-lb (14 N•m).
17. Install the cylinder cap (117) onto the lower fluid cylinder (113). Torque to 100 ft-lbs (136 N•m).
18. Install the packing nut shim (105) and torque the packing nut (106) to 20 ft-lbs (27 N•m).

Reconnect the Pump Lower

1. Tilt the pneumatic motor (1) onto its back, then hand turn the pump lower (9) into the adapter plate (6). Set the pump upright again.
2. Hold the pneumatic motor plunger (109) up with one hand. With your other hand, put the coupler nut (11) on the plunger.

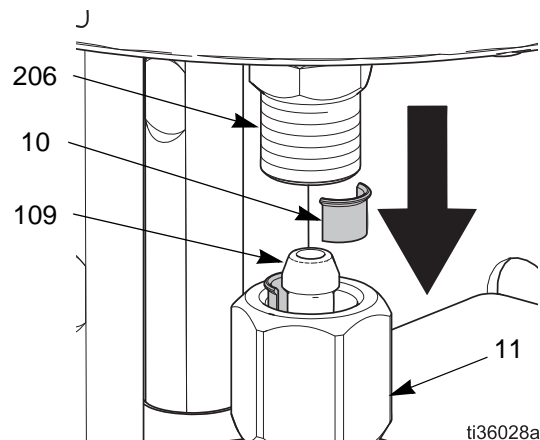

FIG. 10

3. Put the coupling collars (10) into the coupler nut (11) so the large flanges point upward.
4. Gently let the pneumatic motor plunger (206) drop onto the fluid plunger (109). Hand tighten the coupler nut (11).
5. Screw the pump lower (9) into the adapter nut (5) until the cylinder top is flush with the top of the adapter plate (6).

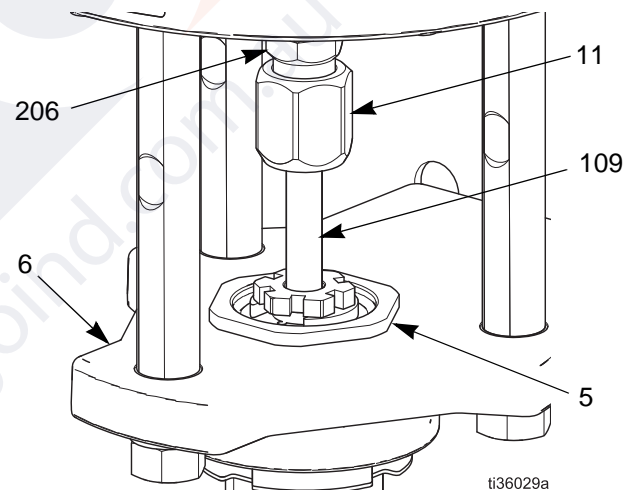

FIG. 11

6. Align the fluid outlet port away from the mounting bracket, as shown in FIG. 5, and tighten the jam nut (119).
7. Hold the flats of the motor plunger (206) with a wrench. Use another wrench to tighten the coupler nut (11). Torque the coupler nut (11) to 75-80 ft-lbs (102-108 N•m).
8. Hold the drip shield (4) out of the way and replace the tie rod shield (15).

Repair - Pneumatic Motor



Pneumatic Valve

Replace Complete Pneumatic Valve

1. Stop the pump. Follow **Pressure Relief Procedure**, page 13.
2. Disconnect the pneumatic line to the motor.
3. See the figure on page 34. Remove four screws (218). Remove the pneumatic valve (217) and gasket (216*♦).
4. To repair the pneumatic valve, go to **Disassemble the Pneumatic Valve**, page 22. To install a replacement pneumatic valve (217), continue with step 5.
5. Align the new pneumatic valve gasket (216*♦) on the manifold, then attach the pneumatic valve (217). Torque screws (218) to 95-105 in-lb (11-12 N•m).
6. Reconnect the pneumatic line to the motor.

Replace Seals or Rebuild Pneumatic Valve

Inspect and replace seals and worn parts while disassembling and reassembling the pneumatic valve on the next following pages.

Use FIG. 12 and the following table to identify the kits needed for replacements:

Symbol	Kit Description
†	Pneumatic Valve Seal Kits. See page 37
♦	Pneumatic Valve Repair Kits. See page 37.
⌘	Pneumatic Valve End Cap Kits. See page 37.

Disassemble the Pneumatic Valve

1. Perform steps 1-3 under **Replace Complete Pneumatic Valve**, page 22.
2. See FIG. 12. Use a 2 mm or 5/64 in. hex key to remove two screws (309†♦). Remove the valve plate (305♦), cup (312♦), and spring (311♦).
3. See FIG. 12. Remove the snap ring (310♦⌘) from each end. Use the piston to push the end caps (307⌘) out of the ends. Remove end cap o-rings (306†⌘♦).
4. Remove the piston (302♦). Remove the u-cup seals (308†♦) from each end, and the detent assembly (303♦) and detent cam (304♦) from the center.

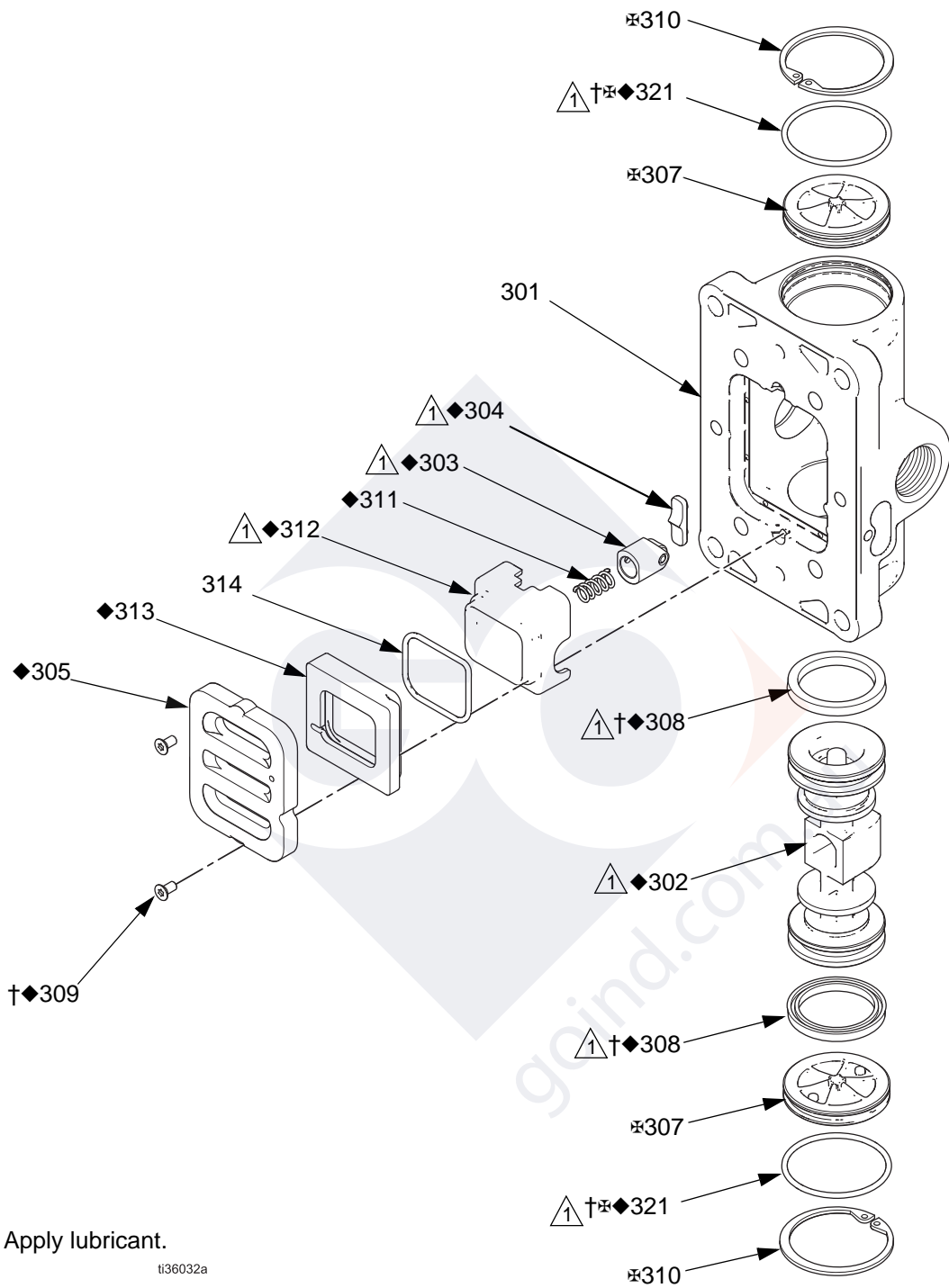

FIG. 12

ti16213a

Reassemble the Pneumatic Valve

1. See FIG. 12. Lubricate detent cam (304♦) and install into housing.
2. See FIG. 13. Lubricate the u-cups (308†♦) and install on the piston (302♦) with lips facing toward the center of the piston.

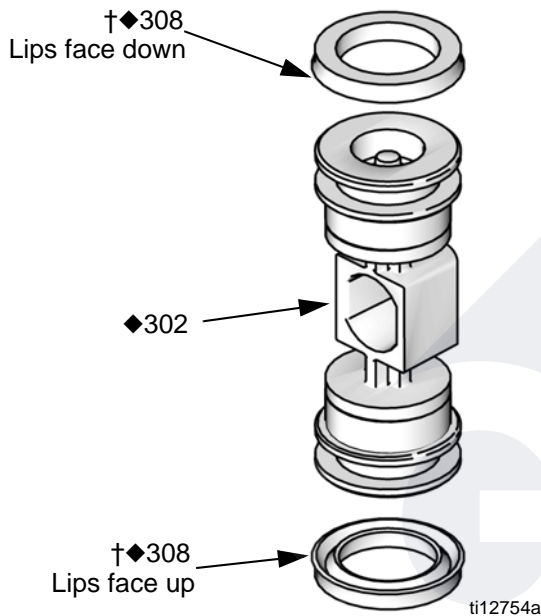

FIG. 13

3. See FIG. 12. Lubricate both ends of the piston (302♦) and install it in the housing.
4. Lubricate and install the detent assembly (303♦) into the piston.
5. Lubricate new o-rings (306†⊗♦) and install on the end caps (307⊗). Install the end caps into the housing.
6. Install a snap ring (310♦⊗) on each end to hold end caps in place.

7. Install the spring (311♦). Lubricate and install the pneumatic valve cup (312♦), see FIG. 14. Align the small round magnet with the pneumatic inlet.
8. Install the valve plate (305♦). Tighten the screws (309†♦) to hold it in place.

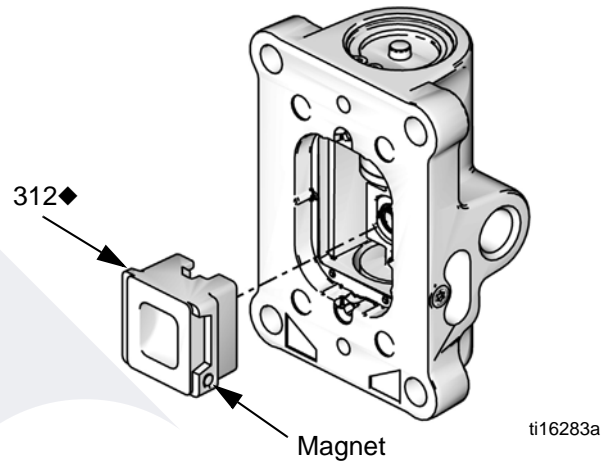

FIG. 14

9. Perform steps 5 and 6 under **Replace Complete Pneumatic Valve**, page 22.

Replace Pilot Valves

1. Stop the pump. Follow the **Pressure Relief Procedure**, page 13.
2. Disconnect the pneumatic line to the motor.
3. Loosen the screw (16) and remove the tie rod shield (15).

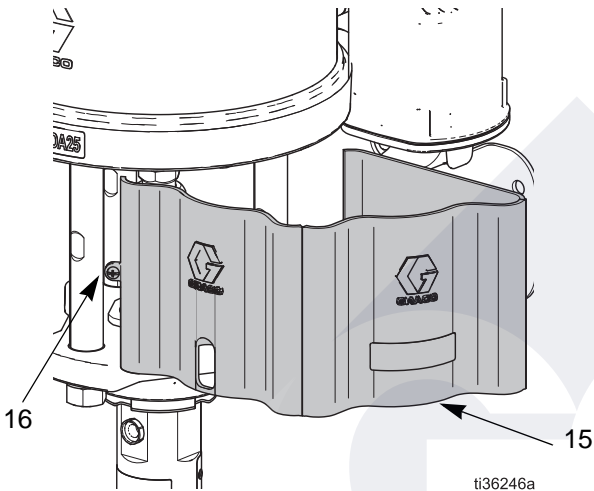

FIG. 15

4. Slide the drip shield (4) down on the tie rods (3).

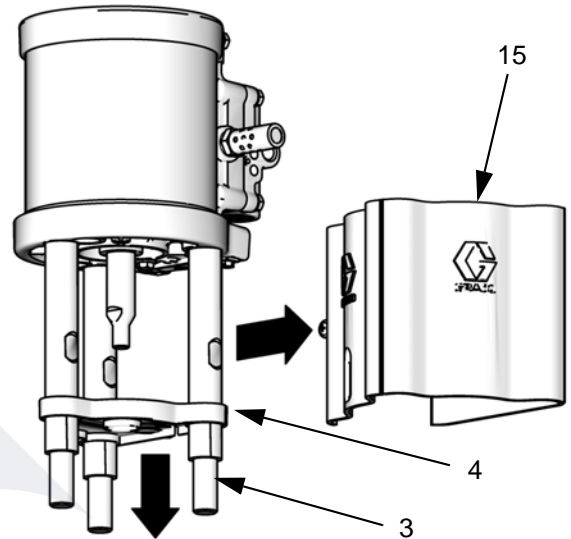

FIG. 16

5. Use a 10 mm socket wrench to remove the old pilot valves (219) from the top (213) and bottom (201) covers. See the figure on page 34.
6. Lubricate and install the new pilot valves (219). Torque to 95-105 in-lb (11-12 N•m).
7. Slide the drip shield (4) to the top of the tie rods (3) and replace the tie rod shield (15).
8. Reconnect the pneumatic line to the motor.

Repair Pneumatic Motor

NOTE: Pneumatic Motor Seal Kits are available. See **Pneumatic Motor Parts List**, page 37, for the correct kit for your motor. For best results, use all parts in the kit.

Disconnect the Pneumatic Motor

1. Flush the pump, if possible. (See package manual.) Follow the **Pressure Relief Procedure**, page 13.
2. Disconnect the pneumatic and fluid hoses, and the ground wire.
3. Loosen the screw (16) and remove the tie rod shield (15). The drip shield (4) may slide down the tie rods once the rod shield is removed. (See FIG. 16.)

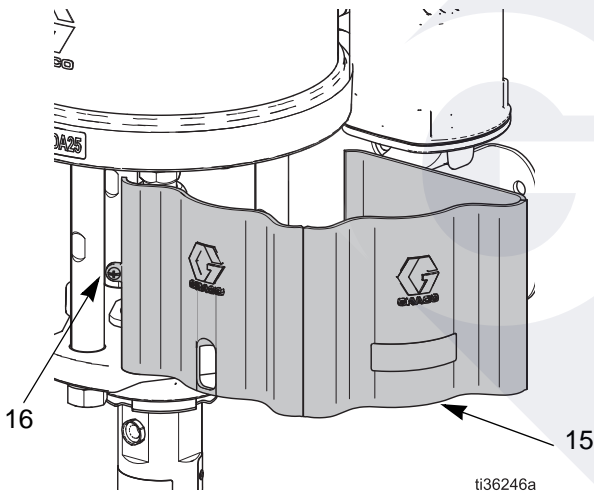

FIG. 17

4. Hold the drip shield (4) out of the way if it is blocking the pneumatic motor plunger (206). Hold the flats of the pneumatic motor plunger (206) with a wrench. Use another wrench to loosen the coupler nut (11).

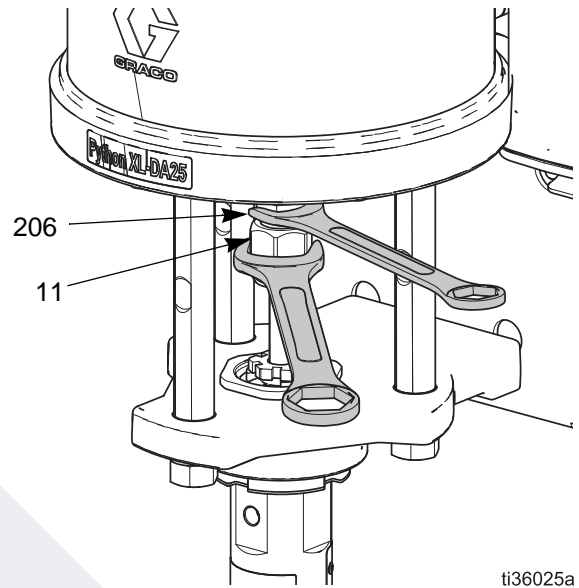

FIG. 18

5. Remove the tie rod nuts (8).
6. Use a socket wrench to remove the mounting screws (14).

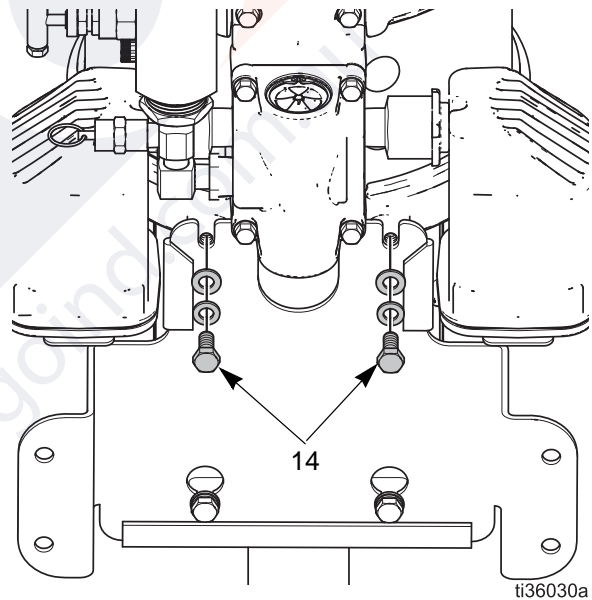
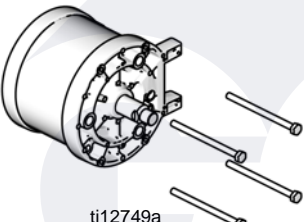
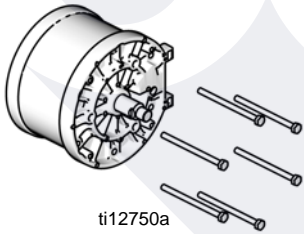

FIG. 19

7. Lift up on the pneumatic motor to remove it. The tie rods (3) and drip shield (4) will remain attached.

Disassemble the Pneumatic Motor

1. Use a 10 mm socket wrench to remove the four screws (218), and remove the pneumatic valve (217) and gasket (216).
2. Remove the mufflers (18).
3. Remove the four screws (218), and remove the manifold (215) and two gaskets (214).
4. Use a 10 mm socket wrench to remove the pilot valves (219), and the top and bottom covers (213 and 201).
5. Remove the 17 mm tie bolts (210). The number of bolts depends on your configuration.

Configuration	
PCI-0600-xxx-xxx-xx-x-x	 <p>ti12749a</p>
PCI-0750-xxx-xxx-xx-x-x	 <p>ti12750a</p>

6. Remove the top cover (213) and the o-ring (209).
7. Remove the shield (212) from around the cylinder (211), and remove the cylinder.
8. Slide the piston assembly straight up off the bottom cover (201).

NOTE: There is no need to take apart the piston assembly. If any part is worn or damaged, the entire assembly should be replaced.

9. Remove the o-ring (208) from around the piston (205).
10. Remove the retaining ring (204), u-cup seals (203), and the o-ring (209) from the bottom cover (201).

Reassemble the Pneumatic Motor

NOTE: For easier reassembly, start with the top cover (213) turned over on the workbench and assemble the pneumatic motor upside-down.

1. Lubricate and install the o-ring (209) on the top cover (213).
2. Install the upper bumper (228) on the top cover.
3. Lubricate the inside of the cylinder (211). Lower the cylinder onto the top cover (213).
4. Lubricate and install the o-ring (208) around the piston (205).
5. Slide the piston assembly down onto the cylinder (211). Be sure the o-ring (208) stays in place.
6. Install the shield (212) around the cylinder (211) and in the groove on the top cover (213).
7. Lubricate and install the new u-cup seal in the bottom of the bearing (202) in the bottom cover (201). The u-cup must face up and the flange face down. See FIG. 20.

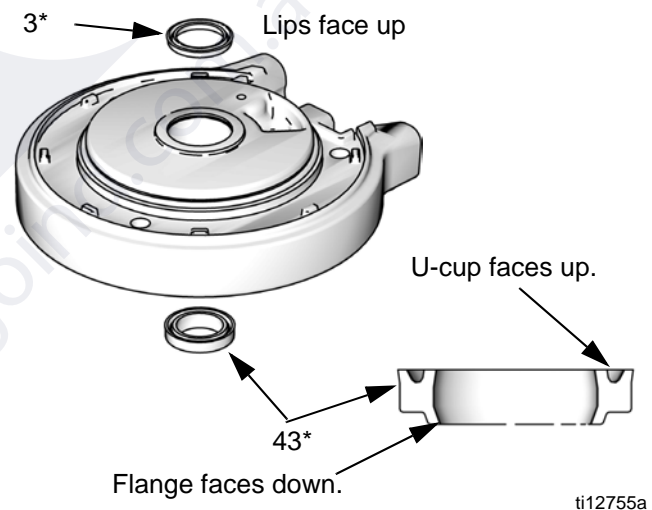

ti12755a

FIG. 20

8. Lubricate and install the new u-cup seal (203) in the top of the bearing. Lips must face up.
9. Lubricate and install the o-ring (209) in the bottom cover (201).
10. Install the piston bumper (228) on the bottom cover (201).

- Carefully place the bottom cover (201) on the cylinder (211), sliding the rod (206) through the bearing (202). The manifold surfaces of the top and bottom covers must align. Be sure the shield (212) is in the groove on both the top and bottom covers.

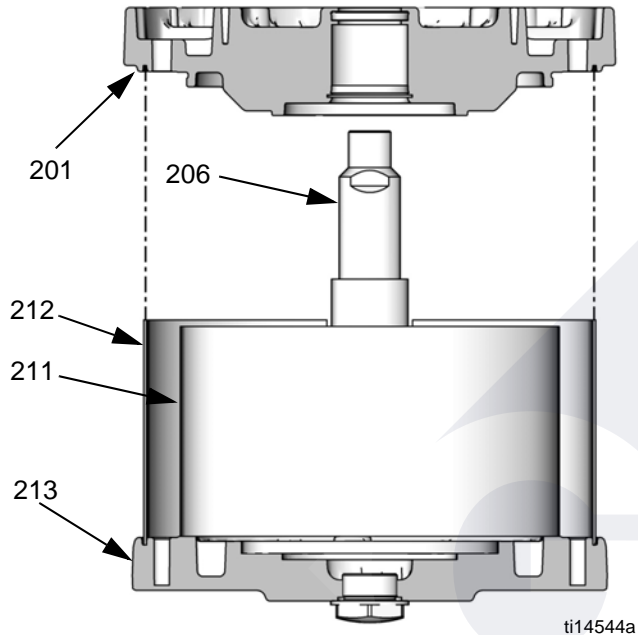

FIG. 21

- Install the tie bolts (210) hand tight.
- Install two gaskets (214) on the manifold (215), and install the manifold. Torque bolts to 95-105 in-lb (11-12 N•m). (The manifold is reversible for ease of placement of the muffler or the remote exhaust.)
- Align the pneumatic valve gasket (216) on the manifold (215), then attach the pneumatic valve (217).
- Tighten the bolts (210) halfway. Work in a criss-cross pattern while tightening the tie bolts. Check that the shield remains in the grooves on both covers. Continue tightening the bolts in pattern and torque to 25-30 ft-lb (34-40 N•m).
- Lubricate and install the pilot valves (219) in the top and bottom covers. Torque to 5-105 in-lb (11-12 N•m).
- Reinstall the mufflers (18).
- See **Reconnect the Pneumatic Motor** on page 28.

Reconnect the Pneumatic Motor

- Replace the motor on the mounting bracket (2).
- Screw the tie rods (3) into the motor, with the top hex nuts (4) attached. Torque the tie rods to 5-10 ft-lb (7-13 N•m).

NOTE: Always tighten the tie rods (3) before tightening the top hex nuts (4).

- Tighten the top hex nuts (4) to secure the mounting bracket (2).
- Slide the pump with the adapter plate (6) attached onto the tie rods (3).
- Install the tie rod nuts (8). Torque to 100 in-lb (11 N•m).
- Align the hole in the fluid plunger (109) with the hole in the pneumatic motor plunger (206).
- Slide the drip shield (4) to the top of the tie rods (3) and replace the tie rod shield (15).
- Reconnect the pneumatic and fluid hoses, and the ground wire.

Parts

Python XL-DA25 Pneumatic Pump

PCI-0750-050-075-XC-2-0 shown

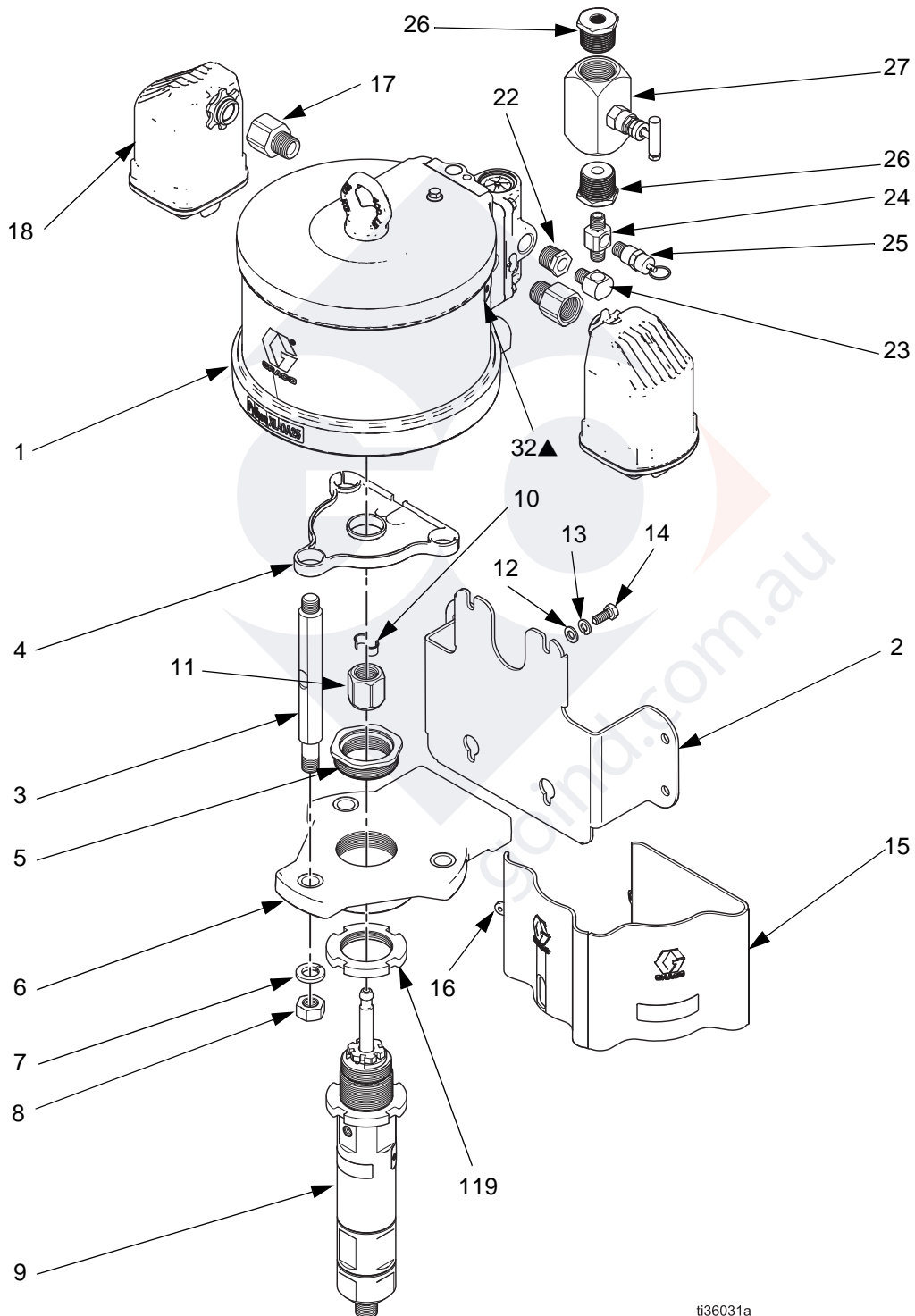

t136031a

Python XL-DA25 Pump Parts List

Ref.	Part	Description	Qty
1	B33007	Pneumatic motor, 6.0 in.; PCI-0600-xxx-xxx-xx-2-x	1
	B33008	Pneumatic motor, 7.5 in.; PCI-0750-xxx-xxx-xx-2-x	1
2	B33100	Wall bracket	1
3	B33101	Motor tie rod	3
4	15V028	Drip shield	1
5	17Y022	Lower adapter nut	1
6	B33102	Pump lower adapter; PCI-xxxx-050-075-xx-2-x PCI-xxxx-075-113-xx-2-x	1
	B33111	Pump lower adapter; PCI-xxxx-100-138-xx-2-x	1
7	--	Lock washer, 5/8 in.; stainless steel; (included with ref. 3)	3
8	--	Hex nut; (included with ref. 3)	3
9	See Pump Lower Mod- els , pg 38	Pump lower	1
10	B33196	Coupling collar; (pack of 10) PCI-xxxx-050-075-xx-2-x	2
	B33103	Coupling collar; (pack of 10) PCI-xxxx-075-113-xx-2-x PCI-xxxx-100-138-xx-2-x	2
11	17Y023	Coupling nut; (pack of 10) PCI-xxxx-050-075-xx-2-x	1
	B33104	Coupling nut; (pack of 10) PCI-xxxx-075-113-xx-2-x PCI-xxxx-100-138-xx-2-x	1
12	--	Flat washer; (included with ref. 2)	4
13	--	Spring lock washer; (included with ref. 2)	4
14	--	Hex head screw; (included with ref. 2)	4
15	B33105	Shield	1
16	--	Screw, M4-.7, 10 mm; stainless steel; (included with ref. 15)	1
17	15U426	Reducing bushing, 3/4 in. nptf - 1/2 in. nptm; (pack of 1)	2
18	24D642	Muffler, 1050 AODD; ice resistant; (pack of 1)	2
22	B33106	Bushing, 1/2 in. x 1/4 in. npt, mf,	1
23	B33107	Elbow fitting, 1/4 in. nptf x 1/4 in. nptm	1
24	B33108	Tee fitting, 1/4 in. nptm-nptf-nptm	1

Ref.	Part	Description	Qty
25	B33109	Safety valve, 110 PSI	1
26	B33110	Pipe bushing fitting, 1 in. x 1/4 in. npt; (pack of 1)	2
27	131295	Needle valve	1
32▲	15W719	Warning Safety Label	1
119	--	Jam nut; included with Ref. 9	1

▲ Replacement Danger and Warning labels, tags, and cards are available at no cost.

Pump Lower

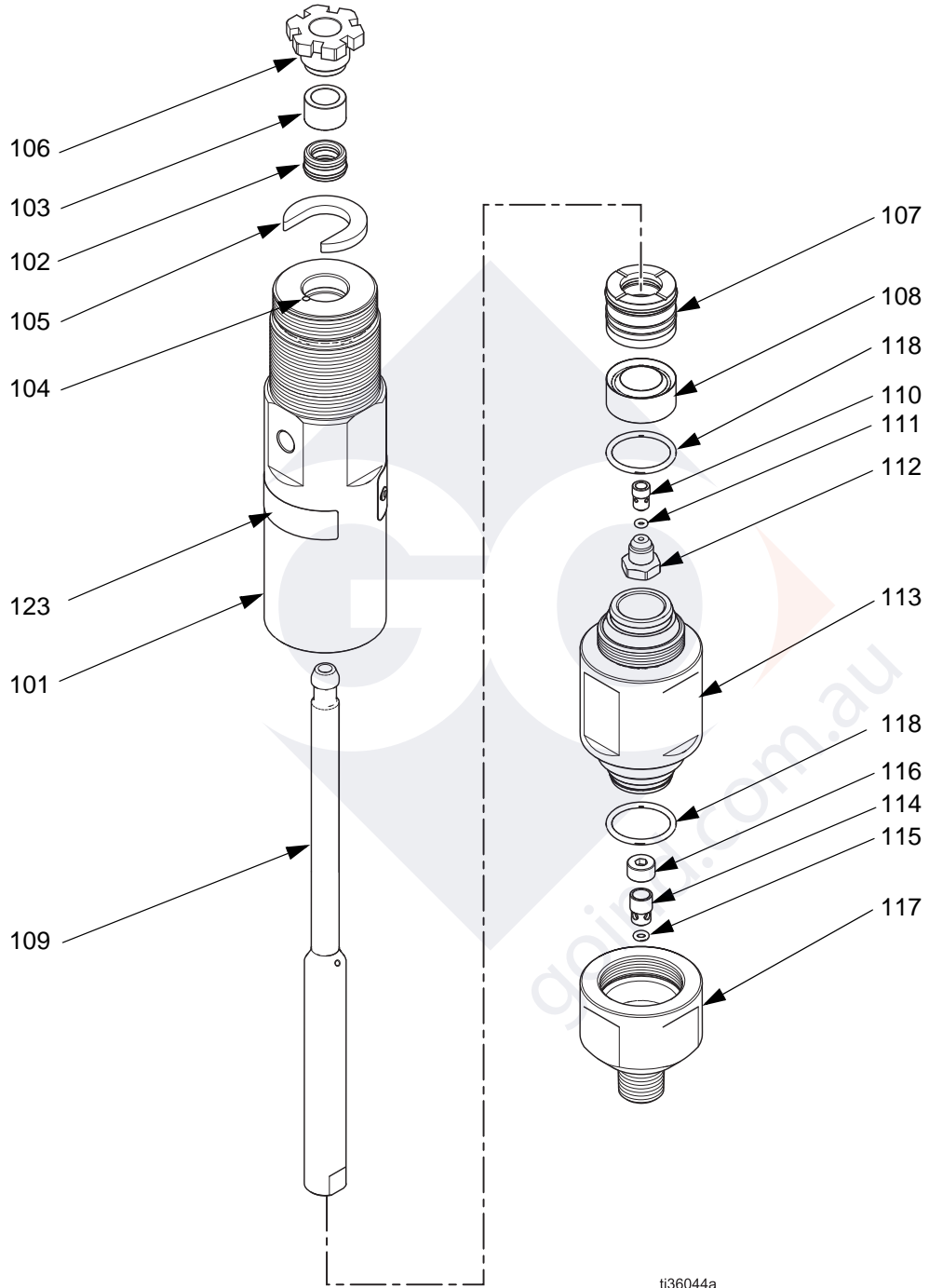

ti36044a

Pump Lower Parts List

Ref.	Description	PCI-xxxx-050-075-xx-2-x 1/2 in. Part numbers	PCI-xxxx-075-113-xx-2-x 3/4 in. Part numbers	PCI-xxxx-100-138-xx-2-x 1 in. Part numbers	Qty
101	Fluid cylinder	B33173	B33138	B33139	1
102	Primary seal stack	See table below			1
103	Primary bearing	B33174	B33136	B33137	1
104	Pellet	(included with ref. 101)			1
105	Packing nut shim	B33175	B33134	B33135	1
106	Packing nut	B33176	B33132	B33133	1
107	Secondary seal stack	See table below			1
108	Secondary bearing	B33177	B33130	B33131	1
109	Fluid plunger	B33178	B33128	B33129	1
110	Plunger poppet	B33179	B33126	B33127	1
111	Plunger poppet o-ring	See table below			1
112	Check seat	B33180	B33124	B33125	1
113	Lower fluid cylinder	B33181	B33122	B33123	1
114	Cylinder poppet	B33182	B33120	B33121	1
115	Cylinder poppet o-ring	See table below			1
116	Check retainer	B33183	B33118	B33119	1
117	Cylinder cap	B33184	B33116	B33117	1
118	O-ring packing; (pack of 10)	B33185	B33114	B33115	2
119	Jam nut (shown on pg 30)	B33186	B33112	B33113	1
123▲	Warning safety label	17G320			1

▲ Replacement Danger and Warning labels, tags, and cards are available at no cost.

Ref.	Description	Seal Material	1/2 in.	3/4 in.	1 in.
102	Primary Seal Stack	C HNBR	B33187	B33140	B33152
		D FFKM	B33188	B33141	B33153
		E TFE/P	B33189	B33142	B33154
107	Secondary Seal Stack	C HNBR	B33190	B33143	B33155
		D FFKM	B33191	B33144	B33156
		E TFE/P	B33192	B33145	B33157
111	Plunger Poppet O-ring	C HNBR	B33193	B33146	B33158
		D FFKM	B33194	B33147	B33159
		E TFE/P	B33195	B33148	B33160
115	Cylinder Poppet O-ring	C HNBR	B33146	B33149	B33161
		D FFKM	B33147	B33150	B33162
		E TFE/P	B33148	B33151	B33163

Pneumatic Motor Parts

PCI-0600, 6.0 in. (152.4 mm); PCI-0750, 7.5 in. (190.5 mm), shown

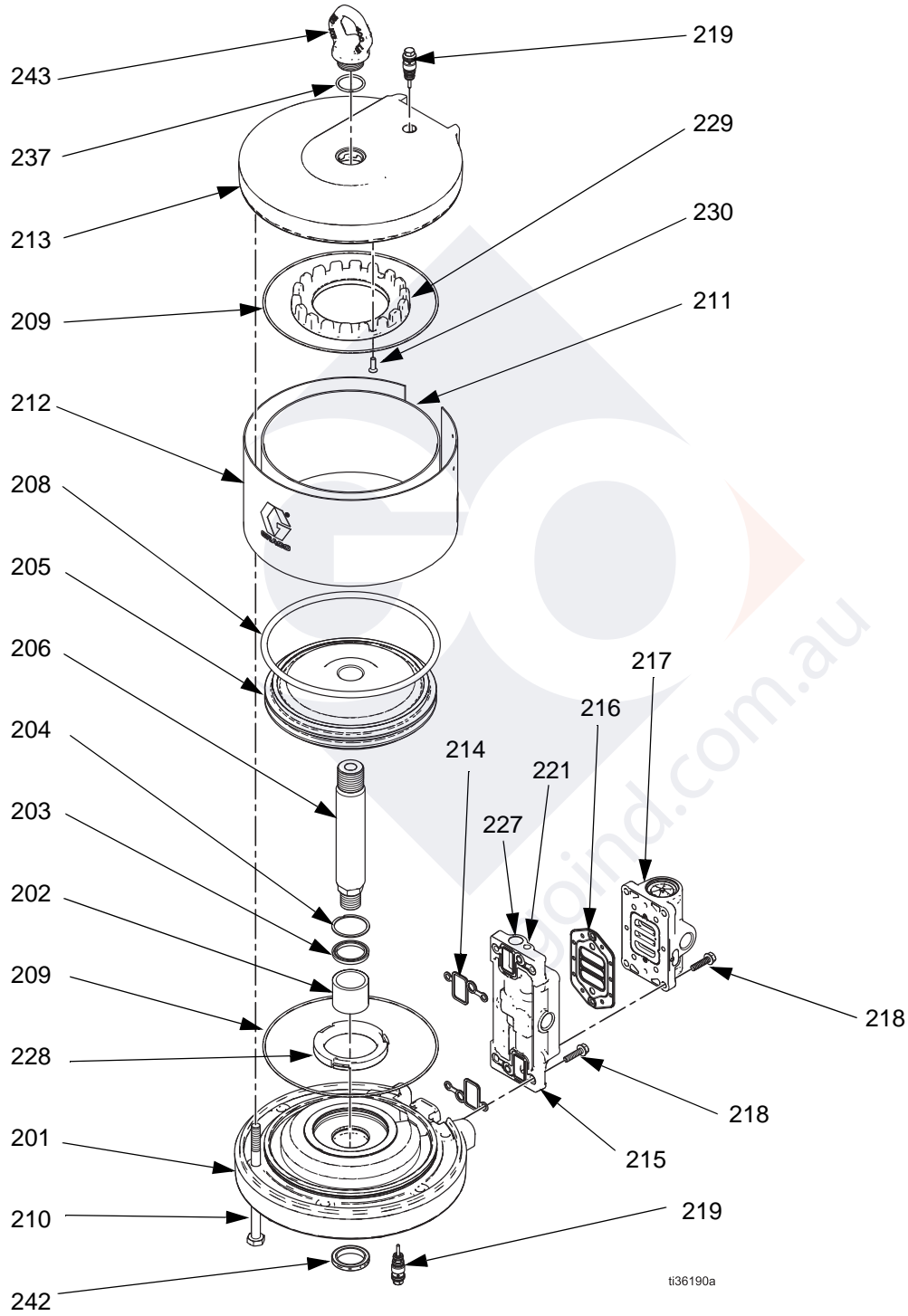

ti36190a

‡ These items are only available in Pneumatic Motor Kits B32251 and B32770

Pneumatic Motor Parts List

Part number shown:

B33007 (PCI-0600): 6.0 in. (152.4 mm)

B33008 (PCI-0750): 7.5 in. (190.5 mm)

Ref.	Part	Description	Qty
201	B33171	Lower cover; PCI-0600	1
	B33172	Lower cover; PCI-0750	1
202	--	Bearing; (included with ref. 201)	1
203✓★	--	U-cup packing	1
204✓★	--	Retainer ring	1
205	24A550	Motor piston; PCI-0600	1
	16G515	Motor piston; PCI-0750	1
206	--	Piston Rod; (included with ref. 205)	1
208✓★	--	Packing o-ring; (included with ref. 205)	1
209✓★	--	End cap o-ring	2
210	B33169	Hex cap screw; PCI-0600	4
	B33170	Hex cap screw; PCI-0750	6
211	15M672	Motor cylinder; PCI-0600	1
	16A516	Motor cylinder; PCI-0750	1
212▲	B33167	Bolt cover; PCI-0600 (includes English warning label)	1
	B33168	Bolt cover; PCI-0750 (includes English warning label)	1
213	B33165	Upper cover; PCI-0600	1
	B33166	Upper cover; PCI-0750	1

Ref.	Part	Description	Qty
214✓★	--	Manifold gasket; (included with ref. 215, 24A580)	2
215	24A580	Motor manifold	1
216✓★	17F429	Pneumatic valve gasket; (included with ref. 215, 24A580)	1
217	B33164	Pneumatic valve	1
218	--	Screw; M6; (included with ref. 215, 24A580)	8
219	24A366	Pilot valve	2
221	--	Ball; (included with ref. 215, 24A580)	2
227	--	Expansion plug; (included with ref. 215, 24A580)	2
228	24A914	Bumper; PCI-0600	1
	24A915	Bumper; PCI-0750	1
229	--	Upper bumper; (included with ref. 228, 24A915)	1
230	--	Screw; M5; (included with ref. 228, 24A915)	3
237	--	O-ring packing; (included with ref. 243)	1
242✓★	--	Rod seal	1
243	24E991	Hook	1

▲ Replacement Danger and Warning labels, tags, and cards are available at no cost.

✓ Included in 6.0 in. Pneumatic Motor Seal Kit 24A547.

★ Included in 7.5 in. Pneumatic Motor Seal Kit 24A551.

Pneumatic Valve Parts

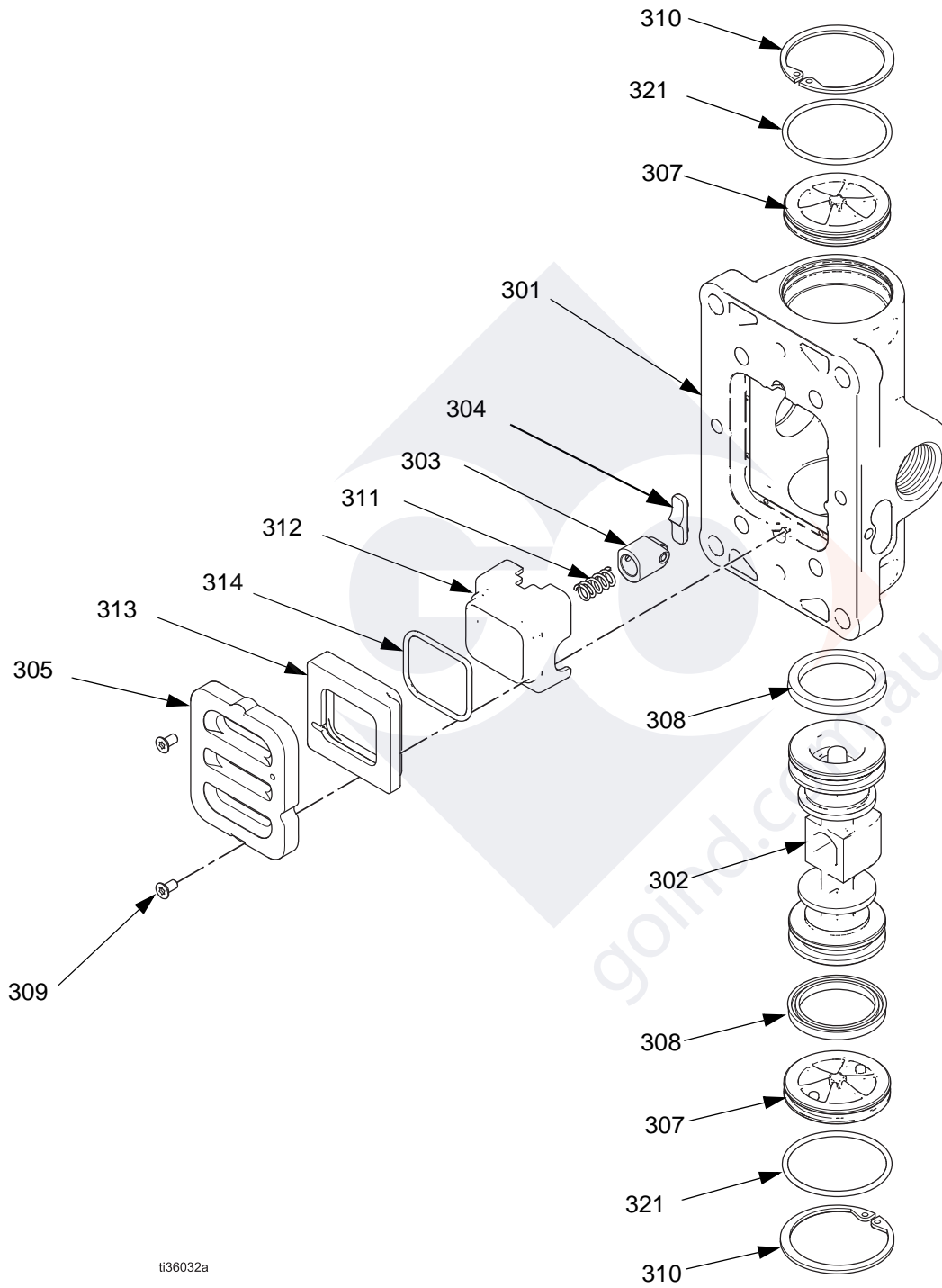

ti36032a

ti16213a

Pneumatic Valve Parts

Complete Pneumatic Valve Replacement Kit B33164

To replace the complete pneumatic valve, order Pneumatic Valve Replacement Kit B33164 (6 in. and 7 in.). The kit includes items 301-312 below, and items 209 and 211 on page 35.

Pneumatic Valve Repair Kits

Pneumatic valve parts are not sold individually. The table below shows possible kit options for each part.

Ref.	Description	Qty.	Pneumatic Valve Repair Kit 24A538	Pneumatic Valve Seal Kit 24A536	Pneumatic Valve End Cap Kit 24A361
301	Housing	1			
302	Pneumatic valve piston	1	✓		
303	Detent piston	1	✓		
304	Detent cam	1	✓		
305	Pneumatic valve plate	1	✓		
307	Cap	2			✓
308	U-cup packing	2	✓	✓	
309	Screw; M3	2	✓	✓	
310	Snap ring	2	✓		✓
311	Detent spring	1	✓		
312	Casting cup	1	✓		
313	Base cup	1	✓		
314	Casting cup gasket	1	✓		
321	O-ring packing	3	✓	✓	✓

Replacement screws (309) are available in a pack of 10. Order Kit 24A359.

Kits and Accessories

Pump Lower Models

Part No.	Configuration Code	Lower Size	Lower Coating	Seal Material
B33010	050-075-XC-2	1/2 in.	Chromex	HNBR
B33011	050-075-XD-2			FFKM
B33012	050-075-XE-2			TFE/P
B33016	075-113-XC-2	3/4 in.	Chromex	HNBR
B33017	075-113-XD-2			FFKM
B33018	075-113-XE-2			TFE/P
B33022	100-138-XC-2	1 in.	Chromex	HNBR
B33023	100-138-XD-2			FFKM
B33024	100-138-XE-2			TFE/P

Additional Kits & Accessories

Part No.	Description
B32045	225-750 PSI Pressure Relief Valve Kit (Adjustable)
B32046	750-1500 PSI Pressure Relief Valve Kit (Adjustable)
B32047	1500-2250 PSI Pressure Relief Valve Kit (Adjustable)
B32048	2250-3000 PSI Pressure Relief Valve Kit (Adjustable)
B32049	3000-4000 PSI Pressure Relief Valve Kit (Adjustable)
B32050	4000-5000 PSI Pressure Relief Valve Kit (Adjustable)
B32051	5000-6000 PSI Pressure Relief Valve Kit (Adjustable)
HIP10RV	1000-10,000 PSI Pressure Relief Valve Kit (Adjustable)
HIP20RV	10,001-20,000 PSI Pressure Relief Valve Kit (Adjustable)
B32088	SST Calibration Column Kit
B32089	SST Manifold Assembly Kit
B32157	316 SST Ball Valve Kit, 3/4 in. NPT(F)
B32158	Fluid Filter 6000 PSI
B32159	Fluid Filter 10000 PSI
B32162	1/4 in. NPT(F) X 1/4 in. NPT(F) Check Kit; 10,000 PSI
237212	Pneumatic Lubricator

AFLAS Air Motor Upgrade Kits

Part No.	Description
B33070*	6.0" AFLAS air motor upgrade
B33071*	7.5" AFLAS air motor upgrade

* Includes ref. 204, 207, 308, and 311

Dimensions

Python XL-DA25 Pump Dimensions

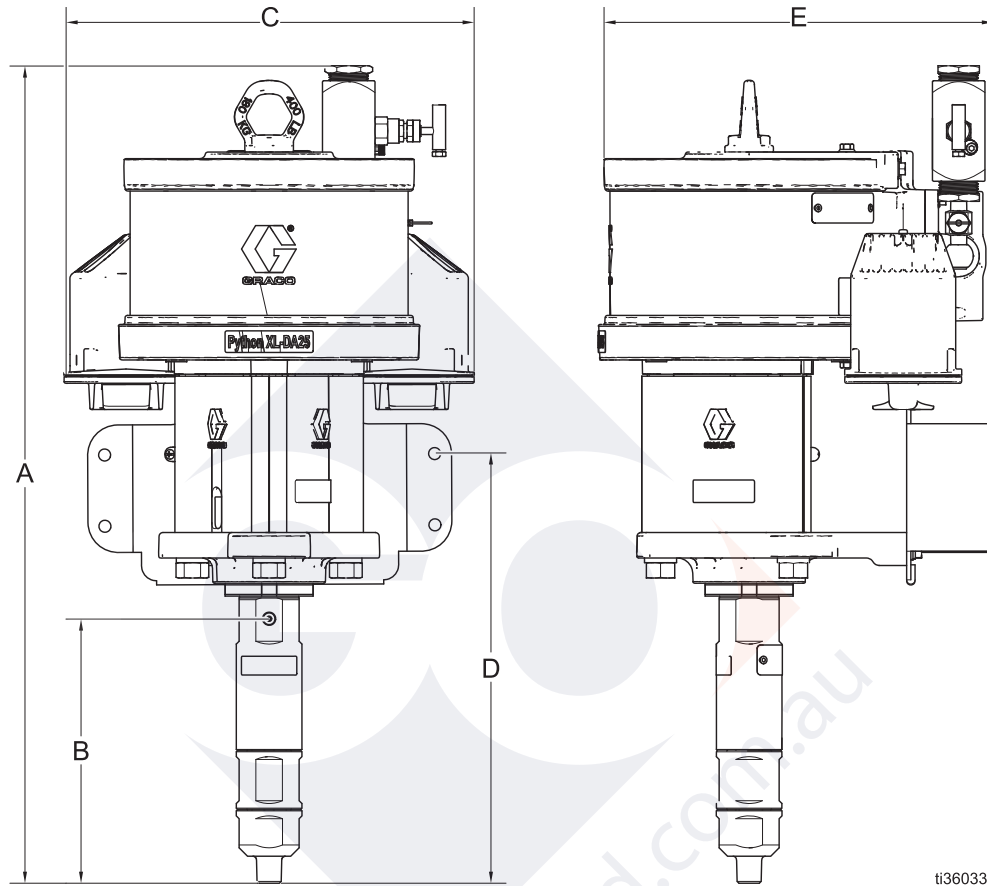

ti36033a

FIG. 22 Python Pump Dimensions

Size	A	B	C	D	E
600	24.0 in. (61.0 cm)	14.5 in. (36.8 cm)	16.75 in. (42.5 cm)	17.75 in. (45.1 cm)	8.0 in. (20.3 cm)
750	24.0 in. (61.0 cm)	14.5 in. (36.8 cm)	16.75 in. (42.5 cm)	17.75 in. (45.1 cm)	8.0 in. (20.3 cm)

Wall Bracket Mounting Hole Diagram

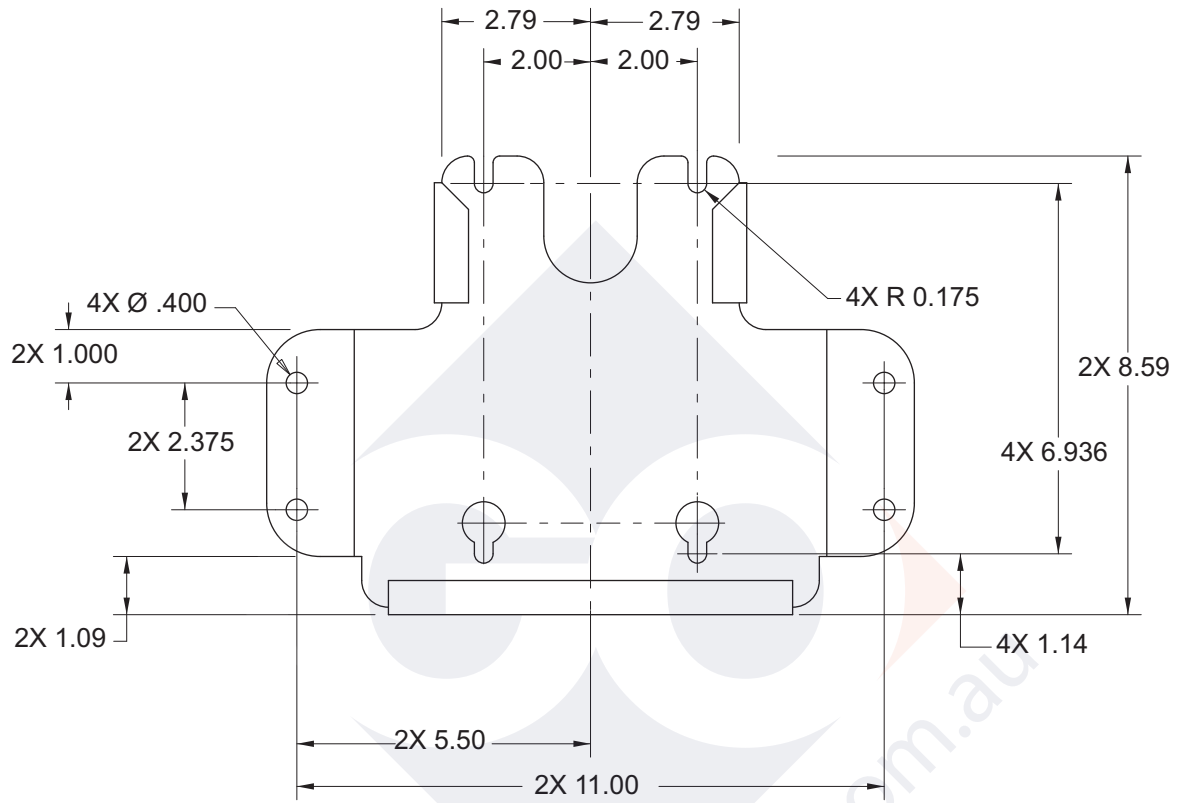

Pneumatic Mounting Hole Diagrams

PCI-0600 (6 in. motor)

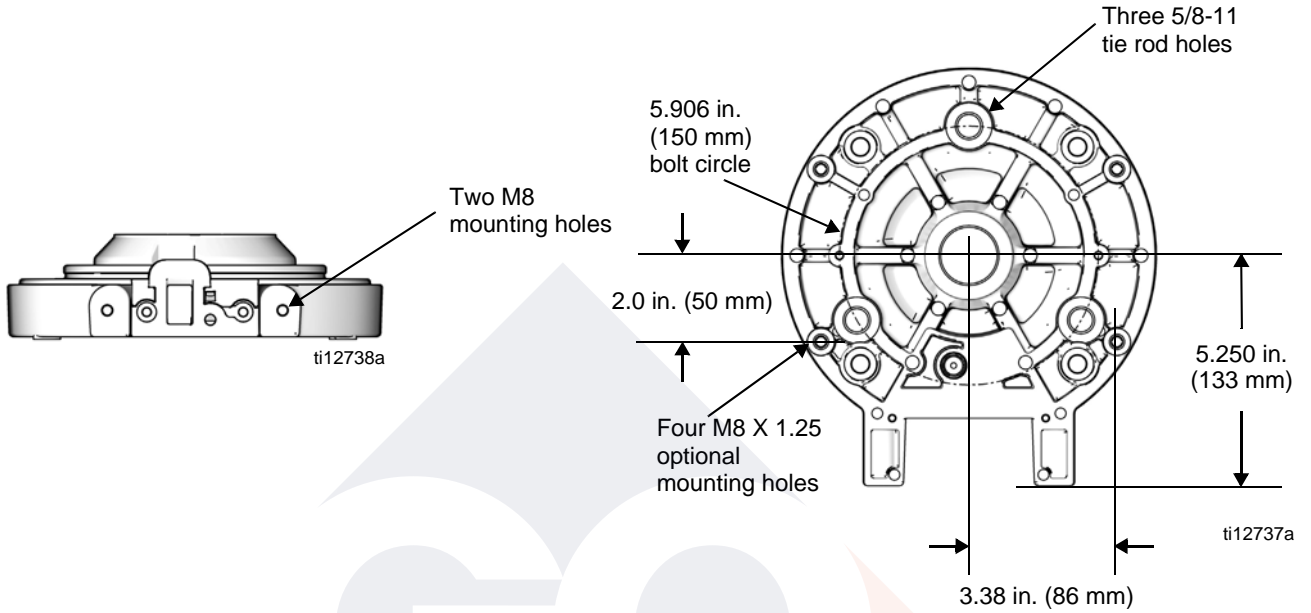

FIG. 23

PCI-0750 (7.5 in. motor)

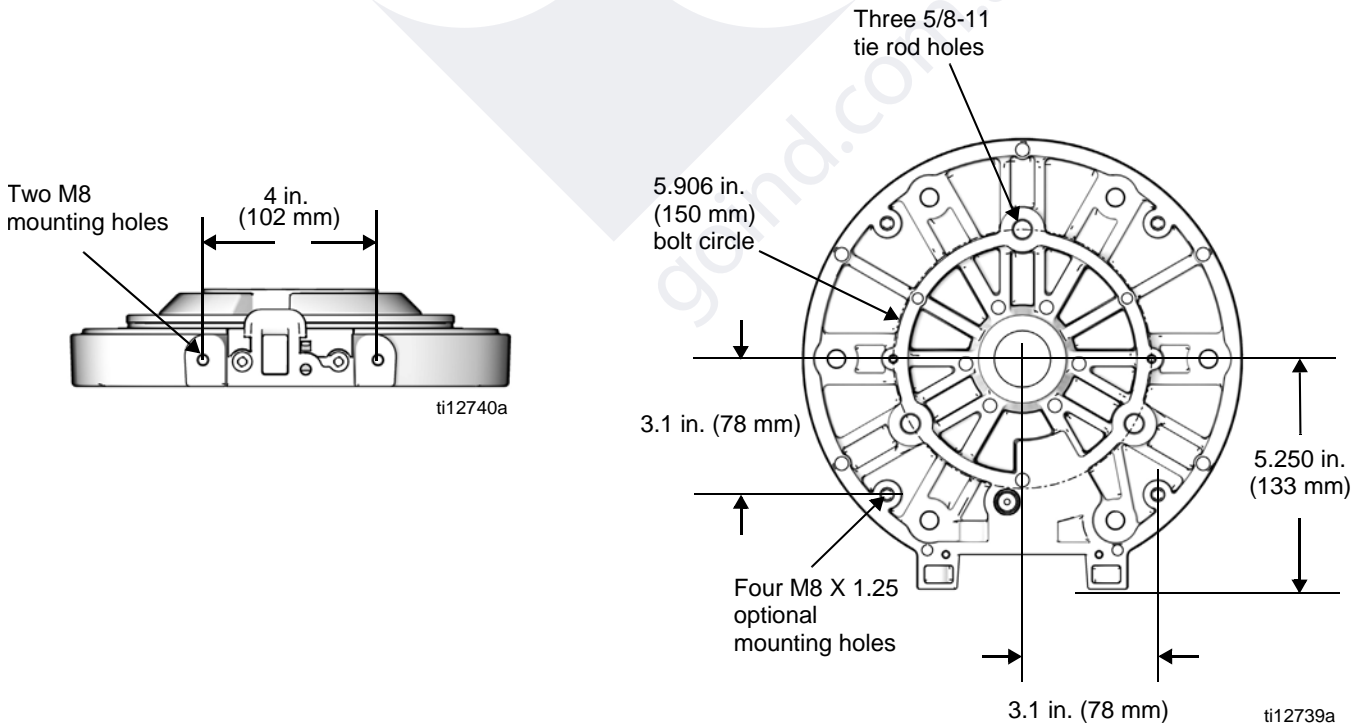

FIG. 24

Performance Charts

6 in. Motors

1/2 in. Plunger (PCI-0600-050)

Inlet Pressure -
 PSI (MPa, Bar)
 A-15 (0.10, 1.0)
 B-25 (0.17, 1.7)
 C-50 (0.34, 3.4)
 D-75 (0.52, 5.2)
 E-100 (0.69, 6.9)

--- Fluid Flow
 -- Air Flow

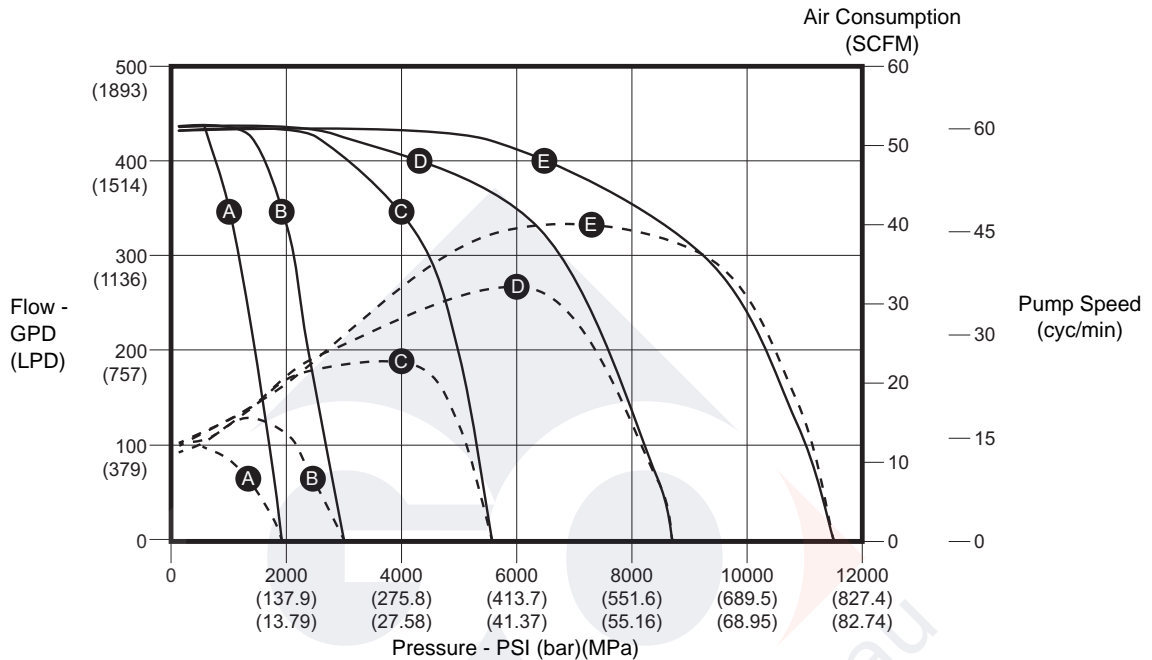

FIG. 25

3/4 in. Plunger (PCI-0600-075)

Inlet Pressure -
 PSI (MPa, Bar)
 A-15 (0.10, 1.0)
 B-25 (0.17, 1.7)
 C-50 (0.34, 3.4)
 D-75 (0.52, 5.2)
 E-100 (0.69, 6.9)

--- Fluid Flow
 -- Air Flow

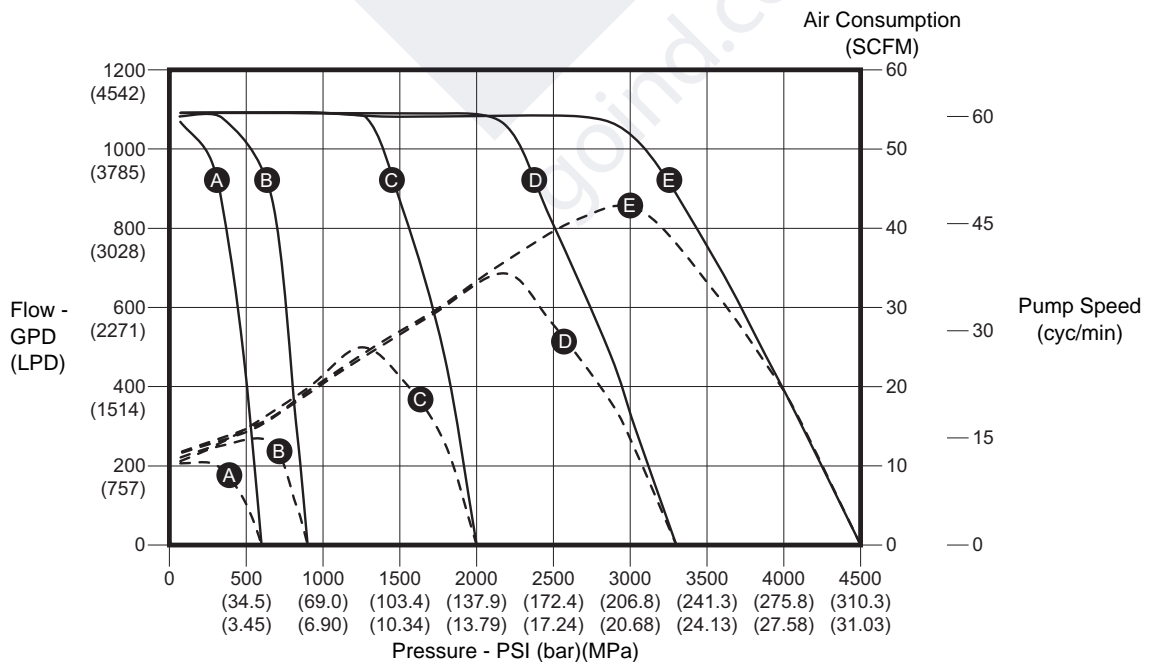

FIG. 26

1 in. Plunger (PCI-0600-100)

Inlet Pressure -
 PSI (MPa, Bar)
 A-15 (0.10, 1.0)
 B-25 (0.17, 1.7)
 C-50 (0.34, 3.4)
 D-75 (0.52, 5.2)
 E-100 (0.69, 6.9)

--- Fluid Flow
 -- Air Flow

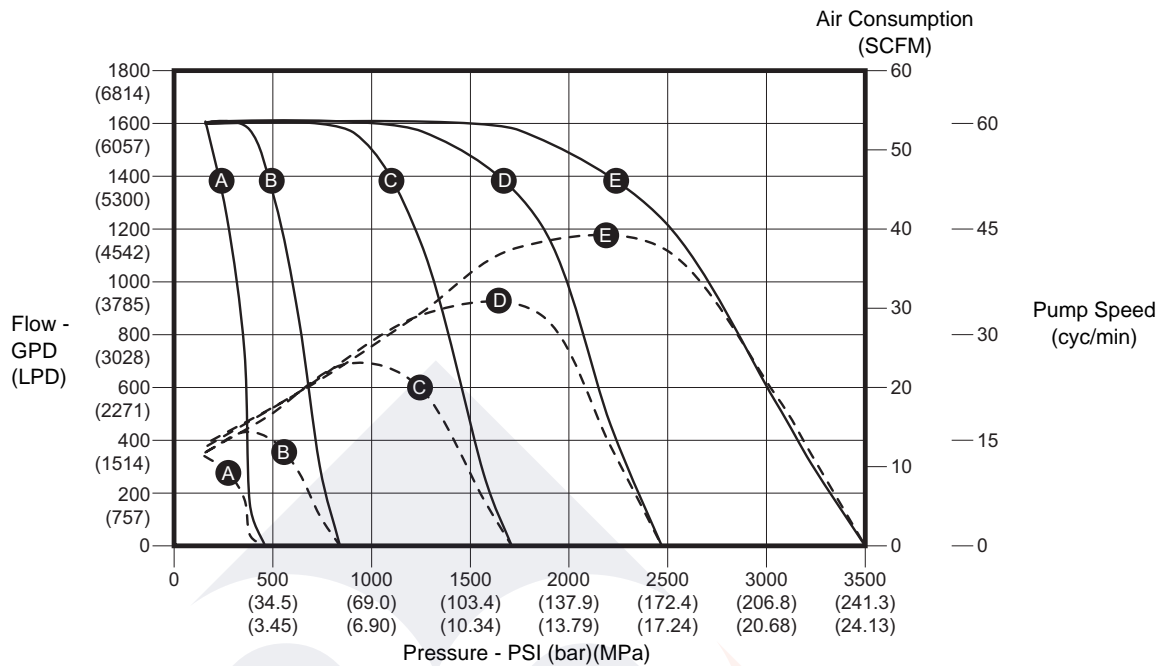

FIG. 27

7.5 in. Motors

3/4 in. Plunger (PCI-0750-075)

Inlet Pressure -
 PSI (MPa, Bar)
 A-15 (0.10, 1.0)
 B-25 (0.17, 1.7)
 C-50 (0.34, 3.4)
 D-75 (0.52, 5.2)
 E-100 (0.69, 6.9)

--- Fluid Flow
 -- Air Flow

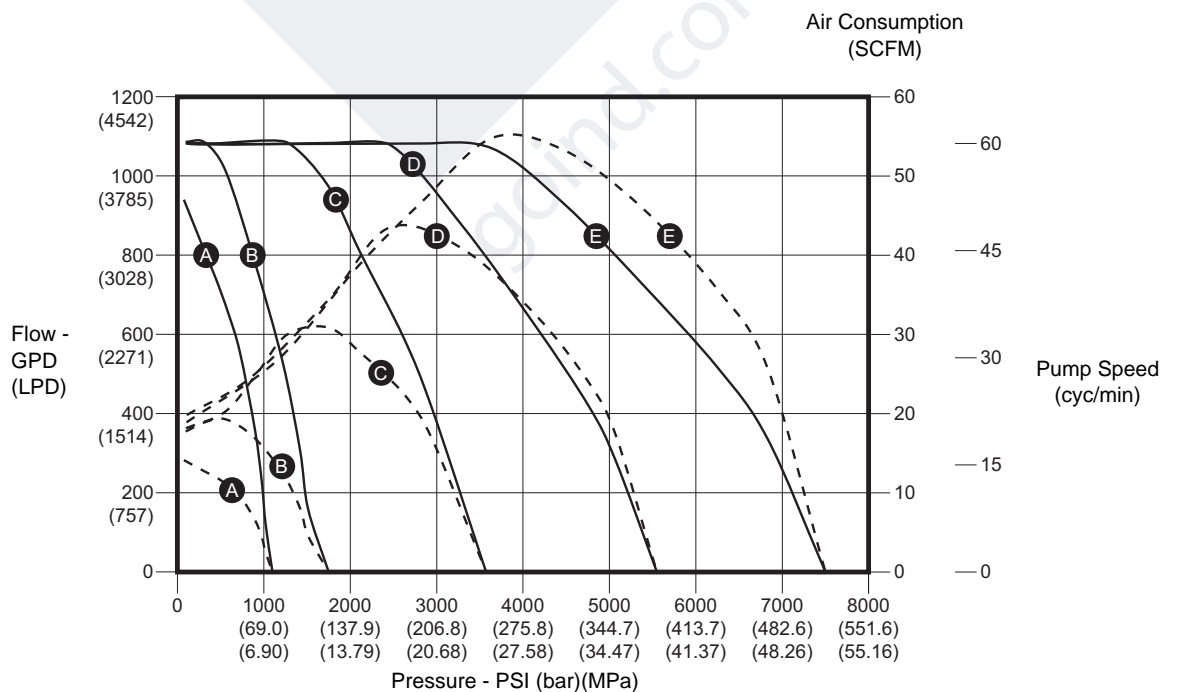

FIG. 28

1 in. Plunger (PCI-0750-100)

Inlet Pressure -
 PSI (MPa, Bar)
 A-15 (0.10, 1.0)
 B-25 (0.17, 1.7)
 C-50 (0.34, 3.4)
 D-75 (0.52, 5.2)
 E-100 (0.69, 6.9)

--- Fluid Flow
 -- Air Flow

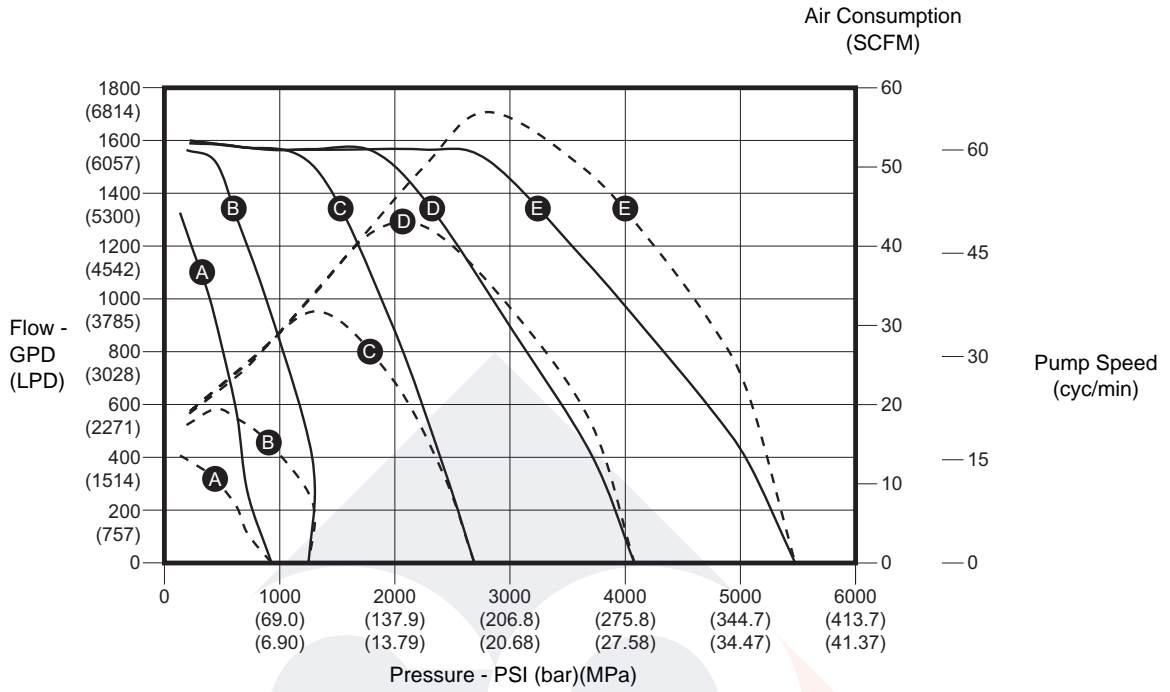

FIG. 29

California Proposition 65

CALIFORNIA RESIDENTS

⚠ WARNING: Cancer and reproductive harm. – www.P65warnings.ca.gov.

Technical Specifications

Python XL-DA25 Chemical Injection Pump		
.....	US	Metric
Maximum pneumatic inlet pressure	See Models on page 3.	
Maximum fluid working pressure	See Models on page 3.	
Maximum cycle rate	60 cpm	
Environmental temperature range	-40°– 176°F	-40°– 80°C
Noise (dBA)		
6.0 in. Pneumatic Motor Sound Power*	80.1 dBA	
6.0 in. Pneumatic Motor Sound Pressure**	70.2 dBA	
7.5 in. Pneumatic Motor Sound Power*	78.8 dBA	
7.5 in. Pneumatic Motor Sound Pressure**	68.9 dBA	
Inlet/Outlet Sizes		
Fluid inlet size (1/2 in. plunger)	1/2 in. npt(m)	
Fluid inlet size (3/4 in. plunger)	3/4 in. npt(m)	
Fluid inlet size (1 in. plunger)	1 in. npt(m)	
Fluid outlet size (1/2 in. plunger)	HiP LF4	
Fluid outlet size (3/4 in. and 1 in. plungers)	1/2 in. npt(f)	
Pneumatic inlet size	1/4 in. npt(f)	
Exhaust fitting size	1/2 in. npt(f)	
Materials of Construction		
Pump/Check Valve Seal Material	See Configuration Number Matrix on page 4 for seal material. All other packing materials are PEEK and PTFE unless otherwise noted.	
Wetted Parts	See Configuration Number Matrix on page 4 for plunger coating. All other materials are 17-4 PH stainless steel unless otherwise noted.	
Weight		
6.0 in. Pneumatic Motor		
0.50 in. lowers (CI-0600-050-075-xx-2-x)	54.5 lbs	24.7 kg
0.75 in. lowers (CI-0600-075-113-xx-2-x)	57.5 lbs	26.1 kg
1.00 in. lowers (CI-0600-100-138-xx-2-x)	60.5 lbs	27.4 kg
7.5 in. Pneumatic Motor		
0.50 in. lowers (CI-0750-050-075-xx-2-x)	59.5 lbs	27.0 kg
0.75 in. lowers (CI-0750-075-113-xx-2-x)	62.5 lbs	28.3 kg
1.00 in. lowers (CI-0750-100-138-xx-2-x)	65.5 lbs	29.7 kg

* Sound Power at 70 psi (0.48 MPa, 4.8 bar), 20 cpm. Sound power measured per ISO-9614-2.

** Sound Pressure was test 3.28 feet (1 m) from equipment.

Graco Standard Warranty

Graco warrants all equipment referenced in this document which is manufactured by Graco and bearing its name to be free from defects in material and workmanship on the date of sale to the original purchaser for use. With the exception of any special, extended, or limited warranty published by Graco, Graco will, for a period of twelve months from the date of sale, repair or replace any part of the equipment determined by Graco to be defective. This warranty applies only when the equipment is installed, operated and maintained in accordance with Graco's written recommendations.

This warranty does not cover, and Graco shall not be liable for general wear and tear, or any malfunction, damage or wear caused by faulty installation, misapplication, abrasion, corrosion, inadequate or improper maintenance, negligence, accident, tampering, or substitution of non-Graco component parts. Nor shall Graco be liable for malfunction, damage or wear caused by the incompatibility of Graco equipment with structures, accessories, equipment or materials not supplied by Graco, or the improper design, manufacture, installation, operation or maintenance of structures, accessories, equipment or materials not supplied by Graco.

This warranty is conditioned upon the prepaid return of the equipment claimed to be defective to an authorized Graco distributor for verification of the claimed defect. If the claimed defect is verified, Graco will repair or replace free of charge any defective parts. The equipment will be returned to the original purchaser transportation prepaid. If inspection of the equipment does not disclose any defect in material or workmanship, repairs will be made at a reasonable charge, which charges may include the costs of parts, labor, and transportation.

THIS WARRANTY IS EXCLUSIVE, AND IS IN LIEU OF ANY OTHER WARRANTIES, EXPRESS OR IMPLIED, INCLUDING BUT NOT LIMITED TO WARRANTY OF MERCHANTABILITY OR WARRANTY OF FITNESS FOR A PARTICULAR PURPOSE.

Graco's sole obligation and buyer's sole remedy for any breach of warranty shall be as set forth above. The buyer agrees that no other remedy (including, but not limited to, incidental or consequential damages for lost profits, lost sales, injury to person or property, or any other incidental or consequential loss) shall be available. Any action for breach of warranty must be brought within two (2) years of the date of sale.

GRACO MAKES NO WARRANTY, AND DISCLAIMS ALL IMPLIED WARRANTIES OF MERCHANTABILITY AND FITNESS FOR A PARTICULAR PURPOSE, IN CONNECTION WITH ACCESSORIES, EQUIPMENT, MATERIALS OR COMPONENTS SOLD BUT NOT MANUFACTURED BY GRACO. These items sold, but not manufactured by Graco (such as electric motors, switches, hose, etc.), are subject to the warranty, if any, of their manufacturer. Graco will provide purchaser with reasonable assistance in making any claim for breach of these warranties.

In no event will Graco be liable for indirect, incidental, special or consequential damages resulting from Graco supplying equipment hereunder, or the furnishing, performance, or use of any products or other goods sold hereto, whether due to a breach of contract, breach of warranty, the negligence of Graco, or otherwise.

Graco Information

For the latest information about Graco products, visit www.graco.com.

For patent information, see www.graco.com/patents.

TO PLACE AN ORDER, contact your Graco distributor or call to identify the nearest distributor.

Phone: 612-623-6921 **or Toll Free:** 1-800-328-0211 **Fax:** 612-378-3505

*All written and visual data contained in this document reflects the latest product information available at the time of publication.
Graco reserves the right to make changes at any time without notice.*

Original instructions. This manual contains English. MM 3A6831

Graco Headquarters: Minneapolis

International Offices: Belgium, China, Japan, Korea

GRACO INC. AND SUBSIDIARIES • P.O. BOX 1441 • MINNEAPOLIS MN 55440-1441 • USA
Copyright 2019, Graco Inc. All Graco manufacturing locations are registered to ISO 9001.

www.graco.com

Revision H, June 2020