

Python[®] XL-DA Pump

3A5938F

(For Applications Requiring ATEX Approval)

EN

**Pneumatic pump for injecting chemicals at well sites. For use with compressed air only.
For professional use only.**

See page 3 for model information, including maximum working pressures.



Important Safety Instructions

Read all warnings and instructions in this manual.
Save all instructions.

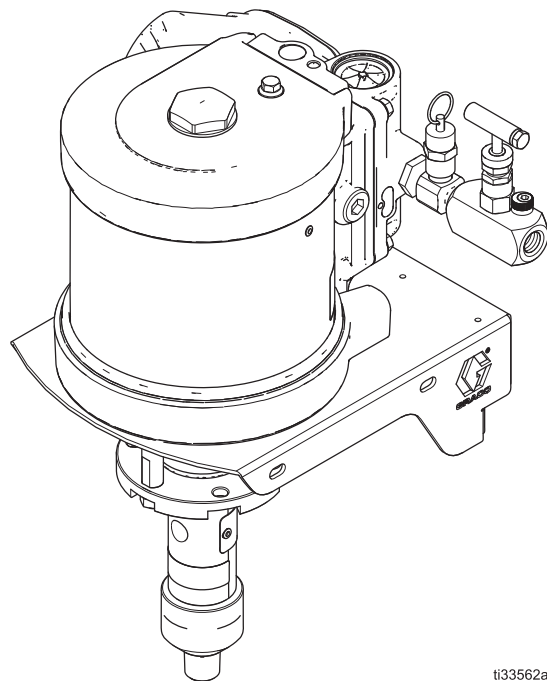

ti33562a

CE  II 2 G Ex h IIA T5 Gb

Contents

Models	3	Technical Data	49
Configuration Number Matrix	5	** Sound Pressure was test 3.28 feet (1 m) from equipment.	49
Pump Configuration	5	California Proposition 65	49
Lower Configuration	5	Graco Standard Warranty	50
Warnings	6		
Installation	8		
Grounding	8		
Required Accessories	8		
Flush Before Using Equipment	8		
Typical Installation	9		
Mount the Pump and Connect Chemical Supply	9		
Connect Pneumatic Supply	10		
Route Exhaust to Remote Location	10		
Connect Chemical Outlet	11		
Operation	15		
Pressure Relief Procedure	15		
Flush the Equipment	15		
Prime the Pump	16		
Calibrate Chemical Dosage	16		
Maintenance	17		
Preventive Maintenance Schedule	17		
Tighten Threaded Connections	17		
Tighten Packings	17		
Storage	17		
Troubleshooting	18		
Repair	20		
Pump	20		
Pneumatic Valve	25		
Replace Pilot Valves	27		
Disconnect the Pneumatic Motor	28		
Reconnect the Pneumatic Motor	28		
Repair Pneumatic Motor	29		
Parts	32		
Python XL-DA Pneumatic Pump	32		
Pneumatic Motor Parts	36		
Pneumatic Valve Parts	38		
Kits and Accessories	40		
Dimensions	41		
Python XL-DA Pump Dimensions	41		
Wall Bracket Mounting Hole Diagram	42		
Performance Charts	43		
2.5 in. Motors	43		
3.5 in. Motors	44		
4.5 in. Motors	46		
Air Consumption	48		

Models

Plunger Size	Pneumatic Motor Size	Maximum Working Pressure psi (MPa, bar)	Maximum Pneumatic Inlet Pressure psi (MPa, bar)
3/8 in.	2.5 in.	4,440 (30.6, 306)	100 (0.69, 6.9)
1/2 in.		1,905 (13.1, 131)	
3/4 in.		840 (5.8, 58)	
1/2 in.	3.5 in.	3,750 (25.9, 259)	
3/4 in.		1,650 (11.4, 114)	
1 in.		1,225 (8.4, 84)	
1/2 in.	4.5 in.	6,175 (42.6, 426)	
3/4 in.		2,730 (18.8, 188)	
1 in.		2,025 (14.0, 140)	

NOTE: See the **Configuration Number Matrix**, page 5, to find the plunger and pneumatic motor size for your unit.

Part Number	Configuration Code	Motor Size	Lower Size	Lower Coating	Seal Material
A24200	PCI-0250-038-025-XC-1-A	2.5 in.	3/8 in.	Chromex	HNBR
A24201	PCI-0250-038-025-XD-1-A				FFKM
A24202	PCI-0250-038-025-XE-1-A				TFE/P
A24203	PCI-0250-038-025-CC-1-A			Ceramic	HNBR
A24204	PCI-0250-038-025-CD-1-A				FFKM
A24205	PCI-0250-038-025-CE-1-A				TFE/P
A24206	PCI-0250-050-050-XC-1-A		1/2 in.	Chromex	HNBR
A24207	PCI-0250-050-050-XD-1-A				FFKM
A24208	PCI-0250-050-050-XE-1-A				TFE/P
A24209	PCI-0250-050-050-CC-1-A			Ceramic	HNBR
A24210	PCI-0250-050-050-CD-1-A				FFKM
A24211	PCI-0250-050-050-CE-1-A				TFE/P
A24212	PCI-0250-075-063-XC-1-A		3/4 in.	Chromex	HNBR
A24213	PCI-0250-075-063-XD-1-A				FFKM
A24214	PCI-0250-075-063-XE-1-A				TFE/P
A24215	PCI-0250-075-063-CC-1-A			Ceramic	HNBR
A24216	PCI-0250-075-063-CD-1-A				FFKM
A24217	PCI-0250-075-063-CE-1-A				TFE/P

Models

Part Number	Configuration Code	Motor Size	Lower Size	Lower Coating	Seal Material
A24306	PCI-0350-050-050-XC-1-A	3.5 in.	1/2 in.	Chromex	HNBR
A24307	PCI-0350-050-050-XD-1-A				FFKM
A24308	PCI-0350-050-050-XE-1-A				TFE/P
A24309	PCI-0350-050-050-CC-1-A			Ceramic	HNBR
A24310	PCI-0350-050-050-CD-1-A				FFKM
A24311	PCI-0350-050-050-CE-1-A				TFE/P
A24312	PCI-0350-075-063-XC-1-A		3/4 in.	Chromex	HNBR
A24313	PCI-0350-075-063-XD-1-A				FFKM
A24314	PCI-0350-075-063-XE-1-A				TFE/P
A24315	PCI-0350-075-063-CC-1-A			Ceramic	HNBR
A24316	PCI-0350-075-063-CD-1-A				FFKM
A24317	PCI-0350-075-063-CE-1-A				TFE/P
A24318	PCI-0350-100-088-XC-1-A		1 in.	Chromex	HNBR
A24319	PCI-0350-100-088-XD-1-A				FFKM
A24320	PCI-0350-100-088-XE-1-A				TFE/P
A24321	PCI-0350-100-088-CC-1-A			Ceramic	HNBR
A24322	PCI-0350-100-088-CD-1-A				FFKM
A24323	PCI-0350-100-088-CE-1-A				TFE/P
A24406	PCI-0450-050-050-XC-1-A	4.5 in.	1/2 in.	Chromex	HNBR
A24407	PCI-0450-050-050-XD-1-A				FFKM
A24408	PCI-0450-050-050-XE-1-A				TFE/P
A24409	PCI-0450-050-050-CC-1-A			Ceramic	HNBR
A24410	PCI-0450-050-050-CD-1-A				FFKM
A24411	PCI-0450-050-050-CE-1-A				TFE/P
A24412	PCI-0450-075-063-XC-1-A		3/4 in.	Chromex	HNBR
A24413	PCI-0450-075-063-XD-1-A				FFKM
A24414	PCI-0450-075-063-XE-1-A				TFE/P
A24415	PCI-0450-075-063-CC-1-A			Ceramic	HNBR
A24416	PCI-0450-075-063-CD-1-A				FFKM
A24417	PCI-0450-075-063-CE-1-A				TFE/P
A24418	PCI-0450-100-088-XC-1-A		1 in.	Chromex	HNBR
A24419	PCI-0450-100-088-XD-1-A				FFKM
A24420	PCI-0450-100-088-XE-1-A				TFE/P
A24421	PCI-0450-100-088-CC-1-A			Ceramic	HNBR
A24422	PCI-0450-100-088-CD-1-A				FFKM
A24423	PCI-0450-100-088-CE-1-A				TFE/P

Configuration Number Matrix

Check the identification plate (ID) for the 17-digit Configuration Number of your pump. Use the following matrix to define the components of your pump.

NOTE: Not all combinations are possible.

Sample Configuration Number: PCI-0450-038-025-XC-1-A

PCI	0450	038	025	X	C	1	A
Pneumatic Chemical Injection	Pneumatic Motor Size	Pump Lower Primary Seal Size	Pump Lower Secondary Seal Size	Pump Lower Coating	Seal Material	Pump Stroke Length	Qualifier

Pump Configuration



Pneumatic Motor Size	Pump Lower Primary Seal Size	Pump Lower Secondary Seal Size	Pump Lower Coating	Seal Material	Pump Stroke Length	Qualifier
0250 2 1/2 in.	038 3/8 in. diameter	025 1/4 in. diameter	X Chromex	C HNBR	1 1 inch	0 None
0350 3 1/2 in.	050 1/2 in. diameter	050 1/2 in. diameter	C Ceramic	D FFKM		A ATEX
0450 4 1/2 in.	075 3/4 in. diameter	063 5/8 in. diameter		E TFE/P		
	100 1 in. diameter	088 7/8 in. diameter				

Lower Configuration

Pump Lower Primary Seal Size	Pump Lower Secondary Seal Size	Pump Lower Coating	Seal Material	Pump Stroke Length
038 3/8 in. diameter	025 1/4 in. diameter	X Chromex	C HNBR	1 1 inch
050 1/2 in. diameter	050 1/2 in. diameter	C Ceramic	D FFKM	
075 3/4 in. diameter	063 5/8 in. diameter		E TFE/P	
100 1 in. diameter	088 7/8 in. diameter			

Warnings

The following warnings are for the setup, use, grounding, maintenance, and repair of this equipment. The exclamation point symbol alerts you to a general warning and the hazard symbols refer to procedure-specific risks. When these symbols appear in the body of this manual or on warning labels, refer back to these Warnings. Product-specific hazard symbols and warnings not covered in this section may appear throughout the body of this manual where applicable.

 <h1 style="margin: 0;">WARNING</h1>	
	<p>FIRE AND EXPLOSION HAZARD</p> <p>When flammable fluids are present in the work area be aware that flammable fumes can ignite or explode. To help prevent fire and explosion:</p> <ul style="list-style-type: none"> • Use equipment only in well ventilated area. • Eliminate all ignition sources, such as cigarettes and portable electric lamps. • Ground all equipment in the work area. • Keep work area free of debris, including rags and spilled or open containers of solvent. • Do not plug or unplug power cords or turn lights on or off when flammable fumes are present. • Use only grounded hoses. • Stop operation immediately if static sparking occurs or you feel a shock. Do not use equipment until you identify and correct the problem. • Keep a working fire extinguisher in the work area.
	<p>SKIN INJECTION HAZARD</p> <p>High-pressure fluid from dispensing device, hose leaks, or ruptured components will pierce skin. This may look like just a cut, but it is a serious injury that can result in amputation. Get immediate surgical treatment.</p> <ul style="list-style-type: none"> • Do not put your hand over the fluid outlet. • Do not stop or deflect leaks with your hand, body, glove, or rag. • Follow the Pressure Relief Procedure when you stop dispensing and before cleaning, checking, or servicing equipment. • Tighten all fluid connections before operating the equipment. • Check hoses and couplings daily. Replace worn or damaged parts immediately.
	<p>TOXIC FLUID OR FUMES HAZARD</p> <p>Toxic fluids or fumes can cause serious injury or death if splashed in the eyes or on skin, inhaled, or swallowed.</p> <ul style="list-style-type: none"> • Read Safety Data Sheet (SDS) to know the specific hazards of the fluids you are using. • Store hazardous fluid in approved containers, and dispose of it according to applicable guidelines.

! WARNING



PERSONAL PROTECTIVE EQUIPMENT

Wear appropriate protective equipment when in the work area to help prevent serious injury, including eye injury, hearing loss, inhalation of toxic fumes, and burns. Protective equipment includes but is not limited to:

- Protective eyewear, and hearing protection.
- Respirators, protective clothing, and gloves as recommended by the fluid and solvent manufacturer.





EQUIPMENT MISUSE HAZARD

Misuse can cause death or serious injury.



- Do not operate the unit when fatigued or under the influence of drugs or alcohol.
- Do not exceed the maximum working pressure or temperature rating of the lowest rated system component. See **Technical Data** in all equipment manuals.
- Use fluids and solvents that are compatible with equipment wetted parts. See **Technical Data** in all equipment manuals. Read fluid and solvent manufacturer's warnings. For complete information about your material, request Safety Data Sheet (SDS) from distributor or retailer.
- Turn off all equipment and follow the **Pressure Relief Procedure** when equipment is not in use.
- Check equipment regularly. Repair or replace worn or damaged parts immediately with genuine manufacturer's replacement parts only.
- Do not alter or modify equipment. Alterations or modifications may void agency approvals and create safety hazards.
- Make sure all equipment is rated and approved for the environment in which you are using it.
- Use equipment only for its intended purpose. Call your distributor for information.
- Route hoses and cables away from traffic areas, sharp edges, moving parts, and hot surfaces.
- Do not kink or over bend hoses or use hoses to pull equipment.
- Keep children and animals away from work area.
- Comply with all applicable safety regulations.



Installation

				
<p>To reduce the risk of injury from ejected ice, do not operate the motor without a plumbed exhaust line or muffler installed.</p> <p>Installation must comply with all local codes and regulations.</p>				

Grounding

				
<p>The equipment must be grounded to reduce the risk of static sparking. Static sparking can cause fumes to ignite or explode. Grounding provides an escape wire for the electric current.</p>				

Pump: ground through electrically conductive pneumatic and fluid lines.

Pneumatic and fluid lines: use only electrically conductive lines.

Air compressor: follow manufacturer's recommendations.

Fluid supply container: follow local code.

Required Accessories

Install the following required accessories in the order shown in FIG. 1, using adapters as necessary.

Pneumatic Line

- **Bleed-type master pneumatic valve (D):** required in your system to relieve air trapped between it and the pneumatic motor when the valve is closed.
 - Be sure the valve is easily accessible from the pump and located downstream from the pneumatic regulator.
- **Pump pneumatic regulator (E):** to control pump speed and outlet pressure. Locate it close to the pump.
- **Pneumatic line filter (C):** removes harmful dirt and moisture from compressed air supply.
- **Second bleed-type pneumatic valve (pneumatic shutoff valve) (B):** isolates pneumatic line accessories for servicing. Locate upstream from all other pneumatic line accessories.

Fluid Line

- **Fluid filter (Y-Strainer) (included in G):** with a 60 mesh (250 micron) stainless steel element to filter particles from the fluid before it reaches the pump.
- **Fluid shutoff valve (H):** shuts off fluid flow.
- **Pressure relief valve (J):** overload protection.

Flush Before Using Equipment

The equipment was tested with lightweight oil, which is left in the fluid passages to protect parts. To avoid contaminating your fluid with oil, flush the equipment with a compatible solvent before using the equipment. See **Flush the Equipment**, page 15.

Typical Installation

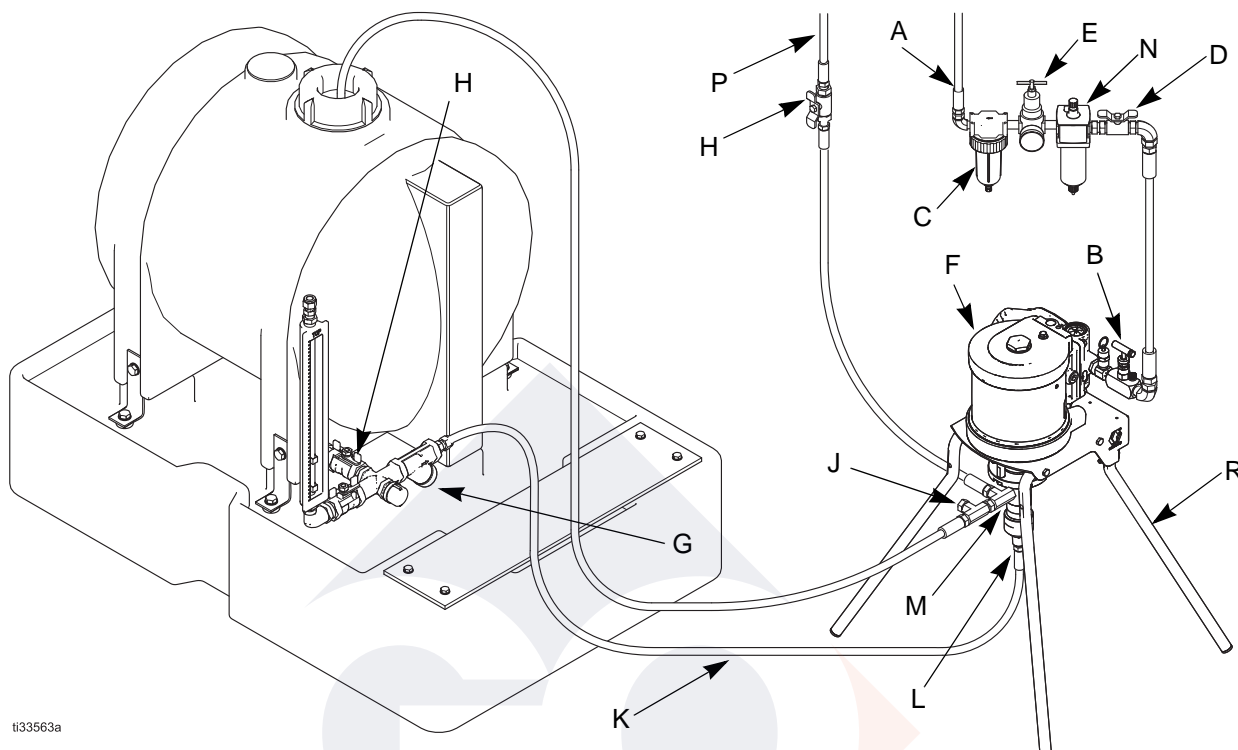

ti33563a

FIG. 1: Typical Installation

FIG. 1 is an example of an installation with a Python XL-DA chemical injection pump. Your installation may differ from what is shown here. (See **Required Accessories**, page 8.) The Python pump (F) and needle valve (B) are the only components in FIG. 1 supplied by Graco. All other components are supplied by customer.

Key:

- A Main Pneumatic Supply Line
- B Pneumatic Needle Valve
- C Pneumatic Filter
- D Bleed-type Master Pneumatic Valve
- E Pneumatic Pressure Regulator
- F Pump
- G Manifold Assembly (includes y-strainer and fluid shutoff valve (H))
- H Fluid Shutoff Valve (inlet & outlet)
- J Fluid Pressure Relief Valve
- K Fluid Inlet Line
- L Inlet Port
- M Outlet Port
- N Pneumatic Lubricator
- P Fluid Outlet Line
- R Stand (optional)

Mount the Pump and Connect Chemical Supply



The pump can be bolted to a wall or skid by the attached bracket.

NOTE: The pump must always be mounted vertically.

If you have an application, or mounting configuration, that requires installation in a manner different than depicted in FIG. 1, please contact your Graco distributor for assistance.

NOTE: A y-strainer (G) or chemical filter is required before the pump inlet. This will keep any debris from the tank from reaching the pump seals. Fluid filters are available from Graco.

1. Mount the pump (F) and connect the fluid inlet line (K).

Connect Pneumatic Supply

1. Install the pneumatic regulator (E) and gauge to control the inlet pressure. See **Models** on page 3 for your model's maximum pneumatic pressure.

NOTE: If less than 100 psi supply pressure is used, the pump's maximum output pressure will be decreased proportionally.

Minimum Pneumatic Pressure can be found by first finding the table that corresponds to the plunger size (see **Minimum Pneumatic Pressures by Fluid Plunger Size and Outlet Pressures** on page 12). Next, using the column that corresponds to the pneumatic motor size, find the row equal to or slightly greater than the outlet pressure of the pump. The value is the Minimum Pneumatic Pressure required to achieve the fluid outlet pressure.

2. Install a pneumatic line filter (C) to keep debris from affecting pump performance and to increase pump life.

NOTE: Keep the needle valve knob (B) closed at this point to keep the pump from operating without fluid, which minimizes seal wear.

3. Attach a pneumatic line to the 1/4 in. female NPT port on the needle valve (B).

NOTE: In some applications the air source may contain solvents that can breakdown the factory grease in the air motor. This may cause the air motor to stall. If the air motor stalls, then install an in-line pneumatic lubricator. See **Additional Kits & Accessories** on page 39 for the recommended pneumatic lubricator

Route Exhaust to Remote Location

Replace the muffler (215) with a pneumatic line to route exhaust to a remote location.





NOTICE

Due to the operational design of the pneumatic valve, 3.5% of the exhaust is not recoverable, and will vent to atmosphere. However, a 100% Exhaust Capture Kit, B32651, is available for the 4.5 in. air motor (PCI-0450-xxx-xxx-xx-x-x) only.

Connect Chemical Outlet

1. Connect a fluid line from the pump outlet (M) to the injection point.
2. Install a fluid pressure relief valve (J) on the outlet side of the pump.

NOTE: A pressure relief valve is available from Graco and can be connected back to the tank or directly to the inlet side of the pump. See **Kits and Accessories** on page 40.

				
In the event of an injection line blockage, to reduce the risk of skin injection and damage to the pump, ensure the pressure relief valve is set at or below the maximum working pressure of the pump.				

3. Set the pressure relief valve at or below the maximum working pressure of the pump.

Minimum Pneumatic Pressures by Fluid Plunger Size and Outlet Pressures

Actual running pressure must be set in field to avoid stalling. See **Performance Charts**, starting on page 43, for maximum flows at any given pressure.

250 Pneumatic Motor Minimum Air Pressure psi (MPa, bar)			
Outlet Pressure psi (MPa, bar)	3/8 Inch Fluid Plunger	1/2 Inch Fluid Plunger	3/4 Inch Fluid Plunger
0 (0, 0)	15.0 (0.1, 1.0)	15.0 (0.1, 1.0)	15.0 (0.1, 1.0)
250 (1.7, 17.2)	15.0 (0.1, 1.0)	15.0 (0.1, 1.0)	29.8 (0.2, 2.1)
500 (3.4, 34.5)	15.0 (0.1, 1.0)	26.3 (0.2, 1.8)	59.6 (0.4, 4.1)
625 (4.3, 43.1)	15 (0.1, 1.2)	32.8 (0.3, 2.7)	74.5 (0.6, 6.2)
750 (5.2, 51.7)	16.9 (0.1, 1.2)	39.4 (0.3, 2.7)	89.4 (0.6, 6.2)
840 (6.9, 68.9)	18.9 (0.2, 1.6)	44.1 (0.4, 3.6)	100.1 (0.8, 8.2)
1000 (6.9, 68.9)	22.5 (0.2, 1.6)	52.5 (0.4, 3.6)	
1111 (7.7, 76.6)	25.0 (0.2, 1.7)	58.4 (0.4, 4.0)	
1500 (10.3, 103.4)	33.8 (0.2, 2.3)	78.8 (0.5, 5.4)	
1600 (11.0, 110.3)	36.0 (0.2, 2.5)	84.1 (0.6, 5.8)	
1905 (13.1, 131.3)	42.9 (0.3, 3.0)	100.1 (0.7, 7.2)	
2000 (13.8, 137.9)	45.0 (0.3, 3.1)		
2250 (15.5, 155.1)	50.6 (0.3, 3.5)		
2500 (17.2, 172.4)	56.3 (0.4, 3.9)		
2750 (19.0, 189.6)	61.9 (0.4, 4.3)		
3000 (20.7, 206.8)	67.5 (0.5, 4.7)		
3250 (22.4, 224.1)	73.1 (0.5, 5.0)		
3500 (24.1, 241.3)	78.8 (0.5, 5.4)		
3750 (25.9, 258.6)	84.4 (0.6, 5.8)		
4000 (27.6, 275.8)	90.0 (0.6, 6.2)		
4250 (29.3, 293.0)	95.6 (0.7, 6.6)		
4440 (30.6, 306.1)	99.9 (0.7, 6.9)		

For applications where the exhaust is ported to a pressurized location, compute the difference between the inlet and outlet pressures to get the pneumatic pressure to be used in the above tables. Minimum pressure differential is 15 psi (0.1 Mpa, 1.0 bar).

350 Pneumatic Motor Minimum Air Pressure psi (MPa, bar)			
Outlet Pressure psi (MPa, bar)	1/2 Inch Fluid Plunger	3/4 Inch Fluid Plunger	1 Inch Fluid Plunger
0 (0, 0)	15.0 (0.1, 1.0)	15.0 (0.1, 1.0)	15.0 (0.1, 1.0)
250 (1.7, 17.2)	15.0 (0.1, 1.0)	15.2 (0.1, 1.0)	20.4 (0.1, 1.4)
500 (3.4, 34.5)	15.0 (0.1, 1.0)	30.4 (0.2, 2.1)	40.8 (0.3, 2.8)
750 (5.2, 51.7)	20.1 (0.1, 1.4)	45.6 (0.3, 3.1)	61.2 (0.4, 4.2)
1000 (6.9, 68.9)	26.8 (0.2, 1.8)	60.8 (0.4, 4.2)	81.6 (0.6, 5.6)
1225 (8.4, 84.5)	32.8 (0.2, 2.3)	74.5 (0.5, 5.2)	100.0 (0.7, 7.0)
1250 (8.6, 86.2)	33.5 (0.2, 2.3)	76.0 (0.5, 5.2)	
1500 (10.3, 103.4)	40.2 (0.3, 2.8)	91.2 (0.6, 6.3)	
1650 (11.4, 113.8)	44.2 (0.3, 3.2)	100.3 (0.7, 7.3)	
1750 (12.1, 120.7)	46.9 (0.3, 3.2)		
2180 (15.0, 150.3)	58.4 (0.4, 4.0)		
2250 (15.5, 155.1)	60.3 (0.4, 4.2)		
2500 (17.2, 172.4)	67.0 (0.5, 4.6)		
2750 (19.0, 189.6)	73.7 (0.5, 5.1)		
3136 (21.6, 216.2)	84.1 (0.6, 5.8)		
3250 (22.4, 224.1)	87.1 (0.6, 6.0)		
3500 (24.1, 241.3)	93.8 (0.6, 6.5)		
3750 (25.9, 258.6)	100.5 (0.7, 6.9)		

For applications where the exhaust is ported to a pressurized location, compute the difference between the inlet and outlet pressures to get the pneumatic pressure to be used in the above tables. Minimum pressure differential is 15 psi (0.1 Mpa, 1.0 bar).

450 Pneumatic Motor Minimum Air Pressure psi (MPa, bar)			
Outlet Pressure psi (MPa, bar)	1/2 Inch Fluid Plunger	3/4 Inch Fluid Plunger	1 Inch Fluid Plunger
0 (0, 0)	15.0 (0.1, 1.0)	15.0 (0.1, 1.0)	15.0 (0.1, 1.0)
250 (1.7, 17.2)	15.0 (0.1, 1.0)	15.0 (0.1, 1.0)	15.0 (0.1, 1.0)
500 (3.4, 34.5)	15.0 (0.1, 1.0)	18.4 (0.1, 1.3)	24.7 (0.2, 1.7)
750 (5.2, 51.7)	15.0 (0.1, 1.0)	27.6 (0.2, 1.9)	37.0 (0.3, 2.6)
1000 (6.9, 68.9)	16.2 (0.1, 1.1)	36.8 (0.3, 2.5)	49.4 (0.3, 3.4)
1250 (8.6, 86.2)	20.3 (0.1, 1.4)	46.0 (0.3, 3.2)	61.7 (0.4, 4.3)
1500 (10.3, 103.4)	24.3 (0.2, 1.7)	55.2 (0.4, 3.8)	74.1 (0.5, 5.1)
1750 (12.1, 120.7)	28.4 (0.2, 2.0)	64.4 (0.4, 4.4)	86.4 (0.6, 6.0)
2000 (13.8, 137.9)	32.4 (0.2, 2.2)	73.6 (0.5, 5.1)	98.8 (0.7, 6.8)
2025 (14.0, 139.6)	32.8 (0.3, 2.5)	74.5 (0.6, 5.7)	100.0 (0.8, 7.7)
2250 (15.5, 155.1)	36.5 (0.3, 2.5)	82.8 (0.6, 5.7)	
2500 (17.2, 172.4)	40.5 (0.3, 2.8)	91.9 (0.6, 6.3)	
2730 (18.8, 188.2)	44.3 (0.3, 3.1)	100.4 (0.7, 7.0)	
2750 (19.0, 189.6)	44.6 (0.3, 3.1)		
3000 (20.7, 206.8)	48.6 (0.3, 3.4)		
3250 (22.4, 224.1)	52.7 (0.4, 3.6)		
3600 (24.8, 248.2)	58.4 (0.4, 4.0)		
3750 (25.9, 258.6)	60.8 (0.4, 4.2)		
4000 (27.6, 275.8)	64.9 (0.4, 4.5)		
4250 (29.3, 293.0)	68.9 (0.5, 4.8)		
4500 (31.0, 310.3)	73.0 (0.5, 5.0)		
4750 (32.8, 327.5)	77.0 (0.5, 5.3)		
5200 (35.9, 358.5)	84.3 (0.6, 5.8)		
5250 (36.2, 362.0)	85.1 (0.6, 5.9)		
5500 (37.9, 379.2)	89.2 (0.6, 6.1)		
5750 (39.6, 396.4)	93.2 (0.6, 6.4)		
6000 (41.4, 413.7)	97.3 (0.7, 6.7)		
6175 (42.6, 425.8)	100.1 (0.7, 7.0)		

For applications where the exhaust is ported to a pressurized location, compute the difference between the inlet and outlet pressures to get the pneumatic pressure to be used in the above tables. Minimum pressure differential is 15 psi (0.1 Mpa, 1.0 bar).

Operation

Pressure Relief Procedure

 Follow the Pressure Relief Procedure whenever you see this symbol.



This equipment stays pressurized until pressure is manually relieved. To help prevent serious injury from pressurized fluid, such as skin injection and splashing fluid, follow the **Pressure Relief Procedure** when you stop dispensing and before cleaning, checking, or servicing the equipment.

NOTE: Always discharge fluid into an approved container or location.

1. Shut off all fluid and pneumatic lines (A, K, & P) using the two fluid shutoff valves (H) and the pneumatic needle valve (B).
2. Slowly loosen the fluid lines to (K & P) at the pump outlets (L & M) to bleed off any residual pressure.
3. Disconnect the fluid lines (K & P) from pump outlets (L & M).

Flush the Equipment

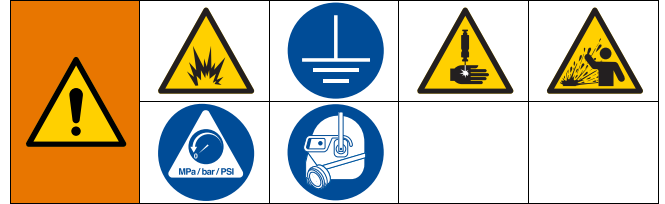

To avoid fire and explosion, always ground equipment and waste container. To avoid static sparking and injury from splashing, always flush at the lowest possible pressure.

- Flush with a fluid that is compatible with the fluid being dispensed and the equipment wetted parts.
1. Follow the **Pressure Relief Procedure**.
 2. Connect inlet to the supply source of the flushing fluid.
 3. Connect outlet to a waste reservoir.
 4. Run the pump until the dispensed fluid is predominately flushing fluid.
 5. Follow the **Pressure Relief Procedure**.

Prime the Pump



1. Verify all connections and fluid lines are tight.

NOTE: The pressure regulator and inlet pneumatic needle valve both effect the pump cycle rate. After inlet pressure is set, the needle valve can serve as a speed control.

2. Adjust pneumatic regulator to desired pressure.
3. Open bleed-type pneumatic valve. Slowly turn pump needle valve counter-clockwise, increasing air flow to the pump.

NOTICE

Pump runaway may occur if the needle valve is opened too far for pressure settings, causing damage to the packing seals (103 and 104).

4. Keep the pump cycle rate less than 1 cycle every 3 seconds only while priming the pump.

Calibrate Chemical Dosage



1. Begin the process by setting the pump to an estimated setting of the flow rate.
2. Follow the instructions provided with your calibration gauge.
3. Adjust the cycle rate with the inlet pneumatic needle valve and/or the pressure regulator.
4. Repeat the test procedure to verify your changes. Repeat as necessary until the desired flow rate is achieved.

Baseline Chemical Dosage Settings

See **Performance Charts**, starting on page 43, for maximum flows at any given pressure.

CPM	3/8 in. Fluid Plunger Pumps		1/2 in. Fluid Plunger Pumps	
	GPD	LPD	GPD	LPD
10	16.4	62.1	36.9	139.5
20	32.8	124.1	73.7	279.0
30	49.2	186.2	110.6	418.6
40	65.6	248.3	147.4	558.1
50	82.0	310.3	184.3	697.6
60	98.4	372.4	221.1	837.1

CPM	3.4 in. Fluid Plunger Pumps		1 in. Fluid Plunger Pumps	
	GPD	LPD	GPD	LPD
10	83.1	314.6	124.0	469.5
20	166.2	629.1	248.1	939.0
30	249.3	943.7	372.1	1408.5
40	332.4	1258.2	496.1	1878.0
50	415.5	1572.8	620.2	2347.5
60	498.6	1887.3	744.2	2817.1

NOTE: Maximum cycle rate is 60 CPM (cycles per minute), and the minimum cycle rate is 10 CPM.

Maintenance

Preventive Maintenance Schedule

The operating conditions of your particular pump determine how often maintenance is required. Establish a preventive maintenance schedule by recording when and what kind of maintenance is needed, and then determine a regular schedule for checking your pump.

Tighten Threaded Connections

Check that all threaded connections are tight at routine intervals.

Tighten Packings

The packings included in your pump have the ability to be adjusted to stop leaks that develop when the seals are worn. If a leak develops in the pump's fluid section, tighten the packing nut clockwise by 1/16 of a turn, or lower, until the leak is eliminated. The life of the packing can be affected by over-tightening the packings. If the packing nut needs to be tightened repeatedly after short intervals, replace the packing.

Storage

If the pump is going to be stored for long periods, it is recommended that the pump be flushed with a light-weight oil or rust prohibiter to protect pump components. Store the pump with protective fluid inside whenever possible.

Troubleshooting

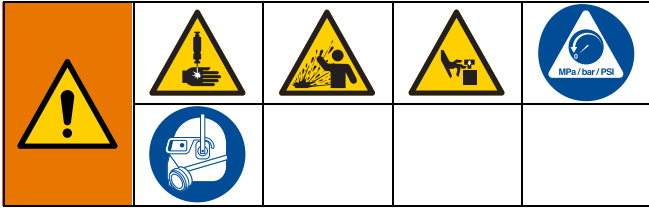

1. Follow **Pressure Relief Procedure**, page 15, before checking or repairing pump.
2. Check all possible problems and causes before dis-assembling pump.

Problem	Cause	Solution
Pump runs, but the chemical does not discharge at the correct rate.	Inlet check is clogged with debris.	Remove debris from check valve.
	Inlet check o-ring is damaged.	Evaluate the o-ring chemical compatibility, and replace as required.
	Air is in the pump head.	Ensure suction lines are tight, and then prime the pump. When injecting into a gas line, inspect the outlet check valve to ensure gas is not back feeding into the pump head.
	Packing leak.	Tighten packing nut. If leak persists then evaluate packing chemical compatibility, and replace.
	Inadequate chemical supply.	Ensure the chemical tank is filled. Inspect and replace chemical supply filter.
	Incorrect calibration.	Ensure the calibration gauge is functioning properly with adequate venting.
Problem	Cause	Solution
Pump does not stroke.	Inadequate pneumatic supply.	If the pressure is too low then increase the pneumatic supply pressure. If the volume is too low, then ensure the pneumatic supply volume is adequate to operate the pump.
	Dirty supply gas.	Install a filter
		Replace the filter element
	Inadequate internal lubrication.	Ensure pneumatic supply gas is clean and dry with a working filter. Then lubricate the air motor internals. Add an oiler if pneumatic supply gas contains solvents that are washing out the factory grease. Graco oiler 237212.
	Inconsistent pump changeover.	Replace the pilot valves.
	Stalling on one end of the stroke.	Rebuild or replace the pneumatic valve.
		Replace pilot valves.
	Air is continuously exhausting from muffler.	Rebuild or replace pneumatic valve.
Air is continuously exhausting from motor piston rod.	Replace the piston rod u-cup.	

Problem	Cause	Solution
Chemical is leaking from packing.	Worn packing	Tighten the packing nut. If leaking persists then replace packing. NOTE: the packing nut is set from the factory, and does not require tightening upon initial installation.
		Consult the Chemical Compatibility Guide to ensure the seal in use is compatible with the chemicals being pumped. NOTE: The Chemical Compatibility Guide can be found at www.graco.com .
Problem	Cause	Solution
Icing inside motor.	Pneumatic motor is operating at a high pressure or high cycle rate.	Reduce pressure, cycle rate, or duty cycle of motor.
		Reduce the dew-point of compressed air in the moisture coalescing filter.
Erratic or accelerated pump speed.	Exhausted fluid supply.	Replace and reprime.
	Worn or clogged check valves or packing.	Remove debris from check valve.
		Replace check valve.



Repair



Before servicing or repairing your pump, verify that pressure is relieved according to the **Pressure Relief Procedure**, page 15, and that all fluid and pneumatic lines are properly shut off, or sealed with compatible valves and disconnected.

Pump

Disconnect Pump

1. Follow the **Pressure Relief Procedure**, page 15.
2. Remove the dust cover (10) by loosening the two screws (11). See FIG. 2.

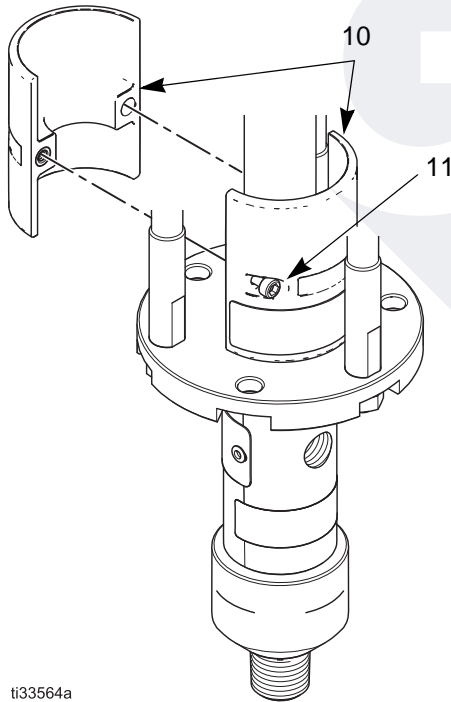

ti33564a

FIG. 2 Remove dust cover

3. Push the retaining spring (9) up and push out the connector pin (8) using a screwdriver or punch. See FIG. 3.

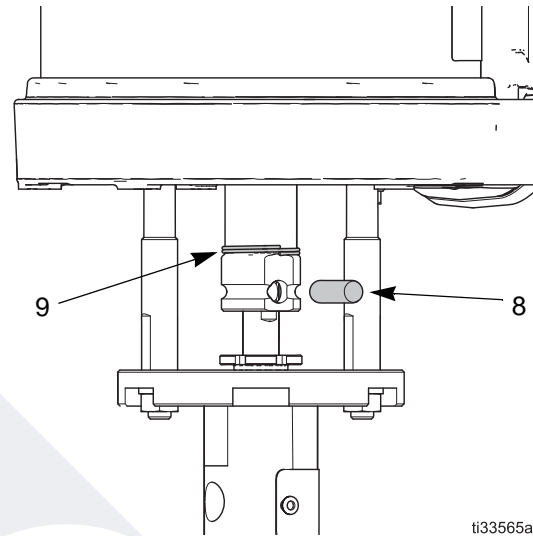

ti33565a

FIG. 3 Retaining spring and connector pin

4. Loosen the fluid cylinder (105) and carefully slide away from the lower pump adapter (5).

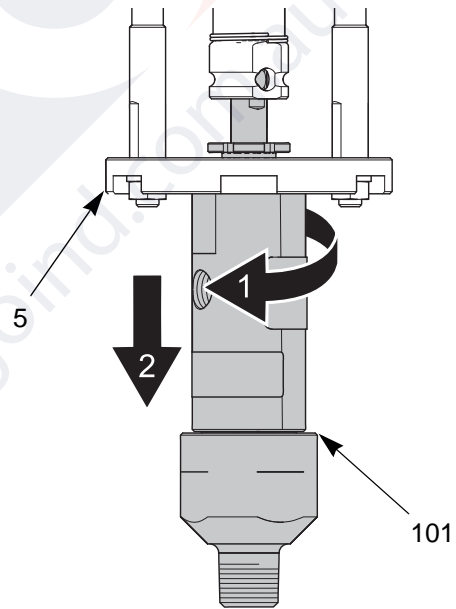

ti33566a

FIG. 4 Remove fluid cylinder

Pump Repair

1. Remove the cylinder cap (102) from the fluid cylinder (105).

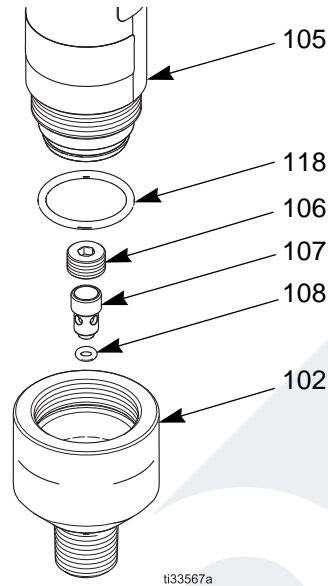

FIG. 5 Fluid cylinder cap assembly

2. Remove the check retainer (106) and lower check poppet (107) from the fluid cylinder cap (102).
3. Inspect the fluid cylinder cap O-ring (118) and lower poppet o-ring (108) for wear or damage, and replace if necessary.
4. Install the lower check poppet (107) into the fluid cylinder cap (102), and then install the check retainer (106).

5. Push the narrow end of the plunger (109) into the top of the fluid cylinder (105), and remove the entire fluid plunger assembly from the bottom of the fluid cylinder (105).

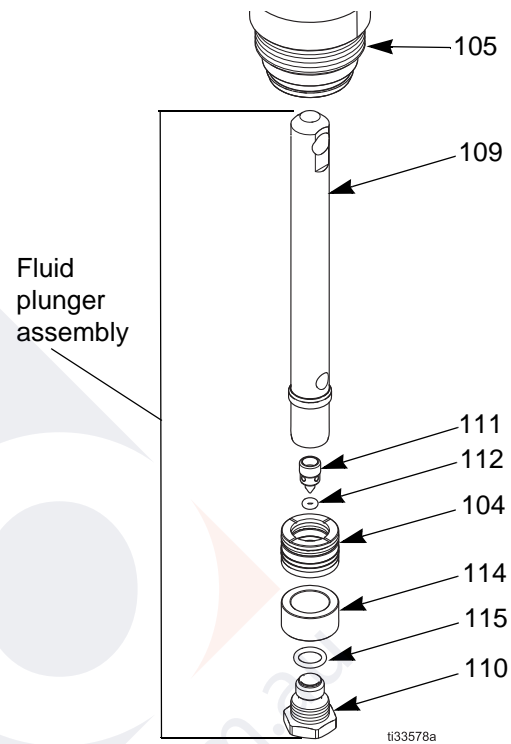

FIG. 6 Fluid plunger assembly

6. Remove the plunger check valve seat (110) and upper check poppet (111) from the fluid plunger (109).
7. Inspect the check seat o-ring (115) and upper poppet o-ring (112) for wear or damage, and replace if necessary.
8. Reinsert the fluid plunger (109), and then the upper check poppet (111).

9. Inspect the bottom packing seal set (104) and bottom bearing (114) for wear or damage, and replace if necessary. Lubricate prior to reassembly.

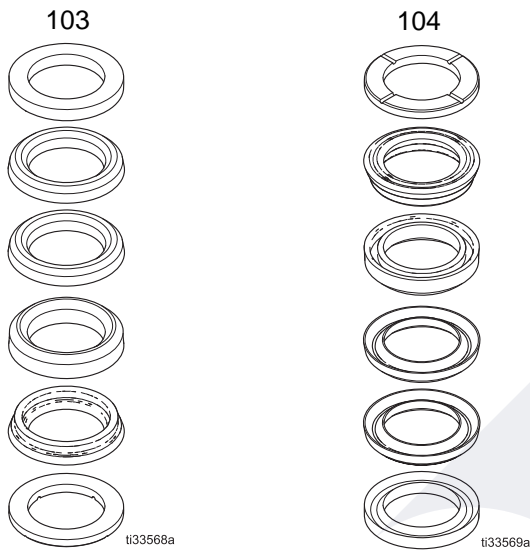

FIG. 7 Packing seal sets

10. Install the check valve seat (110) into the fluid plunger (109) with blue medium thread locker, and torque to 20 in-lb.

11. Remove the packing nut (119) from the top of the fluid cylinder (105).

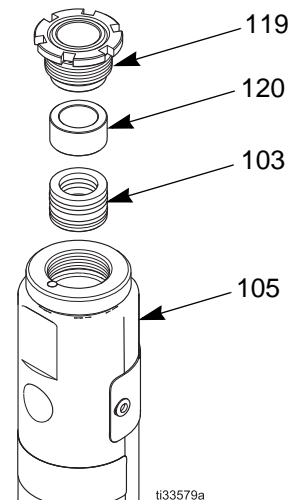

FIG. 8 Top packing seal assembly

12. Push the top packing seal set (103) and top bearing (120) out of the fluid cylinder (105).
13. Inspect the top packing seal set (103) and top bearing (120) for wearing or damage, and replace if necessary. Lubricate prior to reassembly.

14. Install the packing nut (119) into the top of the fluid cylinder (105) with pipe sealant, and set the distance to 5/32 or 0.156 inches. A 5/32 in. hex wrench may be used to set the gap.

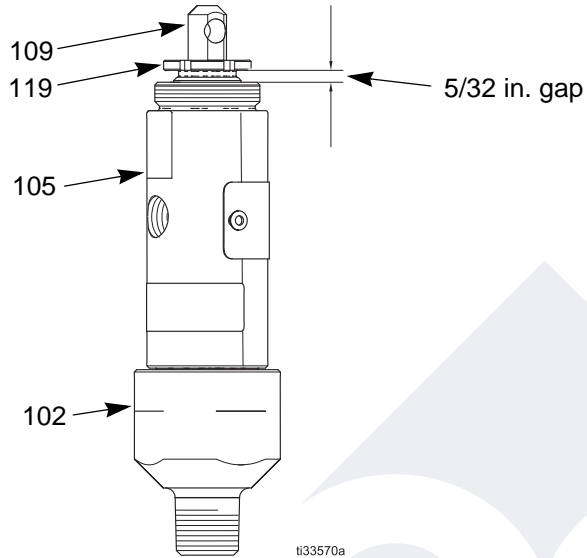

FIG. 9: Tightening the packing nut

15. Install the fluid plunger assembly in the bottom of the fluid cylinder (105) until flush with the end of the fluid cylinder (105). Lubricate the fluid plunger packing and shaft prior to assembly.

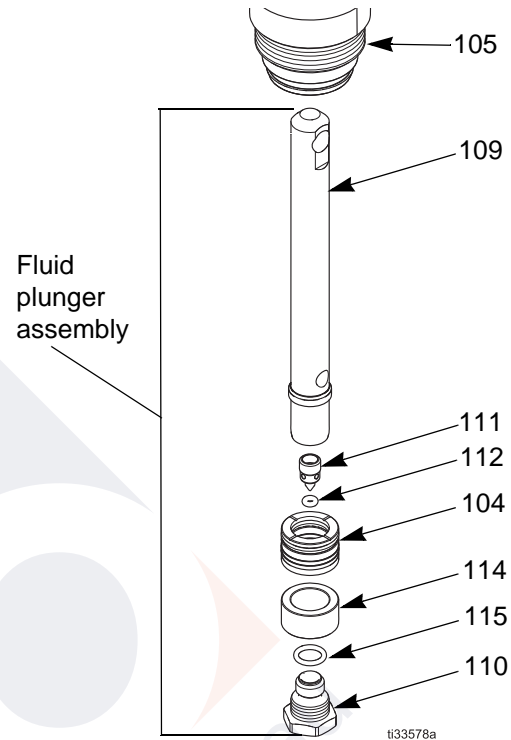

FIG. 10 Fluid plunger assembly

16. Install the fluid cylinder cap (102) and torque to 180 ft-lb. Lubricate the cylinder threads prior to assembly.

NOTE: If the packing nut (104) is over-tightened, the pump may wear the packing prematurely.

Reconnect Pump

NOTICE

The pump can be damaged if the fluid cylinder is not screwed all the way into the adapter plate. Be sure to fully screw the fluid cylinder (105) into the adapter plate (5).

1. Align the hole in the displacement rod with the hole in the pneumatic motor rod. Use a screwdriver to push in the pin (8).

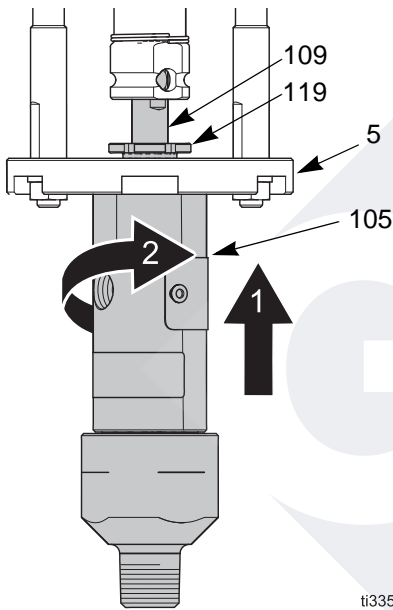

ti33571a

FIG. 11 Reconnect fluid cylinder

2. Screw the fluid cylinder into the adapter plate (5) until it stops. Tighten fluid cylinder (105) to 30 ft-lbs (40 N•m).

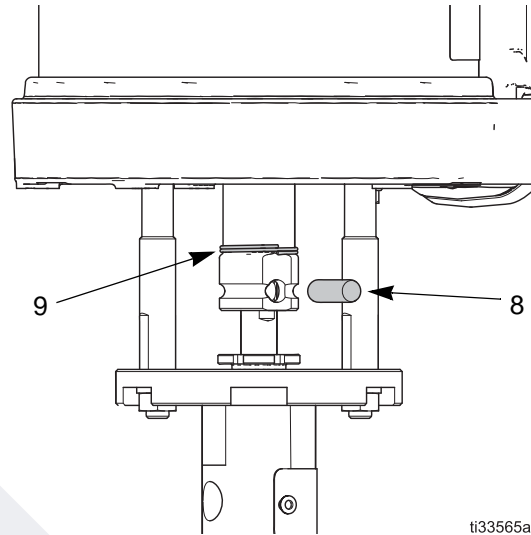

ti33565a

FIG. 12 Retaining spring and connector pin

3. Align the hole in the displacement rod with the hole in the pneumatic motor rod. Use a screwdriver to push in the pin (8).
4. Push the retaining spring (9) into place to cover the pin.
5. Replace the dust cover (10) and secure by tightening the two screws (11).

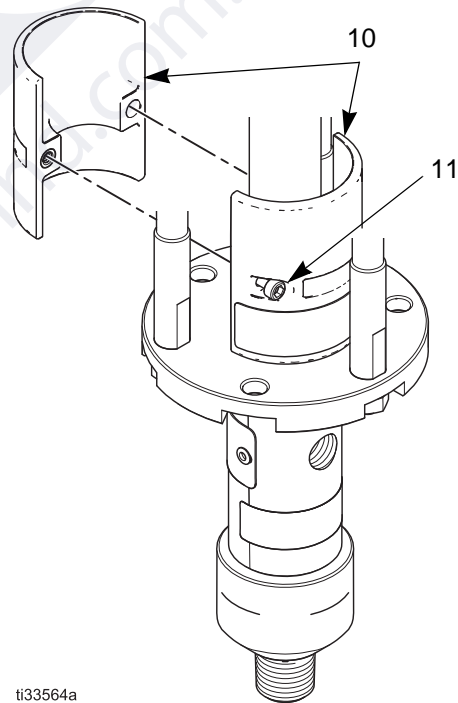

ti33564a

FIG. 13 Replace dust cover

Pneumatic Valve



Replace Complete Pneumatic Valve

1. Stop the pump. Follow **Pressure Relief Procedure**, page 15.
2. Disconnect the pneumatic line to the motor.
3. See FIG. 20 on page 30. Remove four screws (211). Remove the pneumatic valve (214) and gasket (209*♦).
4. To repair the pneumatic valve, go to **Disassemble the Pneumatic Valve**, page 25. To install a replacement pneumatic valve, continue with step 5.
5. Align the new pneumatic valve gasket (209*♦) on the manifold, then attach the pneumatic valve (214). Torque screws (211) to 95-105 in-lb (11-12 N•m).
6. Reconnect the pneumatic line to the motor.

Replace Seals or Rebuild Pneumatic Valve

NOTE: Pneumatic Valve Seal Kits are available. See page 39. Parts are marked with an †.

Pneumatic Valve Repair Kits are available. See page 39. Parts are marked with an ♦.

Pneumatic Valve End Cap Kits are available. See page 39. Parts are marked with an ⌘.

Disassemble the Pneumatic Valve

1. Perform steps 1-3 under **Replace Complete Pneumatic Valve**, page 25.
2. See FIG. 14. Use a 2 mm or 5/64 in. hex key to remove two screws (309†♦). Remove the valve plate (305♦), cup (312♦), and spring (311♦).

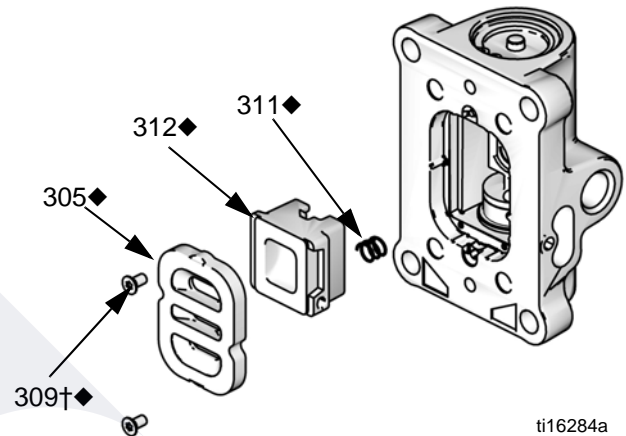
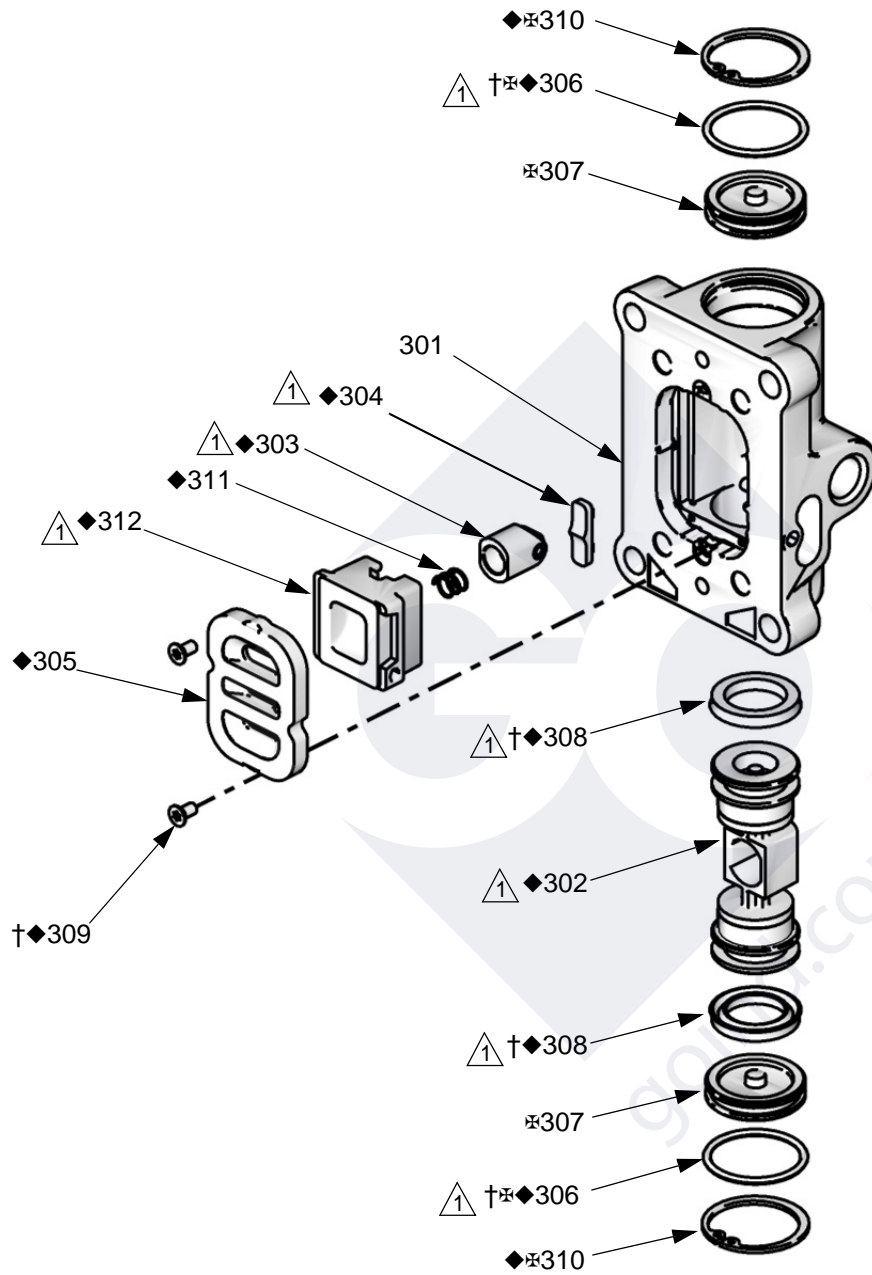

FIG. 14. Pneumatic Plate Removal

3. See FIG. 15. Remove the snap ring (310♦⌘) from each end. Use the piston to push the end caps (307⌘) out of the ends. Remove end cap o-rings (306†⌘♦).
4. Remove the piston (302♦). Remove the u-cup seals (308†♦) from each end, and the detent assembly (303♦) and detent cam (304♦) from the center.



ti16213a

† Apply lubricant.

FIG. 15. Pneumatic Valve Assembly

Reassemble the Pneumatic Valve

1. See FIG. 15. Lubricate detent cam (304♦) and install into housing.
2. See FIG. 16. Lubricate the u-cups (308†♦) and install on the piston (302♦) with lips facing toward the center of the piston.

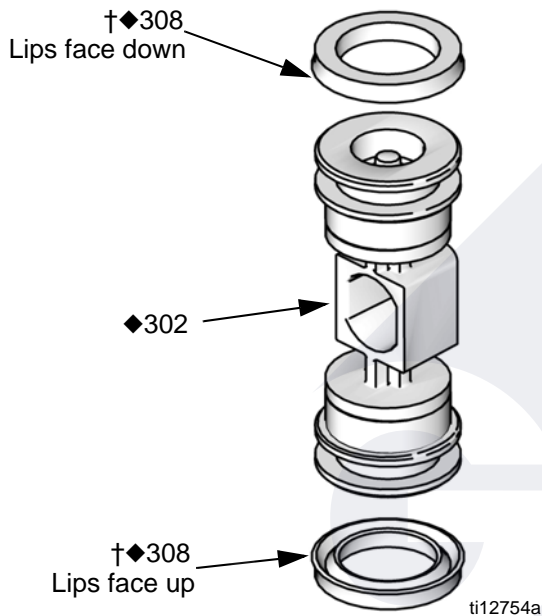

FIG. 16. Pneumatic Valve U-cup Installation

3. See FIG. 15. Lubricate both ends of the piston (302♦) and install it in the housing.
4. Lubricate and install the detent assembly (303♦) into the piston.
5. Lubricate new o-rings (306†*♦) and install on the end caps (307*). Install the end caps into the housing.
6. Install a snap ring (310♦*) on each end to hold end caps in place.

7. Install the spring (311♦). Lubricate and install the pneumatic valve cup (312♦), see FIG. 17. Align the small round magnet with the pneumatic inlet.
8. Install the valve plate (305♦). Tighten the screws (309†♦) to hold it in place.

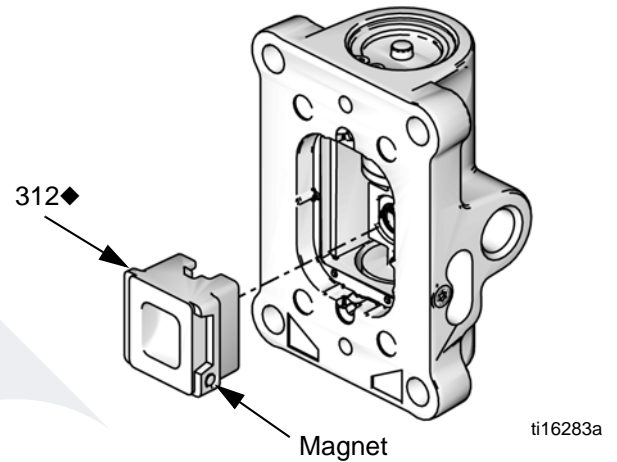

FIG. 17. Pneumatic Valve Cup Installation

Replace Pilot Valves



1. Stop the pump. Follow **Pressure Relief Procedure**, page 15.
2. Disconnect the pneumatic line to the motor.
3. See FIG. 18. Push the safety spring (9) down and hold to access the pilot valve (213) on the bottom cover (201).
4. See FIG. 20 on page 30. Use a 10 mm wrench to remove the old pilot valves (213) from the top and bottom covers.
5. Lubricate and install the new pilot valves (213). Torque to 95-105 in-lb (11-12 N•m).

Disconnect the Pneumatic Motor



1. Stop the pump.
2. Flush the pump, if possible (see page 15). Follow **Pressure Relief Procedure**, page 15.
3. Disconnect the pneumatic line and fluid line and remove the dust guard (10). (See FIG. 2)
4. See FIG. 18. Push the split spring (9) up or down to access the dowel pin (8). Push out the pin, using a screwdriver or punch.
5. Remove the nuts (6) from the bottom of the tie rods (3).
6. Remove the pump lower (7). The adapter plate (5) will remain attached to the pump lower.
7. Remove the split spring (9).
8. Loosen the nuts (4) at the top of the tie rods, then remove the tie rods (3). The mounting bracket (2) is loosened from the motor as the tie rods are removed.
9. Take the motor to a work bench. See **Repair Pneumatic Motor** on page 29.

Reconnect the Pneumatic Motor

1. Replace the motor on the mounting bracket (2).
2. Screw the tie rods (3) into the motor, with the top hex nuts (4) attached. Torque the tie rods to 5-10 ft-lb (7-13 N•m).

NOTE: Always tighten the tie rods (3) before tightening the top hex nuts (4).

3. Tighten the top hex nuts (4) to secure the mounting bracket (2).
4. Slide the pump with the adapter plate (5) attached onto the tie rods (3). Ensure that the split spring (9) is in place and the pump outlet is oriented as desired.
5. Install the tie rod nuts (6). Torque to 100 in-lb (11 N•m).
6. Align the hole in the fluid plunger (109) with the hole in the pneumatic motor piston rod (218). Use a screwdriver to push in the dowel pin (8).
7. Push the split spring (9) into place to cover the dowel pin (8).
8. Replace the dust guard (10).

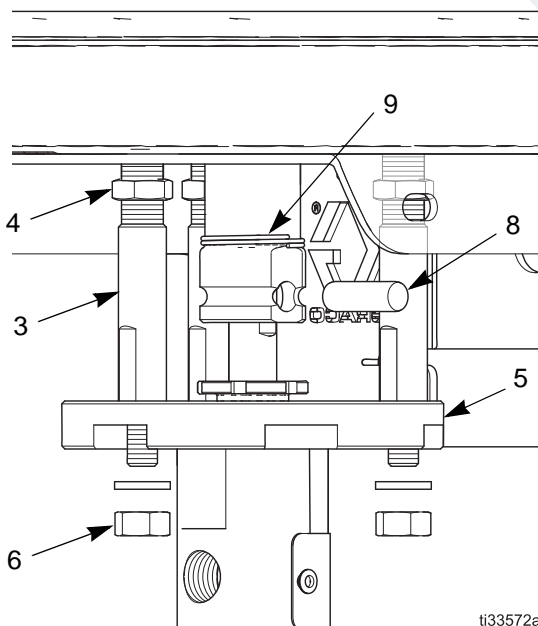

ti33572a

FIG. 18 Retaining spring and connector pin

Repair Pneumatic Motor



NOTE: Complete Pneumatic Motor Replacement Kits are available. Order 24G694 (3.5 in. motor).

NOTE: Pneumatic Motor Seal Kits are available. See page 37 for the correct kit for your motor. Parts included in the kit are marked with an asterisk (*). For best results, use all the parts in the kit.

Disassemble the Pneumatic Motor

1. See FIG. 20. Use a 10 mm socket wrench to remove four screws (211). Remove the pneumatic valve (214) and gasket (209*♦†).
2. Remove four screws (211) and remove the manifold (220) and two gaskets (208*).
3. Use a 10 mm socket wrench to remove the pilot valves (213) from the top and bottom cover.
4. Use a 13 mm socket wrench to remove the tie bolts (212).
5. Remove the top cover (210). Remove the o-ring (202*). *On 3.5 in. motors only*, remove the plug (231) and o-ring (230*).
6. Remove the shield (206) and cylinder (205).
7. Remove the o-ring (204*) from the piston.
8. Secure the piston (219) in a vise with soft jaws. Use a wrench on the flats of the rod (218) to remove the rod and bottom cover assembly (201) from the piston.
9. Remove the rod from the bottom cover assembly.
10. Remove retaining ring (217), u-cup seals (207*), and o-ring (202*) from the bottom cover.

Reassemble the Pneumatic Motor

NOTE: For easier reassembly, start with the top cover (210) turned over on the workbench and assemble the pneumatic motor upside-down.

1. Lubricate and install the o-ring (202*) on the top cover (210).
2. Lubricate the inside of the cylinder (205). Lower the cylinder onto the top cover (210).
3. Install the shield (206) around the cylinder (205) and in the groove on the top cover (210).
4. See FIG. 19. Lubricate and install new u-cup seal (207*) in the bottom of the bearing in the bottom cover (201). The lips must face down. Lubricate and install new u-cup seal (207*) in the top of the bearing. Lips must face up. Install retaining ring (217).

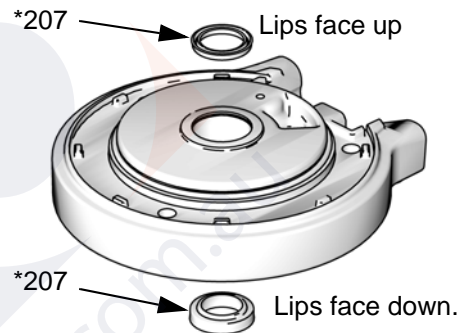

ti16285a

FIG. 19. Pneumatic Motor U-cup Installation

⚠ Apply lubricant.

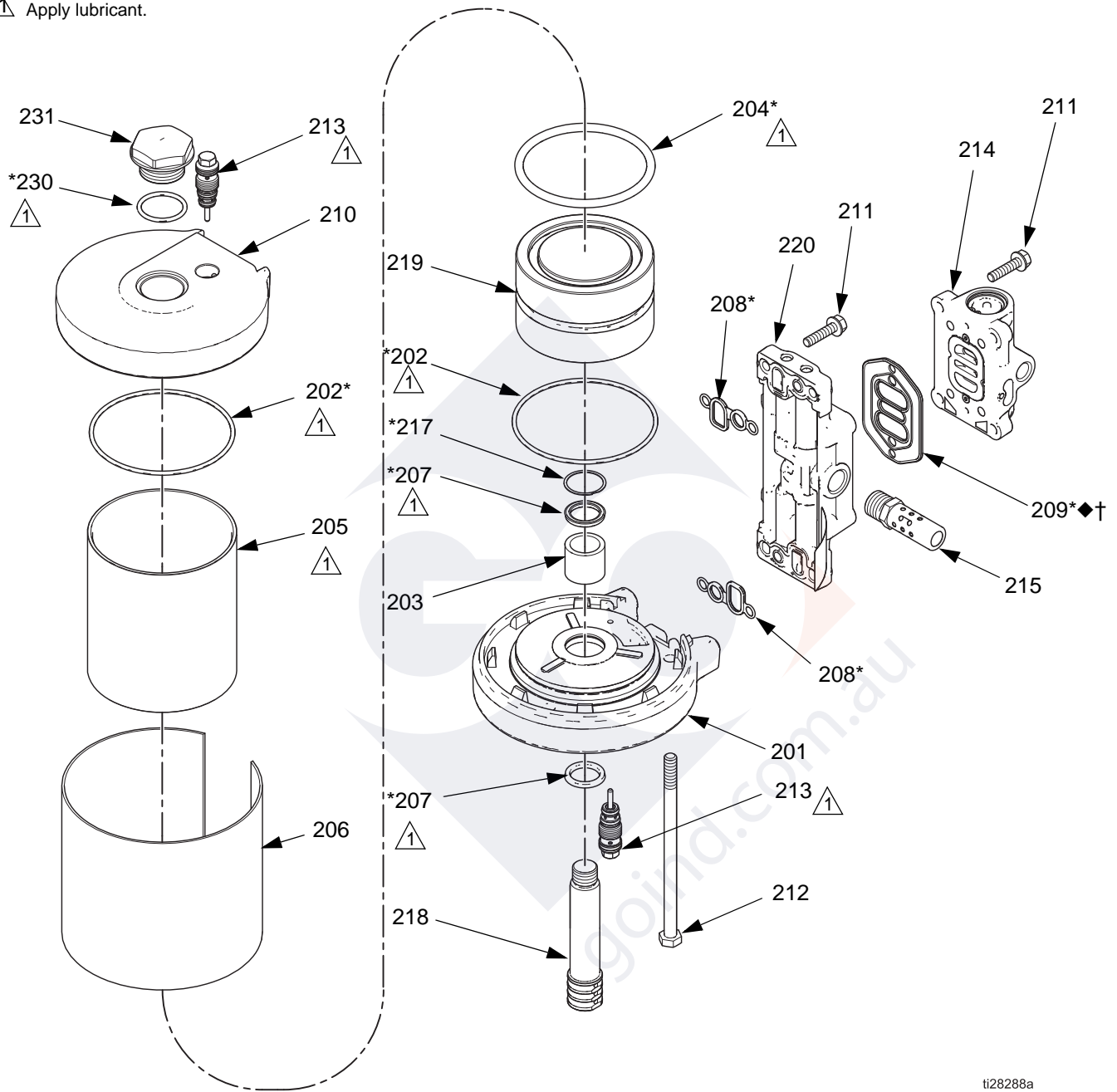

ti28288a

FIG. 20. Pneumatic Motor Assembly

5. Lubricate and install the o-ring (202*) on the bottom cover (201).
 6. Carefully push the threaded end of the rod (218) up through the bottom cover (201).
 7. Apply 16G561 adhesive to the threads of the rod (218). Screw the piston (219) onto the rod. Place the piston in a vise with soft jaws and torque to 35-40 ft-lb (47-54 N•m).
 8. Lubricate and install the o-ring (204*) on the piston (219).
 9. See FIG. 21. Carefully place the bottom cover/piston assembly on the cylinder (205), sliding the piston (219) into the cylinder. The manifold surfaces of the top and bottom covers must align. Be sure the shield (206) is in the groove on both the top and bottom covers.
 10. Install the tie bolts (212) hand tight.
 11. Install two gaskets (208*) on the manifold (220). Install the manifold (220). Torque screws (211) to 95-105 in-lb (10.7-11.9 N•m).
- NOTE:** The manifold is reversible for ease of placement of muffler or remote exhaust.
12. Align the pneumatic valve gasket (209*♦†) on the manifold, then attach the pneumatic valve (214). Torque screws (211) to 95-105 in-lb (11-12 N•m).
 13. Tighten the tie bolts (212) halfway. Work in a criss-cross pattern. Check that the shield (206) remains in the grooves on both covers. Continue tightening the bolts in pattern to 11-13 ft-lb (15-18 N•m).
 14. Lubricate the o-ring (230*). Install it and the plug (231) in the top cover (210).
 15. Lubricate and install pilot valves (213) in top and bottom cover. Torque to 95-105 in-lb (11-12 N•m).
 16. See **Reconnect the Pneumatic Motor** on page 28.

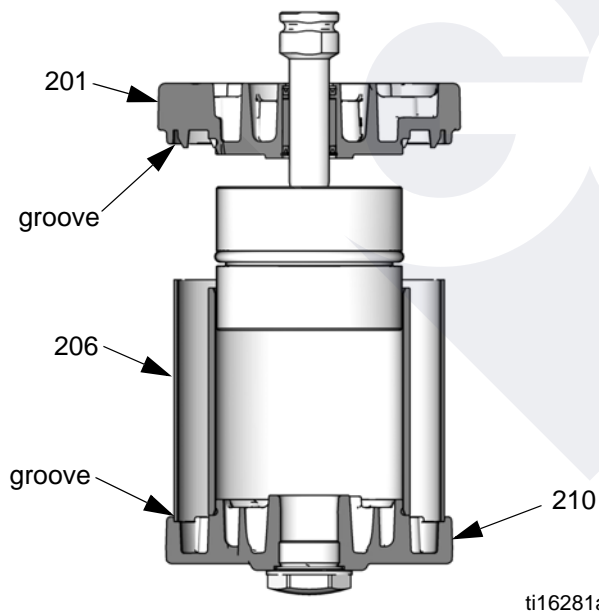
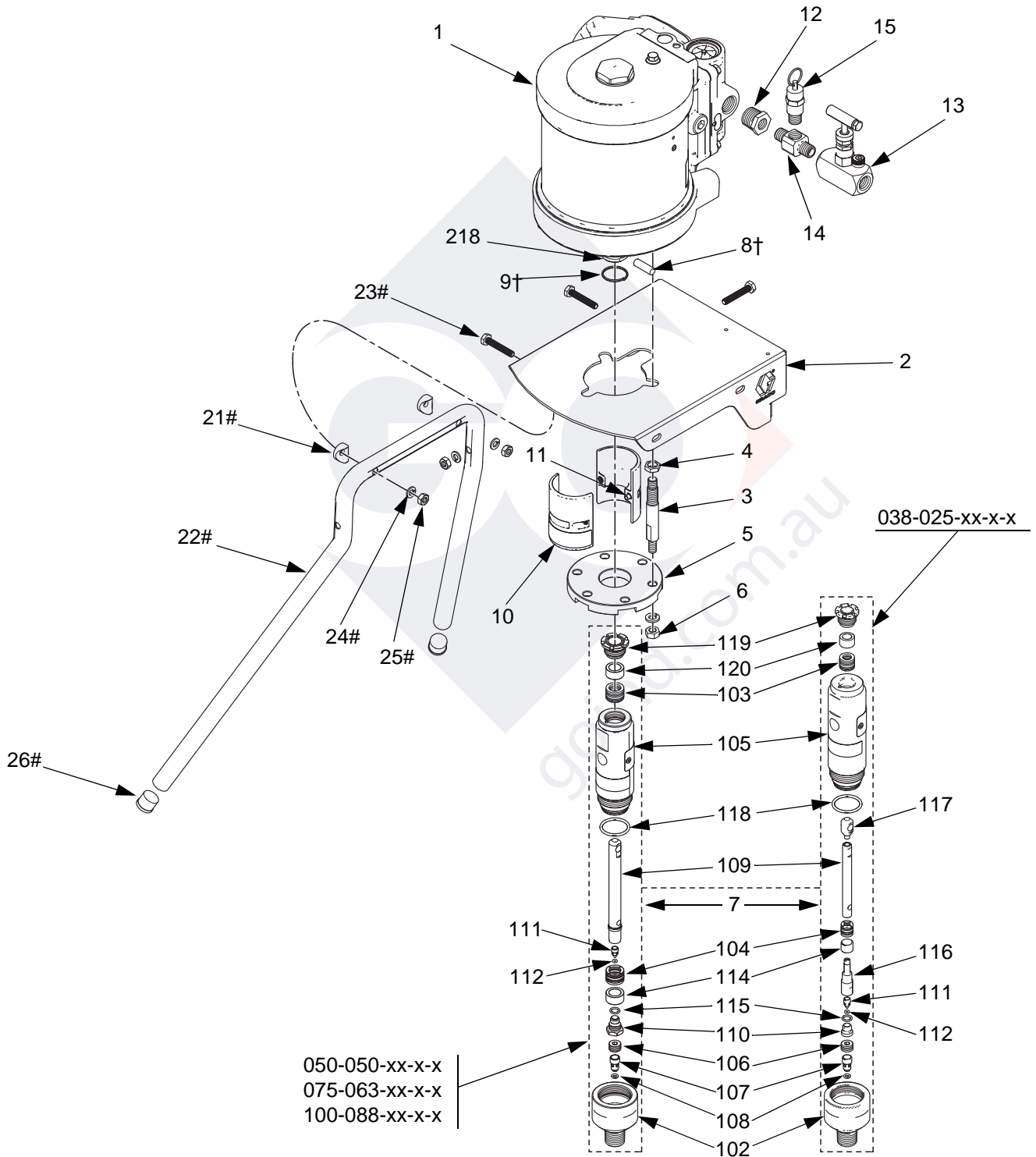

FIG. 21. Align Shield in Grooves on Covers

Parts

Python XL-DA Pneumatic Pump

PCI-0450-038-025-XC-1-A shown



ti33573a

Python XL Pump Lower Parts List

Ref.	Part	Description	Qty
1	B32865	Pneumatic motor, 2.5 in.	1
	B32866	Pneumatic motor, 3.5 in.	1
	B32867	Pneumatic motor, 4.5 in.	1
2	B32652	Wall bracket	1
3	B32273	Motor tie rod	3
4	--	Jam hex nut	3
5	B32269	Lower adapter (3/8 in. and 1/2 in. plungers)	1
	B32270	Lower adapter (3/4 in. plungers)	1
	B32653	Lower adapter (1 in. plungers)	1
6	--	Nyloc nut, stainless steel	3
7	See Table 4, pg 34	Pump lower	1
8†	B32654	Dowel pin, stainless steel	1
9†	B32655	Split ring, stainless steel	1
10	B32767	Dust/hand guard, 2.5 in.	1
	B32271	Dust/hand guard, 3.5 in.	1
	B32277	Dust/hand guard, 4.5 in.	1
11	--	ES screw	2
12	--	Nipple fitting, hex	1
13	131250	Needle valve	1
14	--	Tee, 1/4m x 1/4m x 1/4f	1
15	131515	Safety valve, 100 PSI	1
21#	B32274	Coved spacer	4
22#	B32274	Stand leg	2
23#	B32274	Hex head bolt, stainless steel	4
24#	B32274	Spring lock washer	4
25#	B32274	Hex nut	4
26#	B32274	Stand leg plug	4
102	B32935	Cylinder cap, 3/8 in. and 1/2 in.	1
	B32936	Cylinder cap, 3/4 in.	1
	B32937	Cylinder cap, 1 in.	1
103†	See Table 5, pg 35	Primary top packing seal	1
104	See Table 6, pg 35	Secondary bottom packing seal	1
105	See Table 1, pg 34	Fluid cylinder	1
106	B32942	Check retainer, 3/8 in. and 1/2 in.	1
	B32943	Check retainer, 3/4 in.	1
	B32944	Check retainer, 1 in.	1

Ref.	Part	Description	Qty
107	See Table 8, pg 35	Lower check poppet, included with upper check poppet (ref. 111)	1
108	See Table 8, pg 35	O-ring, lower poppet, included with upper check poppet (ref. 111)	1
109†	See Table 3, pg 34	Fluid plunger	1
110	B32938	Check seat, 3/8 in.	1
	B32939	Check seat, 1/2 in.	1
	B32940	Check seat, 3/4 in.	1
	B32941	Check seat, 1 in.	1
111	See Table 8, pg 34	Upper check poppet	1
112	See Table 8, pg 34	O-ring, upper poppet, included with upper check poppet (ref. 111)	1
114	See Table 6, pg 34	Bottom bearing, included with packing seal (ref. 104)	1
115	See Table 7, pg 35	O-ring, check seat	1
116	See Table 3, pg 34	Check housing, included with fluid plunger (ref. 109)	1
117†	See Table 3, pg 34	Connector, included with fluid plunger (ref. 109)	2
118	B32932	O-ring, 3/8 in. and 1/2 in.	1
	B32933	O-ring, 3/4 in.	1
	B32934	O-ring, 1 in.	1
119†	See Table 2, pg 34	Packing nut	1
120†	See Table 5, pg 35	Top bearing, included with packing seal (ref. 103)	2
121 ▲	17G320	Warning label, adhesive	1

▲ Replacement Danger and Warning labels, tags, and cards are available at no cost.

† Included with Lower Kit. See **Lower Configuration** on page 5.

Not included.

Table 1: Fluid Cylinder (ref. 105)

Ref	Part Numbers by Fluid Plunger Size			
	3/8 in.	1/2 in.	3/4 in.	1 in.
Chromex-Coated Fluid Cylinders				
105	B32656	B32657	B32658	B32659
Ceramic-Coated Fluid Cylinders				
105	B32660	B32661	B32662	B32663

Table 2: Packing Nut (ref. 119)

Ref	Part Numbers by Fluid Plunger Size			
	3/8 in.	1/2 in.	3/4 in.	1 in.
119	B32265	B32266	B32267	B32264

Table 3: Fluid Plunger (ref. 109)

Ref	Part Numbers by Fluid Plunger Size			
	3/8 in.	1/2 in.	3/4 in.	1 in.
Chromex-Coated Fluid Plungers				
109	B32918	B32919	B32920	B32921
Ceramic-Coated Fluid Plungers				
109	B32922	B32923	B32924	B32925

Table 4: Pump Lower (ref. 7)

Seal Type	Part Numbers by Fluid Plunger Size			
	3/8 in.	1/2 in.	3/4 in.	1 in.
Chomex-Coated Fluid Plungers				
HNBR	B32953	B32959	B32965	B32971
FFKM	B32954	B32960	B32966	B32972
TFE/P	B32955	B32961	B32967	B32973
Ceramic-Coated Fluid Plungers				
HNBR	B32956	B32962	B32968	B32974
FFKM	B32957	B32963	B32969	B32975
TFE/P	B32958	B32964	B32970	B32976

Table 5: Primary Top Packing Seal (ref. 103)

Seal Type	Part Numbers by Fluid Plunger Size			
	3/8 in.	1/2 in.	3/4 in.	1 in.
HNBR	B32100	B32104	B32129	B32926
FFKM	B32101	B32105	B32130	B32927
TFE/P	B32043	B32044	B32086	B32928

Table 6: Secondary Bottom Packing Seal (ref. 104)

Seal Type	Part Numbers by Fluid Plunger Size			
	3/8 in.	1/2 in.	3/4 in.	1 in.
HNBR	B32096	B32104	B32125	B32929
FFKM	B32097	B32105	B32126	B32930
TFE/P	B32042	B32044	B32085	B32931

Table 7: Check Seat O-Ring (ref. 115)

Seal Type	Part Numbers by Fluid Plunger Size		
	3/8 in. and 1/2 in.	3/4 in.	1 in.
HNBR	B32896	B32899	B32906
FFKM	B32897	B32904	B32907
TFE/P	B32898	B32905	B32908

Table 8: Check Valve Replacement (ref. 111)

Seal Type	Part Numbers by Fluid Plunger Size		
	3/8 in. and 1/2 in.	3/4 in.	1 in.
HNBR	B32991	B32994	B32997
FFKM	B32992	B32995	B32998
TFE/P	B32993	B32996	B32999

Pneumatic Motor Parts

Part No. B32865, 2.5 in. (63.5 mm); B32866, 3.5 in. (88.9 mm), shown

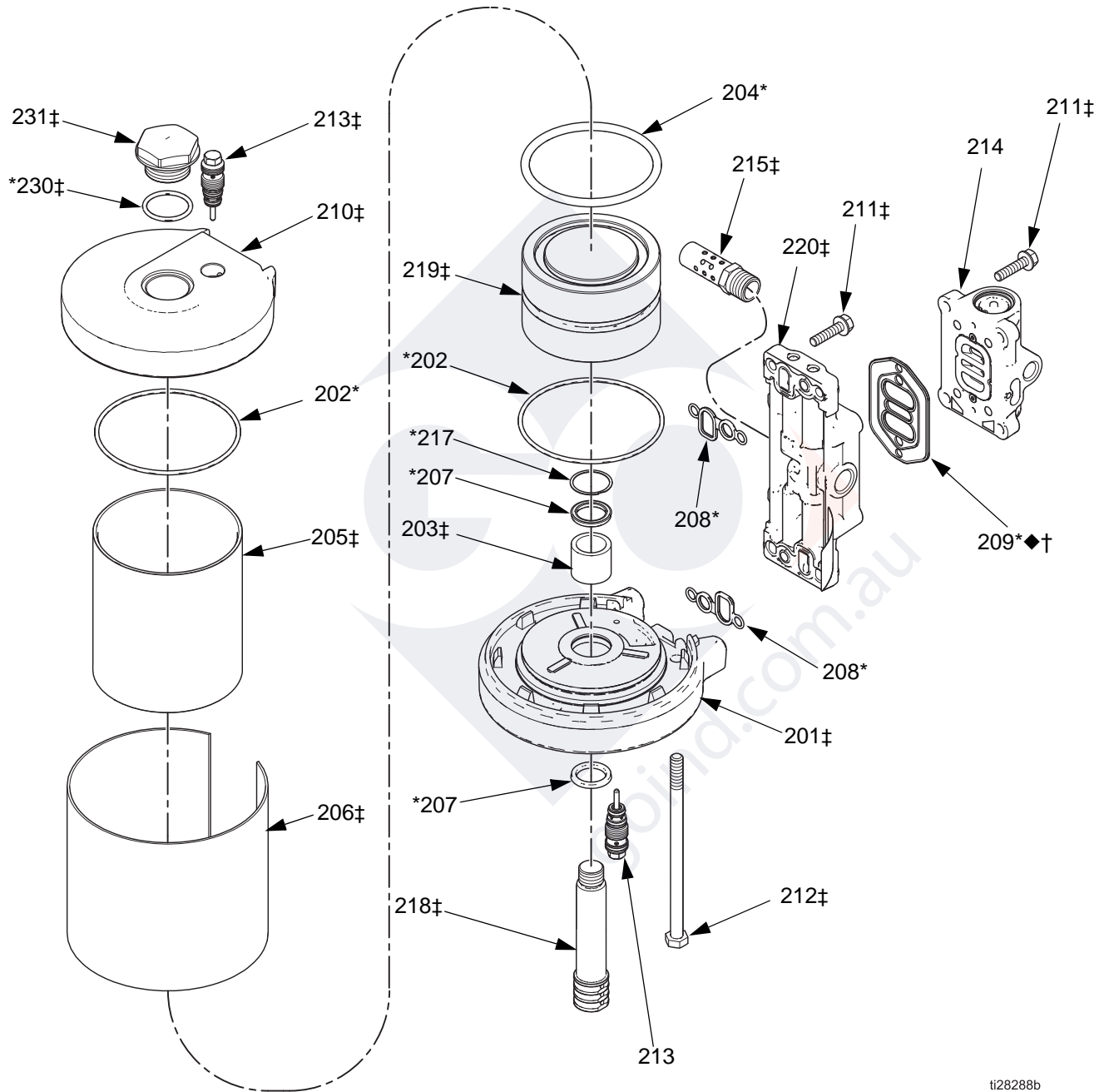

ti28288b

‡ These items are only available in Air Motor Kits B32251 and B32770

Pneumatic Motor Parts

Part number shown:

B32865: 2.5 in. (63.5 mm)

B32866: 3.5 in. (88.9 mm)

B32867: 4.5 in. (114.3 mm)

Ref.	Part	Description	Qty
201	--	Cover, bottom	1
202*	--	O-Ring, cover	2
203	--	Bearing	1
204*	--	O-Ring, piston	1
205	--	Cylinder, motor	1
206▲	B32830	2.5 in. cover, cylinder (includes English warning label)	1
	B32831	3.5 in. cover, cylinder (includes English warning label)	1
	B32832	4.5 in. cover, cylinder (includes English warning label)	1
229▲	15W719	Label, warning (French and Spanish) (not shown)	1
207*	--	Seal, u-cup	2
208*	--	Gasket, manifold	2
209*♦†	--	Gasket, pneumatic valve	1
210	--	Cover, top	1
211	--	Screw, M6 x 25	8
212	--	Bolt, tie, hex head	2, 3
213	24A366	Valve, pilot (pack of 2)	1
214	24A351	Valve, pneumatic; includes items 209 and 211 (qty 4)	1
215	--	Muffler	1
217*	--	Ring, retaining	1
218	--	Rod, pneumatic motor	1
219	--	Kit, piston, motor; includes 204 and 218, and 16G561 adhesive.	1
220	--	Manifold, assembly, includes 208, 209, and 211 (qty. 4)	1
230*	--	O-Ring, top plug	1
231	--	Plug, top cover (ref. 210)	1
	24A539*	2.5 in. Motor Seal Kit	1
	24G700*	3.5 in. Motor Seal Kit	1
	24E986	4.5 in. Motor Seal Kit	1

▲ Replacement Danger and Warning labels, tags, and cards are available at no cost.

† Included in Pneumatic Valve Seal Kit 24A535. See page 39.

♦ Included in Pneumatic Valve Repair Kit 24A537. See page 39.

* Included in Pneumatic Motor Seal Kit 24A539 (2.5 in.), 24G700 (3.5 in.).

Pneumatic Valve Parts

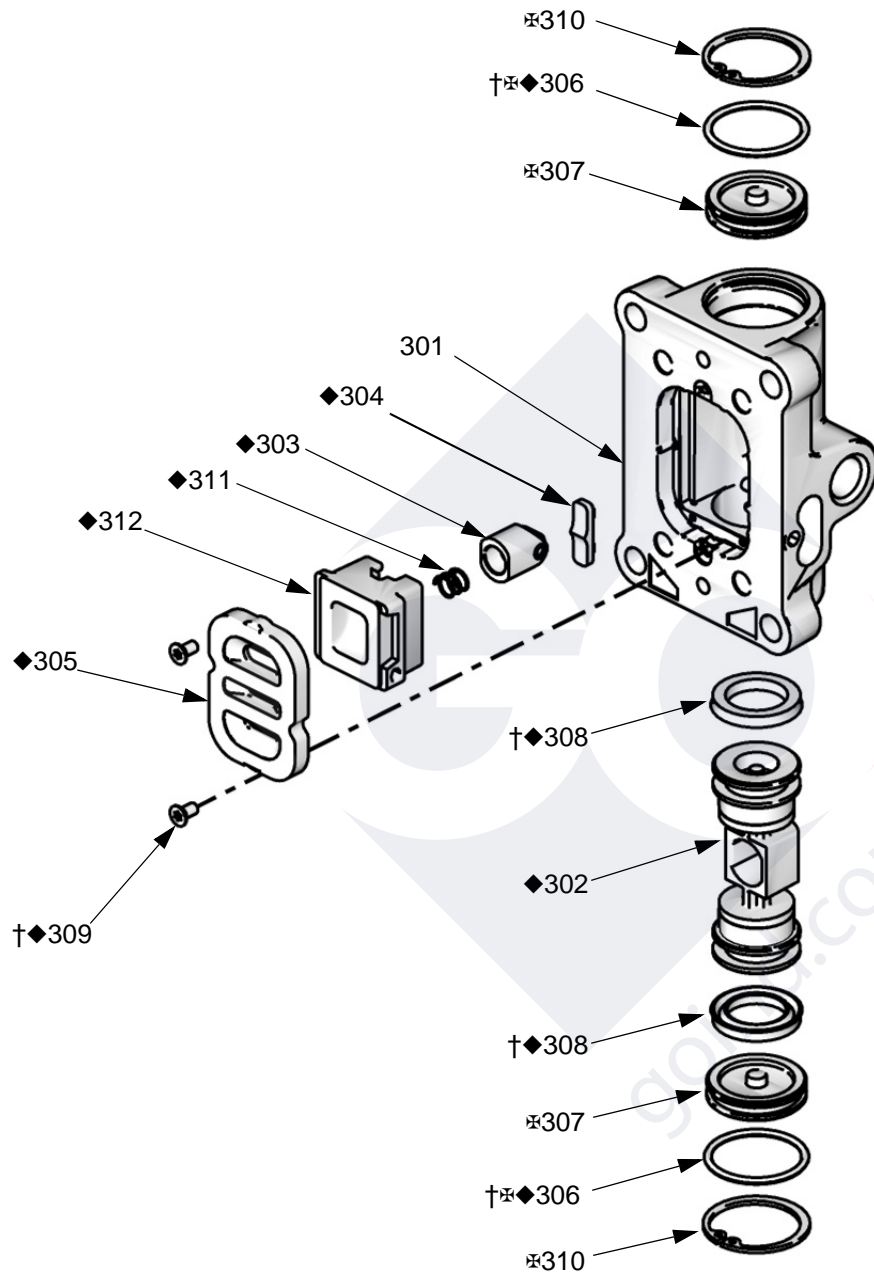

ti16213a

Pneumatic Valve Parts

Complete Pneumatic Valve Replacement Kit 24A351

To replace the complete pneumatic valve, order Pneumatic Valve Replacement Kit 24A351 (2.5 in., 3.5 in.) or Kit 24A352 (4.5 in.). The kit includes items 301-312 below, and items 209 and 211 on page 37.

Pneumatic Valve Repair Kits

Pneumatic valve parts are not sold individually. The table below shows possible kit options for each part.

Ref.	Description	Qty.	Pneumatic Valve Repair Kit 24A537 (2.5 in., 3.5 in.) 24A538 (4.5 in.)	Pneumatic Valve Seal Kit 24A535 (2.5 in., 3.5 in.) 24A536 (4.5in.)	Pneumatic Valve End Cap Kit 24A360 (2.5 in., 3.5 in.) 24A361 (4.5 in.)
301	HOUSING	1			
302◆	PNEUMATIC VALVE PISTON	1	✓		
303◆	DETENT PISTON ASSEMBLY	1	✓		
304◆	DETENT CAM	1	✓		
305◆	PLATE, pneumatic valve	1	✓		
306†⊕◆	O-RING	2	✓	✓	✓
307⊕	CAP	2			✓
308†◆	U-CUP	2	✓	✓	
309†◆	SCREW	2	✓	✓	
310⊕	SNAP RING	2	✓		✓
311◆	DETENT SPRING	1	✓		
312◆	CUP	1	✓		

† Included in Pneumatic Valve Seal Kit 24A535.

◆ Included in Pneumatic Valve Repair Kit 24A537.

⊕ Included in Pneumatic Valve End Cap Kit 24A360.

Replacement screws (309) are available in a pack of 10. Order Kit 24A359.

Kits and Accessories

Additional Kits & Accessories

Part No.	Description
B32045	225-750 PSI Pressure Relief Valve Kit (Adjustable)
B32046	750-1500 PSI Pressure Relief Valve Kit (Adjustable)
B32047	1500-2250 PSI Pressure Relief Valve Kit (Adjustable)
B32048	2250-3000 PSI Pressure Relief Valve Kit (Adjustable)
B32049	3000-4000 PSI Pressure Relief Valve Kit (Adjustable)
B32050	4000-5000 PSI Pressure Relief Valve Kit (Adjustable)
B32051	5000-6000 PSI Pressure Relief Valve Kit (Adjustable)
B32088	SST Calibration Column Kit
B32089	SST Manifold Assembly Kit
B32157	316 SST Ball Valve Kit, 3/4 in. NPT(F)
B32158	Fluid Filter 6000 PSI
B32159	Fluid Filter 10000 PSI
B32162	1/4 in. NPT(F) X 1/4 in. NPT(F) Check Kit
237212	Pneumatic Lubricator

AFLAS Air Motor Upgrade Kits	
Part No.	Description
B33067*	2.5" AFLAS air motor upgrade
B33068*	3.5" AFLAS air motor upgrade
B33069*	4.5" AFLAS air motor upgrade

* Includes ref. 204, 207, 308, and 311.

Dimensions

Python XL-DA Pump Dimensions

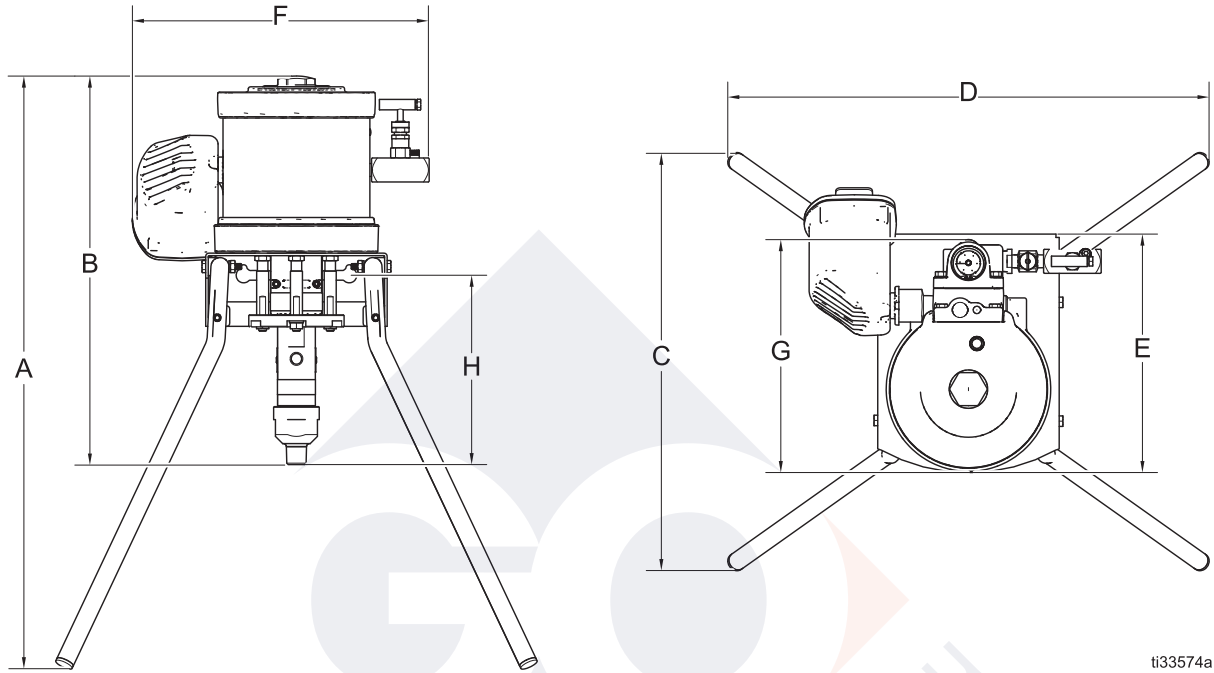

ti33574a

FIG. 22 Python Pump Dimensions

Size	A	B	C	D	E	F	G	H
250	24.0 in. (61.0 cm)	14.5 in. (36.8 cm)	16.75 in. (42.5 cm)	17.75 in. (45.1 cm)	8.0 in. (20.3 cm)	7.62 in. (19.4 cm)	6.0 in. (15.2 cm)	9.8 in. (24.8 cm)
350	24.0 in. (61.0 cm)	14.5 in. (36.8 cm)	16.75 in. (42.5 cm)	17.75 in. (45.1 cm)	8.0 in. (20.3 cm)	3.62 in. (9.2 cm)	7.70 in. (19.6 cm)	9.8 in. (24.8 cm)
450	24.0 in. (61.0 cm)	14.5 in. (36.8 cm)	16.75 in. (42.5 cm)	19.25 in. (48.9 cm)	9.94 in. (25.5 cm)	13.16 in. (33.4 cm)	9.19 in. (23.3 cm)	9.8 in. (24.8 cm)

Wall Bracket Mounting Hole Diagram

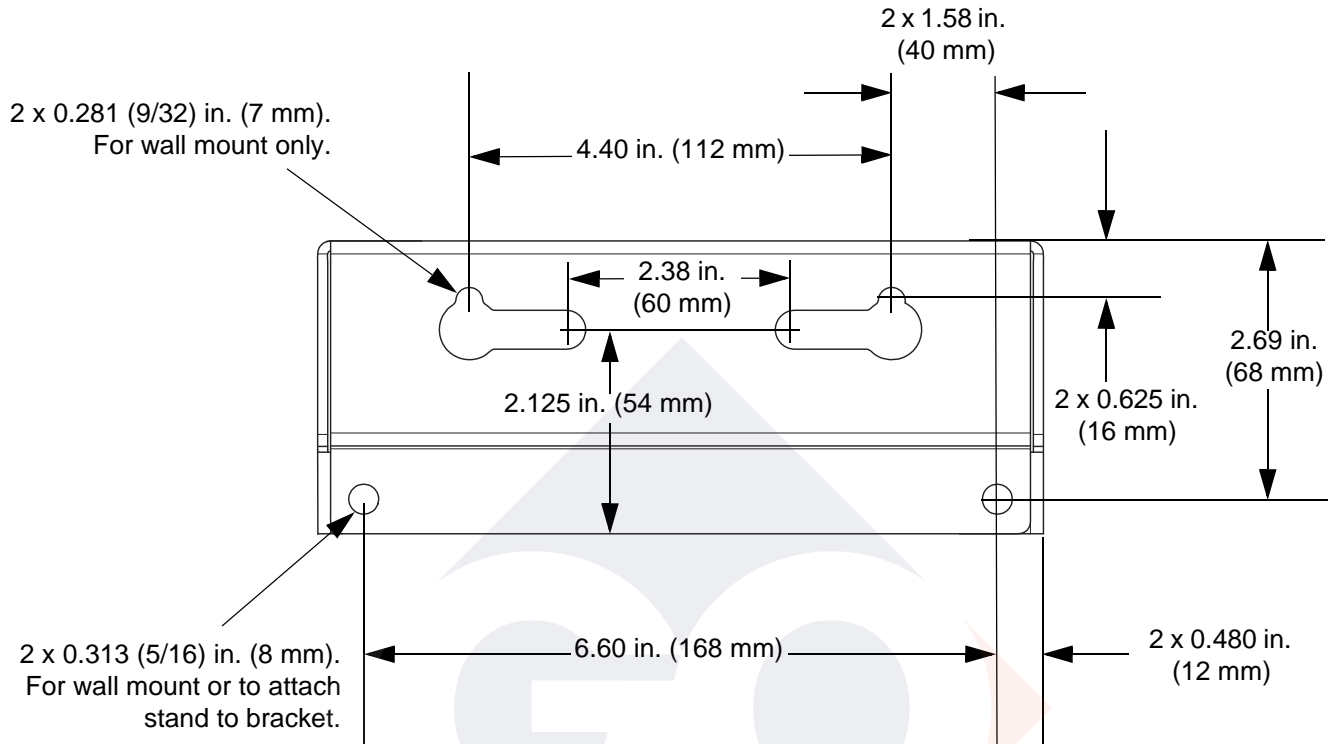

TI33575a

Performance Charts

2.5 in. Motors

3/8 in. Plunger (PCI-0250-038)

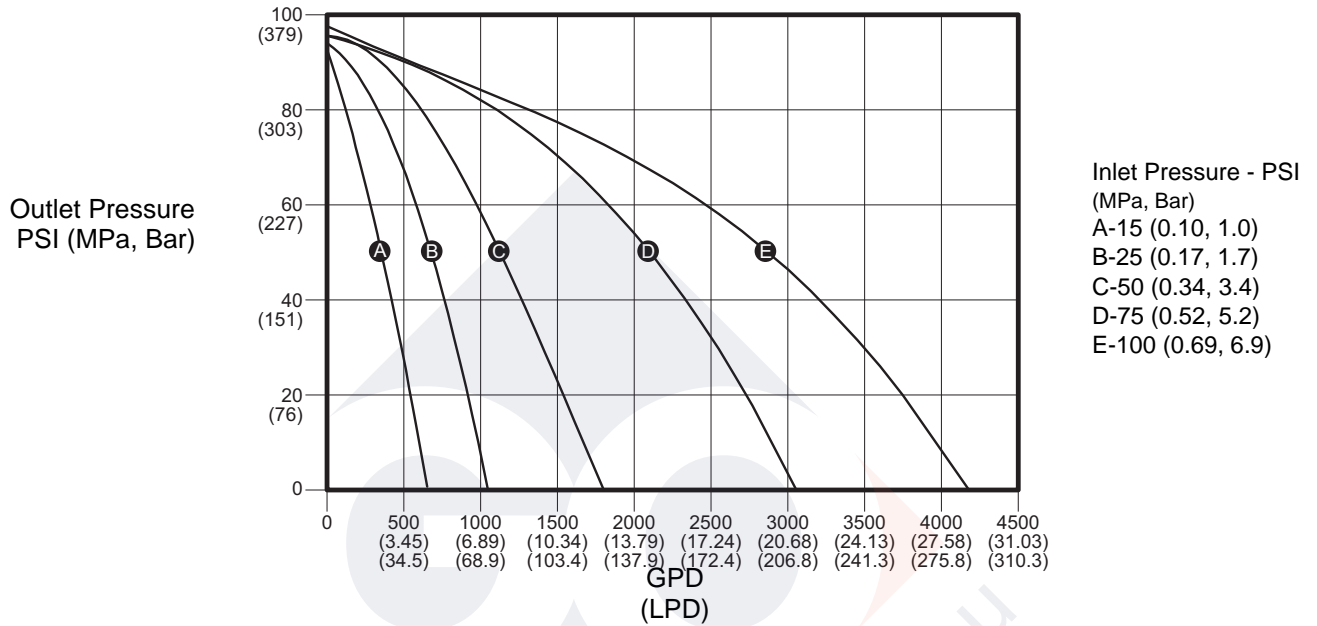

FIG. 23

1/2 in. Plunger (PCI-0250-050)

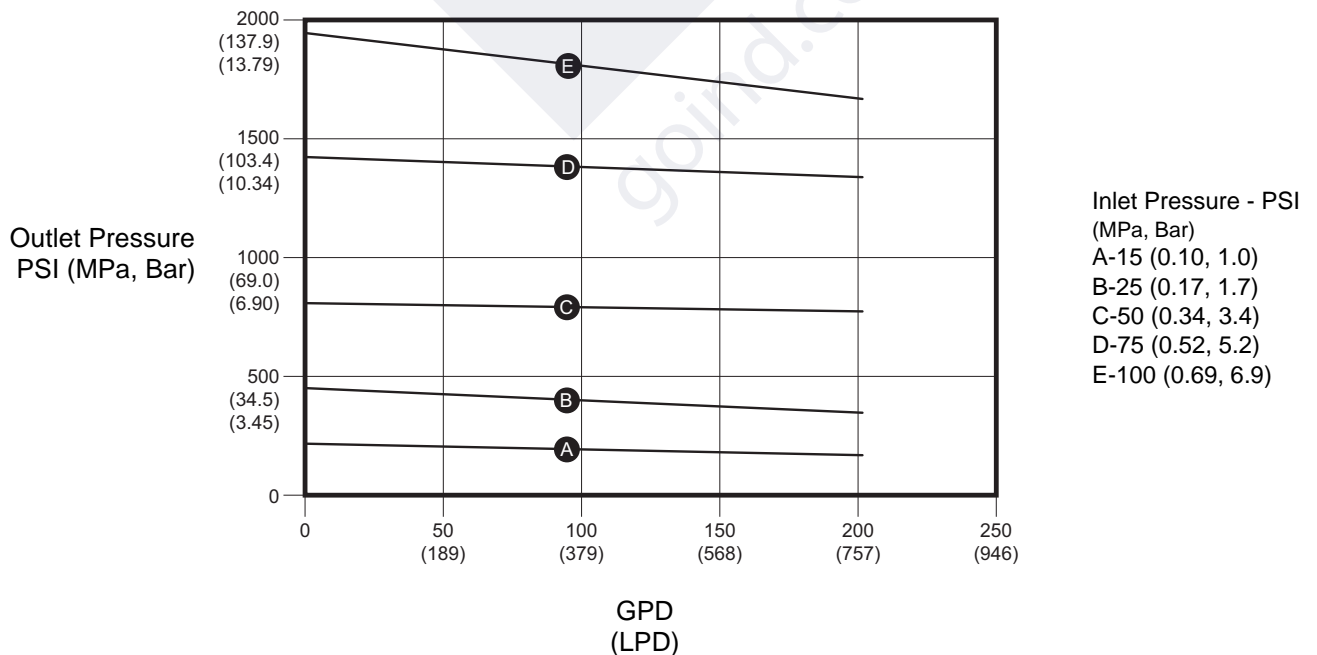

FIG. 24

3/4 in. Plunger (PCI-0250-075)

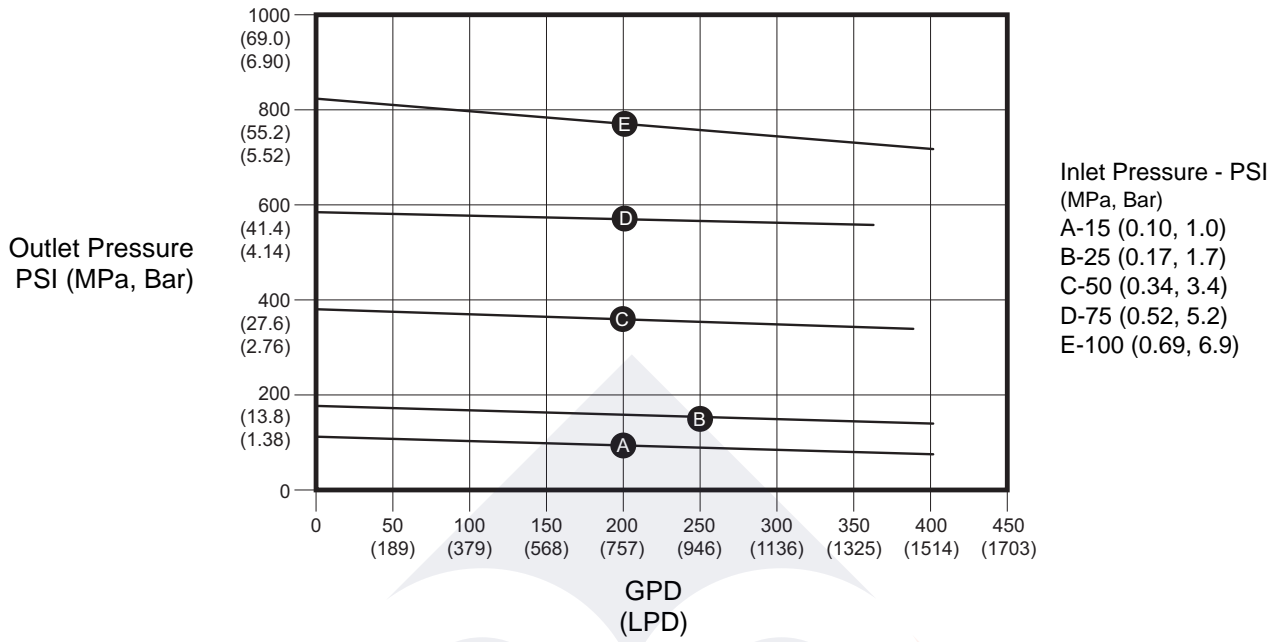

FIG. 25

3.5 in. Motors

1/2 in. Plunger (PCI-0350-050)

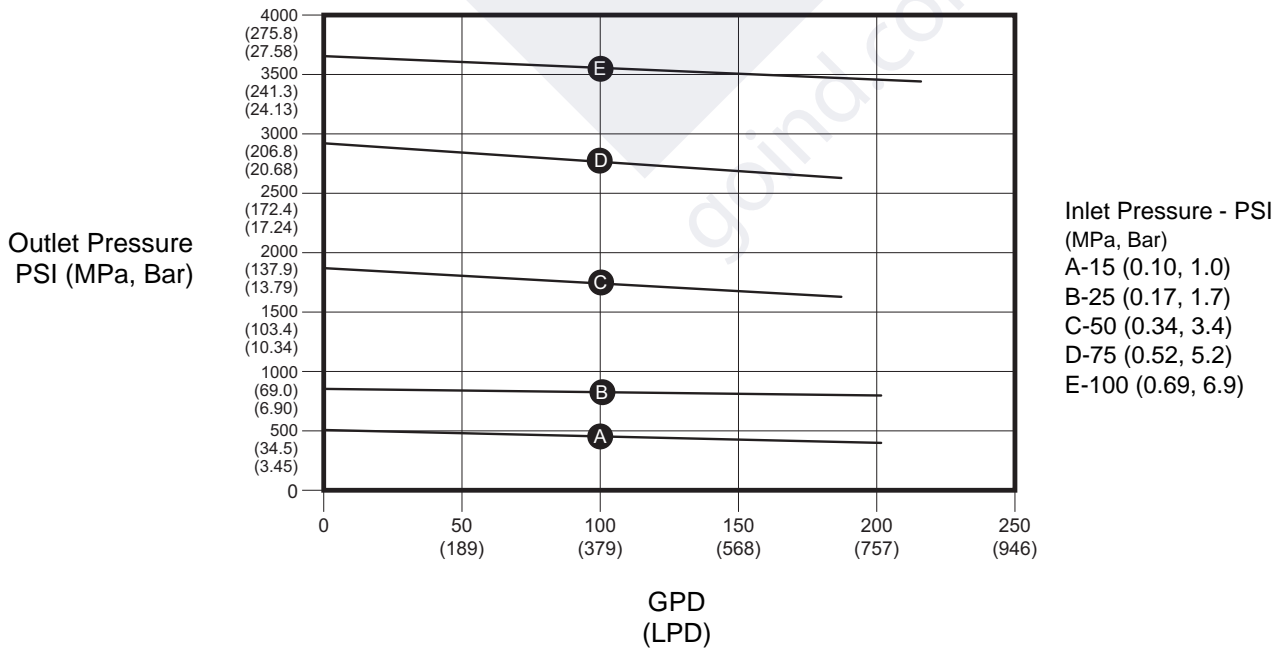

FIG. 26

3/4 in. Plunger (PCI-0350-075)

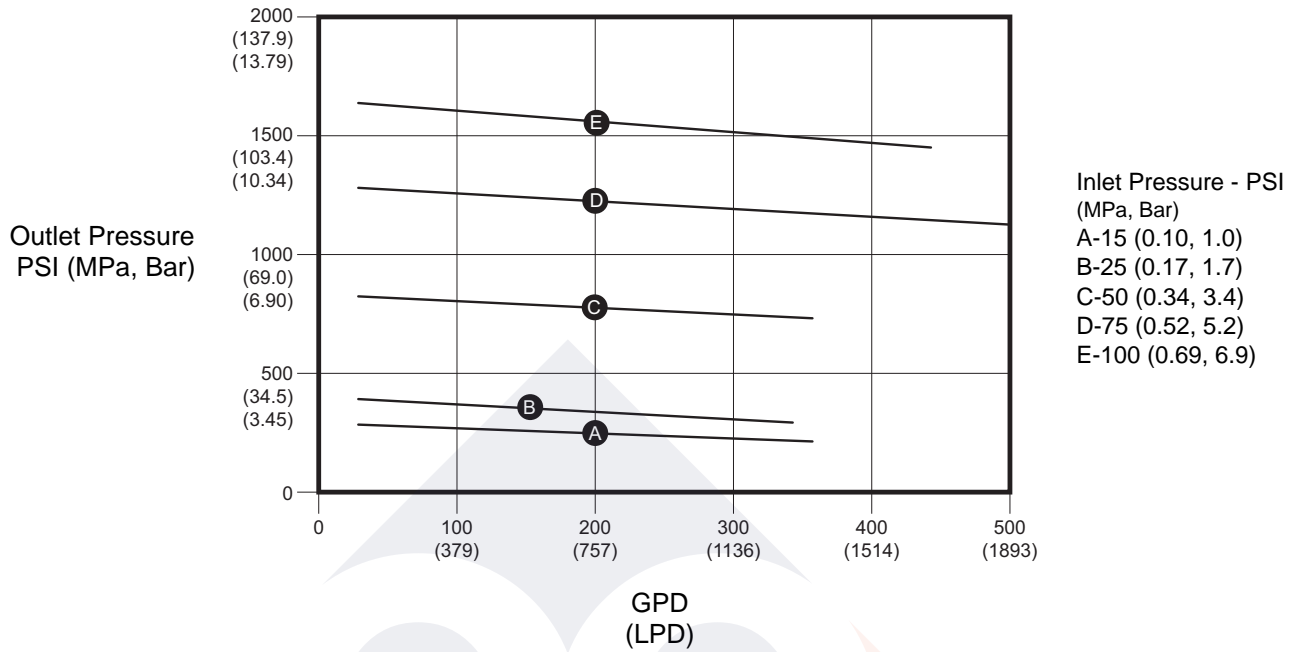

FIG. 27

1 in. Plunger (PCI-0350-100)

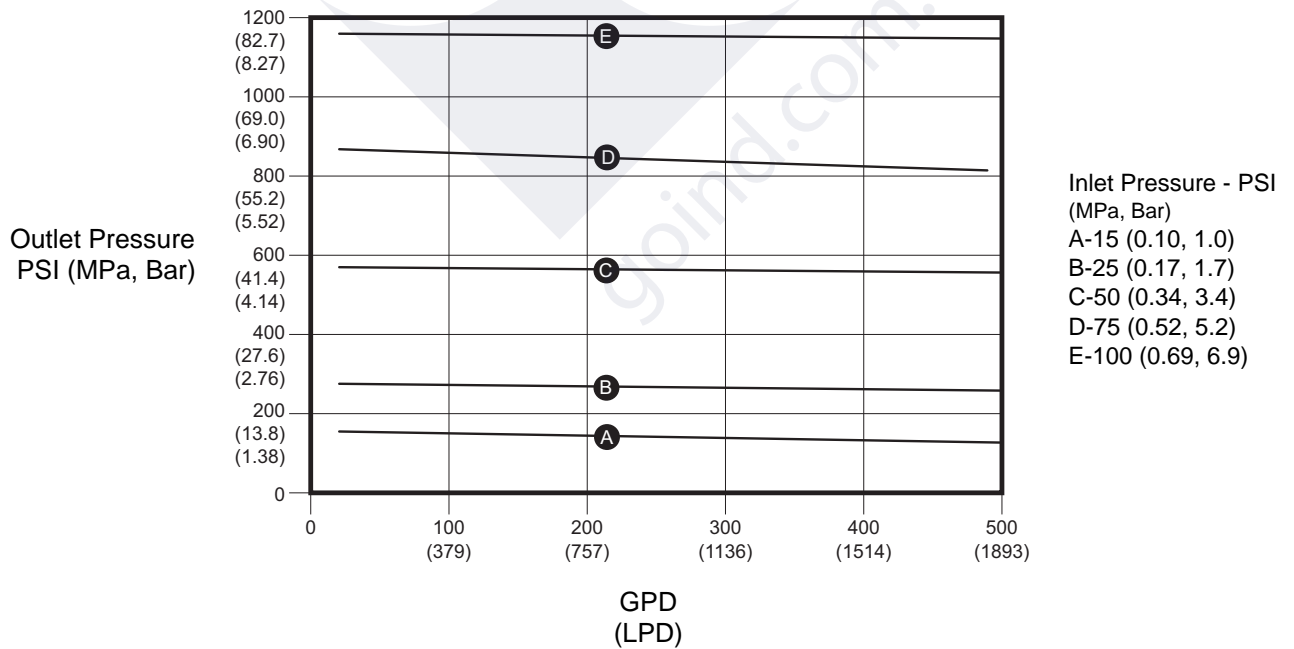

FIG. 28

4.5 in. Motors

1/2 in. Plunger (PCI-0450-050)

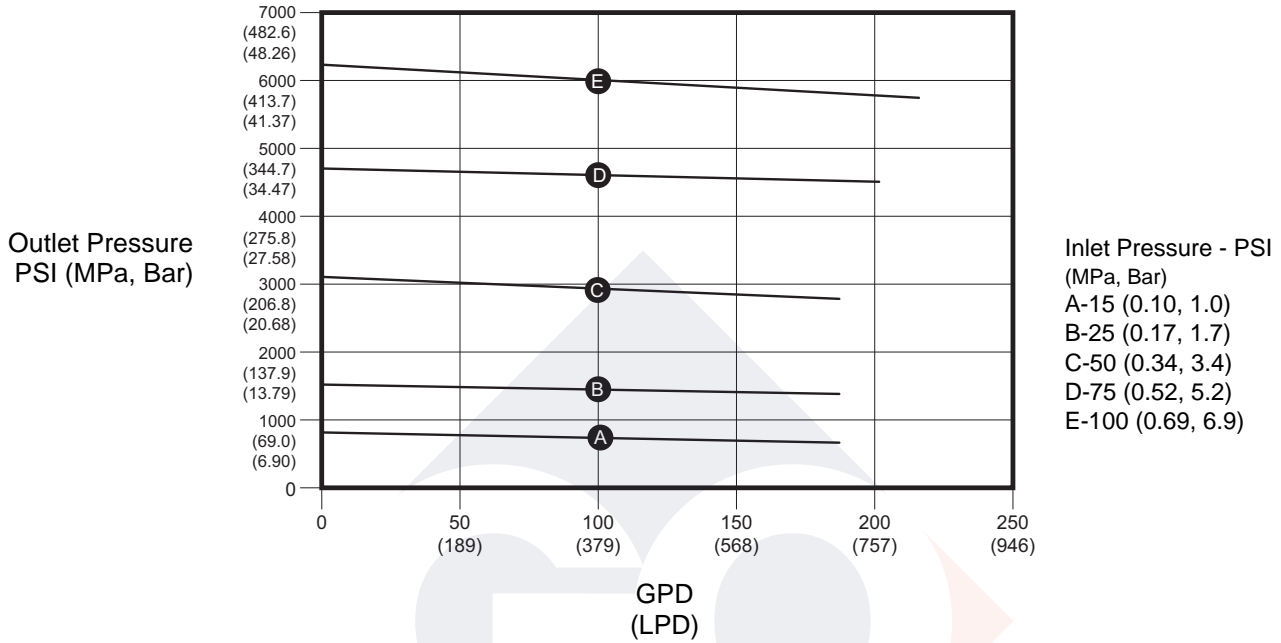

FIG. 29

3/4 in. Plunger (PCI-0450-075)

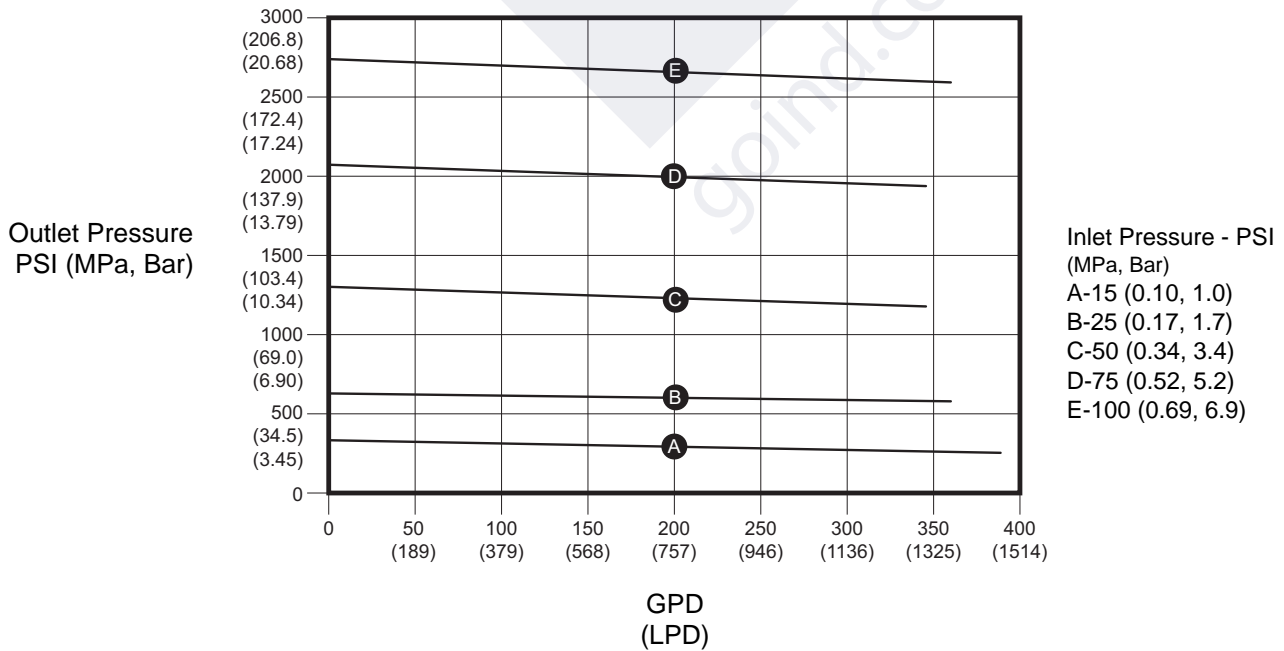

FIG. 30

1 in. Plunger (PCI-0450-100)

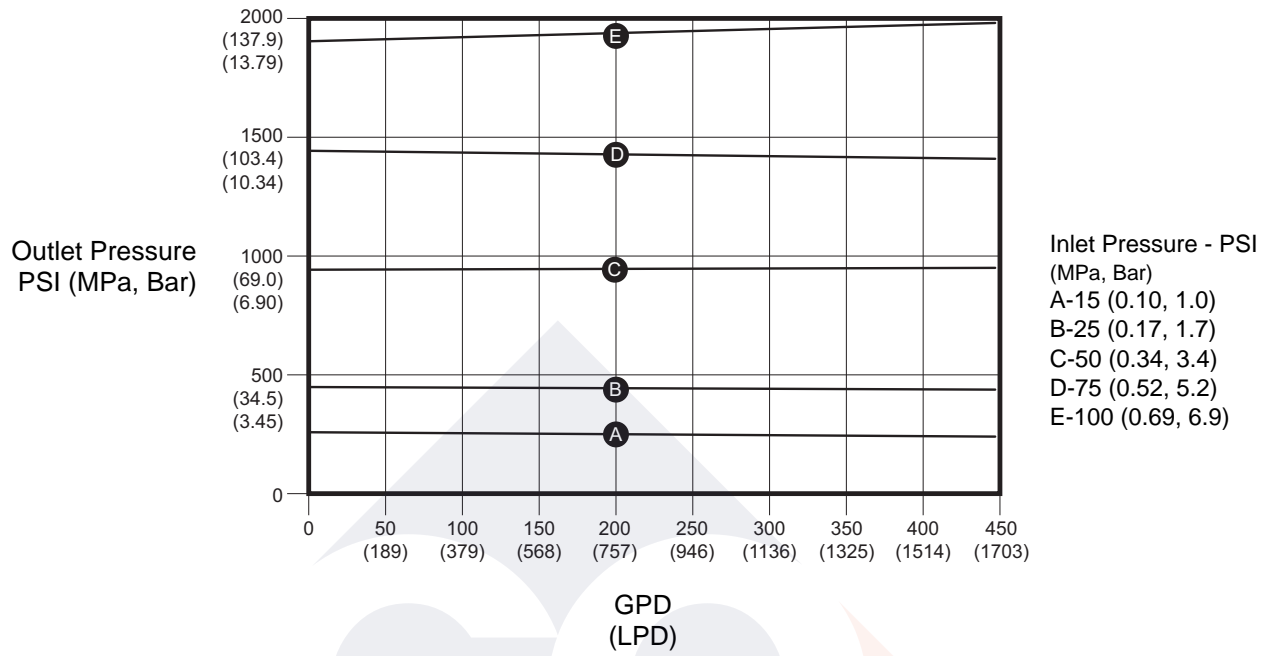

FIG. 31

Air Consumption

The air consumption rate depends on the cycle rate of the pump. To estimate your cycle rate, see the **Baseline Chemical Dosage Settings**, page 16, and the **Performance Charts**, starting on page 43.

2.5 in. Motor					
Air Consumption					
SCFM (SM ³ /hr)					
CPM	15 PSI	25 PSI	50 PSI	75 PSI	100 PSI
10	0.3 (0.5)	0.4 (0.4)	0.6 (1.0)	0.8 (1.4)	1.1 (1.8)
20	0.6 (0.9)	0.7 (1.2)	1.2 (2.3)	1.7 (2.8)	2.1 (3.6)
30	0.8 (1.1)	1.1 (1.9)	1.8 (3.0)	2.5 (4.2)	3.2 (5.4)
40	1.1 (1.9)	1.5 (2.5)	2.4 (4.1)	3.3 (5.6)	4.3 (7.2)
50	1.4 (2.4)	1.8 (3.1)	3.0 (5.1)	4.2 (7.1)	5.3 (9.0)
60	1.7 (2.8)	2.2 (3.7)	3.6 (6.1)	5.0 (8.5)	6.4 (10.9)

3.5 in. Motor					
Air Consumption					
SCFM (SM ³ /hr)					
CPM	15 PSI	25 PSI	50 PSI	75 PSI	100 PSI
10	0.3 (0.5)	0.4 (0.7)	0.7 (1.2)	1.0 (1.6)	1.2 (2.1)
20	0.6 (1.1)	0.8 (1.4)	1.4 (2.3)	1.9 (3.3)	2.5 (4.2)
30	1.0 (1.6)	1.3 (2.2)	2.1 (3.5)	2.9 (4.9)	3.7 (6.3)
40	1.3 (2.2)	1.7 (2.9)	2.8 (4.7)	3.8 (6.5)	4.9 (8.4)
50	1.6 (2.7)	2.1 (3.6)	3.5 (5.9)	4.8 (8.2)	6.2 (10.4)
60	1.9 (3.3)	2.5 (4.2)	4.1 (7.0)	5.8 (9.8)	7.4 (12.5)

4.5 in. Motor					
Air Consumption					
SCFM (SM ³ /hr)					
CPM	15 PSI	25 PSI	50 PSI	75 PSI	100 PSI
10	0.5 (0.9)	0.7 (1.2)	1.1 (1.9)	1.6 (2.7)	2.0 (3.5)
20	1.1 (1.8)	1.4 (2.4)	2.3 (3.9)	3.2 (5.4)	4.1 (6.9)
30	1.6 (2.7)	2.1 (3.5)	3.4 (5.8)	4.8 (8.1)	6.1 (10.4)
40	2.1 (3.6)	2.8 (4.7)	4.6 (7.8)	6.3 (10.8)	8.1 (13.8)
50	2.6 (4.5)	3.5 (5.9)	5.7 (9.7)	7.9 (13.5)	10.2 (17.3)
60	3.2 (5.4)	4.2 (7.1)	6.8 (11.6)	9.5 (16.2)	12.2 (20.7)

All written and visual data contained in this document reflects the latest product information available at the time of publication. Graco reserves the right to make changes at any time without notice.

Original instructions. This manual contains English. MM 3A5938

Graco Headquarters: Minneapolis

International Offices: Belgium, China, Japan, Korea

GRACO INC. AND SUBSIDIARIES • P.O. BOX 1441 • MINNEAPOLIS MN 55440-1441 • USA
Copyright 2018, Graco Inc. All Graco manufacturing locations are registered to ISO 9001.

www.graco.com

Revision F, May 2020

Technical Data

Python XL-DA Chemical Injection Pump		
.....	US	Metric
Maximum pneumatic inlet pressure	See Models on page 3.	
Maximum fluid working pressure	See Models on page 3.	
Maximum cycle rate	60 cpm	
Environmental temperature range	-40° – 176°F	-40° – 80°C
Noise (dBa)		
2.5 in. Air Motor Sound Power*	83.2 dBA	
2.5 in. Air Motor Sound Pressure**	76.5 dBA	
3.5 in. Air Motor Sound Power*	84.5 dBA	
3.5 in. Air Motor Sound Pressure**	77.9 dBA	
4.5 in. Air Motor Sound Power*	80.1 dBA	
4.5 in. Air Motor Sound Pressure**	70.2 dBA	
Inlet/Outlet Sizes		
Fluid inlet size (3/8 in. & 1/2 in. plunger)	1/2 in. npt(m)	
Fluid inlet size (3/4 in. plunger)	3/4 in. npt(m)	
Fluid inlet size (1 in. plunger)	1 in. npt(m)	
Fluid outlet size (3/8 in., 1/2 in., & 3/4 in. plungers)	1/4 in. npt(f)	
Fluid outlet size (1 in. plunger)	1/2 in. npt(f)	
Pneumatic inlet size	1/4 in. npt(f)	
Exhaust fitting size	3/8 in. npt(f)	
Materials of Construction		
Pump/Check Valve Seal Material	See Configuration Number Matrix on page 5 for seal material. All other packing materials are PEEK and PTFE unless otherwise noted.	
Wetted Parts	See Configuration Number Matrix on page 5 for plunger material. All other packing materials are 316 stainless steel unless otherwise noted.	
Weight		
2.5 in. (ALL MODELS)	24.0 lbs.	10.9 kg
3.5 in. (ALL MODELS)	29.5 lbs.	13.4 kg
4.5 in. (ALL MODELS)	34.0 lbs.	15.4 kg

* Sound Power at 70 psi (0.48 MPa, 4.8 bar), 80 cpm. Sound power measured per ISO-9614-2.

** Sound Pressure was test 3.28 feet (1 m) from equipment.

California Proposition 65

CALIFORNIA RESIDENTS

 **WARNING:** Cancer and reproductive harm. – www.P65warnings.ca.gov.

Graco Standard Warranty

Graco warrants all equipment referenced in this document which is manufactured by Graco and bearing its name to be free from defects in material and workmanship on the date of sale to the original purchaser for use. With the exception of any special, extended, or limited warranty published by Graco, Graco will, for a period of twelve months from the date of sale, repair or replace any part of the equipment determined by Graco to be defective. This warranty applies only when the equipment is installed, operated and maintained in accordance with Graco's written recommendations.

This warranty does not cover, and Graco shall not be liable for general wear and tear, or any malfunction, damage or wear caused by faulty installation, misapplication, abrasion, corrosion, inadequate or improper maintenance, negligence, accident, tampering, or substitution of non-Graco component parts. Nor shall Graco be liable for malfunction, damage or wear caused by the incompatibility of Graco equipment with structures, accessories, equipment or materials not supplied by Graco, or the improper design, manufacture, installation, operation or maintenance of structures, accessories, equipment or materials not supplied by Graco.

This warranty is conditioned upon the prepaid return of the equipment claimed to be defective to an authorized Graco distributor for verification of the claimed defect. If the claimed defect is verified, Graco will repair or replace free of charge any defective parts. The equipment will be returned to the original purchaser transportation prepaid. If inspection of the equipment does not disclose any defect in material or workmanship, repairs will be made at a reasonable charge, which charges may include the costs of parts, labor, and transportation.

THIS WARRANTY IS EXCLUSIVE, AND IS IN LIEU OF ANY OTHER WARRANTIES, EXPRESS OR IMPLIED, INCLUDING BUT NOT LIMITED TO WARRANTY OF MERCHANTABILITY OR WARRANTY OF FITNESS FOR A PARTICULAR PURPOSE.

Graco's sole obligation and buyer's sole remedy for any breach of warranty shall be as set forth above. The buyer agrees that no other remedy (including, but not limited to, incidental or consequential damages for lost profits, lost sales, injury to person or property, or any other incidental or consequential loss) shall be available. Any action for breach of warranty must be brought within two (2) years of the date of sale.

GRACO MAKES NO WARRANTY, AND DISCLAIMS ALL IMPLIED WARRANTIES OF MERCHANTABILITY AND FITNESS FOR A PARTICULAR PURPOSE, IN CONNECTION WITH ACCESSORIES, EQUIPMENT, MATERIALS OR COMPONENTS SOLD BUT NOT MANUFACTURED BY GRACO. These items sold, but not manufactured by Graco (such as electric motors, switches, hose, etc.), are subject to the warranty, if any, of their manufacturer. Graco will provide purchaser with reasonable assistance in making any claim for breach of these warranties.

In no event will Graco be liable for indirect, incidental, special or consequential damages resulting from Graco supplying equipment hereunder, or the furnishing, performance, or use of any products or other goods sold hereto, whether due to a breach of contract, breach of warranty, the negligence of Graco, or otherwise.

FOR GRACO CANADA CUSTOMERS

The Parties acknowledge that they have required that the present document, as well as all documents, notices and legal proceedings entered into, given or instituted pursuant hereto or relating directly or indirectly hereto, be drawn up in English. Les parties reconnaissent avoir convenu que la rédaction du présente document sera en Anglais, ainsi que tous documents, avis et procédures judiciaires exécutés, donnés ou intentés, à la suite de ou en rapport, directement ou indirectement, avec les procédures concernées.

Graco Information

For the latest information about Graco products, visit www.graco.com.

For patent information, see www.graco.com/patents.

TO PLACE AN ORDER, contact your Graco distributor or call to identify the nearest distributor.

Phone: 612-623-6921 **or Toll Free:** 1-800-328-0211 **Fax:** 612-378-3505

All written and visual data contained in this document reflects the latest product information available at the time of publication. Graco reserves the right to make changes at any time without notice.

Original instructions. This manual contains English. MM 3A5938

Graco Headquarters: Minneapolis

International Offices: Belgium, China, Japan, Korea

GRACO INC. AND SUBSIDIARIES • P.O. BOX 1441 • MINNEAPOLIS MN 55440-1441 • USA
Copyright 2018, Graco Inc. All Graco manufacturing locations are registered to ISO 9001.

www.graco.com
Revision F, May 2020