

**7 Year  
Warranty!**

## Safe, Versatile Powered Hose Reels

We like to think of the XD motor rewind reels as super-powered. The innovative design is packed with features to help you work safer, smarter and faster. We demand extensive product testing, often exceeding industry standards to ensure you get the best product on the market.

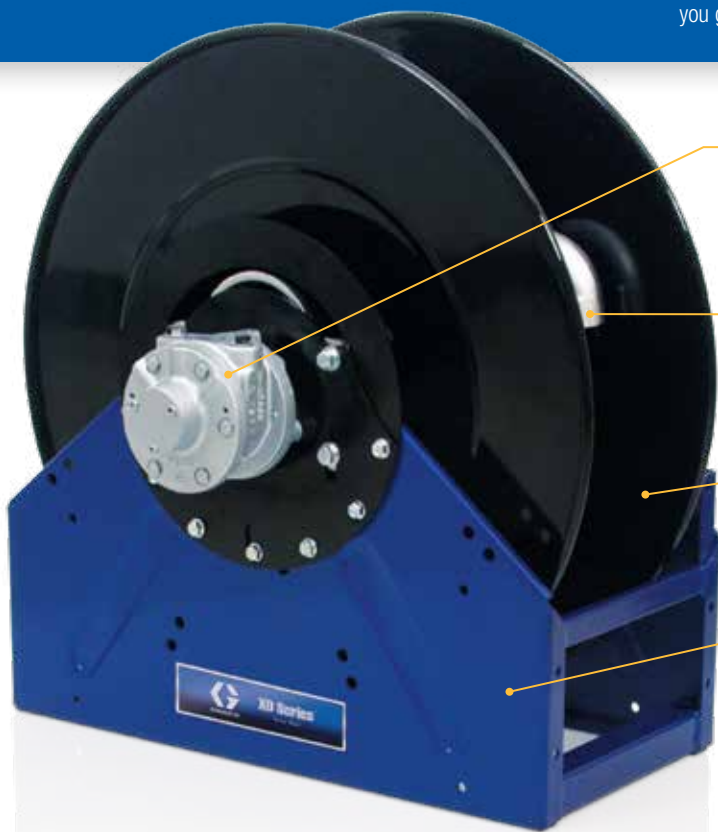

### Safe, Reliable Direct Drive and Gear Motors

Drive unit is clean and lubricated for life. No need to worry about greasy, exposed drive chains that need maintenance and can be dangerous to operators.

### Easy System Integration

Easily change the inlet and motor direction to give you the option of a right- or left-hand flow orientation.

### Heavy-duty Welded Spool

Built to handle the weight of heavy hoses. Designed to surround and protect the drive unit from the elements to promote longer-lasting, safer operation.

### Rugged and Durable Body

Heavy-duty one piece welded frame is engineered to flex under extreme operating conditions and is stronger than bolted frames that can loosen with use. Individually painted and powder-coated components have superior corrosion resistance over assembled and painted products.

### Typical Applications

- Heavy-duty truck dealers
- Fleet maintenance
- Mining maintenance
- Public works garages
- Construction vehicle maintenance
- Heavy-duty mobile service trucks
- Agriculture
- Lube trucks

### Typical Fluids Handled

- Petroleum- and synthetic-based oils (motor, gear and ATF)
- Diesel fuel
- Air
- Water
- Grease
- Waste oil evacuation

### Technical Specifications

Operating Temperature Range	
Motorless Reels	-40°F to 180°F (-40°C to 82°C)
Air/Water Applications	-40°F to 180°F (-40°C to 82°C)
Waste Oil Evacuation Applications	-40°F to 180°F (-40°C to 82°C)
Oil Applications	-40°F to 180°F (-40°C to 82°C)
Grease Applications	0°F to 180°F (-18°C to 82°C)
Diesel Fuel Applications	-40°F to 140°F (-40°C to 60°C)
Wetted Parts	Nickel plated cast iron, cast iron, Buna-N rubber, polyethylene
Electric and Hydraulic Motors Sound Pressure Level	<80 dB(A)
Pneumatic Motors Sound Pressure Level	84.6 dB(A)
Pneumatic Motors Sound Power Level	89.9 dB(A)
Instruction Manual	332630

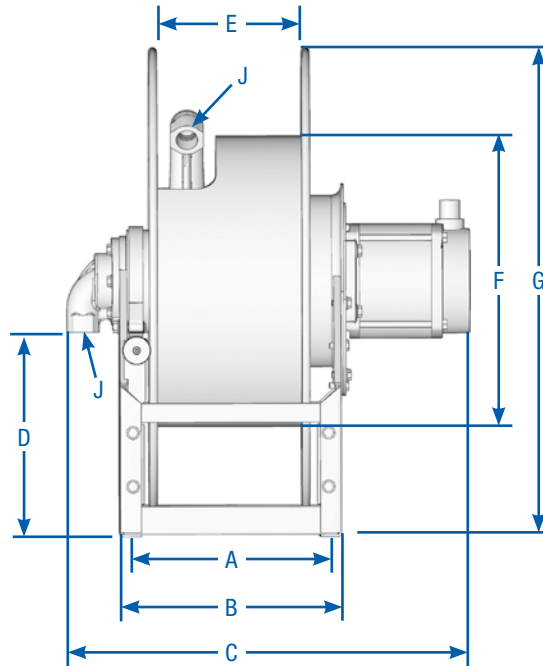

## Dimensions

Reference dimension "D" for specific motor type

Model	Inlet/Outlet Size (J) NPT(F)	Dimensions in (mm)								
		A (Mounting Holes)	B	C			D	E	F	G
				Pneumatic	Hydraulic	Electric				
XD 6010	1 in/1 in	10.45 (256)	11.8 (300)	20.4 (519)	15.7 (400)	21.6 (547)	10.9 (277)	7.8 (198)	15.5 (394)	26.1 (663)
XD 7010	1 in/1 in	12.95 (329)	14.3 (363)	22.9 (583)	18.2 (463)	24.1 (611)	10.9 (277)	10 (254)	10 (254)	26.1 (663)
XD 7015	1-1/2 in/1-1/2 in	12.95 (329)	14.3 (363)	23.7 (603)	19 (483)	24.8 (631)	10.9 (277)	10 (254)	10 (254)	26.1 (663)
XD 7020	2 in/2 in	12.95 (329)	14.3 (363)	24.1 (613)	19.4 (493)	25.2 (641)	10.2 (259)	10 (254)	10 (254)	26.1 (663)
XD 8010	1 in/1 in	20.68 (525)	22.1 (561)	30.7 (779)	26 (659)	31.8 (807)	13.4 (340)	18 (457)	15.5 (394)	30.1 (765)
XD 8015	1-1/2 in/1-1/2 in	20.68 (525)	22.1 (561)	31.4 (799)	26.7 (679)	32.5 (827)	13.4 (340)	18 (457)	15.5 (394)	30.1 (765)
XD 8020	2 in/2 in	20.68 (525)	22.1 (561)	31.9 (809)	27.1 (689)	33 (837)	12.7 (323)	18 (457)	15.5 (394)	30.1 (765)

## Typical Mounting Configurations

**Bench/Trunk Mount**

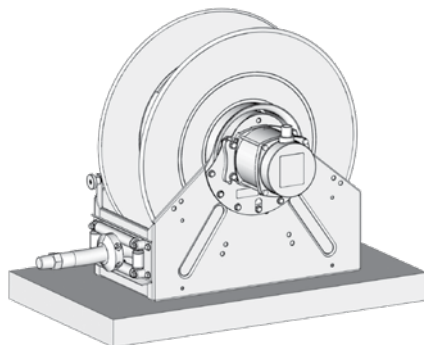

**Truck Mount with Remote Mounted Roller Guide**

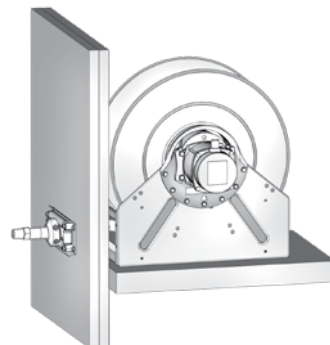

## How to Select an XD Powered Bare Hose Reel

### A Complete Family of Motor Rewind Hose Reels

The innovative design of the XD reel family is packed with features to help you work safer, smarter and faster. Direct-drive motor options include hydraulic, pneumatic and electric for air, water, oil, grease, fuel dispense and waste oil evacuation applications. Use this selection chart to configure the XD reel to suit your needs.

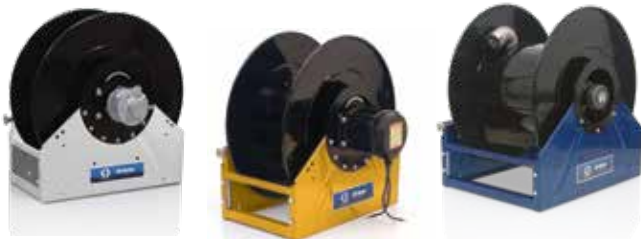

Hose and Cord Reels

**A**

#### Specify the Hose Fluid Type and Capacity

Determine your fluid type and capacity before selecting your reel.

REQUIRED

Fluid Type	Hose ID in (mm)	Hose Length ft (m)
<input type="checkbox"/> Air/Water	<input type="checkbox"/> 1/2 (13)	<input type="checkbox"/> 50 (15)
<input type="checkbox"/> Antifreeze	<input type="checkbox"/> 1 (25)	<input type="checkbox"/> 75 (23)
<input type="checkbox"/> Petroleum- and Synthetic-Based Oils	<input type="checkbox"/> 1-1/2 (38)	<input type="checkbox"/> 100 (30)
<input type="checkbox"/> Waste Oil	<input type="checkbox"/> 2 (51)	<input type="checkbox"/> 150 (46)
<input type="checkbox"/> Diesel Fuel		

**B**

#### Choose Your Reel Size

- XD 60    XD 70    XD 80

**C**

#### Choose Your Reel Color

Select from Blue, Yellow or White.

- Blue    Yellow    White

**D**

#### Select Your Drive Type and Frame

Reels can be ordered with a motor or without. If you choose a model without a motor, you must purchase the motor separately.

REQUIRED

- Order Reel with Motor Included (Pages 254-256)
- Order Reel and Motor Separately (Page 257)
  - Pneumatic Motor
  - Hydraulic Motor
  - Electric Motor
    - 12 VDC, 1/2 HP    24 VDC, 2/3 HP
    - 12 VDC, 2/3 HP    115 VAC, 0.40 HP
    - 24 VDC, 1/2 HP

**E**

#### Choose Your Controls (Pages 258)

REQUIRED

- Pneumatic Motor**
  - Pneumatic 2-position, 3-way valve
- Hydraulic Motor**
  - 12 VDC electric control of hydraulic motor, 3-position, 4-way valve
  - 12 VDC electric control of hydraulic motor with switch, 3-position, 4-way valve
  - 24 VDC electric control of hydraulic motor, 3-position, 4-way valve
  - 24 VDC electric control of hydraulic motor with switch, 3-position, 4-way valve
- Electric Motor**
  - Hazardous location on/off button
  - 12 VDC intermittent-duty solenoid
  - 24 VDC intermittent-duty solenoid
  - Manual reset button circuit breaker (25 or 50 amp)

**F**

REQUIRED FOR INSTALLATION

#### Hose Inlet Kit (Page 259)

A hose inlet is required for installation. They are appropriately sized for the hose reels based on type of fluid, hose size and pressure.

Note: All 1-1/2 in (38 mm) hose reels include a 2 in (51 mm) Victaulic-style groove on inlet. If you are using these reels, it is recommended to order an inlet kit from Graco.

- Yes (required for installation)
- No (will supply my own hose inlet kit)

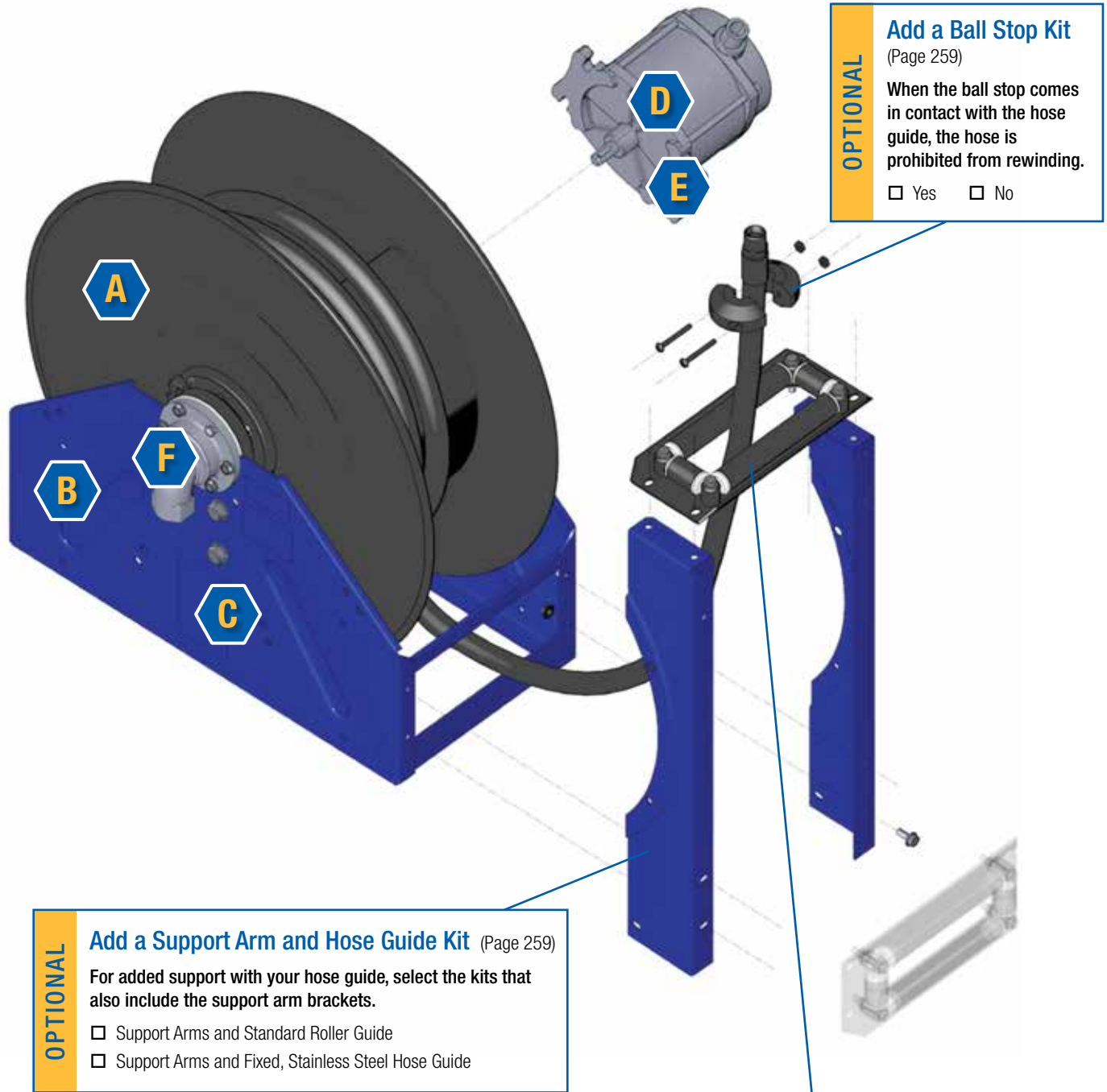

**OPTIONAL**

**Add a Ball Stop Kit**  
(Page 259)

When the ball stop comes in contact with the hose guide, the hose is prohibited from rewinding.

Yes    No

**OPTIONAL**

**Add a Support Arm and Hose Guide Kit** (Page 259)

For added support with your hose guide, select the kits that also include the support arm brackets.

Support Arms and Standard Roller Guide  
 Support Arms and Fixed, Stainless Steel Hose Guide

**OPTIONAL**

**Add a Hose Guide Kit** (Page 259)

Select between a fixed, stainless steel hose guide or a general roller guide.

Hose guide mounts directly to the reel frame or in three different positions on the support arm.

Standard Roller Guide  
 Fixed, Stainless Steel Hose Guide

# XD Series Bare Hose Reels



60 / 70 / 80

## Ordering Information

### Reel with Motor – 1 in (25 mm) Inlet/Outlet

#### XD 60 Reels

Reel Size	Fluid	Motor	Hose Capacity of Reel ft (m)			Maximum Pressure psi (bar)	Weight lb (kg)	Inlet/Outlet Size NPT(F)	Reel Part Number by Color			Hose Accessories (Must be ordered separately)			
			Hose ID in (mm)						Metallic Blue	Yellow	White	Hose Inlet Kit	Hose		
			1/2 (13)	3/4 (19)	1 (25)										
XD 6010	Air/ Water	Pneumatic	100 (30)	100 (30)	50 (15)	600 (41)	123 (56)	1 in/1 in (25 mm/ 25 mm)	24R419	24R420	24R421	24R111	126359 – 1/2 in x 100 ft (13 mm x 30 m)		
		Hydraulic	100 (30)	100 (30)	50 (15)	600 (41)	101 (45)		24R414	24R415	24R416		126360 – 3/4 in x 75 ft (19 mm x 23 m)		
		12 VDC Electric, 1/2 HP	100 (30)	100 (30)	50 (15)	600 (41)	133 (60)		24R404	24R405	24R406		126361 – 3/4 in x 100 ft (19 mm x 30 m)		
		24 VDC Electric, 1/2 HP	100 (30)	100 (30)	50 (15)	600 (41)	133 (60)		24R407	24R408	24R409		126362 – 1 in x 50 ft (25 mm x 15 m)		
		115 VAC Electric	100 (30)	100 (30)	50 (15)	600 (41)	133 (60)		24R410	24R412	24R413		126375 – 1/2 in x 100 ft (13 mm x 30 m)		
		Pneumatic	100 (30)	100 (30)	50 (15)	3,000 (207)	125 (56)		24R434	24R435	24R436		126376 – 3/4 in x 75 ft (19 mm x 23 m)		
		Hydraulic	100 (30)	100 (30)	50 (15)	3,000 (207)	103 (47)		24R431	24R432	24R433		126377 – 3/4 in x 100 ft (19 mm x 30 m)		
		12 VDC Electric, 1/2 HP	100 (30)	100 (30)	50 (15)	3,000 (207)	134 (61)		24R422	24R423	24R424		126503 – 1 in x 50 ft (25 mm x 15 m)		
	24 VDC Electric, 1/2 HP	100 (30)	100 (30)	50 (15)	3,000 (207)	134 (61)	24R425	24R426	24R427						
	115 VAC Electric	100 (30)	100 (30)	50 (15)	3,000 (207)	134 (61)	24R428	24R429	24R430						
	Diesel Fuel	Pneumatic	100 (30)	100 (30)	50 (15)	600 (41)	123 (56)	1 in/1 in (25 mm/ 25 mm)	24R419	24R420	24R421	24R115	24R102 – 1 in x 50 ft (25 mm x 15 m)		
		Hydraulic	100 (30)	100 (30)	50 (15)	600 (41)	101 (45)		24R414	24R415	24R416				
		12 VDC Electric, 1/2 HP	100 (30)	100 (30)	50 (15)	600 (41)	133 (60)		24R404	24R405	24R406				
		24 VDC Electric, 1/2 HP	100 (30)	100 (30)	50 (15)	600 (41)	133 (60)		24R407	24R408	24R409				
		115 VAC Electric	100 (30)	100 (30)	50 (15)	600 (41)	133 (60)		24R410	24R412	24R413				
		Pneumatic	–	–	50 (15)	600 (41)	123 (56)		24R419	24R420	24R421			24R112	126379 – 1 in x 50 ft (25 mm x 15 m)
		Hydraulic	–	–	50 (15)	600 (41)	101 (45)		24R414	24R415	24R416				
		12 VDC Electric, 1/2 HP	–	–	50 (15)	600 (41)	133 (60)		24R404	24R405	24R406				
	24 VDC Electric, 1/2 HP	–	–	50 (15)	600 (41)	133 (60)	24R407	24R408	24R409						
	115 VAC Electric	–	–	50 (15)	600 (41)	133 (60)	24R410	24R412	24R413						
	Grease	Pneumatic	–	–	50 (15)	3,000 (207)	125 (56)	1 in/1 in (25 mm/ 25 mm)	24R434	24R435	24R436	–	–		
		Hydraulic	–	–	50 (15)	3,000 (207)	103 (47)		24R431	24R432	24R433				
		12 VDC Electric, 1/2 HP	–	–	50 (15)	3,000 (207)	134 (61)		24R422	24R423	24R424				
		24 VDC Electric, 1/2 HP	–	–	50 (15)	3,000 (207)	134 (61)		24R425	24R426	24R427				
115 VAC Electric		–	–	50 (15)	3,000 (207)	134 (61)	24R428		24R429	24R430					



Hose and Cord Reels

### Remember to Order!

 <p><b>Ball Stop Kit</b> See page 259</p>	 <p><b>Hose Guide</b> See page 259</p>	 <p><b>Support Arm</b> See page 259</p>	 <p><b>Hose</b> See page 260-261</p>	 <p><b>Hose Inlet</b> See page 259</p>
--	---	--	--	---

## Ordering Information

### Reel with Motor – 1 in (25 mm) Inlet/Outlet

#### XD 70 / XD 80 Reels

Reel Size	Fluid	Motor	Hose Capacity of Reel ft (m)		Maximum Pressure psi (bar)	Weight lb (kg)	Inlet/Outlet Size NPT(F)	Reel Part Number by Color			Hose Accessories (Must be ordered separately)	
			Hose ID 1 in (25 mm)					Metallic Blue	Yellow	White	Hose Inlet Kit	Hose
XD 7010	Air/Water	Pneumatic	100 (30)	600 (41)	122 (55)	1 in/1 in (25 mm/25 mm)	24R449	24R450	24R451	24R111	126363 – 1 in x 75 ft (25 mm x 23 m) 126364 – 1 in x 100 ft (25 mm x 30 m)	
		Hydraulic	100 (30)	600 (41)	100 (45)		24R446	24R447	24R448			
		12 VDC Electric, 1/2 HP	100 (30)	600 (41)	132 (60)		24R437	24R438	24R439			
		24 VDC Electric, 1/2 HP	100 (30)	600 (41)	132 (60)		24R440	24R441	24R442			
		115 VAC Electric	100 (30)	600 (41)	132 (60)		24R443	24R444	24R445			
	Oil	Pneumatic	100 (30)	3,000 (207)	100 (56)	1 in/1 in (25 mm/25 mm)	24R464	24R465	24R466		126504 – 1 in x 75 ft (25 mm x 23 m) 126505 – 1 in x 100 ft (25 mm x 30 m)	
		Hydraulic	100 (30)	3,000 (207)	102 (46)		24R461	24R462	24R463			
		12 VDC Electric, 1/2 HP	100 (30)	3,000 (207)	133 (60)		24R452	24R453	24R454			
		24 VDC Electric, 1/2 HP	100 (30)	3,000 (207)	133 (60)		24R455	24R456	24R457			
		115 VAC Electric	100 (30)	3,000 (207)	133 (60)		24R458	24R459	24R460			
	Diesel Fuel	Pneumatic	100 (30)	600 (41)	122 (55)	1 in/1 in (25 mm/25 mm)	24R449	24R450	24R451	24R115	24R103 – 1 in x 75 ft (25 mm x 23 m) 24R106 – 1 in x 100 ft (25 mm x 30 m)	
		Hydraulic	100 (30)	600 (41)	100 (45)		24R446	24R447	24R448			
		12 VDC Electric, 1/2 HP	100 (30)	600 (41)	132 (60)		24R437	24R438	24R439			
		24 VDC Electric, 1/2 HP	100 (30)	600 (41)	132 (60)		24R440	24R441	24R442			
		115 VAC Electric	100 (30)	600 (41)	132 (60)		24R443	24R444	24R445			
XD 8010	Air/Water	Pneumatic	150 (46)	600 (41)	164 (74)	1 in/1 in (25 mm/25 mm)	24R531	24R532	24R533	24R111	-	
		Hydraulic	150 (46)	600 (41)	142 (64)		24R528	24R529	24R530			
		12 VDC Electric, 1/2 HP	150 (46)	600 (41)	173 (78)		24R519	24R520	24R521			
		24 VDC Electric, 1/2 HP	150 (46)	600 (41)	173 (78)		24R522	24R523	24R524			
		115 VAC Electric	150 (46)	600 (41)	173 (78)		24R525	24R526	24R527			
	Oil	Pneumatic	150 (46)	3,000 (207)	165 (75)	1 in/1 in (25 mm/25 mm)	24R546	24R547	24R548		-	
		Hydraulic	150 (46)	3,000 (207)	143 (65)		24R543	24R544	24R545			
		12 VDC Electric, 1/2 HP	150 (46)	3,000 (207)	175 (79)		24R534	24R535	24R536			
		24 VDC Electric, 1/2 HP	150 (46)	3,000 (207)	175 (79)		24R537	24R538	24R539			
		115 VAC Electric	150 (46)	3,000 (207)	175 (79)		24R540	24R541	24R542			
	Diesel Fuel	Pneumatic	150 (46)	600 (41)	164 (74)	1 in/1 in (25 mm/25 mm)	24R531	24R532	24R533	24R115	24T252 – 1 in x 150 ft (25 mm x 46 m)	
		Hydraulic	150 (46)	600 (41)	142 (64)		24R528	24R529	24R530			
		12 VDC Electric, 1/2 HP	150 (46)	600 (41)	173 (78)		24R519	24R520	24R521			
		24 VDC Electric, 1/2 HP	150 (46)	600 (41)	173 (78)		24R522	24R523	24R524			
		115 VAC Electric	150 (46)	600 (41)	173 (78)		24R525	24R526	24R527			



Hose and Cord Reels

### Remember to Order!

 <p><b>Ball Stop Kit</b> See page 259</p>	 <p><b>Hose Guide</b> See page 259</p>	 <p><b>Support Arm</b> See page 259</p>	 <p><b>Hose</b> See page 260-261</p>	 <p><b>Hose Inlet</b> See page 259</p>
--	---	--	---	---



# XD Series Bare Hose Reels



60 / 70 / 80

## Ordering Information

### Reel with Motor – 1-1/2 in (38 mm) Inlet/Outlet

#### XD 70 / XD 80 Reels

Reel Size	Fluid	Motor	Hose Capacity of Reel ft (m)	Maximum Pressure psi (bar)	Weight lb (kg)	Inlet/Outlet Size NPT(F)	Reel Part Number by Color			Hose Accessories (Must be ordered separately)	
			Hose ID 1-1/2 in (38 mm)				Metallic Blue	Yellow	White	Hose Inlet Kit	Hose
XD 7015	Diesel Fuel	Pneumatic	65 (20)	600 (41)	100 (56)	1-1/2 in / 1-1/2 in (38 mm / 38 mm)	24R516	24R517	24R518	24R117	24R110 – 1-1/4 in x 50 ft (32 mm x 15 m) 24R114 – 1-1/2 in x 50 ft (38 mm x 15 m)
		Hydraulic	65 (20)	600 (41)	102 (46)		24R512	24R513	24R515		
		12 VDC Electric, 1/2 HP	65 (20)	600 (41)	133 (60)		24R503	24R504	24R505		
		24 VDC Electric, 1/2 HP	65 (20)	600 (41)	133 (60)		24R506	24R507	24R508		
		115 VAC Electric	65 (20)	600 (41)	133 (60)		24R509	24R510	24R511		
	Waste Oil Evac.	Pneumatic	50 (15)	600 (41)	100 (56)		24R516	24R517	24R518	-	126380 – 1-1/4 in x 35 ft (32 mm x 11 m) 126688 – 1-1/4 in x 50 ft (32 mm x 15 m) 127173 – 1-1/2 in x 50 ft (38 mm x 15 m)
		Hydraulic	50 (15)	600 (41)	102 (46)		24R512	24R513	24R515		
		12 VDC Electric, 1/2 HP	50 (15)	600 (41)	133 (60)		24R503	24R504	24R505		
		24 VDC Electric, 1/2 HP	50 (15)	600 (41)	133 (60)		24R506	24R507	24R508		
		115 VAC Electric	50 (15)	600 (41)	133 (60)		24R509	24R510	24R511		
XD 8015	Diesel Fuel	Pneumatic	100 (50)	600 (41)	165 (75)	24R561	24R562	24R563	24R117	24T253 – 1-1/2 in x 100 ft (38 mm x 30 m)	
		Hydraulic	100 (50)	600 (41)	143 (65)	24R558	24R559	24R560			
		12 VDC Electric, 1/2 HP	100 (50)	600 (41)	175 (79)	24R549	24R550	24R551			
		24 VDC Electric, 1/2 HP	100 (50)	600 (41)	175 (79)	24R552	24R553	24R554			
		115 VAC Electric	100 (50)	600 (41)	175 (79)	24R555	24R556	24R557			

### Reel with Motor – 2 in (51 mm) Inlet/Outlet

#### XD 70 / XD 80 Reels

Reel Size	Fluid	Motor	Hose Capacity of Reel ft (m)	Maximum Pressure psi (bar)	Weight lb (kg)	Inlet/Outlet Size NPT(F)	Reel Part Number by Color			Hose Accessories (Must be ordered separately)	
			Hose ID 2 in (51 mm)				Metallic Blue	Yellow	White	Hose Inlet Kit	Hose
XD 7020	Diesel Fuel	Pneumatic	33 (10)	600 (41)	128 (58)	2 in/2 in (51 mm / 51 mm)	24T023	24T024	24T025	24R118	127167 – 2 in x 33 ft (51 mm x 10 m)
		Hydraulic	33 (10)	600 (41)	106 (48)		24T020	24T021	24T022		
		12 VDC Electric, 1/2 HP	33 (10)	600 (41)	137 (62)		24T011	24T012	24T013		
		24 VDC Electric, 1/2 HP	33 (10)	600 (41)	137 (62)		24T014	24T015	24T016		
		115 VAC Electric	33 (10)	600 (41)	137 (62)		24T017	24T018	24T019		
		XD 8020	Diesel Fuel	Pneumatic	50 (15)		600 (41)	169 (76)	24R576		
Hydraulic	50 (15)			600 (41)	147 (67)		24R573	24R574	24R575		
12 VDC Electric, 1/2 HP	50 (15)			600 (41)	179 (81)		24R564	24R565	24R566		
24 VDC Electric, 1/2 HP	50 (15)			600 (41)	179 (81)		24R567	24R568	24R569		
115 VAC Electric	50 (15)			600 (41)	179 (81)		24R570	24R571	24R572		

### Remember to Order!

 <b>Ball Stop Kit</b> See page 259	 <b>Hose Guide</b> See page 259	 <b>Support Arm</b> See page 259	 <b>Hose</b> See page 260-261	 <b>Hose Inlet</b> See page 259
---	--	---	---	--

## Ordering Information

### Reel Frames Only

#### XD 60 / XD 70 / XD 80 Reels

Motor is not included and must be purchased separately.

Reel Size	Fluid	Hose Capacity of Reel ft (m)					Maximum Pressure psi (bar)	Weight lb (kg)	Inlet/Outlet Size NPT(F)	Reel Part Number by Color				
		Hose ID in (mm)								Metallic Blue	Yellow	White		
		1/2 (13)	3/4 (19)	1 (25)	1-1/2 (38)	2 (51)								
XD 6010	Air/Water/Diesel Fuel	100 (30)	100 (30)	50 (15)	-	-	600 (41)	87 (39)	1 in/1 in (25 mm/25 mm)	24T104	24T105	24T106		
	Oil	100 (30)	100 (30)	50 (15)	-	-	3,000 (207)	88 (40)		24T107	24T108	24T109		
	Waste Oil Evac.	-	-	50 (15)	-	-	600 (41)	87 (39)		24T104	24T105	24T106		
	Grease	-	-	50 (15)	-	-	3,000 (207)	88 (40)		24T107	24T108	24T109		
XD 7010	Air/Water/Diesel Fuel	-	-	100 (30)	-	-	600 (41)	86 (39)		24T110	24T111	24T112		
	Oil	-	-	100 (30)	-	-	3,000 (207)	87 (39)		24T113	24T114	24T115		
XD 8010	Air/Water/Diesel Fuel	-	-	150 (46)	-	-	600 (41)	127 (58)		24T122	24T123	24T124		
	Oil	-	-	150 (46)	-	-	3,000 (207)	129 (58)		24T125	24T126	24T127		
XD 7015	Diesel Fuel	Waste Oil Evac.	-	-	-	50 (15)	-	600 (41)		87 (39)	1-1/2 in/1-1/2 in (38 mm/38 mm)	24T116	24T117	24T118
			-	-	-	65 (20)	-	600 (41)		87 (39)		24T116	24T117	24T118
XD 8015	-	-	-	-	100 (30)	-	600 (41)	129 (58)		24T128		24T129	24T130	
XD 7020	-	-	-	-	-	33 (10)	600 (41)	91 (41)		24T119		24T120	24T121	
XD 8020	-	-	-	-	-	-	600 (41)	133 (60)	2 in/2 in (51 mm/51 mm)	24T131		24T132	24T133	
		-	-	-	-	50 (15)	600 (41)	133 (60)		24T131		24T132	24T133	

### Motor Assemblies – Pair with Frame-Only Models

Image	Part Number	Description
	24T892	Pneumatic motor assembly, reversible type. For installing motor to bare XD reel.
	24T891	Hydraulic motor assembly, reversible type. For installing motor to bare XD reel.
	24T886	12 VDC, 1/2 HP motor assembly, reversible type. For installing motor to bare XD frame.
	24T910	12 VDC, 2/3 HP motor assembly, reversible type. For installing motor to bare XD frame.
	24T888	24 VDC, 1/2 HP motor assembly, reversible type. For installing motor to bare XD frame.
	24T911	24 VDC, 2/3 HP motor assembly, reversible type. For installing motor to bare XD frame.
	24T889	115 VAC, 0.40 HP motor assembly, reversible type. For installing motor to bare XD frame.









### Remember to Order!

<b>Ball Stop Kit</b> See page 259	<b>Hose Guide</b> See page 259	<b>Support Arm</b> See page 259	<b>Hose</b> See page 260-261	<b>Hose Inlet</b> See page 259



## Ordering Information

### Motor Controls (Required)

	Part Number	Description
	127271	Pneumatic valve to control XD 60/70/80 pneumatic powered hose reels. 2-position, 3-way valve.
	24T875	Hydraulic control module for electric over hydraulic control of XD 60/70/80 hydraulic powered hose reels, 12 VDC. 3-position, 4-way valve.
	24T876	Hydraulic control module for electric over hydraulic control of XD 60/70/80 hydraulic powered hose reels, 24 VDC. 3-position, 4-way valve.
	127224	Hydraulic control module for electric over hydraulic control of XD 60/70/80 hydraulic powered hose reels, 12V, includes switch. 3-position, 4-way valve.
	127225	Hydraulic control module for electric over hydraulic control of XD 60/70/80 hydraulic powered hose reels, 24V, includes switch. 3-position, 4-way valve.
	127214	Momentary push-button on/off switch with red rubber cap. Use for 12 or 24 VDC.
	127217	Hazardous-location push-button on/off switch. Use for 12 and 24 VDC.
	127223	Hazardous-location push-button on/off switch. Use for 115 and 220 VAC.
	127218	Hazardous-location junction box
	127219	12 VDC intermittent-duty solenoid recommended for activating rewind on 12 VDC motor
	127220	24 VDC intermittent-duty solenoid recommended for activating rewind on 24 VDC motor
	127221	Manual-reset push-button circuit breaker, 50 amp rating
	127222	Manual-reset push-button circuit breaker, 25 amp rating

## Ordering Information

### Ball Stop Kits

	Part Number	Description
	237873	Ball stop kit used for 3/4 in (19 mm) hose
	237874	Ball stop kit used for 1 in (25 mm) hose
	24R060	Ball stop kit used for 1.25 in (32 mm) hose
	24R061	Ball stop kit used for 1.5 in (38 mm) hose

### Hose Guide

	Part Number	Description
	24T327	Stainless steel hose guide for XD 60
	24T328	Stainless steel hose guide for XD 70
	24T329	Stainless steel hose guide for XD 80
	24R072	Roller guide kit with bracket for XD 40 and XD 60
	24T330	Roller guide kit with bracket for XD 70
	24T331	Roller guide kit with bracket for XD 80

### Support Arm Kit with Hose Guide

	Part Number	Description
	24T332	Arm kit with stainless steel hose guide for XD 60 (24T327)
	24T333	Arm kit with stainless steel hose guide for XD 70 (24T328)
	24T334	Arm kit with stainless steel hose guide for XD 80 (24T329)
	24T335	Arm kit with roller guide for XD 60 (24R072)
	24T336	Arm kit with roller guide for XD 70 (24T330)
	24T337	Arm kit with roller guide for XD 80 (24T331)

### Hose Inlet Kits

	Part Number	Description
	24R111	1 in (25 mm) hose inlet kit for air/water and oil 1,275 psi (88 bar), 1 in NPT hose inlet ID, 28 in (710 mm) long
	24R112	1 in (25 mm) hose inlet kit for waste oil evacuation 250 psi (17 bar), 1 in NPT hose inlet ID, 28 in (710 mm) long
	24R115	1 in (25 mm) hose inlet kit for diesel fuel 250 psi (17 bar), 1 in NPT hose inlet ID, 28 in (710 mm) long
	24R117	1-1/2 in (38 mm) hose inlet kit for diesel fuel 150 psi (10 bar), 1-1/2 in NPT hose inlet ID, 28 in (710 mm) long
	24R118	2 in (51 mm) hose inlet kit for diesel fuel 150 psi (10 bar), 2 in NPT hose inlet ID, 28 in (710 mm) long
	24T858	1-1/2 in (38 mm) hose inlet kit for waste oil evacuation 150 psi (10 bar), 1-1/2 in NPT hose inlet ID, 28 in (710 mm) long

### Self-Adhesive Identification Label Set

	Part Number	Description
	180698	Set includes: 1 in x 5 in (25.4 mm x 127 mm) hose reels labels for Antifreeze, Water, SAE 5-40, SAE 10-40, SAE 20W, Hydraulic, Gear, SAE 10W, SAE 10-30, SAE 30W, Dexron, Air, Chassis, ATF

Hose and Cord Reels



## Ordering Information

### Hose Identification Wraps

Vinyl hose wrap for easy identification of meter fluid

	Part Number	Description
	17S659	Red
	17S660	Blue
	17S661	Green
	17S662	Yellow
	17S663	White

### Air/Water/Antifreeze Hoses

	Part Number	Description	Compatible Reel Series
	253848	3/8 in x 35 ft (10 mm x 11 m) hose for air/water, 300 psi (20.6 bar)	SDX 10, XDX 10
	253849	3/8 in x 50 ft (10 mm x 15 m) hose for air/water, 300 psi (20.6 bar)	SDX 10, XDX 10
	253850	3/8 in x 65 ft (10 mm x 20 m) hose for air/water, 300 psi (20.6 bar)	SDX 20, XDX 20
	253852	1/2 in x 35 ft (13 mm x 11 m) hose for air/water, 300 psi (20.6 bar)	SDX 10, XDX 10
	253853	1/2 in x 50 ft (13 mm x 15 m) hose for air/water, 300 psi (20.6 bar)	SDX 20, XDX 20
	16A684	1/2 in x 75 ft (13 mm x 23 m) hose for air/water, 300 psi (20.6 bar)	XD 30
	126359	1/2 in x 100 ft (13 mm x 30 m) hose for air/water, 300 psi (20.6 bar)	XD 40, XD 60
	16A707	3/4 in x 50 ft (19 mm x 15 m) hose for air/water, 300 psi (20.6 bar)	XD 30
	126360	3/4 in x 75 ft (19 mm x 23 m) hose for air/water, 300 psi (20.6 bar)	XD 40
	126361	3/4 in x 100 ft (19 mm x 30 m) hose for air/water, 300 psi (20.6 bar)	XD 40, XD 60
	126362	1 in x 50 ft (25 mm x 15 m) hose for air/water, 300 psi (20.6 bar)	XD 40, XD 60
	126363	1 in x 75 ft (25 mm x 23 m) hose for air/water, 300 psi (20.6 bar)	XD 50
	126364	1 in x 100 ft (25 mm x 30 m) hose for air/water, 300 psi (20.6 bar)	XD 50, XD 70

### Oil Hoses

	Part Number	Description	Compatible Reel Series
	26C121	1/2 in x 35 ft (13 mm x 11 m) hose for oil, 2,000 psi (138 bar)	SDX 10, XDX 10
	26C122	1/2 in x 50 ft (13 mm x 15 m) hose for oil, 2,000 psi (138 bar)	SDX 20, XDX 20
	26C123	1/2 in x 75 ft (13 mm x 23 m) hose for oil, 2,000 psi (138 bar)	XD 30
	26C124	1/2 in x 100 ft (13 mm x 30 m) hose for oil, 2,000 psi (138 bar)	XD 40, XD 60
	126376	3/4 in x 75 ft (19 mm x 23 m) hose for oil, 1,500 psi (103 bar)	XD 40, XD 60
	126377	3/4 in x 100 ft (19 mm x 30 m) hose for oil, 1,500 psi (103 bar)	XD 40, XD 60
	126503	1 in x 50 ft (25 mm x 15 m) hose for oil, 1,275 psi (88 bar)	XD 40, XD 60
	126504	1 in x 75 ft (25 mm x 23 m) hose for oil, 1,275 psi (88 bar)	XD 50
	126505	1 in x 100 ft (25 mm x 30 m) hose for oil, 1,275 psi (88 bar)	XD 70, XD 80

## Ordering Information

### Grease Hoses

	Part Number	Description	Compatible Reel Series
	109158	1/4 in x 50 ft (6 mm x 15m) hose for grease, 5,000 psi (345 bar)	SDX 10, XDX 10
	124470	3/8 in x 35 ft (10 mm x 11 m) hose for grease, 4,800 psi (331 bar)	SDX 10, XDX 10
	124461	3/8 in x 50 ft (10 mm x 15 m) hose for grease, 4,800 psi (331 bar)	SDX 20, XDX 20
	126076	3/8 in x 75 ft (10 mm x 23m) hose for grease, 5,000 psi (345 bar)	XD 30
	16A674	1/2 in x 50 ft (13 mm x 15 m) hose for grease, 5,000 psi (345 bar)	XD 30

### Waste Oil Evacuation Hoses

	Part Number	Description	Compatible Reel Series
	16A686	1 in x 30 ft (25 mm x 9 m) hose for waste oil or fuel, 125 psi (9 bar)	XD 30
	126379	1 in x 50 ft (25 mm x 15 m) hose for waste oil, 250 psi (17 bar)	XD 40, XD 60
	126380	1 1/4 in x 35 ft (32 mm x 10.5 m) hose for waste oil, 200 psi (13.8 bar)	XD 50
	126688	1 1/4 in x 50 ft (32 mm x 15 m) hose for waste oil, 200 psi (13.8 bar)	XD 50
	127173	1 1/2 in x 50 ft (38 mm x 15 m) hose for waste oil, 200 psi (13.8 bar)	XD 50

### Diesel Fuel Hoses

	Part Number	Description	Compatible Reel Series
	16A686	1 in x 30 ft (25 mm x 9 m) hose for waste oil or fuel, 125 psi (9 bar)	XD 30
	24R102	1 in x 50 ft (25 mm x 15 m) hose for diesel fuel, 250 psi (17 bar)	XD 40, XD 60
	24R103	1 in x 75 ft (25 mm x 23 m) hose for diesel fuel, 250 psi (17 bar)	XD 50
	24R106	1 in x 100 ft (25 mm x 30 m) hose for diesel fuel, 250 psi (17 bar)	XD 50, XD 70
	24T252	1 in x 150 ft (25 mm x 46 m) hose for diesel fuel, 250 psi (17 bar)	XD 80
	24R108	1 1/4 in x 35 ft (32 mm x 10.5 m) hose for diesel fuel, 250 psi (17 bar)	XD 50
	24R110	1 1/4 in x 50 ft (32 mm x 15 m) hose for diesel fuel, 250 psi (17 bar)	XD 50
	24R114	1 1/2 in x 50 ft (38 mm x 15 m) hose for diesel fuel, 150 psi (11 bar)	XD 50
	24T253	1 1/2 in x 100 ft (38 mm x 30 m) hose for diesel fuel, 150 psi (11 bar)	XD 80
	127167	2 in x 33 ft (51 mm x 10 m) hose for diesel fuel, 150 psi (11 bar)	XD 80
	24T254	2 in x 50 ft (51 mm x 15 m) hose for diesel fuel, 150 psi (11 bar)	XD 80

### Diesel Exhaust Fluid (DEF) Hoses

	Part Number	Description	Compatible Reel Series
	125242	3/4 in x 50 ft (19 mm x 15 m) hose for DEF fluid, 50 psi (3 bar)	XD 30

### Pressure Wash Hoses

	Part Number	Description	Compatible Reel Series
	16A688	3/8 in x 75 ft (10 mm x 23m) hose for pressure wash, 4,000 psi (276 bar)	XD 30
	126075	1/2 in x 50 ft (13 mm x 15 m) hose for pressure wash, 4,500 psi (310 bar)	XD 30

Hose and Cord Reels