

# Xtreme<sup>®</sup> Lowers

311762ZAR

EN

**High volume lowers for protective coatings. For professional use only.**

See page 3 for model information. See page 35 for maximum working pressure.



### Important Safety Instructions

Read all warnings and instructions in this manual and related manuals before using the equipment. Save these instructions.

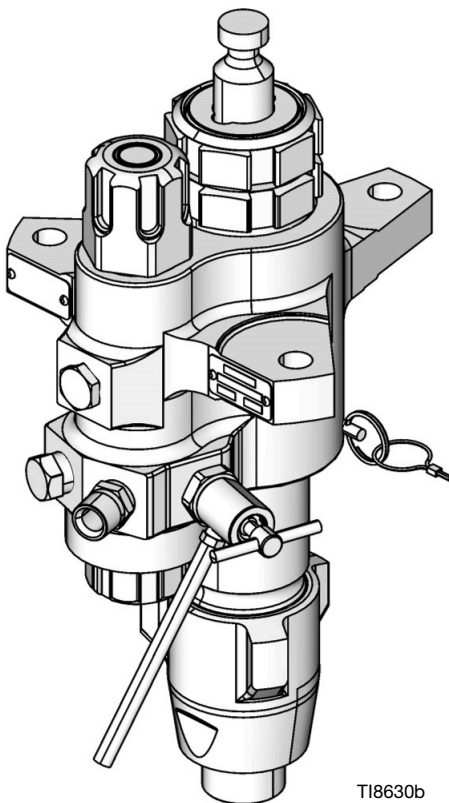

T18630b

Model L220C2 Lower with Built-in Filter

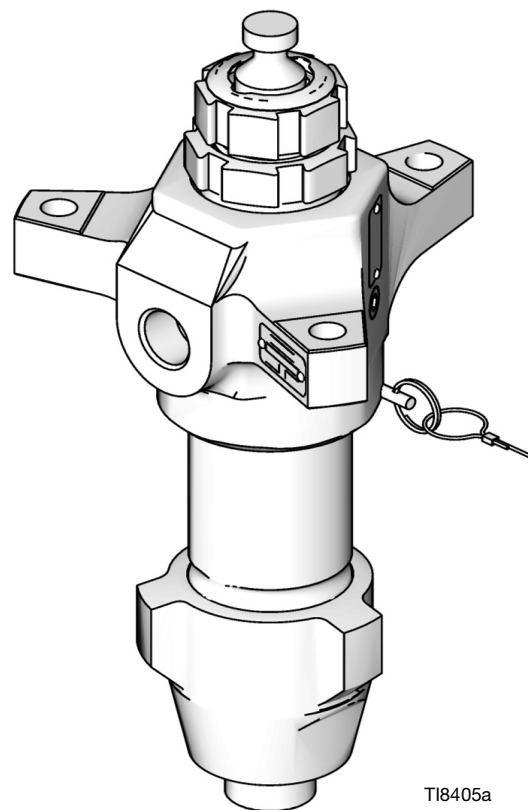

T18405a

Model L220C1 Lower without Filter

# Contents

**Related Manuals** ..... 2  
**Models** ..... 3  
**Warnings** ..... 4  
**Component Identification**..... 6  
**Repair** ..... 7  
    Disassembly ..... 7  
    Service Built-in Filter ..... 14  
**Parts**..... 16  
    XP Sprayer Lower Models  
        36cc, 48cc, 54cc, 58cc, 72cc, 85cc, 90cc,  
        97cc, and 115cc..... 16  
    XP Sprayer Lower Models  
        145cc, 180cc, 220cc, 250cc, and 290cc ..... 19  
    Xtreme, e-Xtreme, and King Sprayer Lower Models  
        85cc 115cc, 145cc, 180cc, 220cc, 250cc,  
        and 290cc..... 21  
**Repair Kits** ..... 27  
    Repair Kits - Graco Formulated UHMWPE/Leather . . . 27  
    Repair Kits - PTFE ..... 28  
    Repair Kits - Graco Formulated UHMWPE/PTFE . . . 29  
    Repair Kits - Graco Formulated PTFE/Leather . . . . . 30  
**Kits** ..... 31  
    Ceramic Balls..... 31  
**Dimensions** ..... 33  
**Outlet Housing Mounting Hole Layout** ..... 34  
**Technical Specifications**..... 35  
**California Proposition 65** ..... 37  
**Graco Standard Warranty**..... 38  
**Graco Information**..... 38

# Related Manuals

Manual in English	Description
3A3164	e-Xtreme™ Sprayer, Ex35/Ex45
3A8126	King® Electric Sprayer, E60/E50, Haz Loc
3A8477	King Electric Sprayer, E70/E60, Non-Haz Loc
311164	Xtreme Packages Instructions and Parts
3A0420	XP™ Sprayer Operation
311238	NXT® Air Motor Instructions and Parts
311239	Air Control Modules for NXT Air Motors Instructions and Parts
334645	Xtreme XL Packages, Instructions and Parts
<b>Xtreme Lower Repair Kits</b>	
406882	Filter Seal and Cap Conversion Kit, Instructions-Parts
406879	XP 36cc Lower, Repair-Parts
406880	XP 48cc Lower, Repair-Parts
406990	XP 54cc Lower, Repair-Parts
406881	XP 58cc Lower, Repair-Parts
406991	XP 72cc Lower, Repair-Parts
406888	XP/Xtreme 85cc Lower, Repair-Parts
406992	XP 90cc Lower, Repair-Parts
406993	XP 97cc Lower, Repair-Parts
406889	XP/Xtreme 115cc Lower, Repair-Parts
406890	XP/Xtreme 145cc Lower, Repair-Parts
406891	XP/Xtreme 180c Lower, Repair-Parts
406892	XP/Xtreme 220cc Lower, Repair-Parts
406893	XP/Xtreme 250cc Lower, Repair-Parts
406894	XP/Xtreme 290cc Lower, Repair-Parts

# Models

Check the identification plate (ID) on your lower for the 6-digit part number of your lower. Use the following matrix to define the

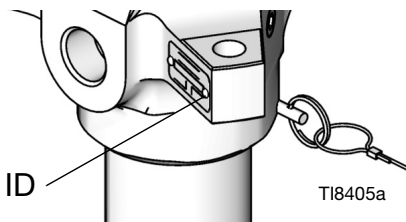

construction of your lower, based on the six digits. For example, Lower Part Number **L180C1** represents the lower (L), output volume (180), carbon steel construction (C), and no filter with Xtreme Seal™ packing stack (1).

To order replacement parts, see **Parts**, starting on page 16.

**NOTE:** For maximum fluid working pressures, see **Technical Specifications**, page 35.

L	180	C		1							
		Fifth Digit		Sixth Digit							
First Digit	Lower Volume (cc)		Material		Integrated Filter	UHMWPE and Leather Packing Set*	PTFE Packing Set*	UHMWPE/PTFE Packing Set*	PTFE/Leather Packing Set		
L (lower)	36★	C	Carbon Steel	0☼	✓				✓		
	48★			1		✓					
	54★			2	✓	✓					
	58★			3			✓				
	72★			4	✓		✓				
	85★			5†	✓	✓					
	90★			6†		✓					
	97★			7					✓	✓	
	115★			8†		✓					
	145			9†			✓				
	14A★			L†	✓	✓					
	180			N†		✓					
	18A★			T†						✓	
	220										
	22A★										
	22H										
	22X★										
	250										
	25H										
	25A★										
290											
29A★											
29H											
145	M	Max Life	2	✓	✓						
180				✓	✓						
220				✓	✓						
290				✓	✓						

- ★ Models with a 5.9 in. bolt pattern; see page 34.
- ☼ XP proportioner models with inlet spring and no purge valve.
- \* See **Repair Kits**, page 27, for packing material details.
- † Includes rupture disc.

**Note:** Not all options are available in all sizes.

Part	Description	Packings
24N942	290 Xtreme carbon steel, with hard chrome rod	X-Tuff Packing Set
25A710†	250 Xtreme for high temperature application	Tuff Stack Packing Set

# Warnings

The following warnings are for the setup, use, grounding, maintenance, and repair of this equipment. The exclamation point symbol alerts you to a general warning and the hazard symbol refers to procedure-specific risk. Refer back to these warnings. Additional, product-specific warnings may be found throughout the body of this manual where applicable.

 <h2 style="margin: 0;">WARNING</h2>	
   	<p><b>FIRE AND EXPLOSION HAZARD</b></p> <p>Flammable fumes, such as solvent and paint fumes, in work area can ignite or explode. Paint or solvent flowing through the equipment can cause static sparking. To help prevent fire and explosion:</p> <ul style="list-style-type: none"> <li>• Use equipment only in well-ventilated area.</li> <li>• Eliminate all ignition sources, such as pilot lights, cigarettes, portable electric lamps, and plastic drop cloths (potential static sparking).</li> <li>• Ground all equipment in the work area. See <b>Grounding</b> instructions.</li> <li>• Never spray or flush solvent at high pressure.</li> <li>• Keep work area free of debris, including solvent, rags and gasoline.</li> <li>• Do not plug or unplug power cords, or turn power or light switches on or off when flammable fumes are present.</li> <li>• Use only grounded hoses.</li> <li>• Hold gun firmly to side of grounded pail when triggering into pail. Do not use pail liners unless they are anti-static or conductive.</li> <li>• <b>Stop operation immediately</b> if static sparking occurs or you feel a shock. Do not use equipment until you identify and correct the problem.</li> <li>• Keep a working fire extinguisher in the work area.</li> </ul>
    	<p><b>SKIN INJECTION HAZARD</b></p> <p>High-pressure fluid from gun, hose leaks, or ruptured components will pierce skin. This may look like just a cut, but it is a serious injury that can result in amputation. <b>Get immediate surgical treatment.</b></p> <ul style="list-style-type: none"> <li>• Do not spray without tip guard and trigger guard installed.</li> <li>• Engage trigger lock when not spraying.</li> <li>• Do not point gun at anyone or at any part of the body.</li> <li>• Do not put your hand over the spray tip.</li> <li>• Do not stop or deflect leaks with your hand, body, glove, or rag.</li> <li>• Follow the <b>Pressure Relief Procedure</b> when you stop spraying and before cleaning, checking, or servicing equipment.</li> <li>• Tighten all fluid connections before operating the equipment.</li> <li>• Check hoses and couplings daily. Replace worn or damaged parts immediately.</li> </ul>

# ! WARNING



## EQUIPMENT MISUSE HAZARD

Misuse can cause death or serious injury.



- Do not operate the unit when fatigued or under the influence of drugs or alcohol.
- Do not exceed the maximum working pressure or temperature rating of the lowest rated system component. See **Technical Specifications** in all equipment manuals.
- Use fluids and solvents that are compatible with equipment wetted parts. See **Technical Specifications** in all equipment manuals. Read fluid and solvent manufacturer's warnings. For complete information about your material, request Safety Data Sheets (SDSs) from distributor or retailer.
- Turn off all equipment and follow the **Pressure Relief Procedure** when equipment is not in use.
- Check equipment daily. Repair or replace worn or damaged parts immediately with genuine manufacturer's replacement parts only.
- Do not alter or modify equipment. Alterations or modifications may void agency approvals and create safety hazards.
- Make sure all equipment is rated and approved for the environment in which you are using it.
- Use equipment only for its intended purpose. Call your distributor for information.
- Route hoses and cables away from traffic areas, sharp edges, moving parts, and hot surfaces.
- Do not kink or over bend hoses or use hoses to pull equipment.
- Keep children and animals away from work area.
- Comply with all applicable safety regulations.



## MOVING PARTS HAZARD

Moving parts can pinch, cut or amputate fingers and other body parts.



- Keep clear of moving parts.
- Do not operate equipment with protective guards or covers removed.
- Equipment can start without warning. Before checking, moving, or servicing equipment, follow the **Pressure Relief Procedure** and disconnect all power sources.



## TOXIC FLUID OR FUMES HAZARD

Toxic fluids or fumes can cause serious injury or death if splashed in the eyes or on skin, inhaled, or swallowed.

- Read Safety Data Sheets (SDSs) to know the specific hazards of the fluids you are using.
- Store hazardous fluid in approved containers, and dispose of it according to applicable guidelines.



## PERSONAL PROTECTIVE EQUIPMENT

Wear appropriate protective equipment when in the work area to help prevent serious injury, including eye injury, hearing loss, inhalation of toxic fumes, and burns. Protective equipment includes but is not limited to:

- Protective eyewear, and hearing protection.
- Respirators, protective clothing, and gloves as recommended by the fluid and solvent manufacturer.

# Component Identification

(Shown with Built-in Filter)

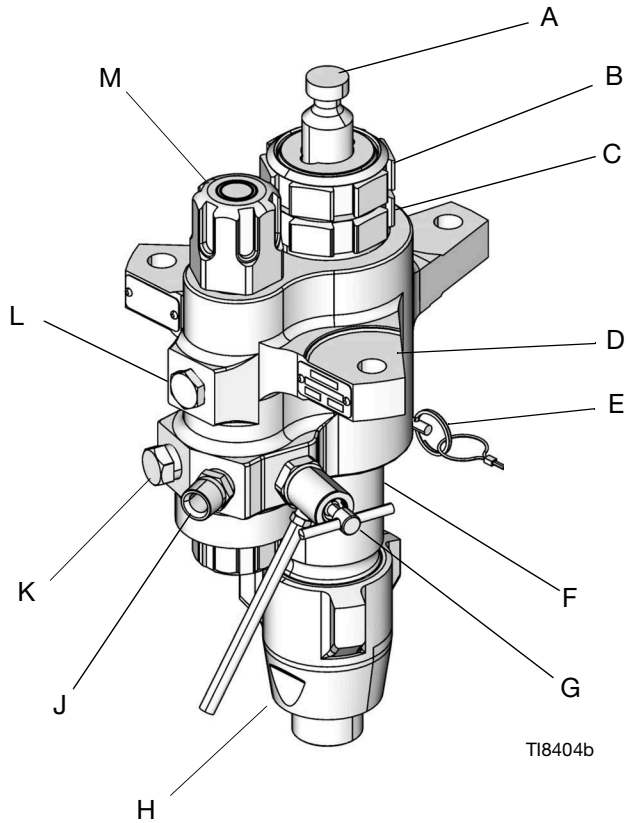

## XP Sprayer Xtreme Lowers and e-Xtreme Sprayer Lowers

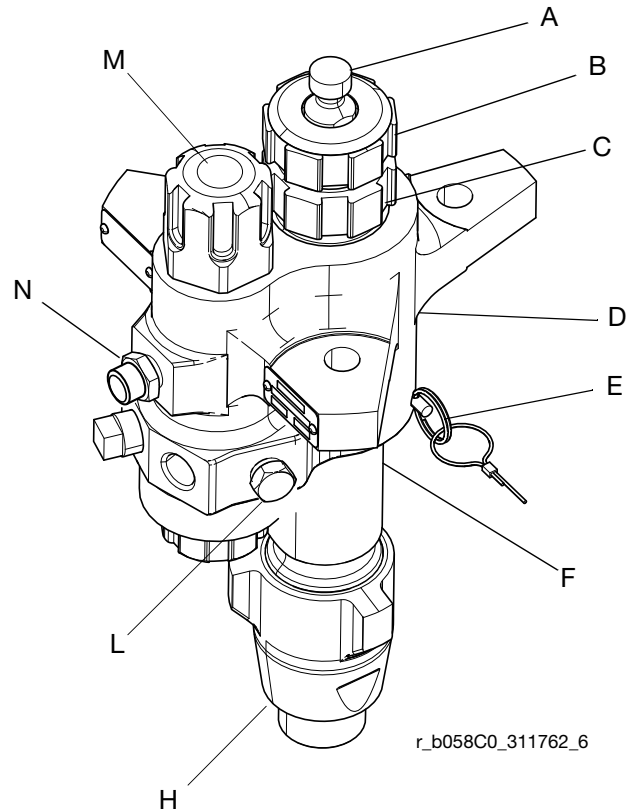

◆ e-Xtreme Sprayer Lowers use opposite locations for the pipe plug and rupture disc. The pipe plug is installed at location (N), and the rupture disc is installed at location (L).

**Key:**

- A Displacement Rod
- B Packing Nut
- C Throat Cartridge
- D Outlet Housing
- E Locking Pin
- F Cylinder
- G Drain/Purge Valve (not on XP Lowers)

- H Inlet Housing
- J Fluid Outlet
- K Optional Fluid Outlet (for second spray gun; not on XP Lowers)
- L Pipe Plug (non-filtered outlet)
- M Fluid Filter
- N Over Pressure Rupture Disc (for 36cc–145cc only)

# Repair

## Required Tools

- Set of adjustable wrenches
- Torque wrench
- Rubber mallet
- Arbor press
- Soft wooden block (approx. 1 square ft in size)
- Large vise with soft jaws
- Thread lubricant
- Petroleum jelly
- Anti-seize lubricant

## Disassembly

Lay out all removed parts in sequence to ease reassembly. Clean all parts with a compatible solvent and inspect them for wear or damage.

**NOTE:** Repair kits are available to replace the throat (3) and piston (4) packings, and to replace the o-rings and cylinder seals. For best results, use all new parts in the kit. Kit parts are marked with an asterisk, for example (25\*). These kits can also be used to convert the lower to different packing materials. See the Packing Kits sections.



1. Follow the Pressure Relief Procedure detailed in your sprayer manual, **Related Manuals**, page 2.
2. Disconnect lower from motor as illustrated in your system manual, **Related Manuals**, page 2. If you have a cart mounted system, tip cart up to service lower on cart.
3. For lowers with built-in filters, loosen and remove both top filter cap (20) and bottom filter cap (26). See **Service Built-in Filter**, page 14.

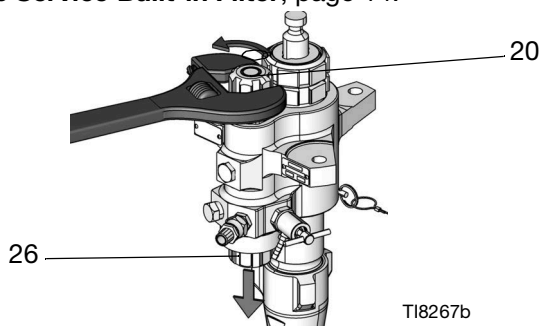

4. Loosen and remove inlet housing (14) from lower cylinder (11).

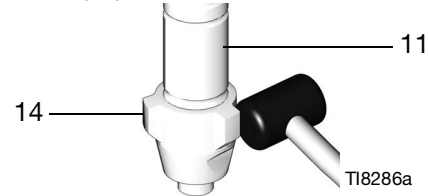

5. Press inlet ball (16) out from bottom of inlet housing (14) (take care not to damage seat (18) to remove entire inlet ball guide assembly).

**NOTE:** On model L180C7 only, shims (17) will be below inlet ball guide (15).

- a. **For Xtreme Lowers:** Remove inlet ball, bottom o-ring (27\*), and seat. Then remove remaining o-rings from top and bottom grooves of inlet ball guide (15).

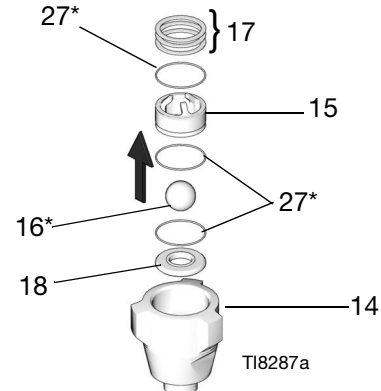

**FIG. 1: Disassemble Xtreme Lowers**

- b. **For XP Lowers 115 and smaller:** Remove spring, inlet ball, bottom o-ring, and shims. Then remove remaining o-rings from top and bottom grooves of inlet ball guide (15).

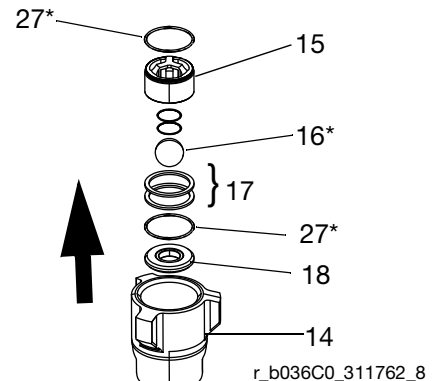

**FIG. 2: Disassemble XP Lowers 115 and smaller**

- c. **For XP Lowers 145cc and larger:** Remove inlet ball, bottom o-ring, and shim. Then remove remaining o-rings from top and bottom grooves of inlet ball guide (15).

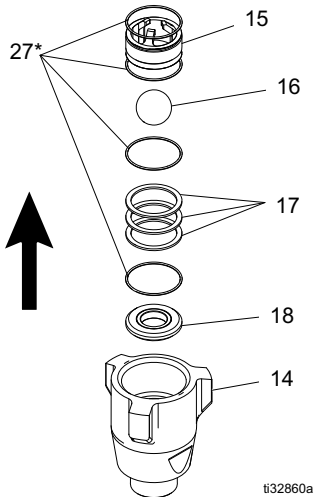

T132860a

**FIG. 3: Disassemble XP Lowers 145cc and larger**

6. Stand lower upright in large vise. Using a rubber mallet, loosen, but do not remove packing nut (2).

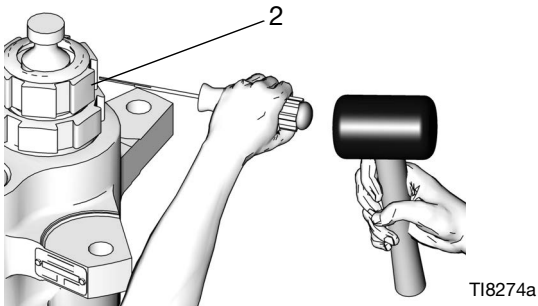

T18274a

7. Remove locking pin (10) from lower cylinder (11).

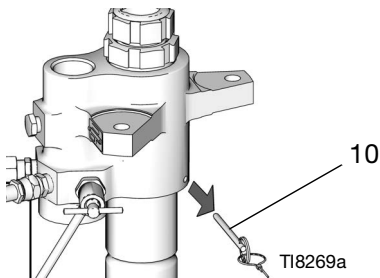

T18269a

8. Unscrew and lift outlet housing (8) straight up off cylinder. Be careful not to scratch displacement rod (1).

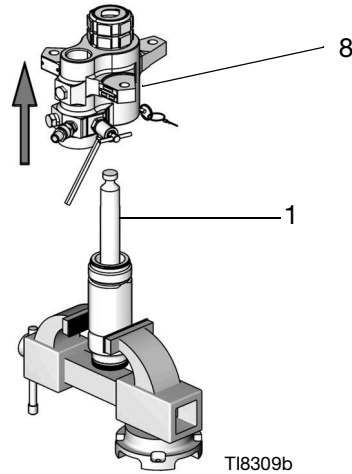

T18309b

9. Remove cartridge assembly. Remove o-ring (27\* or 29\*) from bottom of outlet housing (8), and then unscrew packing nut (2) from packing cartridge (7). Remove female gland, male gland, v-packings (3), and spring from packing cartridge (7).

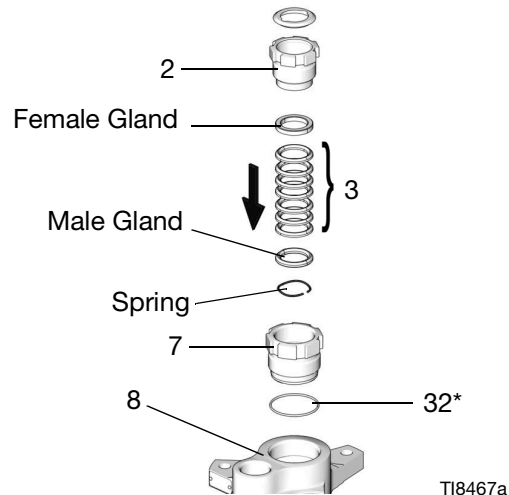

T18467a

**NOTICE**

To reduce the possibility of costly damage to displacement rod (1) and lower cylinder (11), first place lower cylinder on a soft block of wood. Always use a rubber mallet or an arbor press to drive the displacement rod out of the lower cylinder. Never use a hammer to drive the rod out. Damage to the rod end will shorten pump life.



10. Stand lower cylinder (11) upright on a wooden block. Using a rubber mallet or an arbor press, drive displacement rod (1) out of the bottom until the piston comes free. Pull the rod and piston from the cylinder, being careful not to scratch the rod or cylinder.

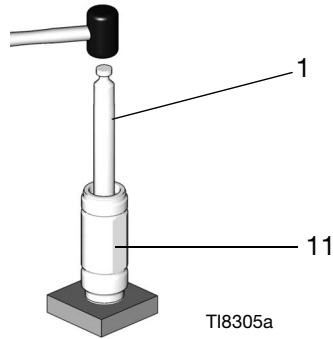

11. Inspect outer surface of displacement rod (1) and inner surface of lower cylinder (11) for scoring or wear; replace if damaged.

12. Put flats of piston valve (13) in a vise. Use a wrench to loosen displacement rod (1) from piston valve.

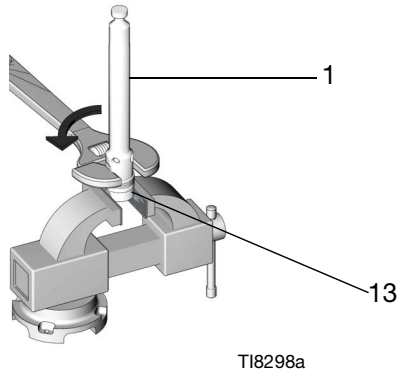

13. Remove displacement rod from piston valve. Be careful that piston ball (12\*) does not fall as you separate piston valve and rod.

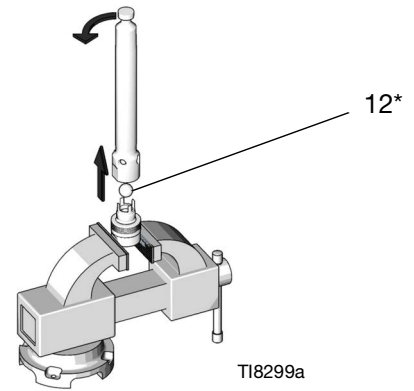

14. Remove glands and v-packings (4) from piston valve (13). Inspect piston ball (12\*) and piston valve for wear or damage.

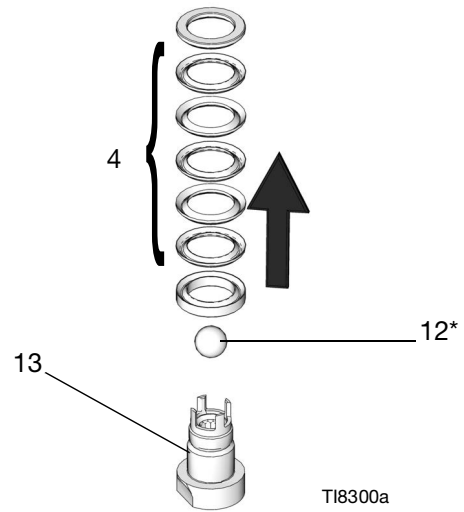

15. Clean all parts with a compatible solvent.

## Reassembly

1. Replace female gland on piston valve (13). Install the five v-packings (4) one at a time with lips facing up. Refer to the Packing Kits sections for the correct packing order for your lower. Install the male gland.

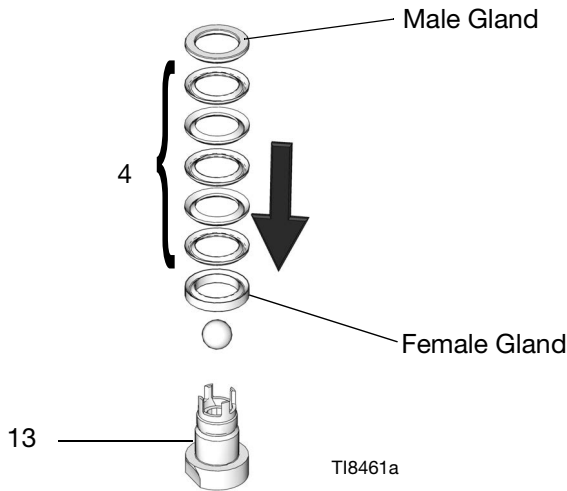

**NOTE:** To convert the lower to a different packing material, see the Packing Kits sections. For best results, soak leather packings in oil before reassembly.

2. Ensure there are no burrs or debris on mating threads of displacement rod (1) and piston valve (13). Apply anti-seize lubricant to threads and mating surfaces of displacement rod and piston valve.
3. Place flats of piston valve in a vise. Place piston ball (12\*) on piston valve.

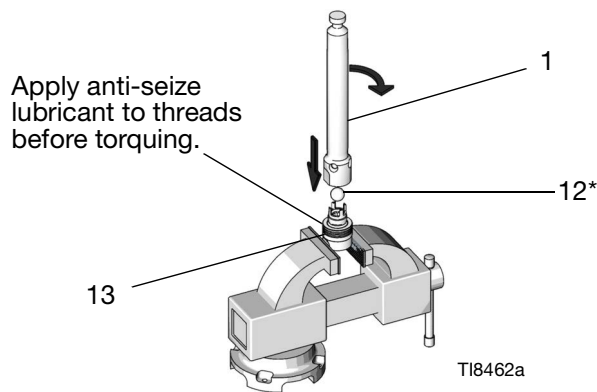

4. Screw displacement rod (1) onto piston valve (13), and hand tight. Then torque per table on page 13.

**NOTE:** Position crowfoot of torque wrench at a 90° angle to ensure accurate torque values.

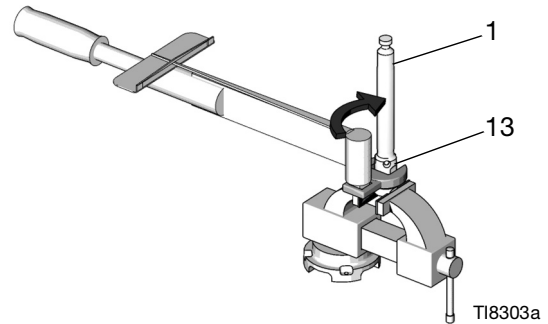

### NOTICE

To reduce the possibility of costly damage to displacement rod (1) and lower cylinder (11), first place lower cylinder on a soft block of wood. Always use a rubber mallet or an arbor press to drive the displacement rod into the lower cylinder. Never use a hammer to drive the rod.

5. To reinstall displacement rod (1) into lower cylinder (11), first lubricate piston packings (4). Then, with piston end facing down, lower rod into cylinder. Start piston into cylinder as much as possible, then drive rod and piston the rest of the way into the cylinder with an arbor press or rubber mallet.

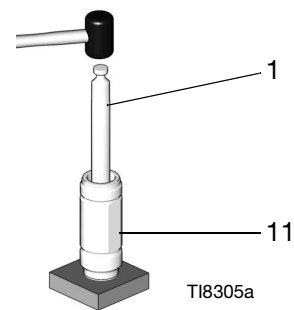

6. Lubricate inside of packing cartridge (7), outside threads of packing nut (2), and throat packings (3). Install packing cartridge into housing. Place male gland and spring in packing cartridge. Install the seven v-packings one at a time with lips facing down. Refer to the Packing Kits sections for the correct packing order for your lower. Install female gland. Then, reassemble packing nut (2), but do not tighten.

**NOTE:** To convert lower to a different packing material, see Packing Kits sections. For best results, soak leather packings in oil before reassembly.

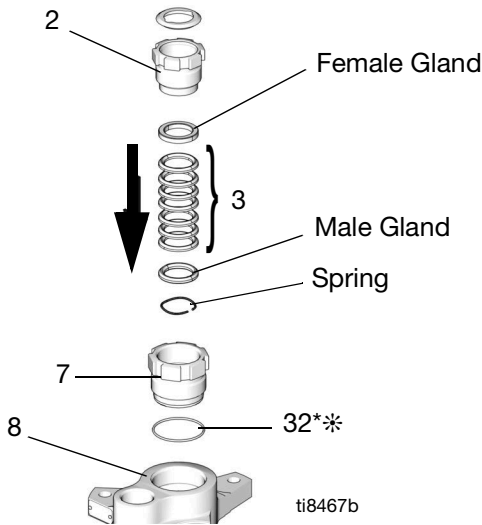

\*Blue o-ring for 220cc, 250cc, 290cc lowers.

7. Screw lower cylinder (11) onto outlet housing (8) until it bottoms out. Use a wrench to tighten lower cylinder. Back off as little as possible until hole in housing lines up with flat on cylinder. Insert locking pin (10) into cylinder.

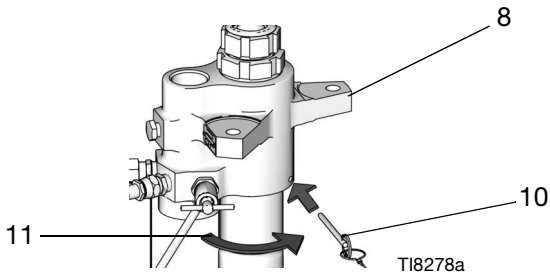

8. Assemble inlet housing.

- a. **For XP Lower 115cc and smaller:** Install seat (18), two shims (17), inlet ball (16), spring (43), and one o-ring (27) into inlet housing (14).

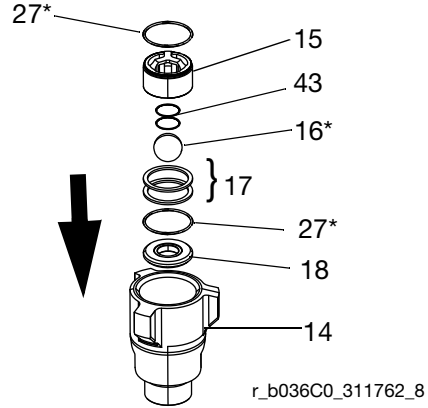

- b. **For XP Lower 145cc and larger:** Install seat (18), shim (17), inlet ball (16), spring (43), and one o-ring (27) into inlet housing (14).

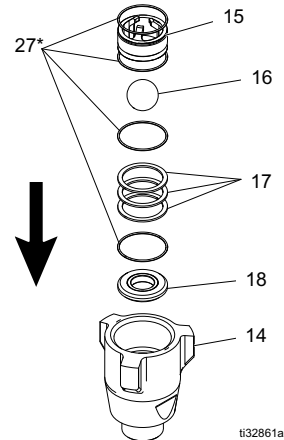

- c. **For Xtreme Lowers:** Install inlet seat (18), inlet ball (16), and one o-ring (27\*) into inlet housing (14).

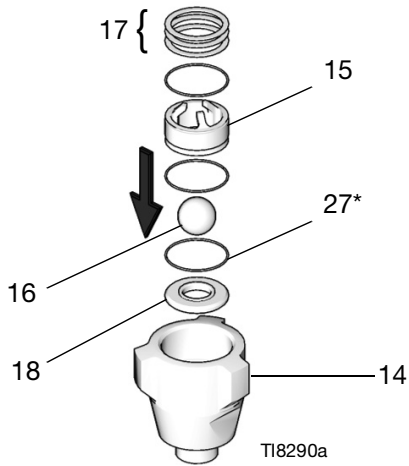

12. Thread inlet housing (14) onto lower cylinder (11). Torque to 140-150 ft-lb (189-203 N•m).

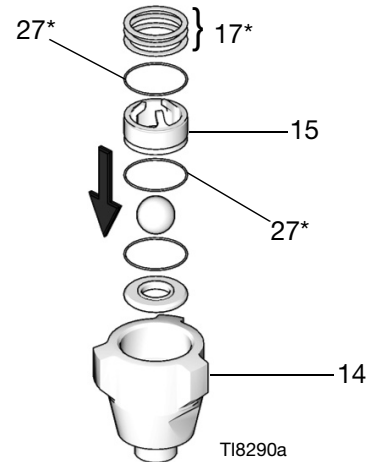

9. Lubricate and install o-rings (27\*) in top and bottom grooves of inlet ball guide (15).

10. **On model L180C7, L145CP and L145CR only,** install shims (17) into inlet housing (14), then press inlet ball guide (15) into inlet housing (14).

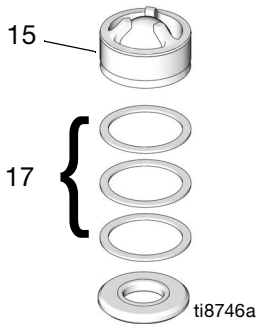

11. **On all models except L180C7,** press inlet ball guide (15) into inlet housing (14) and install shims (17).

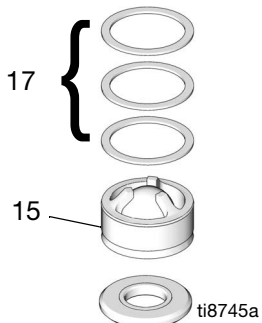

**NOTE:** Shims (three maximum) can be assembled either for short ball travel or long ball travel. See FIG. 4 for an example of each.

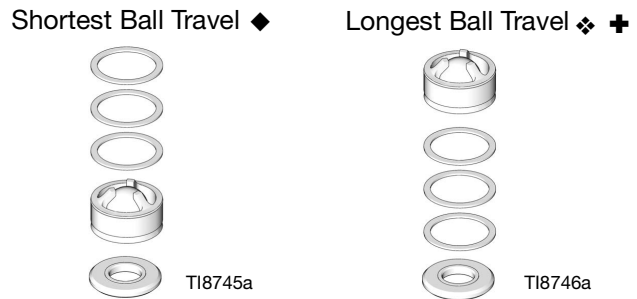

- ◆ *Factory set configuration or optimum pump change over.*
- ✦ *Shims can be configured to change ball travel length. Use longer ball travel length for higher viscosity fluids.*
- ✦ *Optional inlet ball spring kit available. Use to improve change over rate with longer ball travel configurations. See **Kits**, page 31, for more information.*

**FIG. 4: Shim Configuration for lowers without inlet spring**

13. Using torque wrench, torque packing cartridge (7) to outlet housing (8). Torque to 140-150 ft-lb (189-203 N•m).

14. Insert packings in correct orientation; see **Parts**, page 16. Install packing nut (2) and torque to the value in the table below.

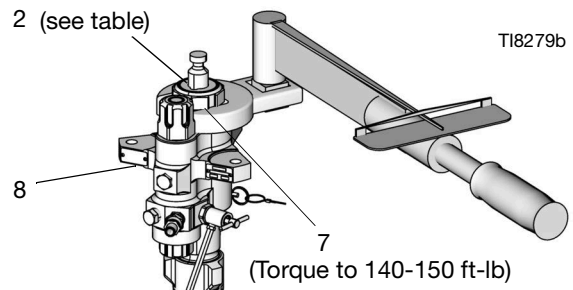

Required Torque

Pump	Throat Packing (2)	Piston Valve (13)
L036C0	70-80 ft-lb (95-108 N•m)	85 ft-lb (114 N•m)
L048C0	70-80 ft-lb (95-108 N•m)	
L054C0	70-80 ft-lb (95-108 N•m)	
L058C0	70-80 ft-lb (95-108 N•m)	
L072C0	70-80 ft-lb (95-108 N•m)	125 ft-lb (168 N•m)
L085C0 L085C1 L085C2 L085C3 L085C4	70-80 ft-lb (95-108 N•m)	
L090C0	70-80 ft-lb (95-108 N•m)	
L097C0	70-80 ft-lb (95-108 N•m)	
L115C0 L115C1 L115C2 L115C3 L115C4 L115C5 L115C6	70-80 ft-lb (95-108 N•m)	
L145C0 L145C1 L145C2 L145CL L145CN L145C8 L14AC1 L145M2 L145CP L145CR L145C3 L145C4	70-80 ft-lb (95-108 N•m)	
L180C0 L180C1 L180CL L180CN L180C2 L18AC1 L180M2 L180C3 L180C4 L180C7 L180C9	125 (168 N•m)	

Pump	Throat Packing (2)	Piston Valve (13)
L220C0 L220C1 L220C2 L22AC1 L22HC1 L22CH2 L22XC0 L220M2 L220C3 L220C4 L220C7 L220C9 L220CT	125 ft-lb (168 N•m)	200 ft-lb (269 N•m)
L250C0 L250C1 L250C2 L250C8 L25HC1 L25HC2 25A710 L250C3 L250C4 L25AC4	125 ft-lb (168 N•m)	
L290C0 L290C1 L290C2 L29AC1 L29HC1 L29HC2 L290M2 24N942 L290C3 L290C4 L290C7	125 ft-lb (168 N•m)	

15. For lowers with built-in filter, see **Service Built-in Filter**, page 14, if filter needs service. Then reinstall both top filter cap (20) and bottom filter cap (26).

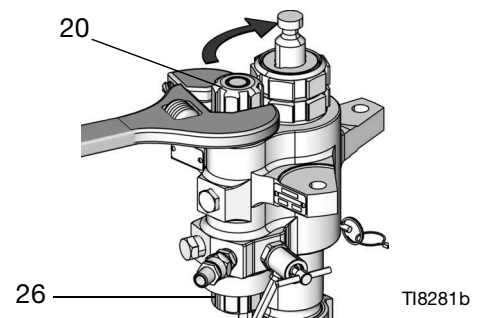

16. Reconnect lower to air motor. See your system manual, **Related Manuals**, page 2.

## Service Built-in Filter

Select models have a built-in filter in the lower housing.

### Disassembly

To remove and clean the built-in filter:

1. Follow the Pressure Relief Procedure detailed in your sprayer manual, **Related Manuals**, page 2.
2. Use wrench to loosen and remove top filter cap (20).

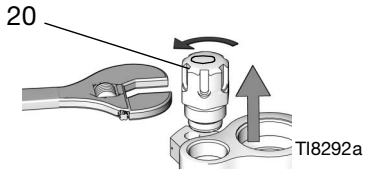

3. Remove o-ring (59\*), strainer (23), and filter support (24).

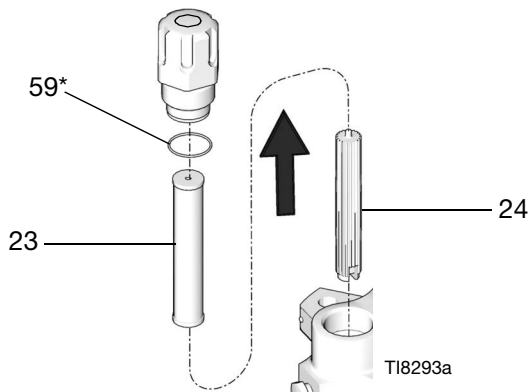

4. Use wrench to loosen and remove bottom filter cap (26). Remove o-rings (22\*, 25\*).

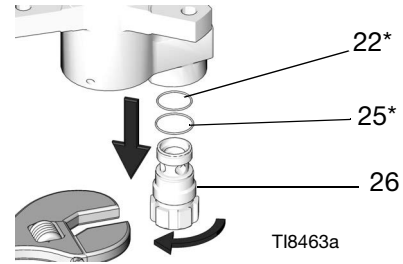

5. Replace o-rings (22\*, 25\*), strainer (23), and filter support (24).

**NOTE:** O-rings take a set at high pressures. Always replace the o-rings once the filter caps have been removed.

6. Remove pipe plug (49), and use brush or drill to clean port as necessary.

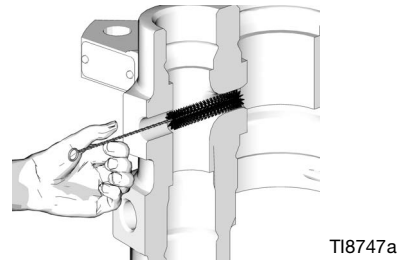

## Reassembly

### NOTICE

To prevent leaking, ensure that the proper repair components are used for the appropriate series pump. See **Filter Cap Repair Kit, 24F975**, page 32, for more information.

To reassemble the built-in filter:

**NOTE:** Lubricate all o-rings before installation.

1. Install o-rings (22\*, 25\*) onto bottom filter cap (26). Then use wrench to reassemble and tighten bottom filter cap. Torque to 40-60 ft-lb (52-82 N•m).

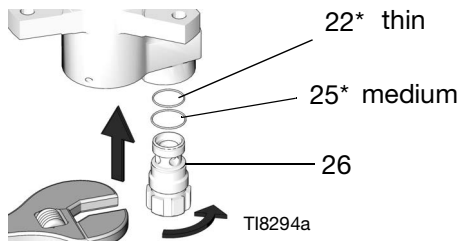

2. Reassemble o-ring (59\*) onto top filter cap (20). Install strainer (23), and filter support (24) in top filter cap. Then use wrench to install and tighten top filter cap. Torque to 40-60 ft-lb (52-82 N•m).

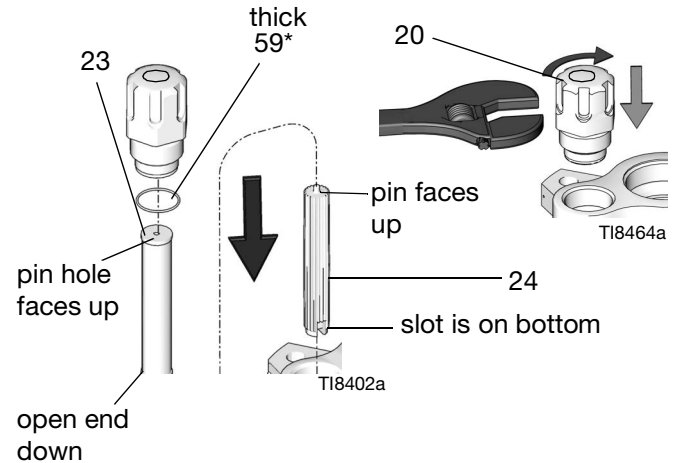

**NOTE:** 36cc through 115cc Xtreme pump lowers no longer use the short filter screens (23) or supports (24). See page 32 for details.

# Parts

## XP Sprayer Lower Models

36cc, 48cc, 54cc, 58cc, 72cc, 85cc, 90cc, 97cc, and 115cc

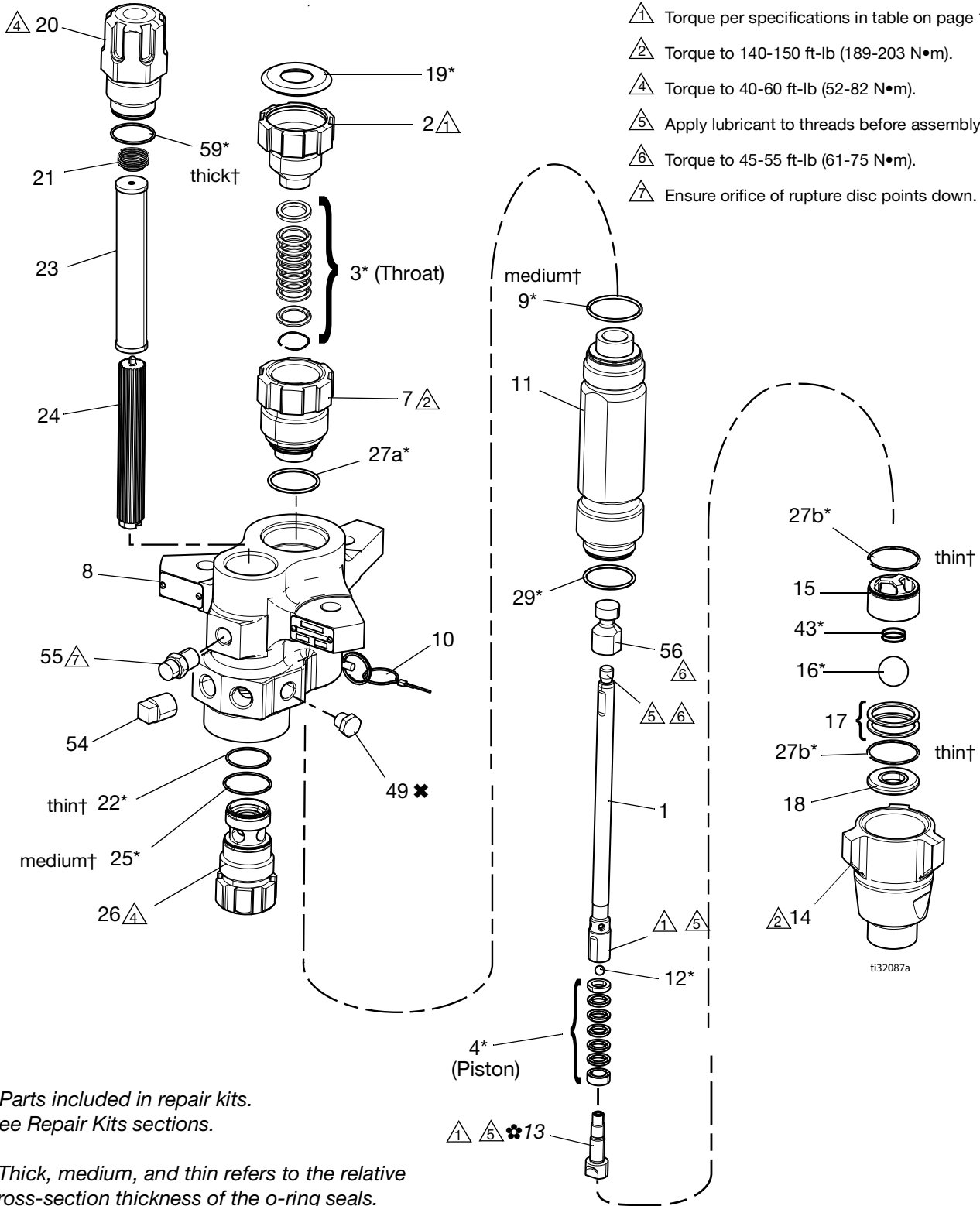

\* Parts included in repair kits.  
See Repair Kits sections.

†Thick, medium, and thin refers to the relative cross-section thickness of the o-ring seals.



## 36cc, 48cc, 54cc, 58cc, and 72cc XP Models

Ref.	Descriptions	36cc	48cc	54cc	58cc	72cc	Qty.
		L036C0	L048C0	L054C0	L058C0	L072C0	
1	ROD, displacement	16D458	16D459	16J900	16D460	16J901	1
2	NUT, packing	16D468	16D468	16D468	16D468	15K029	1
3*	PACKINGS, stack; throat	See <b>Repair Kits</b> starting on page 27.					1
4*	PACKINGS, stack; piston	See <b>Repair Kits</b> starting on page 27.					1
7	CARTRIDGE, packing, throat	16D467	16D467	16D467	16D467	16K490	1
8	HOUSING, outlet	15F659	15F659	15F659	15F659	15F659	1
9*	O-RING, top cylinder; PTFE, medium (10 pack)	288067	288067	288067	288067	288067	1
10	PIN, self-locking	244826	244826	244826	244826	244826	1
11	CYLINDER, lower	16D469	16D470	16J906	16D471	16J907	1
12*	BALL, piston (pack of 3)	262485	262485	262485	262485	262741	1
13	VALVE, piston	16D464	16D464	16D464	16D464	16K068	1
14	HOUSING, inlet	15F667	15F667	15F667	15F667	15F667	1
15	GUIDE, ball, inlet	16D472	16D472	16D472	16D472	16D472	1
16*	BALL, inlet (pack of 3)	244899	244899	244899	244899	244899	1
17	SHIM, inlet, ball guide (pack of 9)	288064	288064	288064	288064	288064	2
18	SEAT, inlet	15F665	15F665	15F665	15F665	15F665	1
19*	PLUG, throat seal (pack of 10)	247393	247393	247393	247393	247393	1
20†	CAP, filter, top	16M461	16M461	16M461	16M461	16M461	1
21	SPRING, compression	171941	171941	171941	171941	171941	1
22*†	O-RING, filter; thin, PTFE (10 pack)	244895	244895	244895	244895	244895	1
23	STRAINER, 30 mesh screen; see page 31 for more options	224458	224458	224458	224458	224458	1
24	SUPPORT, filter	186075	186075	186075	186075	186075	1
25*†	O-RING, filter; medium, PTFE (10 pack)	262484	262484	262484	262484	262484	1
26†	CAP, filter	16M462	16M462	16M462	16M462	16M462	1
27a*	O-RING, PTFE, throat cartridge, medium (10 pack)	262512	262512	262512	262512	262512	1
27b*	O-RING; foot valve, PTFE, thin (pack of 10)	288068	288068	288068	288068	288068	2
29*	O-RING; cylinder bottom, PTFE, medium (pack of 10)	262512	262512	262512	262512	262512	1
30▲	TAG, warning	172479	172479	172479	172479	172479	1
43	SPRING, foot valve	124007	124007	124007	124007	124007	1
49	PLUG, pipe; 3/8 npt	198292	198292	198292	198292	198292	1
54	PLUG, pipe; 1/2 in.	100737	100737	100737	100737	100737	1
55	HOUSING, rupture disc assy	258962	258962	258962	258962	258962	1
56	ADAPTER, rod	15Y399	15Y399	15Y399	15Y399	15Y399	1
59*†	O-RING, filter; thick, PTFE (10 pack)	262483	262483	262483	262483	262483	1
61	COUPLER, assembly	247167	247167	247167	247167	247167	1

▲ Replacement safety labels, tags, and cards are available at no cost.

\* Parts included in repair kits.

† See page 32 to verify correct part numbers.

Part numbers listed are for bulk quantities. Individual quantities are included in repair kits. See **Repair Kits** starting on page 27.

**85cc, 90cc, 97cc, and 115cc XP Models**

Ref.	Descriptions	85cc	90cc	97cc	115cc	Qty.
		L085C0	L090C0	L097C0	L115C0	
1	ROD, displacement	24B819	16J902	16J903	•	1
2	NUT, packing	15K029	15K029	15K029	15K029	1
3*	PACKINGS, stack; throat	See <b>Repair Kits</b> starting on page 27.				1
4*	PACKINGS, stack; piston	See <b>Repair Kits</b> starting on page 27.				1
7	CARTRIDGE, packing, throat	15F660	16K490	16K490	15F661	1
8	HOUSING, outlet	15F659	15F659	15F659	15F659	1
9*	O-RING, top cylinder; PTFE, medium (10 pack)	288067	288067	288067	288067	1
10	PIN, self-locking	244826	244826	244826	244826	1
11	CYLINDER, lower	15F682	16J908	16J909	•	1
12*	BALL, piston (pack of 3)	288065	288065	288065	•	1
13	VALVE, piston	24B818	24B818	24B818	•	1
14	HOUSING, inlet	15F667	15F667	15F667	•	1
15	GUIDE, ball, inlet	16D472	16D472	16D472	•	1
16*	BALL, inlet (pack of 3)	244899	244899	244899	•	1
17	SHIM, inlet, ball guide (pack of 9)	288064	288064	288064	•	2
18	SEAT, inlet	15F665	15F665	15F665	•	1
19*	PLUG, throat seal (pack of 10)	247393	247393	247393	247393	1
20†	CAP, filter, top	16M461	16M461	16M461	16M461	1
21	SPRING, compression	171941	171941	171941	171941	1
22*†	O-RING, filter; thin, PTFE (10 pack)	244895	244895	244895	244895	1
23	STRAINER, 30 mesh screen; see page 31 for more options	224458	224458	224458	224458	1
24	SUPPORT, filter	186075	186075	186075	186075	1
25*†	O-RING, filter; medium, PTFE (10 pack)	262484	262484	262484	262484	1
26†	CAP, filter	16M462	16M462	16M462	16M462	1
27a*	O-RING, PTFE, throat cartridge (10 pack) 262512 medium, 288068 thin	288068	262512	262512	288068	1
27b*	O-RING; foot valve, PTFE, thin (pack of 10)	288068	288068	288068	•	2
29*	O-RING; cylinder bottom, PTFE (pack of 10) 262512 medium, 288068 thin	288068	262512	262512	•	1
30▲	TAG, warning	172479	172479	172479	172479	1
43	SPRING, foot valve	124007	124007	124007	•	1
49	PLUG, pipe; 3/8 npt	198292	198292	198292	198292	1
54	PLUG, pipe; 1/2 in.	100737	100737	100737	100361	1
55	HOUSING, rupture disc assembly	258962	258962	258962	258962	1
56	ADAPTER, rod					1
59*†	O-RING, filter; thick, PTFE (10 pack)	262483	262483	262483	262483	1

▲ Replacement safety labels, tags, and cards are available at no cost.

\* Parts included in repair kits.

• Depends on series. See manual 406889.

† See page 32 to verify correct part numbers.

Part numbers listed are for bulk quantities. Individual quantities are included in repair kits. See **Repair Kits** starting on page 27.

# XP Sprayer Lower Models 145cc, 180cc, 220cc, 250cc, and 290cc

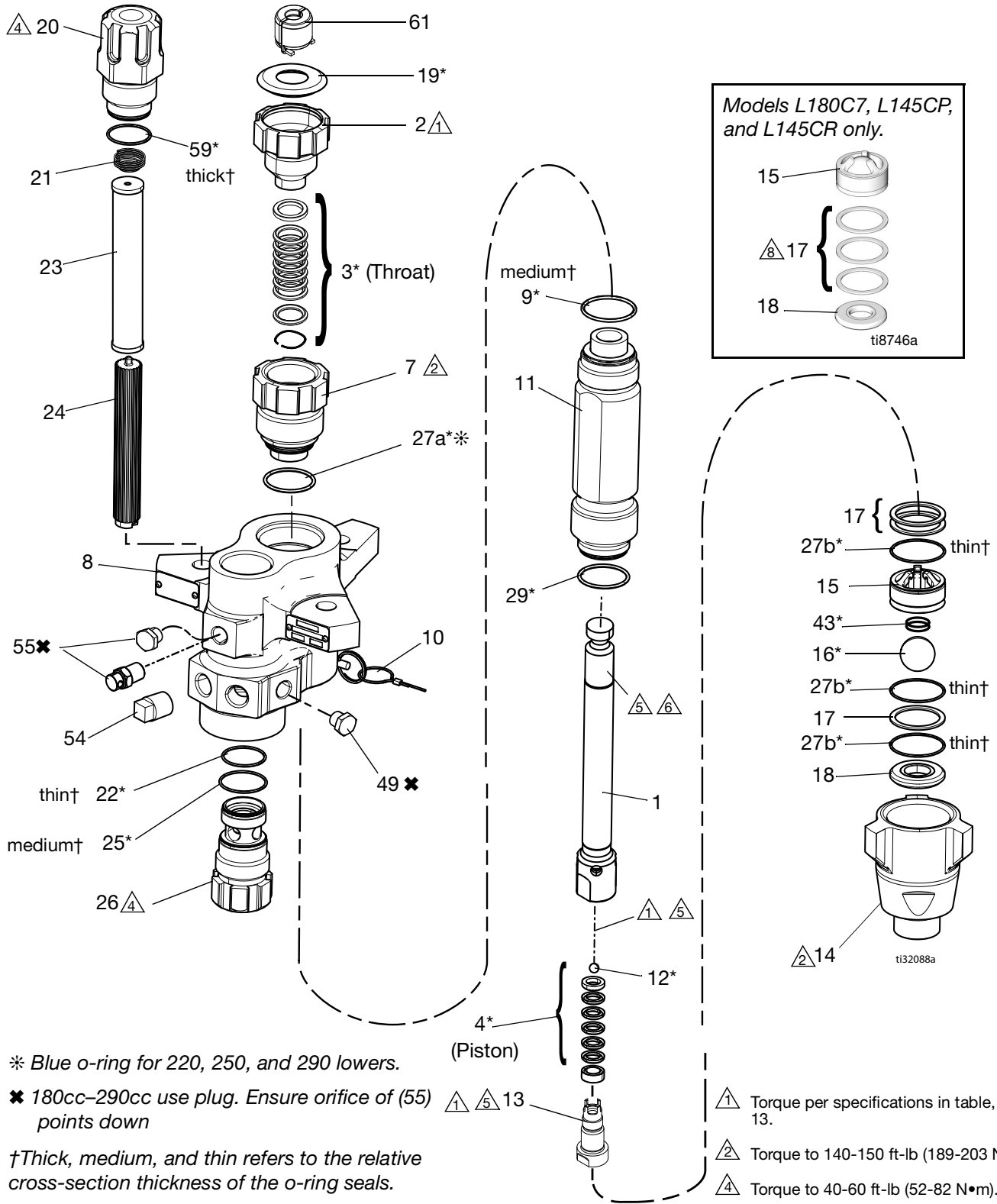

\* Blue o-ring for 220, 250, and 290 lowers.

✱ 180cc-290cc use plug. Ensure orifice of (55) points down

†Thick, medium, and thin refers to the relative cross-section thickness of the o-ring seals.

\* Parts included in repair kits. See Repair Kits sections.

1 Torque per specifications in table, page 13.

2 Torque to 140-150 ft-lb (189-203 N•m).

4 Torque to 40-60 ft-lb (52-82 N•m).

5 Apply lubricant to threads before assembly.

6

## 145cc, 180cc, 220cc, 250cc, and 290cc XP Models

Ref.	Descriptions	145cc	180cc	220cc	220cc	250cc	290cc	Qty.
		L14AC0	L18AC0	L22AC0	L22XC0	L25AC0	L29AC0	
1	ROD, displacement	24B821	24B822	24B823	26A377	24B824	24B825	1
2	NUT, packing	15K030	15K030	15K031	15K031	15K031	15K031	1
3*	PACKINGS, stack; throat	See <b>Repair Kits</b> starting on page 27.						1
4*	PACKINGS, stack; piston	See <b>Repair Kits</b> starting on page 27.						1
7	CARTRIDGE, packing, throat	197325	197326	197327	197327	197328	197327	1
8	HOUSING, outlet	16E151	16E151	16A763	16A763	16A763	16A763	1
9*	O-RING, top cylinder; PTFE, medium (10 pack)	244892	244892	244893	244893	244893	244893	1
10	PIN, self-locking	244826	244826	244826	244826	244826	244826	1
11	CYLINDER, lower	197315	197316	197317	197317	197318	197319	1
12*	BALL, piston (pack of 3)	253029	253029	244898	244898	244898	244899	1
13	VALVE, piston	24B826	24B827	24B828	24B828	24B829	24B830	1
14	HOUSING, inlet	197303	197303	197304	197304	197304	197304	1
15	GUIDE, ball, inlet	198646	198646	198647	198647	198647	198647	1
16*	BALL, inlet (pack of 3)	245128	245128	253030	253030	253030	253030	1
17	SHIM, inlet, ball guide (pack of 9)	244855	244855	244856	244856	244856	244856	3
18	SEAT, inlet	196358	196358	197344	197344	197344	197344	1
19*	PLUG, throat seal (pack of 10)	247394	247394	247395	247395	247395	247395	1
20†	CAP, filter, top	16M461	16M461	16M461	16M461	16M461	16M461	1
21	SPRING, compression	171941	171941	171941	171941	171941	171941	1
22*†	O-RING, filter; thin, PTFE (10 pack)	244895	244895	244895	244895	244895	244895	1
23	STRAINER, 30 mesh screen; see page 31 for more options	224458	224458	224458	224458	224458	224458	1
24	SUPPORT, filter	186075	186075	186075	186075	186075	186075	1
25*†	O-RING, filter; medium, PTFE (10 pack)	262484	262484	262484	262484	262484	262484	1
26†	CAP, filter	16M462	16M462	16M462	16M462	16M462	16M462	1
27a*	O-RING, PTFE, throat cartridge, thin (10 pack)	244890	244890	244891	244891	244891	244891	1
27b*	O-RING; foot valve, PTFE, thin (pack of 10)	244890	244890	244894	244894	244894	244894	3
29*	O-RING; cylinder bottom, PTFE, thin (pack of 10)	244890	244890	244894	244894	244894	244894	1
30▲	TAG, warning	172479	172479	172479	172479	172479	172479	1
43	SPRING, foot valve	116801	116801	116802	116802	116802	116802	1
49	PLUG, pipe; 3/8 npt	198292	198292	198292	198292	198292	198292	1
54	PLUG, pipe; 1/2 in.	100737	100737	100737	100737	100737	100737	1
55	PLUG, pipe; 3/8 npt		198292	198292	198292	198292	198292	1
	HOUSING, rupture disc assembly	258962						1
59*†	O-RING, filter; thick, PTFE (10 pack)	262483	262483	262483	262483	262483	262483	1
61	COUPLER, assembly	244819	244819	244819	244819	244819	244819	1

▲ Replacement safety labels, tags, and cards are available at no cost.

\* Parts included in repair kits.

† See page 32 to verify correct part numbers.

Part numbers listed are for bulk quantities. Individual quantities are included in repair kits. See **Repair Kits** starting on page 27.

# Xtreme, e-Xtreme, and King Sprayer Lower Models 85cc 115cc, 145cc, 180cc, 220cc, 250cc, and 290cc

 Torque per table on page 13.

 Torque to 140-150 ft-lb (189-203 N•m).

 Torque to 40-60 ft-lb (52-82 N•m).

 Apply lubricant to threads before assembly.

7. Thick, medium, and thin refers to the relative cross-section thickness of the o-ring seals.

 On models L180C7, L145CP, and L145CR only, all 3 shims (17) are installed together between inlet seat (18) and inlet ball guide (15).

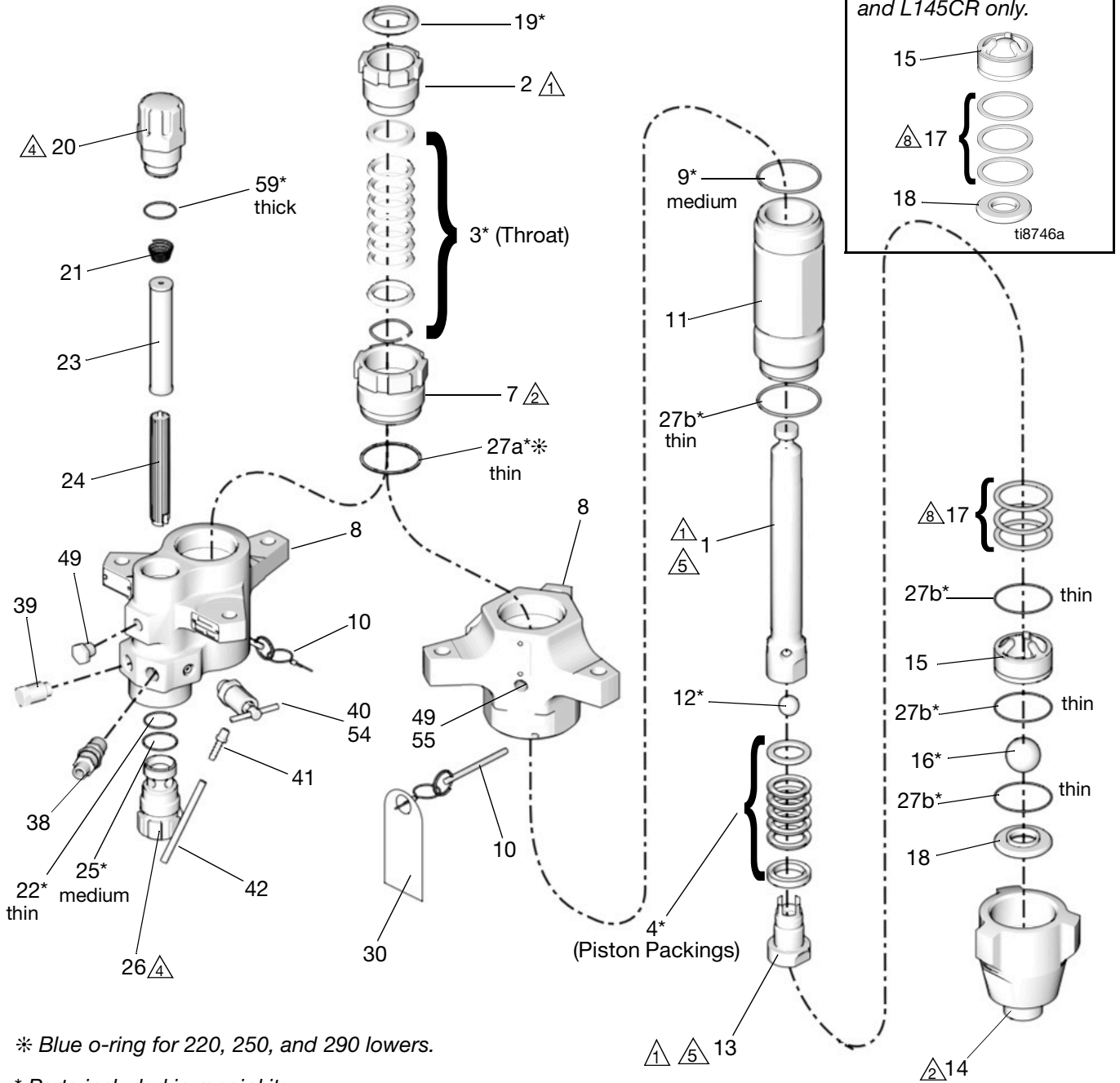

## 85cc and 115cc Models

Ref.	Descriptions	85cc		115cc				Qty.
		L085C1 L085C3	L085C2 L085C4	L115C1 L115C3	L115C2 L115C4	L115C5	L115C6	
1	ROD, displacement	24B819	24B819	See manual 406889		273270	273270	1
2	NUT, packing	15K029	15K029	15K029	15K029	15K029	15K029	1
3*	PACKINGS, stack; throat	See <b>Repair Kits</b> starting on page 27.						1
4*	PACKINGS, stack; piston	See <b>Repair Kits</b> starting on page 27.						1
7	CARTRIDGE, packing, throat	15F660	15F660	15F661	15F661	15F661	15F661	1
8	HOUSING, outlet	15F654	15F659	15F654	15F659	15F659	15F654	1
9*	O-RING, top cylinder; PTFE, medium (pack of 10)	288067	288067	288067	288067	288067	288067	1
10	PIN, self-locking	244826	244826	244826	244826	244826	244826	1
11	CYLINDER, lower	15F682	15F682	See manual 406889		19B776	19B776	1
12*	BALL, piston; (pack of 3)	288065	288065			253029	253029	1
13	VALVE, piston	24B818	24B818			273271	273271	1
14	HOUSING, inlet	15F667	15F667			197303	197303	1
15	GUIDE, ball, inlet	15F664	15F664			197307	197307	1
16*	BALL, inlet; (pack of 3)	244899	244899			245128	245128	1
17	SHIM, inlet, ball guide (pack of 9)	288064	288064			244855	244855	3
18	SEAT, inlet	15F665	15F665			196358	196358	1
19*	PLUG, throat seal (pack of 10)	247393	247393	247393	247393	247393	247393	1
20†	CAP, filter, top		16M461		16M461	16M461		1
21	SPRING, compression		171941		171941	171941		1
22*†	O-RING, filter; thin, PTFE (10 pack)		244895		244895	244895		1
23	STRAINER, 60 mesh screen; see page 31 for more options		224459		224459	224459		1
24	SUPPORT, filter		186075		186075	186075		1
25*†	O-RING, filter; medium, PTFE (10 pack)		262484		262484	262484		1
26†	CAP, filter, lower		16M462		16M462	16M462		1
27a*	O-RING; throat cartridge, PTFE, thin (pack of 10)	288068	288068	288068	288068	288068	288068	1
27b*	O-RING, PTFE, foot valve and cylinder bottom, thin (10 pack)	288068	288068	See 406889 Manual		244890	244890	4
30▲	TAG, warning	172479	172479	172479	172479	172479	172479	1
38	FITTING, nipple, outlet 1/2 in.		158491		158491			1
39	PLUG, packless; 1/2 in.		24N518		24N518	100362		1
40	VALVE, pressure dump		245143		245143			1
41	FITTING, barbed, plated		116746		116746			1
42	TUBE, nylon		116750		116750			1
49	PLUG, pipe	101754	198292	101754	198292	198292		1
54	HOUSING, rupture, disc					258962		1
55	HOUSING, rupture, disc						258962	1
59†	O-RING, filter; thick, PTFE (10 pack)		262483		262483	262483		1

▲ Replacement safety labels, tags, and cards are available at no cost.

\* Parts included in repair kits.

† See page 32 to verify correct part numbers.

Part numbers listed are for bulk quantities. Individual quantities are included in repair kits. See **Repair Kits** starting on page 27.

## 145cc Models

Ref.	Descriptions	145cc									Qty.
		L145C1 L145C3 L145CP	L145C2 L145C4 L145CR	L145C8	L14AC1	L145M2	L145CL	L145CN	L145C5	L145C6	
1	ROD, displacement	24B821	24B821	24B821	24B821	25D349	24B821	24B821	24B821	24B821	1
2	NUT, packing	15K030	15K030	15K030	15K030	15K030	15K030	15K030	15K030	15K030	1
3*	PACKINGS, stack; throat	See <b>Repair Kits</b> starting on page 27.									1
4*	PACKINGS, stack; piston	See <b>Repair Kits</b> starting on page 27.									1
7	CARTRIDGE, packing, throat	197325	197325	197325	197325	197325	197325	197325	197325	197325	1
8	HOUSING, outlet	197334	197336	197334	15J673	197336	197336	197334	197336	197334	1
9*	O-RING, top cylinder; PTFE, medium (pack of 10)	244892	244892	244892	244892	244892	244892	244892	244892	244892	1
10	PIN, self-locking	244826	244826	244826	244826	244826	244826	244826	244826	244826	1
11	CYLINDER, lower	197315	197315	197315	197315	17S911	197315	197315	197315	197315	1
12*	BALL, piston; (pack of 3)	253029	253029	253029	253029	253029	253029	253029	253029	253029	1
13	VALVE, piston	24B826	24B826	24B826	24B826	24B826	24B826	24B826	24B826	24B826	1
14	HOUSING, inlet	197303	197303	197303	197303	197303	25C241	25C241	197303	197303	1
15	GUIDE, ball, inlet	197307	197307	197307	197307	197307	197307	197307	197307	197307	1
16*	BALL, inlet; (pack of 3)	245128	245128	245128	245128	245178	245128	245128	245128	245128	1
17	SHIM, inlet, ball guide (pack of 9)	244855	244855	244855	244855	244855	244855	244855	244855	244855	3
18	SEAT, inlet	196358	196358	196358	196358	196358	196358	196358	196358	196358	1
19*	PLUG, throat seal (pack of 10)	247394	247394	247394	247394	243304	247394	247394	247394	247394	1
20†	CAP, filter, top		16M461			16M461	16M461		16M461		1
21	SPRING, compression		171941			171941	171941		171941		1
22*	O-RING, filter; thin, PTFE (10 pack)		244895			244895	244895		244895		1
23	STRAINER, 60 mesh screen; (2 pack) see page 31 for more options		224459			224459	224459		224459		1
24	SUPPORT, filter		186075			186075	186075		186075		1
25*†	O-RING, filter; medium, PTFE (10 pack)		262484			262484	262484		262484		1
26†	CAP, filter		16M462			16M462	16M462		16M462		1
27a*	O-RING; throat cartridge, PTFE, thin (pack of 10)	244890	244890	244890	244890	244890	244890	244890	244890	244890	1
27b*	O-RING, PTFE, foot valve and cylinder bottom, thin (10 pack)	244890	244890	244890	244890	244890	244890	244890	244890	244890	4
30▲	TAG, warning	172479	172479	172479	172479	172479	172479	172479	172479	172479	1
38	FITTING, nipple, outlet 1/2 in.		158491			158491					1
39	PLUG, packless; 1/2 in.		24N518			24N518	100362		100362		1
40	VALVE, pressure dump		245143			245143					1
41	FITTING, barbed, plated		116746			116746					1
42	TUBE, nylon		116750			116750					1
49	PLUG, pipe	101754	198292		101754	198292	198292		198292		1
54	HOUSING, rupture disc						258962		258962		1
55	HOUSING, rupture disc			127628				127628		127628	1
59†	O-RING, filter; thick, PTFE (10 pack)		262483			262483	262483		262483		1

▲ Replacement safety labels, tags, and cards are available at no cost.

\* Parts included in repair kits.

† See page 32 to verify correct part numbers.

Part numbers listed are for bulk quantities. Individual quantities are included in repair kits. See **Repair Kits** starting on page 27.

## 180cc Models

Ref.	Descriptions	180cc							Qty.
		L180C1 L180C3 L180C7	L180C9	L180C2 L180C4	L18AC1	L180CL	L180CN	L180M2	
1	ROD, displacement	24B822	24B822	24B822	24B822	24B822	24B822	25D350	1
2	NUT, packing	15K030	15K030	15K030	15K030	15K030	15K030	15K030	1
3*	PACKINGS, stack; throat	See <b>Repair Kits</b> starting on page 27.							1
4*	PACKINGS, stack; piston	See <b>Repair Kits</b> starting on page 27.							1
7	CARTRIDGE, packing, throat	197326	197326	197326	197326	197326	197326	197326	1
8	HOUSING, outlet	197334	197334	197336	15J673	197336	197334	197336	1
9*	O-RING, top cylinder; PTFE, medium (10 pack)	244892	244892	244892	244892	244892	244892	244892	1
10	PIN, self-locking	244826	244826	244826	244826	244826	244826	244826	1
11	CYLINDER, lower	197316	197316	197316	197316	197316	197316	17S912	1
12*	BALL, piston; (pack of 3)	253029	253029	253029	253029	253029	253029	253029	1
13	VALVE, piston	24B827	24B827	24B827	24B827	24B827	24B827	24B827	1
14	HOUSING, inlet	197303	197303	197303	197303	25C241	25C241	197303	1
15	GUIDE, ball, inlet	197307	197307	197307	197307	197307	197307	197307	1
16*	BALL, inlet; (pack of 3)	245128	245128	245128	245128	245128	245128	245128	1
17	SHIM, inlet, ball guide (pack of 9)	244855	244855	244855	244855	244855	244855	244855	3
18	SEAT, inlet	196358	196358	196358	196358	196358	196358	196358	1
19*	PLUG, throat seal (pack of 10)	247394	247394	247394	247394	247394	247394	247394	1
20†	CAP, filter, top			16M461		16M461		16M461	1
21	SPRING, compression			171941		171941		171941	1
22*	O-RING, filter; thin, PTFE (10 pack)			244895		244895		244895	1
23	STRAINER, 60 mesh screen; (2 pack) see page 31 for more options			224459		224459		224459	1
24	SUPPORT, filter			186075		186075		186075	1
25*†	O-RING, filter; medium, PTFE (10 pack)			262484		262484		262484	1
26†	CAP, filter			16M462		16M462		16M462	1
27a*	O-RING; throat cartridge, PTFE, thin (10 pack)	244890	244890	244890	244890	244890	244890	244890	1
27b*	O-RING, foot valve and cylinder bottom, PTFE, thin (10 pack)	244890	244890	244890	244890	244890	244890	244890	4
30▲	TAG, warning	172479	172479	172479	172479	172479	172479	172479	1
38	FITTING, nipple, outlet 1/2 in.			158491				158491	1
39	PLUG, packless; 1/2 in.			24N518		100362		24N518	1
40	VALVE, pressure dump			245143				245143	1
41	FITTING, barbed, plated			116746				116746	1
42	TUBE, nylon			116750				116750	1
49	PLUG, pipe	101754		198292	101754	198292		198292	1
54	HOUSING, rupture disc					258962	127628		1
55	HOUSING, rupture disc		258962						1
59†	O-RING, filter; thick, PTFE (10 pack)			262483		262483			1

▲ Replacement safety labels, tags, and cards are available at no cost.

\* Parts included in repair kits.

† See page 32 to verify correct part numbers.

Part numbers listed are for bulk quantities. Individual quantities are included in repair kits. See **Repair Kits** starting on page 27.



**220cc and 250cc Models**

Ref.	Descriptions	220cc										250cc					Qty.	
		L220C1 L220C3	L220C2 L220C4	L220C7	L220C9	L220CT	L22AC1	L22HC1	L22HC2	L220M2	L250C1 L250C3	L250C2 L250C4	L250C8	L25HC1	L25HC2	25A710		
1	ROD, displacement	24B823	24B823	24B823	24B823	24B823	24B823	24X554	24X554	25D351	24B824	24B824	24B824	24X555	24X555	24B824	1	
2	NUT, packing	15K031	15K031	15K031	15K031	15K031	15K031	15K031	15K031	15K031	15K031	15K031	15K031	15K031	15K031	15K031	1	
3*	PACKINGS, stack; throat	See <b>Repair Kits</b> starting on page 27.														1		
4*	PACKINGS, stack; packing	See <b>Repair Kits</b> starting on page 27.														1		
7	CARTRIDGE, packing, throat	197327	197327	197327	197327	197327	197327	197327	197327	197327	197328	197328	197328	197328	197328	197328	1	
8	HOUSING, outlet	197335	197337	197335	197335	197335	15H722	197335	17D828	197337	197335	197337	197335	197335	17D828	197335	1	
9	O-RING, top cylinder; PTFE, medium (pack of 10)	244893	244893	244893	244893	244893	244893	244893	244893	244893	244893	244893	244893	244893	244893	244893	1	
10	PIN, self-locking	244826	244826	244826	244826	244826	244826	244826	244826	244826	244826	244826	244826	244826	244826	244826	1	
11	CYLINDER, lower	197317	197317	197317	197317	197317	197317	17C109	17C109	17S913	197318	197318	197318	17C110	17C110	197318	1	
12*	BALL, piston; (pack of 3)	244898	244898	244898	244898	244898	244898	244898	244898	244898	244898	244898	244898	244898	244898	244898	1	
13	VALVE, piston	24B828	24B828	24B828	24B828	26D671	24B828	24B828	24B828	24B828	24B829	24B829	24B829	24B829	24B829	24B829	1	
14	HOUSING, inlet	197304	197304	197304	197304	197304	197304	17C167	17C167	197304	197304	197304	197304	17C167	17C167	197304	1	
15	GUIDE, ball, inlet	198647	198647	198647	198647	198647	198647	198647	198647	198647	198647	198647	198647	198647	198647	198647	1	
16*	BALL, inlet; (pack of 3)	253030	253030	253030	253030	253030	253030	253030	253030	253030	253030	253030	253030	253030	253030	253030	1	
17	SHIM, inlet, ball guide (pack of 9)	244856	244856	244856	244856	244856	244856	244856	244856	244856	244856	244856	244856	244856	244856	244856	3	
18	SEAT, inlet	197344	197344	197344	197344	15N533	197344	197344	197344	197344	197344	197344	197344	197344	197344	197344	17E318	1
19*	PLUG, throat seal (pack of 10)	247395	247395	247395	247395	247395	247395	247395	247395	247395	247395	247395	247395	247395	247395	247395	1	
20†	CAP, filter, top		16M461						16M461	16M461		16M461			16M461		1	
21	SPRING, compression		171941						171941	171941		171941			171941		1	
22*†	O-RING, filter; thin, PTFE (10 pack)		244895						244895	244895		244895			244895		1	
23	STRAINER, 60 mesh screen (2 pack); see page 31 for more options		224459						224459	224459		224459			224459		1	
24	SUPPORT, filter		186075						186075	186075		186075			186075		1	
25*†	O-RING, filter; medium, PTFE (10 pack)		262484						262484	262484		262484			262484		1	
26†	CAP, filter		16M462						16M462	16M462		16M462			16M462		1	
27a* *	O-RING; throat cartridge, PTFE, blue, thin (pack of 10)	244891	244891	244891	244891	244891	244891	244891	244891	244891	244891	244891	244891	244891	244891	244891	1	
27b*	O-RING, PTFE, foot valve and cylinder bottom, thin (10 pack)	244894	244894	244894	244894	244894	244894	244894	244894	244894	244894	244894	244894	244894	244894	244894	4	
30▲	TAG, warning	172479		172479	172479	172479	172479	172479	172479	172479	172479	172479	172479	172479	172479	172479	1	
38	FITTING, nipple, outlet 1/2 in.		158491						158491	158491		158491			158491		1	
39	PLUG, packless; 1/2 in.		24N518						24N518	24N518		24N518			24N518		1	
40	VALVE, pressure dump		245143						245143	245143		245143			245143		1	
41	FITTING, barbed, plated		116746						116746	116746		116746			116746		1	
42	TUBE, nylon		116750						116750	116750		116750			116750		1	
49	PLUG, pipe	101754	198292	101754			101754	101754	198292	198292	101754	198292			198292		1	
55	HOUSING, rupture disc				258962	258962							258962			258962	1	
59*†	O-RING, filter; thick, PTFE (10 pack)		262483						262483	262483		262483			262483		1	

▲ Replacement safety labels, tags, and cards are available at no cost.

† See page 32 to verify correct part numbers.

\* Parts included in repair kits.

Part numbers listed are for bulk quantities. Individual quantities are included in repair kits. See **Repair Kits** starting on page 27.

\* Blue o-ring for 220, 250, and 290 lowers.

## 290cc Models

Ref.	Descriptions	290cc								Qty.
		24N942	L290C1 L290C3	L290C2 L290C4	L290C7	L29AC1	L29HC1	L29HC2	L290M2	
1	ROD, displacement	16R994	24B825	24B825	24B825	24B825	24X556	24X556	25D352	1
2	NUT, packing	15K031	15K031	15K031	15K031	15K031	15K031	15K031	15K031	1
3*	PACKINGS, stack. throat	See <b>Repair Kits</b> , starting on page 27.								1
4*	PACKINGS, stack; piston	See <b>Repair Kits</b> , starting on page 27.								1
7	CARTRIDGE, packing, throat	197327	197327	197327	197327	197327	197327	197327	197327	1
8	HOUSING, outlet	197335	197335	197337	197335	15H722	197335	17D828	197337	1
9*	O-RING, top cylinder; PTFE, medium (pack of 10)	244893	244893	244893	244893	244893	244893	244893	244893	1
10	PIN, self-locking	244826	244826	244826	244826	244826	244826	244826	244826	1
11	CYLINDER, lower	197319	197319	197319	17C111	197319	17C111	17C111	17S915	1
12*	BALL, piston; (pack of 3)	244899	244899	244899	244899	244899	244899	244899	244899	1
13	VALVE, piston	24B830	24B830	24B830	24B830	24B830	24B830	24B830	24B830	1
14	HOUSING, inlet	197304	197304	197304	17C167	197304	17C167	17C167	197304	1
15	GUIDE, ball, inlet	198647	198647	198647	198647	198647	198647	198647	198647	1
16*	BALL, inlet; (pack of 3)	253030	253030	253030	253030	253030	253030	253030	253030	1
17	SHIM, inlet, ball guide (pack of 9)	244856	244856	244856	244856	244856	244856	244856	244856	3
18	SEAT, inlet	197344	197344	197344	197344	197344	197344	197344	197344	1
19*	PLUG, throat seal (pack of 10)	247395	247395	247395	247395	247395	247395	247395	247395	1
20†	CAP, filter, top			16M461				16M461	16M461	1
21	SPRING, compression			171941				171941	171941	1
22*†	O-RING, filter; thin, PTFE (10 pack)			244895				244895	244895	1
23	STRAINER, 60 mesh screen; (2 pack) see page 31 for more options			224459				224459	224459	1
24	SUPPORT, filter			186075				186075	186075	1
25*†	O-RING, filter; medium, PTFE (10 pack)			262484				262484	262484	1
26†	CAP, filter			16M462				16M462	16M462	1
27a*‡	O-RING; throat cartridge, PTFE, blue, thin (pack of 10)	244891	244891	244891	244891	244891	244891	244891	244891	1
27b*	O-RING, PTFE, foot valve and cylinder bottom, thin (10 pack)	244894	244894	244894	244894	244894	244894	244894	244894	4
30▲	TAG, warning	172479	172479	172479	172479	172479	172479	172479	172479	1
38	FITTING, nipple, outlet 1/2 in.			158491				158491	158491	1
39	PLUG, packless; 1/2 in.			24N518				24N518	24N518	1
40	VALVE, pressure dump			245143				245143	245143	1
41	FITTING, barbed, plated			116746				116746	116746	1
42	TUBE, nylon			116750				116750	116750	1
49	PLUG, pipe	101754	101754	198292	101754	101754	101754	198292	198292	1
59*†	O-RING, filter; thick, PTFE (10 pack)			262483				262483	262483	1

▲ Replacement safety labels, tags, and cards are available at no cost.

\* Parts included in repair kits.

‡ Blue o-ring for 220, 250, and 290 lowers.

† See page 32 to verify correct part numbers.

Part numbers listed are for bulk quantities. Individual quantities are included in repair kits. See **Repair Kits** starting on page 27.

# Repair Kits

## Repair Kits - Graco Formulated UHMWPE/Leather

Repair kits contain a set of four UHMWPE and three leather packings for the throat, and a set of three UHMWPE and two leather packings for the piston that are ideal for abrasive applications. Xtreme Seal packing sets are standard in Xtreme NXT Spray Packages and are used with models L\_\_\_ C1, L\_\_\_ C2, L\_\_\_ C5, L\_\_\_ C6 L\_\_\_ M, L1 \_\_\_ CL, L1 \_\_\_ CN, L\_\_\_ C8, and

some 5.9 in. bolt pattern models. Kits also include items 9, 12, 16, 19, 22, 25, 27, 32, and 59. See parts list for your lower model.

### Throat Packing (3) Detail

### Piston Packing (4) Detail

Lower Size	Full Repair Kit	Descriptions, Reference Numbers, and Quantity	
		Throat Seal Kit (3a-3e)	Piston Seal Kit (4a-4d)
		Replaces entire packing stack in throat (see Fig. 5)	Replaces entire packing stack in piston (see Fig 5.)
85cc	25D232	25D132	25D139
115cc	*	25D133	25D140
145cc	25D234	25D134	25D141
180cc	25D235	25D135	25D142
220cc	25D236	25D136	25D143
250cc	25D237	25D137	25D144
290cc	25D238	25D138	25D145

\* See 115cc Xtreme Repair Parts Manual, **Related Manuals**, page 2.

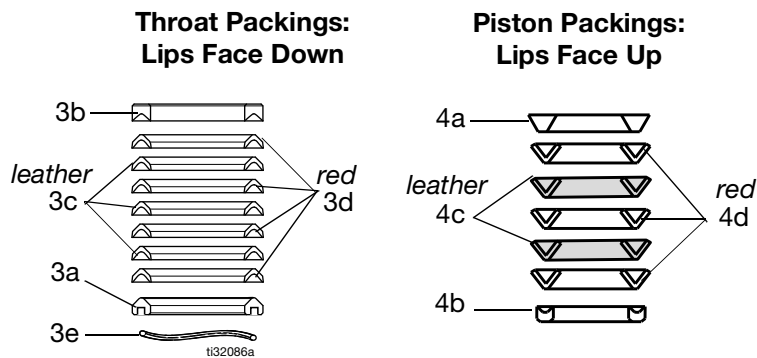

Lubricate packings; soak leather packings in oil for one hour before assembly.

FIG. 5: Repair Kits

## Repair Kits - PTFE

Repair kits contain a set of seven PTFE packings for the throat, and five PTFE packings for the piston that are ideal for chemical resistance and higher temperatures. Not ideal for abrasive applications. These kits are for models L\_\_\_ C3, L\_\_\_ C4, and some 5.9 in.bolt

pattern models. Kits also include items 9, 12, 16, 19, 22, 25, 27, 32, and 59. See parts list for your lower model.

### Throat Packing (3) Detail

### Piston Packing (4) Detail

Lower Size	Full Repair Kit	Descriptions, Reference Numbers, and Quantity	
		Throat Seal Kit (3)	Piston Seal Kit (4)
		Replaces entire packing stack in throat (see Fig. 6)	Replaces entire packing stack in piston (see Fig. 6)
36cc	25D239	25D146	25D156
48cc	25D240	25D147	25D157
58cc	25D241	25D148	25D158
85cc	25D242	25D149	25D159
115cc	*	25D150	25D160
145cc	25D244	25D151	25D161
180cc	25D245	25D152	25D162
220cc	25D246	25D153	25D163
250cc	25D247	25D154	25D164
290cc	25D248	25D155	25D165

\* See 115cc Xtreme Repair Parts Manual, **Related Manuals**, page 2.

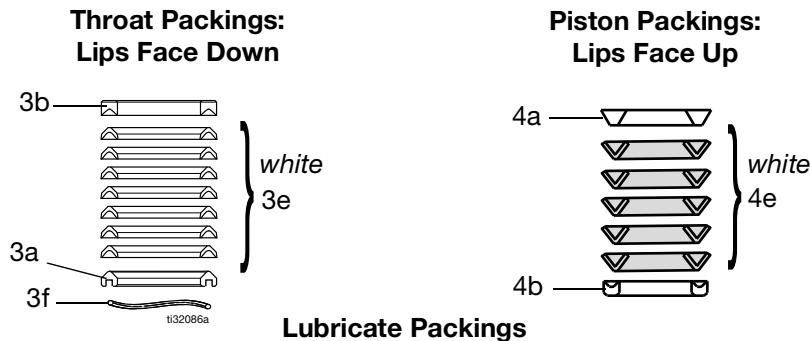

FIG. 6: Seals Repair Kits

## Repair Kits - Graco Formulated UHMWPE/PTFE

Repair kits contain a set of four UHMWPE and three PTFE packings for the throat, and three UHMWPE and two PTFE packings for the piston that are for chemical resistance and durability in applications below 140 °F (60 °C). UHMWPE and PTFE packing sets are standard in XP Proportioners and are used with L\_\_\_ C0, L\_\_\_ C7, and L\_\_\_ C9 models and some 5.9 in. bolt pattern

models. Kits also include items 9, 12, 16, 19, 22, 25, 27, 29, 32, 43, and 59. See parts list for your lower model.

**NOTE:** All L\_\_\_ C0 XP lowers built prior to April 2012 came with Tuff-Stack packing sets.

### Throat Packing (3) Detail

### Piston Packing (4) Detail

Lower Size	Full Repair Kit	Descriptions, Reference Numbers, and Quantity	
		Throat Seal Kit (3)	Piston Seal Kit (4)
		Replaces entire packing stack in throat (see Fig. 7)	Replaces entire packing stack in piston (see Fig. 7)
36cc	25D249	25D166	25D180
48cc	25D250	25D167	25D181
54cc	25D251	25D168	25D182
58cc	25D252	25D169	25D183
72cc	25D253	25D170	25D184
85cc	25D254	25D171	25D185
90cc	25D255	25D172	25D186
97cc	25D256	25D173	25D187
115cc	*	25D174	25D188
145cc	25D258	25D175	25D189
180cc	25D259	25D176	25D190
220cc	25D260	25D177	25D191
250cc	25D261	25D178	25D192
290cc	25D262	25D179	25D193

\* See 115cc Xtreme Repair Parts Manual, **Related Manuals**, page 2.

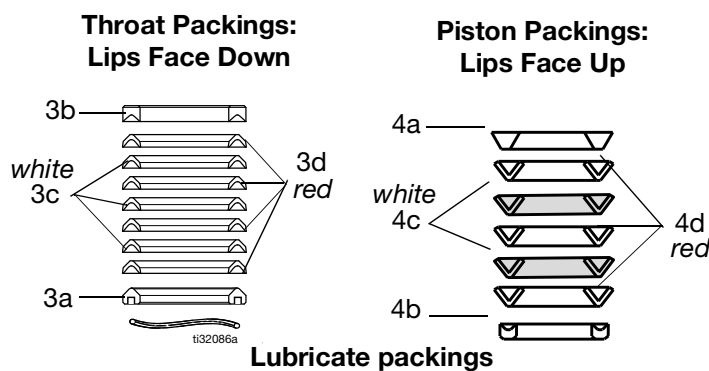

FIG. 7: Repair Kits

## Repair Kits - Graco Formulated PTFE/Leather

Repair kits contain a set of four PTFE and three leather packings for the throat, and a set of three PTFE and two leather packings for the piston that are ideal for abrasive applications. Xtreme Seal packing sets are standard in Xtreme NXT Spray Packages and are used with models L\_ \_ \_ and some 5.9 in. bolt pattern models. Kits also include items 9, 12, 16, 19, 22, 25, 27, 32, and 59. See parts list for your lower model.

**NOTE:** All L\_ \_ \_ C0 XP lowers built prior to April 2012 came with Tuff-Stack packing sets.

### Throat Packing (3) Detail

### Piston Packing (4) Detail

Lower Size	Full Repair Kit	Descriptions, Reference Numbers, and Quantity	
		Throat Seal Kit (3)	Piston Seal Kit (4)
		Replaces entire packing stack in throat (see FIG. 8)	Replaces entire packing stack in piston (see FIG. 8)
220cc	26D697	26D842	26D696

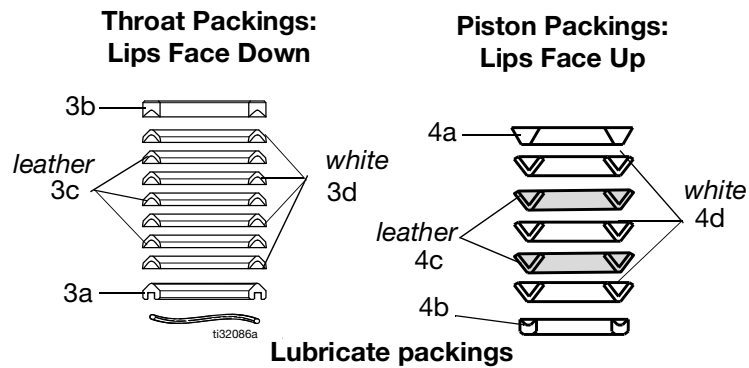

FIG. 8: Repair Kits

# Kits

## Inlet Ball Spring Kits

Use to improve change over rates in longer ball travel configurations. Order kit that corresponds with your lower model. See manual 406527.

**NOTE:** All XP Xtreme pumps include inlet springs.

Kit	Lower Models
245190	115cc*, 145cc, 180cc sizes
245191	220cc, 250cc, 290cc sizes

\* 115 cc Series H and newer.

## Fluid Drain Valve Repair Kit 245145

**NOTE:** Not for use with XP lowers.

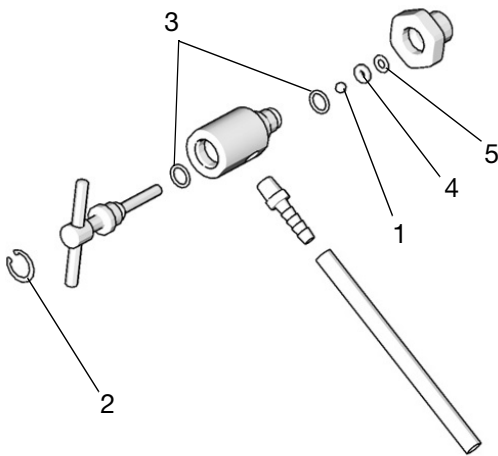

Ref.	Description	Qty.
1	BALL, carbide	1
2	RING, retaining	1
3	O-RING, PTFE	2
4	SEAT, valve	1
5	GASKET	1

## Replacement Strainers (Ref. 23)

For models with built-in filters, Series A and B pumps used 3 in. (76.2 mm) strainers 236495 in pump sizes 36-115cc. All Xtreme pumps now use 5.65 in. (143.5 mm) strainers listed below. See page 32 for conversion kit

Lower Size	2 Pack			25 Pack		
	30 mesh	60 mesh	100 mesh	30 mesh	60 mesh	100 mesh
All	224458	224459	224468	238436	238438	238440

**NOTE:** Standard Xtreme filter pumps come with 60 mesh XP Xtreme filter pumps comes with 30 mesh.

## Ceramic Balls

Xtreme Lower	Ceramic Piston Ball	Ceramic Inlet Ball
115*	111453	119264
145	111453	119264
180	111453	119264
220	118602	131271
290	117321	131271

\*115 cc Series H and newer.

### Filter Cap Repair Kit, 24F975

Use to improve sealing of Series A filters. See manual 406882 for more information.

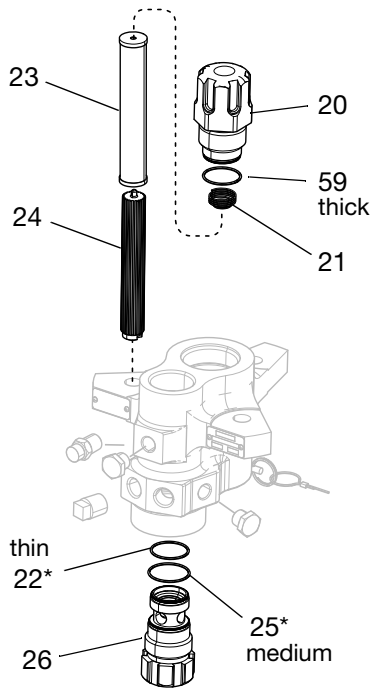

Ref.	Description	Qty.
20	CAP, filter, top; all pumps	1
21	SPRING	1
22	O-RING; white, thin	1
23a	STRAINER, 30 mesh, 5.65 in. (143.5 mm)	1
23b	STRAINER, 60 mesh, 5.65 in. (143.5 mm)	1
24	SUPPORT, filter	1
25	O-RING; white, medium	1
26	CAP, filter	1
59	O-RING, PTFE; white, thick	1

### Series Change

The original filter cap seals were changed in 2010 for improved sealing. The o-rings are not interchangeable between different series filter caps.

The pump series for all Xtreme and XP lowers are identified by the circular grooves on the top filter cap (20).

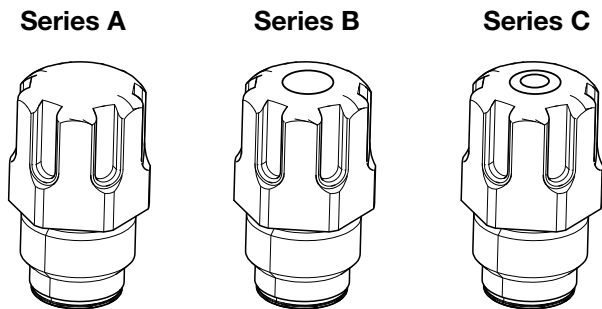

Series	Change Description
<b>B</b>	Uses thick, medium, and thin cross-section o-rings.
	Filter caps changed to accept new o-rings
<b>C</b>	Uses 5.65 in. (143.5 mm) strainers and supports all sizes.

Benefits of the new filter cap repair kit include:

- Compatible with all pump sizes
- Improves sealing
- Ensures filters are installed correctly



# Dimensions

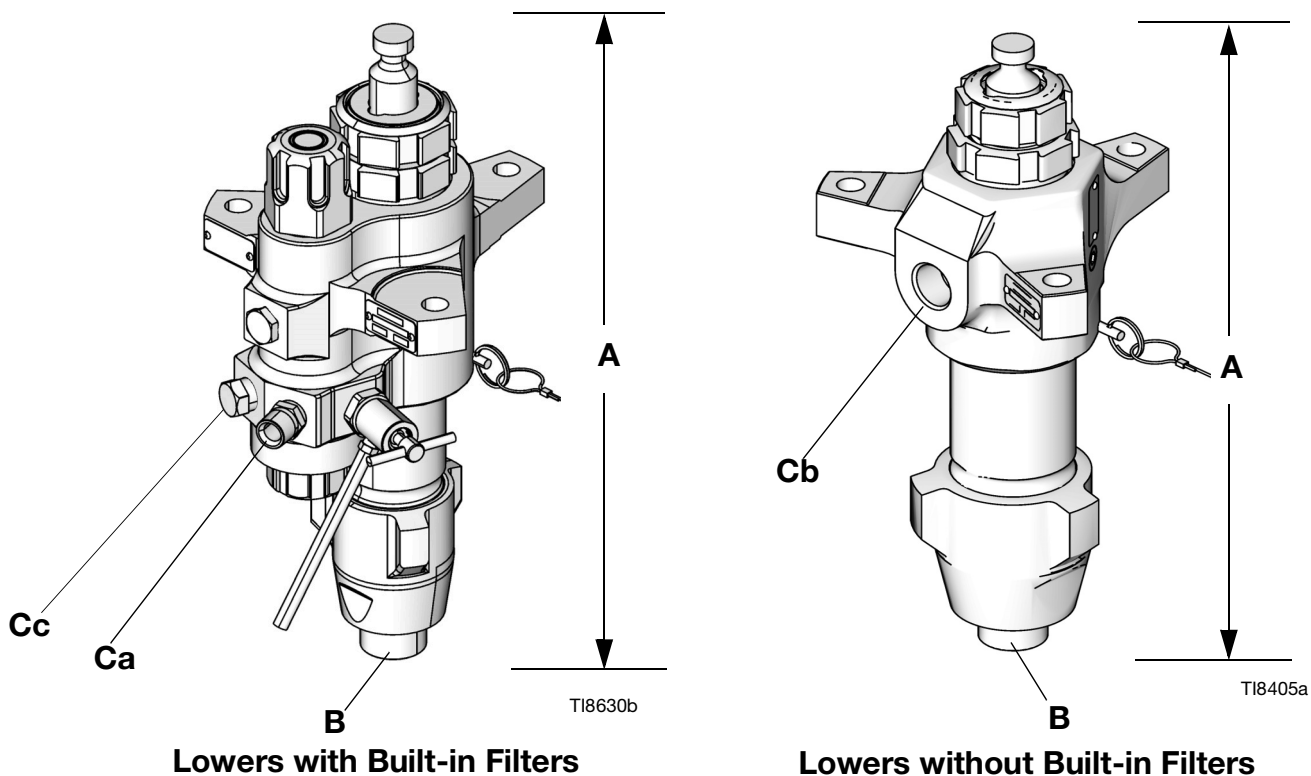

## Lower Dimensions

Lower	A (Height) in. (mm)	B (Inlet) in. npt(m)	Ca (Outlet) in. npt(m)	Cb (Outlet) in. npt(f)	Cc (Outlet) in. npt(f)	Weight lbs (kg)	
						Without Filter	With Filter
36cc	17.0 (432)	1-1/4	1/2	NA	1/2	NA	36 (16.3)
48cc	17.0 (432)	1-1/4	1/2	NA	1/2	NA	36 (16.3)
54cc	17.0 (432)	1-1/4	1/2	NA	1/2	NA	36 (16.3)
58cc	17.0 (432)	1-1/4	1/2	NA	1/2	NA	36 (16.3)
72cc	17.0 (432)	1-1/4	1/2	NA	1/2	NA	36 (16.3)
85cc	17.0 (432)	1-1/4	1/2	1/2	1/2	28 (12.7)	36 (16.3)
90cc	17.0 (432)	1-1/4	1/2	NA	1/2	NA	36 (16.3)
97cc	17.0 (432)	1-1/4	1/2	NA	1/2	NA	36 (16.3)
115cc	17.0 (432)	1-1/4	1/2	1/2	1/2	28 (12.7)	36 (16.3)
145cc★	17.0 (432)	1-1/4★	1/2	3/4	1/2	38 (17.3)	48 (21.8)
14Acc	17.0 (432)	1-1/4	1/2	3/4	1/2	38 (17.3)	48 (21.8)
180cc★	17.0 (432)	1-1/4★	1/2	3/4	1/2	38 (17.3)	48 (21.8)
18Acc	17.0 (432)	1-1/4	1/2	3/4	1/2	38 (17.3)	48 (21.8)
220cc	17.0 (432)	1-1/4	1/2	1	1/2	42 (19.1)	52 (23.6)
22Acc	17.0 (432)	1-1/4	1/2	1	1/2	42 (19.1)	52 (23.6)
250cc	17.0 (432)	1-1/4	1/2	1	1/2	42 (19.1)	52 (23.6)
290cc	17.0 (432)	1-1/4	1/2	1	1/2	43 (19.5)	53 (24.1)
29Acc	17.0 (432)	1-1/4	1/2	1	1/2	43 (19.5)	53 (24.1)

★ L145CL/N, L180CL/N e-Xtreme Lowers have a 1 in. npt (male) inlet.

# Outlet Housing Mounting Hole Layout

## 5.9 in. (150 mm) Outlet Housing (example) Shown

Applies to 36, 48, 54, 58, 72, 85, 90, 97, 115, 14A, 18A, 22A, 22X, and 29Acc Lowers

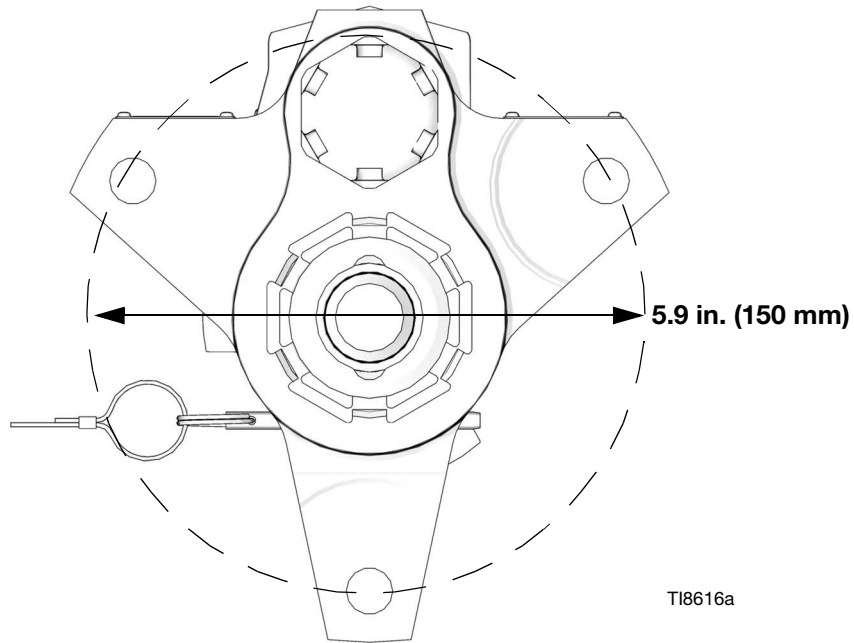

## 8.0 in. (203 mm) Outlet Housing (example) Shown

Applies to 145, 180, 220, 250, and 290cc Lowers

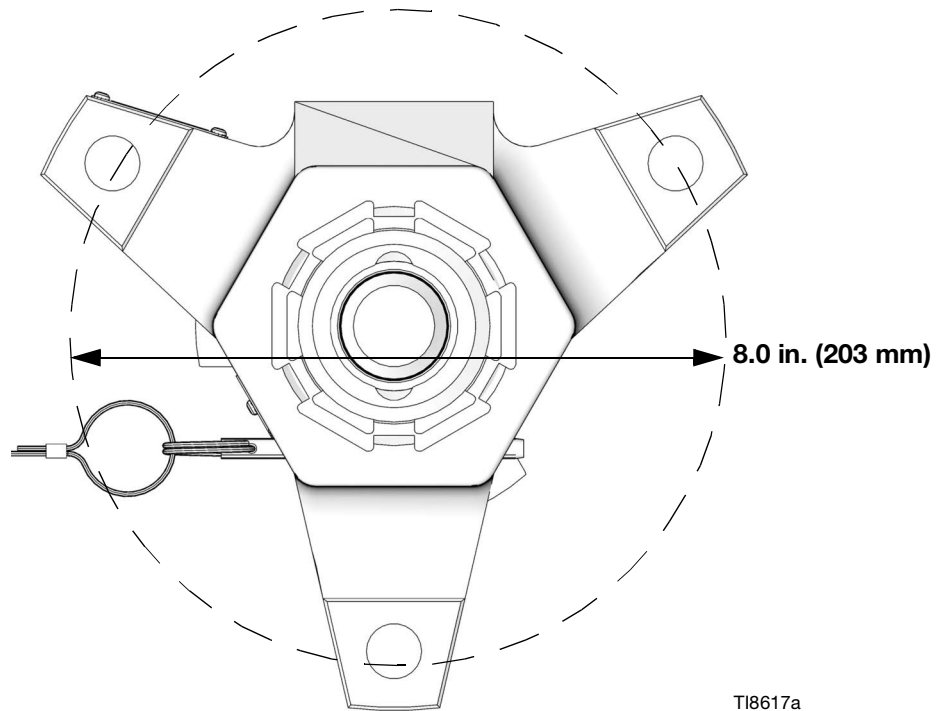

# Technical Specifications

<b>Xtreme Lowers</b>		
	<b>US</b>	<b>Metric</b>
Maximum operating temperature★	180° F	82° C
Wetted Parts	Carbon Steel; Alloy Steel; 304, 440 and 17-4 PH Grades of Stainless Steel; Zinc and Nickel Plating; Ductile Iron; Tungsten Carbide; PTFE; Leather	
Stroke length	4.75 in.	12.06 cm
<b>Maximum fluid working pressure</b>		
L036C0	7250 psi	50 MPa, 500 bar
L046C0	7250 psi	50 MPa, 500 bar
L054C0	7250 psi	50 MPa, 500 bar
L058C0	7250 psi	50 MPa, 500 bar
L072C0	7250 psi	50 MPa, 500 bar
L085C0, L085C1, L085C2, L085C3, L085C4	7250 psi	50 MPa, 500 bar
L090C0	7250 psi	50 MPa, 500 bar
L097C0	7250 psi	50 MPa, 500 bar
L115C0, L115C1, L115C2, L115C3, L115C4	7250 psi	50 MPa, 500 bar
L115C5, L115C6	7250 psi*	50 MPa, 500 bar*
L145C5, L145C6	7250 psi*	50 MPa, 500 bar*
L145M2, L145C0, L145C1, L145C2, L145C3, L145C4, L14AC1, L145CP, L145CR	7400 psi	51 MPa, 511 bar
L145C8, L145CL, L145CN, L180CL, L180CN	6000 psi*	41 MPa, 410 bar*
L180C0, L180C1, L180C2, L180C3, L180C4, L180C7, L180C9, L18AC1, L180M2	7400 psi	51 MPa, 511 bar
L220M2, L220C0, L220C1, L220C2, L220C3, L220C4, L220C7, L220C9, L22AC1, LL220CT	6000 psi	41 MPa, 414 bar
L250C0, L250C1, L250C2, L250C3, L250C4	5600 psi	39 MPa, 386 bar
L250C8, 25A710	5600 psi	39 MPa, 386 bar
L290M2, L290C0, L290C1, L290C2, L290C3, L290C4, L290C7, L29AC1, 24N942	5600 psi	39 MPa, 386 bar
L22HC1, L22HC2, L25HC1, L25HC2, L29HC1, L29HC2, L22XC0	7250 psi	50 MPa, 500 bar
<b>Nominal displacement per cycle</b>		
L036C0		36cc
L046C0		46cc
L054C0		54cc
L058C0		58cc
L072C0		72cc
L085C0, L085C1, L085C2, L085C3, L085C4		85cc
L090C0		90cc
L097C0		97cc
L115C0, L115C1, L115C2, L115C3, L115C4, L115C5, L115C6		115cc

<b>Xtreme Lowers</b>		
	<b>US</b>	<b>Metric</b>
L145C0, L145C1, L145C2, L145C3, L145C4, L145C8, L14AC1, L145M2, L145CP, L145CR, L145CL, L145CN, L115C5, L115C6		145cc
L180C0, L180C1, L180C2, L180C3, L180C4, L180C7, L180C9, L18AC1, L180M2, L180CL, L180CN		185cc
L220C0, L220C1, L220C2, L220C3, L220C4, L220C7, L220C9, L22AC1, L22HC1, L22HC2, L22XC0, L220M2, L220CT		220cc
L250C0, L250C1, L250C2, L250C3, L250C4, L250C8, L25HC1, L25HC2, 25A710		250cc
L290C0, L290C1, L290C2, L290C3, L290C4, L290C7, L29AC1, 24N942, L29HC1, L29HC2, L290M2		290cc
<b>Effective Area</b>		
L036C0	0.2325 in.	1.500 cm
L046C0	0.3100 in.	2.000 cm
L054C0	0.349 in.	2.250 cm
L058C0	0.3715 in.	2.397 cm
L072C0	0.465 in.	3.000 cm
L085C0, L085C1, L085C2, L085C3, L085C4	0.5542 in.	3.575 cm
L090C0	0.581 in.	3.750 cm
L097C0	0.620 in.	4.000 cm
L115C0, L115C1, L115C2, L115C3, L115C4, L115C5, L115C6	0.7430 in.	4.793 cm
L145M2, L145C0, L145C1, L145C2, L145C3, L145C4, L145C8, L14AC1, L145CP, L145CR, L145CL, L145CN, L145C5, L145C6	0.9300 in.	6.000 cm
L180C0, L180C1, L180C2, L180C3, L180C4, L180C7, L180C9, L18AC1, L180M2, L180CL, L180CN	1.1624 in.	7.500 cm
L220C0, L220C1, L220C2, L220C3, L220C4, L220C7, L220C9, L22AC1, L22HC1, L22HC2, L22XC0, L220M2, L220CT	1.395 in.	9.000 cm
L250C0, L250C1, L250C2, L250C3, L250C4, L250C8, L25HC1, L25HC2, 25A710	1.620 in.	10.452 cm
L290C0, L290C1, L290C2, L290C3, L290C4, L290C7, L29AC1, 24N942, L29HC1, L29HC2, L290M2	1.860 in.	12.000 cm
<b>Effective Area</b>		
<p>★ Maximum operating temperature of 25A710 is 390° F (200° C).                      ※ Due to installed over pressure rupture discs.                      All trademarks or registered trademarks are the property of their respective owners.</p>		

# California Proposition 65

## CALIFORNIA RESIDENTS

 **WARNING:** Cancer and reproductive harm – [www.P65warnings.ca.gov](http://www.P65warnings.ca.gov).

# Graco Standard Warranty

Graco warrants all equipment referenced in this document which is manufactured by Graco and bearing its name to be free from defects in material and workmanship on the date of sale to the original purchaser for use. With the exception of any special, extended, or limited warranty published by Graco, Graco will, for a period of twelve months from the date of sale, repair or replace any part of the equipment determined by Graco to be defective. This warranty applies only when the equipment is installed, operated and maintained in accordance with Graco's written recommendations.

This warranty does not cover, and Graco shall not be liable for general wear and tear, or any malfunction, damage or wear caused by faulty installation, misapplication, abrasion, corrosion, inadequate or improper maintenance, negligence, accident, tampering, or substitution of non-Graco component parts. Nor shall Graco be liable for malfunction, damage or wear caused by the incompatibility of Graco equipment with structures, accessories, equipment or materials not supplied by Graco, or the improper design, manufacture, installation, operation or maintenance of structures, accessories, equipment or materials not supplied by Graco.

This warranty is conditioned upon the prepaid return of the equipment claimed to be defective to an authorized Graco distributor for verification of the claimed defect. If the claimed defect is verified, Graco will repair or replace free of charge any defective parts. The equipment will be returned to the original purchaser transportation prepaid. If inspection of the equipment does not disclose any defect in material or workmanship, repairs will be made at a reasonable charge, which charges may include the costs of parts, labor, and transportation.

**THIS WARRANTY IS EXCLUSIVE, AND IS IN LIEU OF ANY OTHER WARRANTIES, EXPRESS OR IMPLIED, INCLUDING BUT NOT LIMITED TO WARRANTY OF MERCHANTABILITY OR WARRANTY OF FITNESS FOR A PARTICULAR PURPOSE.**

Graco's sole obligation and buyer's sole remedy for any breach of warranty shall be as set forth above. The buyer agrees that no other remedy (including, but not limited to, incidental or consequential damages for lost profits, lost sales, injury to person or property, or any other incidental or consequential loss) shall be available. Any action for breach of warranty must be brought within two (2) years of the date of sale.

**GRACO MAKES NO WARRANTY, AND DISCLAIMS ALL IMPLIED WARRANTIES OF MERCHANTABILITY AND FITNESS FOR A PARTICULAR PURPOSE, IN CONNECTION WITH ACCESSORIES, EQUIPMENT, MATERIALS OR COMPONENTS SOLD BUT NOT MANUFACTURED BY GRACO.** These items sold, but not manufactured by Graco (such as electric motors, switches, hose, etc.), are subject to the warranty, if any, of their manufacturer. Graco will provide purchaser with reasonable assistance in making any claim for breach of these warranties.

In no event will Graco be liable for indirect, incidental, special or consequential damages resulting from Graco supplying equipment hereunder, or the furnishing, performance, or use of any products or other goods sold hereto, whether due to a breach of contract, breach of warranty, the negligence of Graco, or otherwise.

## **FOR GRACO CANADA CUSTOMERS**

The Parties acknowledge that they have required that the present document, as well as all documents, notices and legal proceedings entered into, given or instituted pursuant hereto or relating directly or indirectly hereto, be drawn up in English. Les parties reconnaissent avoir convenu que la rédaction du présente document sera en Anglais, ainsi que tous documents, avis et procédures judiciaires exécutés, donnés ou intentés, à la suite de ou en rapport, directement ou indirectement, avec les procédures concernées.

# Graco Information

For the latest information about Graco products, visit [www.graco.com](http://www.graco.com).

For patent information, see [www.graco.com/patents](http://www.graco.com/patents).

**TO PLACE AN ORDER, contact your Graco distributor or call to identify the nearest distributor.  
Phone: 612-623-6921 or Toll Free: 1-800-328-0211 Fax: 612-378-3505**

*All written and visual data contained in this document reflects the latest product information available at the time of publication.  
Graco reserves the right to make changes at any time without notice.*

Original instructions. This manual contains English. MM

**Graco Headquarters:** Minneapolis

**International Offices:** Belgium, China, Japan, Korea

**GRACO INC. AND SUBSIDIARIES • P.O. BOX 1441 • MINNEAPOLIS MN 55440-1441 • USA  
Copyright 2021, Graco Inc. All Graco manufacturing locations are registered to ISO 9001.**

[www.graco.com](http://www.graco.com)  
Revision ZAR, May 2022