

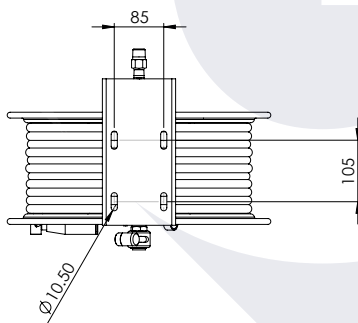

APACHE UNIVERSAL 2.0

The Jetwave® Apache™ Universal 2.0 heavy duty pedestal style hose reel is a hand crank industrial reel designed to hold up to 50m (3/8") hose increasing user utility and safety to complete your high pressure cleaner/water jetter package.

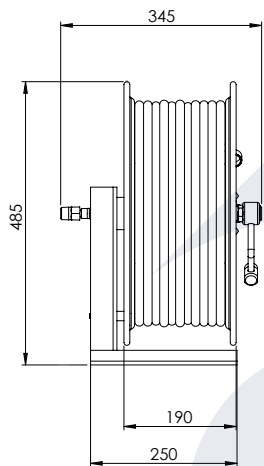

NEW

STANDOUT FEATURES



Strong one piece welded drum design.



Durable high gloss powder coated finish.



Extra heavy duty 5-point locking pin.



Stainless steel 5075 psi swivel with Parker Viton O-Rings.



3/8" MF on inlet and outlet.



Foldable / handle.

- Optional hose guide kit

- Protects hose when being withdrawn / reloaded at any angle.

The manufacturer reserves the right to modify design features and technical facts without notice; due to our principals of continuous improvement.

V2.0 12/2020

Model / Product Code	Max Hose Capacity (m)	Working Pressure psi bar	Flow Rate l/pm	Max Temp °C	Type	Outlet (Swivel Side) to hose	Inlet lead hose connection point	Boxed Dimensions (mm)	Approx Weight (kg)	Number per Pallet type: pieces
DHRP50150	50 of 3/8"	5075 350	Up to 40	90	Hand Crank	3/8" F	3/8" M	470(l) x 340(w) x 490(h)	15	AS: 18