

Includes models

IM012E-01
IM012E-02



macnaught

IM012E (ELECTRONIC)

POSITIVE DISPLACEMENT FLOWMETER

INSTRUCTION MANUAL



To the Owner

PLEASE READ THIS INFORMATION CAREFULLY BEFORE USE.

Read and retain this instruction manual to assist you in the operation and maintenance of this product.

If you have any problems with the meter, refer to the maintenance and trouble shooting sections of this manual.

This manual contains connection and operating instructions for meters with Liquid Crystal displays (LCD).

If you need further assistance, please contact your local representative or distributor for advice.

This Flow Meter has incorporated the oval rotor principal into its design. This has proven to be a reliable and highly accurate method of measuring flow.

Exceptional repeatability and high accuracy over a wide range of fluid viscosities and flow rates are features of the oval rotor design. With a low pressure drop and high pressure rating oval rotor flow meters are suitable for both gravity and pump (in line)

Important Information



WARNING

Before use, confirm the fluid to be used is compatible with the meter. Refer to Industry fluid compatibility charts or consult your local representative for advice.

Operating Principle

When fluid passes through the meter the rotors turn, as shown below. The magnets which are located in the rotors will pass across the PCB sensors.

A signal is generated which is then sent by the PCB to the relevant LCD, or receiving instrument as a Pulse Output.



Operational Overview

1. During normal operation the 6 Figure LCD display will appear as per the example diagram below.



2. Pressing the blue 'Mode' button will enable the operator to toggle between the following two Display options.

- Batch
- Total

3. The 'Batch' total can be reset by pressing the red 'Reset' button.

Please note:

This function resets the 'Batch' only. The 'Total' displayed is unable to be reset.

4. A 'Sleep' mode has been incorporated in the meter to prolong battery life. The unit will activate sleep mode after 30 secs without use.

Programming Instructions



Note

Any changes made during the programming phase will automatically be 'Saved' when the unit is returned to the operation mode.

Accessing 'Programming' Menu

To enter in the programming 'Menu', press the reset button for 5 secs.

Once in the programming menu the operator will be able to access (and adjust) 3 programming selections.

- 1- Setting Decimal Place
- 2- Display Units of measurement
- 3 - Calibration Mode

Setting the decimal place.

1. The unit will display the mode and the number of Decimal Places currently set.
E.g. 'dEC .22'

2. Pressing the blue 'Mode' button will cycle through options available

- dEC .1 = 1 Decimal Place
- dEC .22 = 2 Decimal Places
- dEC .333 = 3 Decimal Places

3. To move to the next section (Unit) press the red 'Reset' button

Setting the Units for both Batch & Total.

1. The LCD will now display 'UNIT'.
See 'Operational Overview'.
2. Pressing the blue 'Mode' button will cycle through the options of units that can be displayed for Batch.

- L
- GAL
- Qt
- Pt
- Oz
- dL

3. Next press the red 'Reset' button to move onto setting the 'Total' units. The available unit options are as shown above.
4. Once the required 'Units' have been selected move to the next section (Calibration) by pressing the Red 'Reset' button.

Calibration.

The calibration mode enables, in the case the operator suspects the accuracy of the meter is in question, the operator to dispense a known volume of fluid through the meter (Test Volume)

This Test Volume is compared to the volume measured by the meter (Measured Volume). The meter will perform an 'Auto Calibration' if applicable.

1. The unit will display 'CALIBRATE' in the lower left hand corner, and a number on the main display.

The following options can be scrolled through by pressing the blue Mode button

- 2
- 4
- 8
- 20
- 100
- 250

This number represents the 'Test Volume' to be dispensed through the meter during Calibration.

Programming Instructions

2. On selecting the 'Test Volume' press the blue *Mode* button for 3 secs.
The meter will display 'PURGE' and 'CALIBRATE' will also start to flash.
3. Purge the system of air by running fluid through the system.
4. Once purged of air the calibration process can be started by pressing the blue *Mode* button.
The unit will display **RUN** and the 'Test Volume'.
E.g. **RUN 100**
5. Run the Test Volume through the meter until stipulated volume has been reached (e.g. 100).
6. Once this volume has been reached press the blue *Mode* button to stop the test.
The unit will now compare the 'Measured Volume' to the 'Test Volume' and perform an 'Auto Calibration' if the difference between the two volumes are within $\pm 8\%$ of each other.

Note:

If the difference between the two volumes is greater than $\pm 8\%$ of each other, the unit will display one of the following messages..

- ERROR LOW
- ERROR HIGH

if these messages are displayed please contact your Macnaught agent for advice.

Returning to 'Operation' Mode

At any stage the unit can be returned to the 'Operation' mode by pressing the red 'Reset' button for approx. 3 secs.
Any program changes will automatically be saved.

Maintenance Procedures.

Disassembly

Ensure that the fluid supply to the meter is disconnected, and the line pressure is released before disassembly, with the exception for repair or maintenance to the LCD or PCB where it is not necessary to isolate the meter from flow. Refer to the exploded parts diagram on subsequent pages for item numbers.

1. Pull off protective boot (item 1) and unscrew the four retaining screws (item 2) next remove the Electronic Module (item 3)
2. Check for evidence of moisture into the electronic housing. If there is evidence of this, check the condition of the O-Ring (item 4)
3. To access the Rotor assembly, remove the 8 Meter Cap screws (item 9)

4. Remove the rotors (item 6) and inspect the condition of each.
Also investigate if there is the presence of any foreign material in the meter body, that may inhibit the rotors performance

Reassembly

1. Please note, the design of the rotor and shaft assembly ensures that the rotors can only be re-installed with the correct orientation. (i.e. with the magnets being in close proximity to the Electronic module).
When replacing the rotors the top face of the rotors should be flush with the sealing face of the meter body. If they sit higher than the sealing face remove, turn over and replace.
2. Replace the rotors (Item 6) onto the shafts at 90 degrees to each other (as per diagram below) and check their operation by turning either of the rotors.
If the rotors are not 'in mesh' correctly or do not move freely, remove one of the rotors and replace correctly at 90 degrees to the other rotor.

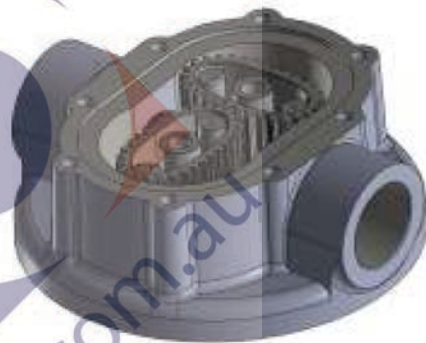

3. Check the Rotors (item 6) rotate freely.
4. Replace the O-Ring (item 7) into the groove of the Meter Cap (item 8).
5. Replace the Meter Cap onto Meter Body (item 5)
Tighten Meter Cap screws (item 9) in a diagonal sequence
E.g. 1, 5, 3, 7, 4, 8, 6, 2
6. Place the O-Ring (item 4) into the Electronic Module (item 3) and mount the Electronic module onto to the Meter Body
7. Replace and tighten the Retaining Screws (item 2) in diagonal sequence.
8. Align and push on the protective boot (item 1) onto the electronic module (item 3).
9. Before returning to service test the meter by turning the Rotors with your finger. Or applying a very low air pressure (no more than a good breath) to the meter

Maintenance Procedures

Changing the Battery.

A 'Low Battery' warning will be displayed on the LCD screen when there is 5% power left. The warning will remain active until the battery is replaced.

1. See 'Disassembly' procedure.
Follow step 1 to isolate the Electronic module.
2. See 'Photograph' below.
Remove the PCB from clear plastic housing by unscrewing the 3 retaining screws.
3. The battery can now be removed by placing a screw driver into the slot (*slot indicated by arrow*) on the PCB and easing the battery free from its compartment.
4. Replace with a new CR2450 Lithium battery.

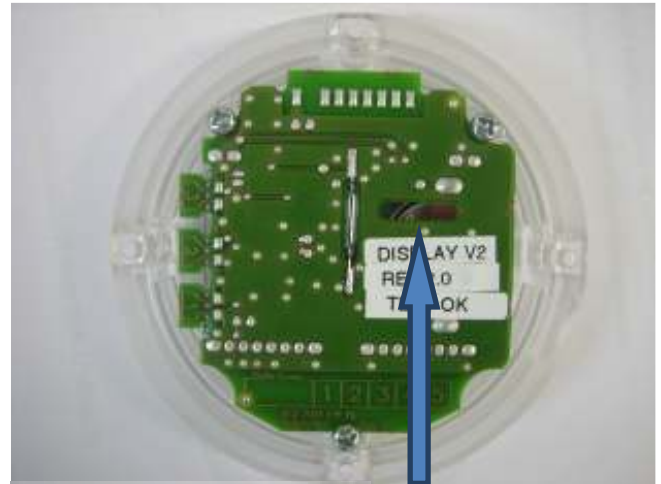

Battery Slot

Reed Switch

Please Note: Not dependant on Polarity

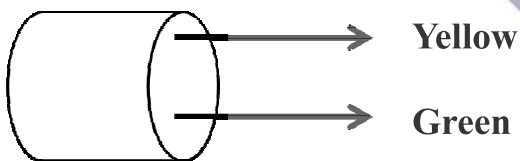

Exploded Diagram

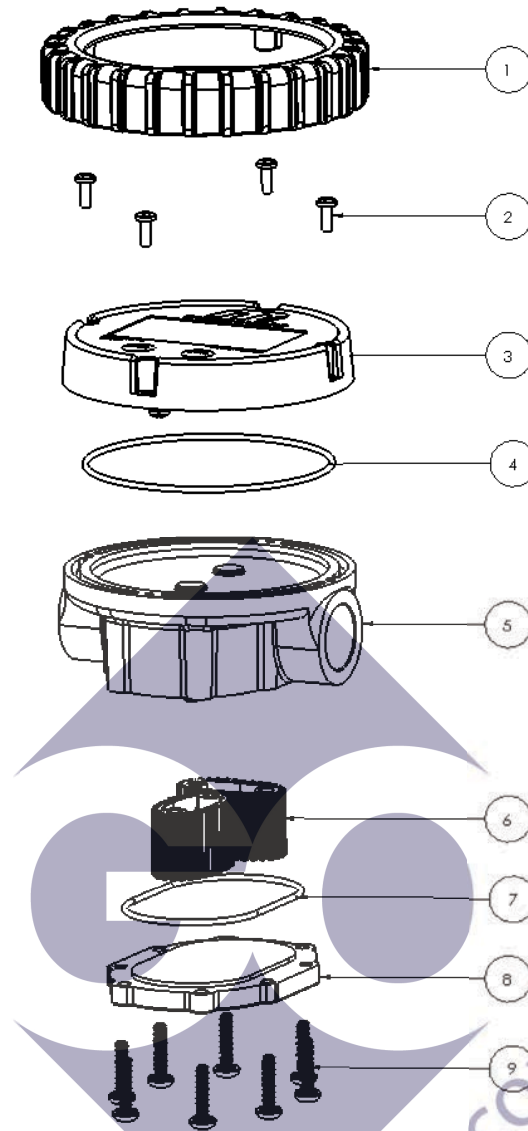

Spare part kits

| Order for replacement | | | |
|-----------------------|--------|---------------|----------------------|
| Item no | No off | Part or Set | Description |
| 1 | 1 | IM215s | Protective boot |
| 2 | 7 | DKIT-IM012-MC | Screw M3 x 8 Pan Hd |
| 3 | 1 | | Electronic module |
| 4 | 1 | | O'ring (BS040) |
| 5 | 1 | | n/a |
| 6 | 2 | MKIT-IM012-01 | Rotor |
| 7 | 1 | | O'ring (BS035) |
| 8 | 1 | n/a | Cover plate |
| 9 | 8 | n/a | Screw M4 x 16 Pan Hd |

Meter Dimensions



Notes



Troubleshooting Guide

| Problem | Cause | Remedy |
|-----------------------------------|--|--|
| Fluid will not flow through meter | a) Foreign matter blocking rotors b) Damaged rotors c) Meter connections over tightened d) Fluid is too viscous | a) Dismantle meter, clean rotors b) Replacement rotor assembly required. c) Re-adjust connections d) See specifications for maximum viscosity |
| Reduced flow through meter | a) Partially blocked b) Fluid is too viscous | a) Check and clean meter. b) See specifications for maximum viscosity |
| Meter reading inaccurate | a) Fluid flow rate is too high or too low b) Air in fluid. c) Excess wear. | a) See specifications for minimum and maximum flow rates b) Bleed air from system c) Check meter body and rotors. (see instructions) |
| Meter not giving a pulse signal | a) Faulty hall effect sensor b) Faulty reed switch c) Magnets failed | a) Replace PCB Board b) Replace PCB Board c) Replacement rotor assembly required |
| LCD register not working | a) Battery flat b) Faulty LC Display | a) Replace battery b) Replace PCB module |

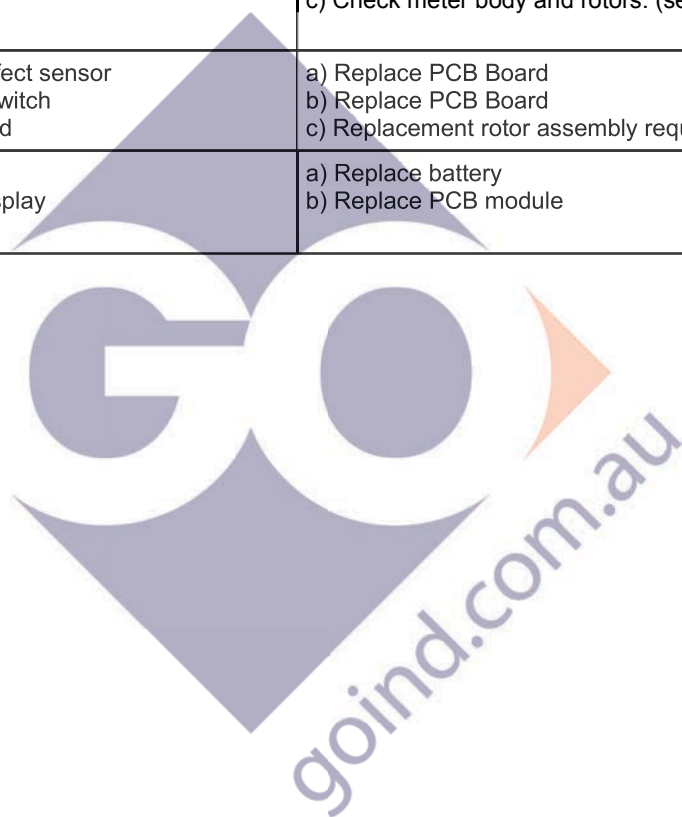

WEEE Directive - Waste Electrical and Electronic Equipment



The WEEE Directive requires the recycling of waste electrical and electronic equipment in the European Union.

Whilst the WEEE Directive does not apply to some of Macnaught's products, we support its policy and ask you to be aware of how to dispose of this product.

The crossed out wheeled bin symbol illustrated and found on our products signifies that this product should not be disposed of in general waste or landfill.

Please contact your local dealer national distributor or Macnaught Technical Services for information on product disposal.

Product Specifications

| | |
|---------------------------|---|
| Accuracy | + / - 0.5% of Reading |
| Type | Oval Gear |
| Flow rate | 1 Ltr -30 Ltr (0.26 - 8 US Gal) per minute |
| Maximum Pressure | 6900kPa / 1000psi / 69 Bar |
| Suitable for use with : | Engine Oil, Diesel Oil, Automatic Transmission Fluid (Maximum Viscosity SAE140), Ethelene Glycol Based Anti-Freeze / Anti-Boil mixture (Max 50% w ater) |
| Wetted Materials | Acetal, Aluminium, Steel, Nitrile Rubber |
| Connections | 1/2" BSPT or 1/2" NPT |
| Maximum Temperature | 55 deg C (131 deg F) |
| Minimum Temperature | -14 deg C (6.8 deg F) |
| Maximum Viscosity | 1000cP (Centipoise) |
| Re-settable 'Batch' Total | 99999.9 |
| Non-Resettable Total | 999999 |

* When tested with lubrication oil @ 25°C. Allowances should be made for changes to these parameters.



Note:

This product should be disposed of according to all applicable local and national government environment regulations and guidelines.



For Warranty Terms and Conditions see macnaught.com.au
 For a list of Australian Service Centres see macnaught.com.au