

Includes models

HG55-01

HG55-02

HG 55 OIL CONTROL GUN WITH ELECTRONIC METER

INSTRUCTION MANUAL



INTRODUCTION

Thank you for purchasing a HG55 Electronic oil control gun. Macnaught oil control guns have been designed to accurately dispense, measure and control oil flow. The control guns are suitable with engine oil, gear oil, automatic transmission fluid, anti-freeze/anti-boil and compatible fluids.

Please read and retain this instruction manual to assist you in the operation and maintenance of this quality product.

Note: Batteries are not pre-fitted and are included separately inside the box. Please refer to "Battery Replacement" on page 3 for correct procedure.

GENERAL INFORMATION

This manual assists you in operating and maintaining your new oil control gun. The information contained will help you ensure many years of dependable performance and trouble free operation.

Please take a few moments to read through this manual before installing and operating your new oil control gun. If you experience problems with this product, refer to the trouble shooting sections of this manual. If you require further assistance please contact your local Macnaught distributor or authorised Macnaught service centre.

IMPORTANT INFORMATION



READ THIS INFORMATION CAREFULLY BEFORE USE.

Your safety is important to us. Please read and follow all safety instructions listed inside.

Some of these instructions alert you to the potential for personal injury. "Cautions" listed throughout this manual advise of potential practices or procedures which may cause damage to your equipment.

Ensure all operators have access to adequate instructions about safe operating and maintenance procedures.



WARNING

This oil control gun should not be used for in-line installations or used with a manual a shut off nozzle.

The Safe operating pressure of this nozzle is 500 PSI

The line pressure between the pump and the dispensing handle trigger valve must not exceed 1500 PSI (103 BAR). Please ensure an adequate pressure relief valve is installed for operator safety.

The auto non drip nozzle **MUST** not be modified



CAUTION

Do not hit the oil control gun if it fails to operate. Refer to "trouble shooting guide" or return the unit to your nearest authorised service centre.



Never point the nozzle at yourself or anyone else.

Never exceed the pressure rating of any component installed in the System.

Before each use check all hoses for signs of wear, leaks or loose fittings. Tighten all fluid connections regularly and replace weak or damaged hoses.

Before attempting any repairs or maintenance of this product firstly disconnect the air supply from the oil pump, then release the oil line pressure by pressing the lever on your oil control gun.

ASSEMBLY

Use Teflon tape (or suitable thread sealant) when connecting the oil control gun to an oil hose.

Outlet Nozzle.

The outlet nozzle can be fitted either "inline" (forward) or on the outlet port "pistol style" located under the gun.

The long outlet tube should be used for the "inline" option.

The short adaptor should be used (instead of the long outlet tube) when using the "pistol style" option.

Note: Use the threaded Plug supplied to seal the outlet port not in use.

HANDLE OPERATION

To latch the handle, press the lever, push the button and then release lever.

METER INTRODUCTION

Operating mode description

Sleep Mode: To minimise battery consumption the meter will revert to sleep mode if left idle for more than 2 minutes, and will automatically "power up" if the RESET, button is pressed or there is flow through the meter.

The Reset button can be used in two ways:

Press – Press and release the button.

Double click – Press and release the button twice quickly.

TOTALIZERS

There are three totalizers built in to your meter:

- 1) **Reset-able batch total:** Displays the current volume dispensed. To reset batch total press the reset button.
- 2) **Non reset-able accumulative total** is located below the batch total and displays the total volume the meter has dispensed.
- 3) **Reset-able accumulative total** is hidden from view and is used to track daily, weekly, or monthly usage.

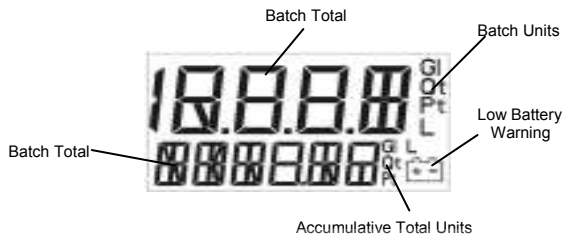

TO VIEW OR RESET ACCUMULATIVE TOTAL:

- 1) Double click the Reset button (the display will enter the reset-able total area.
- 2) To reset the reset-able total, press and release the Reset button.
- 3) The display will return to manual mode after 5 seconds.

How to change the Units setting:

- 1) Press and hold down the Reset button for five seconds. (The unit segment will appear)
- 2) Press the Reset button to cycle through the unit options.
- 3) Stop at the required setting.

Batch Total	Accumulative Total
Litre	Litre
Pint	Gallon
Quart	Gallon
Gallon	Gallon

- 4) To store the selected units, press and hold down the Reset button for five seconds until the batch and accumulative totals appear. If the reset button is not held down for 5 seconds, the original settings will be restored.

Low Battery

The battery segment will flash when the battery is low and needs replacing.

Important: When the battery segment starts flashing replace the battery as soon as possible, use only Alkaline AA batteries.

Battery replacement

- 1) Remove the protective rubber boot.
- 2) Remove the battery cover screw located near the Inline (forward) outlet port and remove the battery cover.
- 3) Replace the two AA Alkaline batteries, note the battery direction label inside the housing.
- 4) Inspect the battery cover seal for damage and replace if necessary.
- 5) Replace battery cover and tighten screw.

Error signal

If an error is detected, the following error code will appear on the display.

- Err1 – Sensor error
- Err3 – Flowrate too high
- Err4 – Calibration error
- Err5 – Computer error

To reset the meter after an error signal press the Reset button.

MAINTENANCE



CAUTION

Before carrying out any maintenance disconnect the air supply to the pump and release the fluid pressure in the system by pressing the lever on the control gun.

Inspect your oil control gun daily for any signs of damage. Replace any damaged parts or components as required.

FIELD CALIBRATION

Field calibration will allow a +/- 5% adjustment to the calibration.

- 1) In manual mode press the CAL button (located under the calibration screw on the underside of the gun) for 5 seconds until Opt n 1 appears. (Refer item 16 page 4).
- 2) Press the CAL button until F Cal appears.
- 3) Press the CAL button until F CAL starts flashing.
- 4) Using an accurate measuring container, fill the container to the desired level. (e.g 5 litres)
- 5) Insert dispensed volume by:
 - a) Press reset button to change the numbers.
 - b) Press Cal button to move to the next number
 - c) Insert the correct dispensed value (e.g 5 litres)
 - d) Press Cal button for 5 seconds - F Cal will stop flashing.
- 6) To store press Reset for 5 seconds until 0.00 appears

CONTROL HANDLE DISASSEMBLY

Use a clean bench to carry out maintenance.

- A) Remove the oil hose from the inlet swivel (26).
- B) Unscrew and remove swivel (26) washer (24) and o'ring (25) from the control gun inlet. Clean or replace the strainer and o'ring.

Caution the swivel is under spring tension

- C) Slide off the handle sleeve (23).
- D) Remove valve spring (22), seal/valve body assembly (20) and plunger (19).

Lever and Valve removal

- A) Using a 2.5mm allen key, remove the 2 handle screws (27).
- B) Remove lever (29).
- C) Remove the washer (18), "O"Ring (17), then push the valve cam (14) from the gun body (13), and remove "O"Ring (17).

CONTROL HANDLE REASSEMBLY

A) Clean and inspect all parts. Replace any suspect, worn or damaged components.

Note: Lightly lubricate the valve cam before assembly.

B) Place "O"Ring (17) onto valve cam (14).

Note: The cut out section in the middle of the valve cam (14) must face the inlet swivel (26).

C) Replace the valve cam (14) into the body (13). Note the orientation shown on the assembly drawing. Fit the second "O"Ring (17) and washer (18).

D) Slide lever assembly (29) into position and replace the two Allen screws (27). (Use Loctite or similar sealant).

E) Replace plunger (19).

Note: The end hole in the plunger must face the meter.

F) Assemble the seal/valve body (20), and spring (22) and replace into the gun body.

Note: Install the spring, small end first.

G) Replace handle sleeve (23).

H) Replace washer (24), o'ring (25) swivel assembly (26), and screw firmly into place (Use Loctite or similar sealant).

Note: After assembly ensure the handle latch is operating correctly.

METER DISASSEMBLY

1) Unscrew the swivel assembly (26) two complete turns to allow easy disassembly and assembly of the meter and remove boot (1).

2) Remove battery cover screw (3), the battery cover (5) and batteries (7).

4) Carefully remove the computer module (2) from the module housing (8).

Note: The computer module is non repairable and will need to be replaced if damaged.

5) Remove the four Allen screws (15) from the underside of the meter and remove the module housing (8).

6) Remove the rotors (11) and the body 'o' ring (12).

3) Remove the three Phillips screws (9) and the calibration port screw (16) from the underside of the meter.

METER REASSEMBLY

1) Clean and inspect all parts. Replace any suspect, worn or damaged components.

2) Replace rotors (11) (Refer to Fig 1).

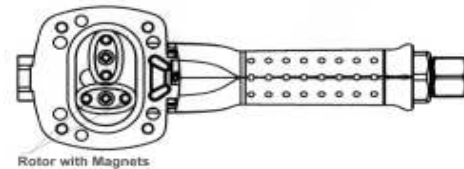

(Fig 1)

Note: Ensure the rotor with the magnets is assembled with the magnets facing up and positioned on the correct side of the meter. Both rotors must also be positioned at 90deg to each other (Refer Fig 1).

3) Replace the gun body 'o'ring (12).

4) Carefully position the module housing (8) on top of the gun body (13), replace and tighten the four Allen screws (15).

5) Ensure the handle latch is working correctly.

6) Test the oil control gun for correct operation.

7) Replace the computer module (2).

8) Replace and tighten the three Phillips head screws (9) and calibration port screw (16).

9) Replace the two AA Alkaline batteries (7). (use the directions on the label found inside the battery housing for correct battery orientation).

10) Replace battery cover assembly (4,5,6) and tighten the screw (3).

11) Firmly tighten the swivel assembly (26).

12) Replace the boot (1).

13) Test oil control gun for correct operation.

TROUBLE SHOOTING GUIDE

TROUBLE	CAUSE	REMEDY
No fluid passing through the meter	a) Blocked strainer	a) Clean or replace strainer
	b) Dirt particles jamming the rotors	b) Dismantle meter assembly and clean (refer to meter disassembly)
	c) Damaged plunger seal	c) Replace damaged plunger seal
The meter is not registering fluid output	a) Flat battery	a) Replace battery
	b) No signal from the magnets	b) Check magnets and replace rotors if required
	c) Damaged computer module	c) Replace computer module
Meter display reads Err 1	Sensor error	Press the reset button to reset the computer. (If the error repeats, check the magnets in the rotor)
Meter display reads Err 3	Flow rate to high	Adjust the flow rate to 1-30 l/min (0.26-8 US gal/min) Eliminate air from the system
Meter display reads Err 4	Calibration error	Press the reset button to reset the computer
Meter display reads Err 5	Computer error	Press the reset button to reset the computer
		Note: Always press the reset button to reset the computer
Constant oil leak from the nozzle	Damaged plunger seal (20)	Replace plunger seal (check for damage)
Intermittent drip from the nozzle	Dirt in the nozzle	Remove the nozzle and blow out any dirt particles, replace if necessary
Oil leak from the lever assembly area	Damaged o'rings (17)	Replace damaged o'rings
Oil leak from between the body casting and the computer module casting	Damaged o'ring (12)	Replace damaged o'ring
Low flow rate	Blocked strainer (32)	Replace strainer
Oil leaking from the swivel inlet	Damaged o'ring or swivel	Replace swivel

SPARE PARTS DIAGRAM

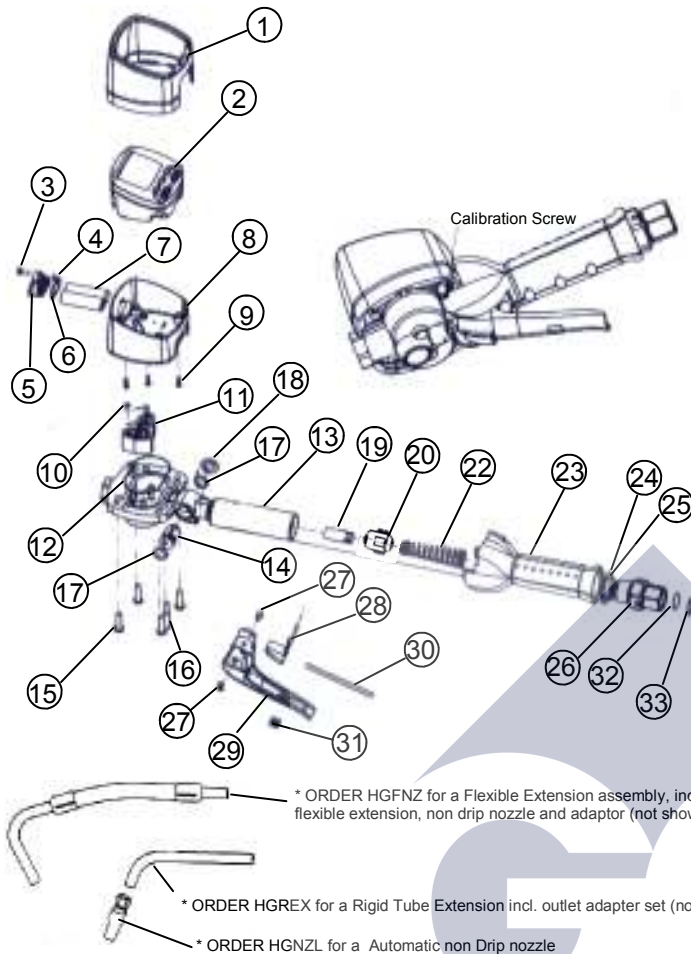

SPARE PARTS LIST

		Order for replacement		
Item	No. off	Part or set	Kit ref	Description
		HG50-1K (KIT A)		Major service kit
		HG50-2K (KIT B) incl		Valve service kit
1	1	HG381BKs		Electronic boot (STD)
2	1	HG369As		Electronic module
3	1		A	Battery cover screw
4	1		A	O'ring (BS007)
5	1			Battery cover
6	1		A	Battery cover insert
7	2	n/a		AA Alkaline batteries
8	1	n/a		Module housing
9	3		A	M3x6 Taptite screws
10	2			Magnets
11	2	HG005s		Oval gear set
12	1		A	O'ring (BS035)
13	1	n/a - new gun req'd		Gun body
14	1		A & B	Valve cam
15	4		A	M6x20 Taptite screws
16	1		A & B	Calibration screw
17	2		A & B	O'ring (BS111)
18	1		A & B	Washer
19	1		A	Plunger
20	1		A & B	Valve body and seal assy
22	1		A & B	Valve spring
23	1			Handle sleeve
24	1		A & B	Washer
25	1		A & B	O'ring (BS117)
26	1	HG040As incl item 24 / BS117		Swivel assy (BSP)
26	1	HG043As incl item 24 / BS117		Swivel assy (NPT)
27	2		A & B	M4x6 Counter sink screws
28	1			Push button manual
29	1			Lever latching
30	1		A	Button spring
31	1		A	Lever plug
32	1		A & B	Mesh
33	1		A & B	O'ring (BS113)

WEEE Directive - Waste Electrical and Electronic Equipment



The WEEE Directive requires the recycling of waste electrical and electronic equipment in the European Union. Whilst the WEEE Directive does not apply to some of Macnaught's products, we support its policy and ask you to be aware of how to dispose of this product. The crossed out wheeled bin symbol illustrated and found on our products signifies that this product should not be disposed of in general waste or landfill. Please contact your local dealer national distributor or Macnaught Technical Services for information on product disposal.

SPECIFICATIONS:

Accuracy:	+ - 0.5% (of Reading) (ISO100 @ 10 l/min)
Flow Range:	1-30 l/min (0.26 – 8 US gal/min)
Maximum Supply Pressure:	103.50 BAR / 10350kPa / 1500 PSI
Pressure Loss:	1Bar/ 100kPa / 14.4PSI @ 12 l/min (3.2 US gal/min) with calibration fluid (6 Centipoise Viscosity) without extension.
Weight:	1.16kg (2.55lbs)
Swivel Inlet:	½" BSPT or ½" NPT
Outlet:	3/8" NPT
Operating Temperature:	-0 to +50 degrees Celsius (32 – 122 degrees F)
Storage Temperature:	-10 to +60 degrees Celsius (14 – 140 degrees F)
Battery:	2 x 1.5Volt AA Batteries (Alkaline batteries are essential for HG60 version)
Wetted Parts:	Aluminium, Acetal, Steel, Nitrile Rubber
Fluid Compatibility:	Engine Oil, Diesel Oil, Automatic Transmission Fluid, Anti-freeze / Anti-Boil Mixture. (Maximum Viscosity SAE140)
Dimensions:	25.8cm (10inch) Long x 9.5 cm (3.7inch) High, 11cm(4.33inch) wide (Dimensions without extension)

Note:

This product should be disposed of according to all applicable local and national government environment regulations and guidelines.



For Warranty Terms and Conditions see macnaught.com.au
For a list of Australian Service Centres see macnaught.com.au