

MIRKA

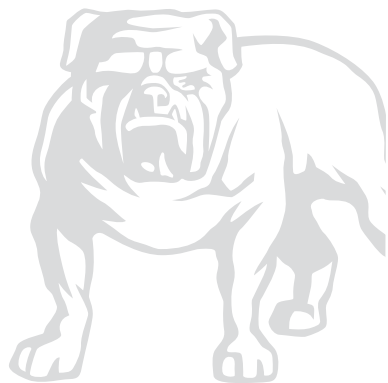

Mirka® ROS

125 mm (5") • 150 mm (6")



Parts Page

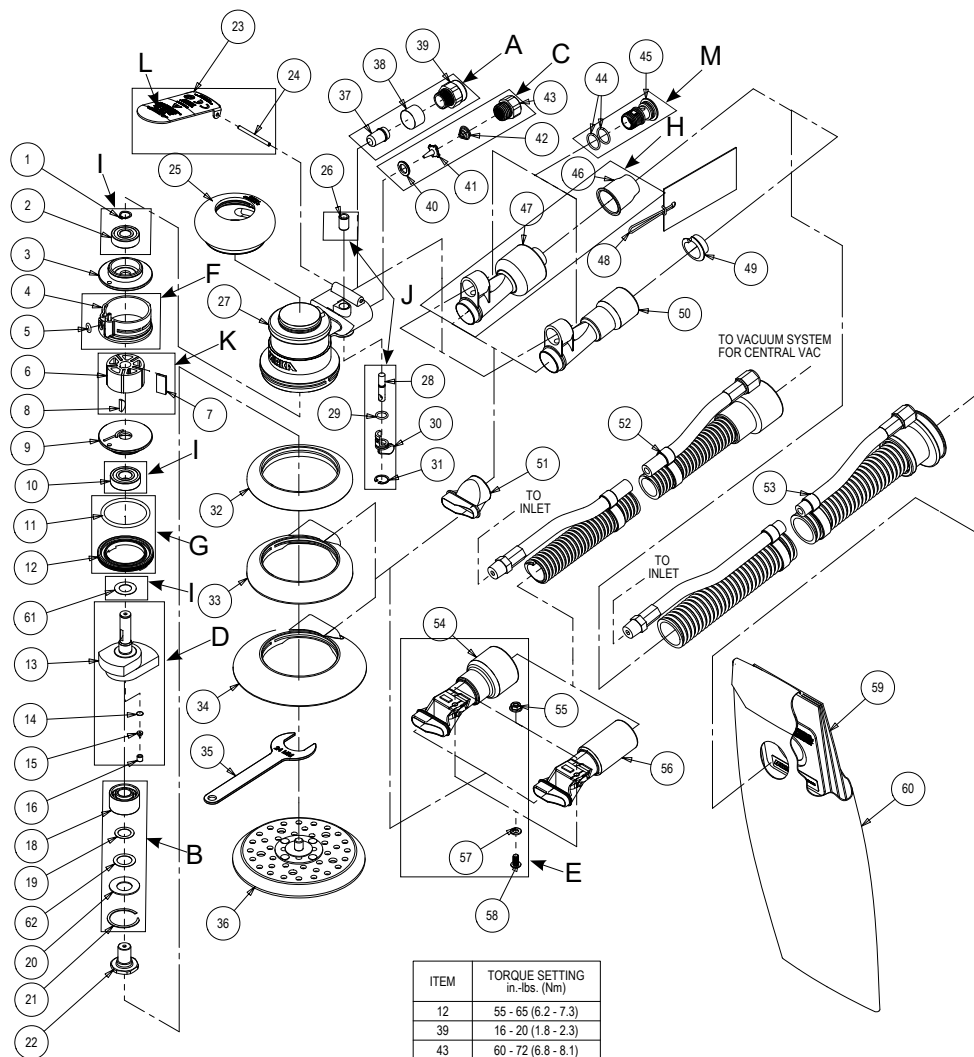

ITEM	TORQUE SETTING in.-lbs. (Nm)
12	55 - 65 (6.2 - 7.3)
39	16 - 20 (1.8 - 2.3)
43	60 - 72 (6.8 - 8.1)
45	36 - 48 (4.0 - 5.4)
58	30 - 35 (3.4 - 3.9)

Parts List

Item	P/N	Description	Qty.
1	MPA0040	RETAINING RING	1
2	MPA0021	BEARING	1
3	MPB0017	REAR ENDPLATE	1
4	MPA0005	CYLINDER ASSEMBLY	1
5	MPA0042	O-RING	1
6	MPB0005	ROTOR	1
7	MPA0010	VANE	5
8	MPA0041	KEY	1
9	MPB0016	FRONT ENDPLATE	1
10	MPA0019	BEARING	1
11	MPA0045	O-RING	1
12	MPA0001	LOCK RING	1
13	MPB0277	5 mm (3/16 in.) ORBIT AirSHIELD™ SHAFT BALANCER FOR 125 mm (5 in.) PADS	1
	MPB0278	5 mm (3/16 in.) ORBIT AirSHIELD™ SHAFT BALANCER FOR 150 mm (6 in.) PADS	1
	MPB0279	2.5 mm (3/32 in.) ORBIT AirSHIELD™ SHAFT BALANCER FOR 125 mm (5 in.) PADS	1
	MPB0280	2.5 mm (3/32 in.) ORBIT AirSHIELD™ SHAFT BALANCER FOR 150 mm (6 in.) PADS	1
14	MPA0122	FILTER	1
15	MPA0121	CHECK VALVE	1
16	MPA0120	RETAINER	1
17	N/A		
18	MPA0938	DOUBLE ROW BEARING	1
19	MPA0016	SPACER	1
20	MPA0017	WASHER	1
21	MPA0018	RETAINING RING	1
22	MPB0018	SPINDLE	1
23	MPA1699	LEVER FOR 12,000 rpm, 125 mm (5 in.) / 150 mm (6 in.) PADS 5 mm (3/16 in.) ORBIT MACHINES	1
	MPA1698	LEVER FOR 12,000 rpm, 125 mm (5 in.) / 150 mm (6 in.) PADS 2.5 mm (3/32 in.) ORBIT MACHINES	1
24	MPA0031	PIN	1
25	MPA0288	65 mm (2 1/2 in.) GRIP (Optional)	OPTIONAL
	MPA0289	70 mm (2 3/4 in.) GRIP (Optional)	OPTIONAL
	MPA0290	75 mm (3 in.) GRIP (Standard)	1
26	MPA0015	SLEEVE	1
27	MPA0244	HOUSING	1
28	MPA0008	VALVE STEM ASSEMBLY	1
29	MPA0043	O-RING	1
30	MPB0014	SPEED CONTROL	1
31	MPA0039	RETAINING RING	1
32	MPB0012	125/150 mm (5/6 in.) NON-VACUUM SHROUD	1
33	MPC0012	SuperVAC™ SHROUD for 125 mm (5 in.) Delta, TE, LP and Screen Abrasive pads	1
34	MPC0073	SuperVAC™ SHROUD for 150 mm (6 in.) Screen Abrasive and LP Pads	1
35	MPA0022	24 mm PAD WRENCH (supplied with each tool)	1
36	NA	SEE LITERATURE FOR PADS (type/size determined by model)	1
37	MPA0062	INTERNAL MUFFLER (for 12,000 rpm Machines)	1
38	MPA0068	MUFFLER INSERT (for 12,000 rpm Machines)	1
39	MPA0166	MUFFLER HOUSING	1
40	MPA0009	SEAT	1
41	MPA0007	VALVE	1
42	MPA0014	VALVE SPRING	1
43	MPA0013	INLET BUSHING	1
44	MPA0044	O-RING	2
45	MPA0006	DB RETAINER	1
46	MPA0778	28mm (1 in.) HOSE SEAL	1
47	MPA0410	28 mm (1 in.) HOSE SuperVAC™ DB SWIVEL EXHAUST ASSEMBLY (Standard for DB))	1
48	MPA0856	19mm (3/4 in.) HOSE SEAL TAG	OPTIONAL
	MPA0931	28mm (1 in.) HOSE SEAL TAG	1
49	MPA0854	19mm (3/4 in.) HOSE SEAL	OPTIONAL
50	MPA0409	19 mm (3/4 in.) HOSE SuperVAC™ DB SWIVEL EXHAUST ASSEMBLY (Optional for DB)	OPTIONAL
51	MPC0108	SuperVAC™ DB EXHAUST ADAPTER (for use with SuperVAC™ Shroud)	1
52	MPA0300	Ø 19 mm (3/4 in.) VAC HOSE TO Ø 19 mm (3/4 in.) x Ø 28 mm (1 in.) HOSE ADAPTER COUPLING AND AIRLINE ASSEMBLY INCLUDES: MPA0200 Ø 19 mm (3/4 in.) x 1.5 m (5 ft.) Vacuum Hose, MPB0088 19 mm (3/4 in.) Hose x 28 mm (1 in.) Hose Adapter, MPA0302 Ø 6.3 mm (1/4 in.) x 1.5 m (5 ft.) Airline with Fittings, MPA0301 Bungee for Ø 6.3 mm (1/4 in.) Airline & Ø 19 mm (3/4 in.) Vacuum Hose (5)	OPTIONAL
	MPA0392	Ø 28 mm (1 in.) VAC HOSE TO Ø 28 mm (1 in.) x Ø 38 mm (1 1/2 in.) FRICTION FIT ADAPTER AND AIRLINE ASSY. (Optional) INCLUDES: MPA0034 Ø 28 mm (1 in.) x 1.8 m (6 ft.) Vacuum Hose, MPB0092 Ø 28 mm (1 in.) Hose Thread x Ø 38 mm (1 1/2 in.) Friction Fit Adapter, MPA0033 Ø 6.3 mm (1/4 in.) x 1.8 m (6 ft.) Airline with Fittings, MPA0027 Bungee for Ø 6.3 mm (1/4 in.) Airline & Ø 28 mm (1 in.) Vacuum Hose (5)	OPTIONAL
53	MPA0412	Ø 28 mm (1 in.) VAC HOSE TO Ø 28 mm (1 in.) DOUBLE BAG FITTING AND AIRLINE ASSY. (Standard for DB) INCLUDES: MPA0034 Ø 28 mm (1 in.) x 1.8 m (6 ft.) Vacuum Hose, MPB0123 Ø 28 mm (1 in.) Hose to Double Bag Vacuum Fitting, MPA0033 Ø 6.3 mm (1/4 in.) x 1.8 m (6 ft.) Airline with Fittings, MPA0027 Bungee for Ø 6.3 mm (1/4 in.) Airline & Ø 28 mm (1 in.) Vacuum Hose (5)	1
	MPA0411	Ø 19 mm (3/4 in.) VAC HOSE TO Ø 19 mm (3/4 in.) DOUBLE BAG FITTING AND AIRLINE ASSEMBLY (Optional for DB) INCLUDES: MPA0200 Ø 19 mm (3/4 in.) x 1.5 m (5 ft.) Vacuum Hose, MPB0133 Ø 19 mm (3/4 in.) Hose To Double Bag Vacuum Fitting, MPA0302 Ø 6.3 mm (1/4 in.) x 1.5 m (5 ft.) Airline with Fittings, MPA0301 Bungee for Ø 6.3 mm (1/4 in.) Airline & Ø 19 mm (3/4 in.) Vacuum Hose (5)	OPTIONAL
54	MPA0099	SuperVAC™ CV 28 mm (1 in.) SWIVEL EXHAUST ASSEMBLY (Standard for CV)	1
55	MPA0048	NUIT	1
56	MPA0205	SuperVAC™ CV 19 mm (3/4 in.) SWIVEL EXHAUST ASSEMBLY (Optional for CV)	OPTIONAL
57	MPA0047	WASHER	1
58	MPA0769	SCREW	1
59	MPA0465	10 PACK OF VACUUM BAG INSERTS	1
60	MPA0658	VACUUM BAG	1
61	MPA2541	FRONT BEARING DUST SHIELD	1
62	MPA2542	SPINDLE BEARING DUST SHIELD	1

Sander Spare Parts Kits

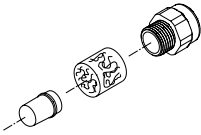

A MPA0797 12,000 rpm
Muffler Kit
Code: 8993017311

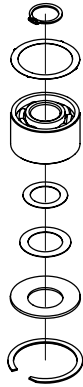

B MPA0802 ROS
Spindle Bearing Kit
Code: 8993019711

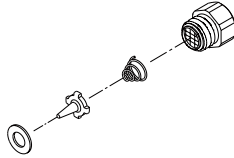

C MPA0798 Air Inlet Kit
Code: 8993018811

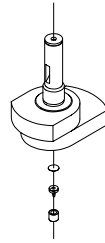

D MPA0980 Shaft Balancer Kit
150mm/5.0 Kit
Code: 8993010611
MPA1670 Shaft Balancer Kit
150mm/2.5 Kit
Code: 8993013711

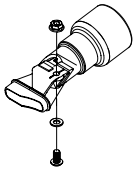

E MPA0988 CV Swivel
Fitting Kit
Code: 8993006611

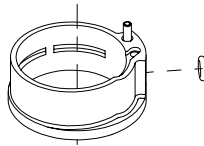

F MPA0994 Cylinder & O-ring Kit
Code: 8993009211

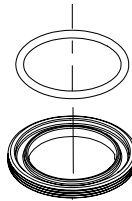

G MPA0993 Lock Ring &
O-ring Kit
Code: 8993007911

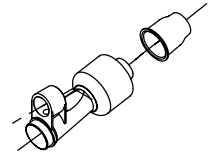

H MPA0932 DB Swivel
Fitting Kit
Code: 8993011311

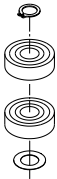

I MPA0799 Endplate
Bearing Kit
Code: 8993019811

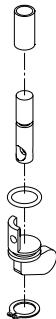

J MPA0800 Speed
Valve Kit
Code: 8993019011

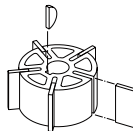

K MPA0801 Rotor, Vanes
& Key Kit
Code: 8993017711



L MPA0983 Lever Kit
5.0 mm orbit
Code: 8993010811
MPA0984 Lever Kit
2.5 mm orbit
Code: 8993010911

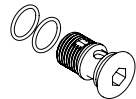

M MPA2551 DB
Retainer Kit
Code: 8993018911

MIRKA

Mirka 12,000 rpm 125 mm (5 in.) & 150 mm (6 in.) RANDOM ORBITAL SANDERS

Declaration of conformity

Mirka Ltd.

66850 Jeppo, Finland

declare on our sole responsibility that the products

125 mm (5 in.) and 150 mm (6 in.) 12,000 rpm Random Orbital Sanders (see "Product Configuration/Specifications" Table for particular model) to which this declaration relates are in conformity with the following standard(s) or other normative document(s): EN ISO 12100:2010, EN ISO 11148-8:2011, EN ISO 15744:2008 & EN ISO 28927-3:2009 in accordance with the regulation 2006/42/EC.

Jeppo 23.06.2020

Place and date of issue

MIRKA

Company



Stefan Sjöberg, CEO

Operator Instructions

Includes – Please Read and Comply, Proper Use of Tool, Work Stations, Putting the Tool Into Service, Operating Instructions, Product Configuration/Specifications Tables, Parts Page, Parts List, Sander Spare Parts Kits, Troubleshooting Guide.

Important

Read these instructions carefully before installing, operating, servicing or repairing this tool. Keep these instructions in a safe accessible location.



Manufacturer/Supplier

Mirka Ltd.
66850 Jeppo, Finland
Tel: + 358 20 760 2111



Required Personal Safety Equipment

Safety Glasses Breathing Masks
Safety Gloves Ear Protection

WARNING

Always wear required personal safety protection in accordance with manufacturer's instructions and local/national standards while using this tool.

- Do not use a power tool if you are tired or under the influence of drugs, alcohol or medication.
- Read the Materials Safety Data Sheet (MSDS) for the working surface.
- Use the tool with dust extraction. A suitable dust extraction unit will reduce hazardous dust.
- Do not overreach. Keep proper footing and balance at all times.
- Do not wear loose clothing or jewellery. Keep your hair, clothing and gloves away from moving parts. Loose clothes, jewellery or long hair can be caught in moving parts.
- If any physical hand/wrist discomfort is experienced, stop working and seek medical attention. Hand, wrist and arm injury may result from repetitive work, motion and overexposure to vibrations.
- Do not operate power tools in explosive atmospheres, such as in the presence of flammable liquids, gases or dust.
- The tool is not electrically insulated. Check work area for live electricity, gas pipes, etc. before operation.

CAUTION

- Prevent unintentional starting.
- Remove pad wrench before connecting the tool to the air supply.
- Keep work area clean and well lit.
- Always ensure that the work piece to be sanded is firmly fixed.
- Before changing abrasive always disconnect the air supply.

Additional safety warnings

- Read all instructions before using this tool. All operators must be fully trained in usage and safety of this tool.
- All maintenance must be carried out by trained personnel. For service, contact Mirka authorized service centre!
- Always wear required safety equipment (see warnings).
- The operator must be in a secure position and have a firm grip and footing on a solid floor.
- Always ensure that the work piece to be sanded is firmly fixed.
- Check tool, backing pad, hose and fittings regularly for wear.
- Always take care to ensure your safety at work; never carry, store or leave the tool unattended with the air supply connected.
- Vacuum unit dust collection bag should be cleaned or replaced daily. Dust can be highly combustible. Cleaning or replacing of bag also assures optimum performance.
- Do not exceed maximum recommended air pressure of 6.2 bar (90 psi).
- Take care to avoid entanglement of the moving parts of the tool with clothing, ties, hair, cleaning rags, etc.
- Keep hands clear of the spinning pad during use.
- If the tool appears to malfunction, remove from use immediately and arrange for service and repair.
- Before changing abrasive always disconnect the air supply. Take care to properly attach and centre the abrasive on the backing pad.

Please Read and Comply with

- 1) General Industry Safety & Health Regulations, Part 1910, OSHA 2206, available from: Superintendent of Documents; Government Printing Office; Washington DC 20402
- 2) Safety Code for Portable Air Tools, ANSI B186.1 available from: American National Standards Institute, Inc.; 1430 Broadway; New York, New York 10018
- 3) State and Local Regulations.

Proper Use of Tool

This sander is designed for sanding all types of materials i.e. metals, wood, stone, plastics, etc. using abrasive designed for this purpose. Do not use this sander for any other purpose than that specified without consulting the manufacturer or the manufacturer's authorized supplier. Do not use backing pads that have a working speed less than 12,000 rpm free speed.

Work Stations

The tool is intended to be operated as a hand-held tool. It is always recommended that the tool be used when standing on a solid floor. It can be used in any position but before any such use, the operator must be in a secure position and have a firm grip and footing, and be aware that the sander can develop a torque reaction. See the section "Operating Instructions".

Operating Instructions

- 1) Read all instructions before using this tool. All operators must be fully trained in its use and be aware of these safety rules. All servicing and repairs must be carried out by trained personnel.
- 2) Make sure the tool is disconnected from the air supply. Select a suitable abrasive and secure it to the backing pad. Take care to center the abrasive on the backing pad.
- 3) Always wear the required safety equipment when using this tool.
- 4) When sanding always place the tool on the work then start the tool. Always remove the tool from the work before stopping. This will prevent gouging of the work due to excess speed of the abrasive.
- 5) Always disconnect the air supply from the sander before fitting, adjusting or removing the abrasive or backing pad.
- 6) Always adopt a firm footing and/or position and be aware of torque reaction developed by the sander.
- 7) Use only correct spare parts.
- 8) Always ensure that the material to be sanded is firmly fixed to prevent its movement.
- 9) Check hose and fittings regularly for wear. Do not carry the tool by its hose; always be careful to prevent the tool from being started when carrying the tool with the air supply connected.
- 10) Dust can be highly combustible. The vacuum dust collection bag should be cleaned or replaced daily. Cleaning or replacement of the bag also assures optimum performance.
- 11) Do not exceed the maximum recommended air pressure. Use safety equipment as recommended.
- 12) The tool is not electrically insulated. Do not use where there is a possibility of coming into contact with live electricity, gas pipes, water pipes, etc. Check the working area before operation.
- 13) Take care to avoid entanglement of the moving parts of the tool with clothing, ties, hair, cleaning rags, etc. If entangled, it will cause the body to be pulled towards the work and moving parts of the machine and can be very dangerous.
- 14) Keep hands clear of the spinning pad during use.
- 15) If the tool appears to malfunction, remove from use immediately and arrange for servicing and repair.
- 16) Do not allow the tool to free-speed without taking precautions to protect any persons or objects from the loss of the abrasive or pad.

Putting the Tool into Service

Use a clean lubricated air supply that will give a measured air pressure at the tool of 6.2 bar (90 psig) bar when the tool is running with the lever fully depressed. It is recommended to use an approved 10 mm (3/8 in.) x 8 m (25 ft) maximum length airline. It is recommended that the tool be connected to the air supply as shown in Figure 1.

Do not connect the tool to the airline system without incorporating an easy to reach and operate air shut-off valve. The air supply should be lubricated. It is strongly recommended that an air filter, regulator and lubricator (FRL) be used as shown in Figure 1 as this will supply clean, lubricated air at the correct pressure to the tool. Details of such equipment can be obtained from your supplier. If such equipment is not used then the tool should be manually lubricated.

To manually lubricate the tool, disconnect the airline and put 2 to 3 drops of suitable pneumatic motor lubricating oil such as Fuji Kosan FK-20, Mobil ALMO 525 or Shell TORCULA® 32 into the hose end (inlet) of the machine. Reconnect the tool to the air supply and run the tool slowly for a few seconds to allow air to circulate the oil. If the tool is used frequently, lubricate it on a daily basis or lubricate it if the tool starts to slow or lose power. It is recommended that the air pressure at the tool is 6.2 bar (90 psig) while the tool is running. The tool can run at lower pressures but never higher than 6.2 bar (90 psig).

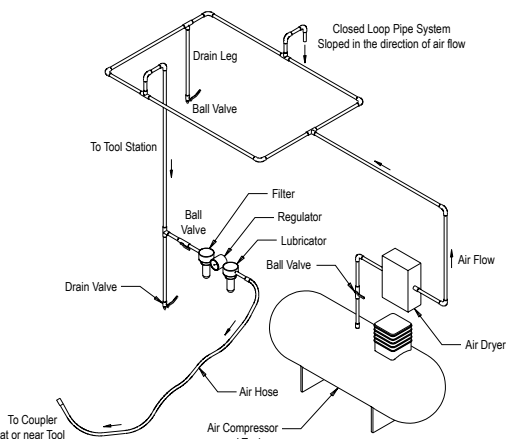

Technical data

Mirka® ROS	525CV	525NV	550CV	550DB	550NV	625CV	625DB	625NV	650CV	650DB	650NV
Recommended Airline Size - Minimum	10 mm 3/8 in										
Recommend Maximum Hose Length	8 meters 25 feet										
Air Pressure - Maximum Working Pressure	6.2 bar 90 psig										
Air Pressure - Recommended Minimum	NA										

Product Configuration/Specifications: 12,000 rpm Random Orbital Sander

Orbit	Vacuum Type	Pad Size mm (inch)	Model Number	Product Net Weight kg (pounds)	Height mm (inch)	Length mm (inch)	*Noise Level dBA	Power watts (HP)	Air Consumption LPM (scfm)	*Vibration Level m/s ²	*Uncertainty K m/s ²
2.5 mm (3/32 in.)	Non-Vacuum	125 (5)	ROS525NV	0.72 (1.59)	82.9 (3.26)	148.4 (5.84)	79.0	209 (0.28)	481 (17)	2.10	1.10
		150 (6)	ROS625NV	0.76 (1.68)	82.9 (3.26)	161.1 (6.34)	83.0	209 (0.28)	481 (17)	3.30	1.70
	Central Vacuum	125 (5)	ROS525CV	0.78 (1.72)	87.7 (3.45)	148.4 (5.84)	78.0	209 (0.28)	481 (17)	2.29	0.72
		150 (6)	ROS625CV	0.85 (1.87)	82.9 (3.26)	161.1 (6.34)	79.0	209 (0.28)	481 (17)	2.14	0.71
	Shrouded Self-Gen. Vacuum	150 (6)	ROS625DB	0.85 (1.87)	82.9 (3.26)	164.1 (6.46)	84.0	209 (0.28)	481 (17)	2.11	0.70
5.0 mm (3/16 in.)	Non-Vacuum	125 (5)	ROS550NV	0.75 (1.65)	82.9 (3.26)	149.6 (5.89)	80.0	209 (0.28)	481 (17)	2.60	1.30
		150 (6)	ROS650NV	0.79 (1.74)	82.9 (3.26)	162.3 (6.39)	79.0	209 (0.28)	481 (17)	3.70	1.90
	Central Vacuum	125 (5)	ROS550CV	0.81 (1.79)	87.7 (3.45)	149.6 (5.89)	75.5	209 (0.28)	481 (17)	2.77	0.77
		150 (6)	ROS650CV	0.85 (1.87)	82.9 (3.26)	162.3 (6.39)	78.0	209 (0.28)	481 (17)	2.48	0.74
	Shrouded Self-Gen. Vacuum	125 (5)	ROS550DB	0.83 (1.83)	87.7 (3.45)	152.6 (6.01)	83.0	209 (0.28)	481 (17)	2.11	0.70
		150 (6)	ROS650DB	0.88 (1.94)	82.9 (3.26)	165.3 (6.51)	83.0	209 (0.28)	481 (17)	2.00	0.69

The noise test is carried out in accordance with EN ISO 15744:2008 - Hand-held non-electric power tools -- Noise measurement code -- Engineering method (grade 2) and EN ISO 11203:2009 Acoustics-Noise emitted by machinery and equipment-Determination of emission sound pressure levels at a work station and other specified positions from the sound power level.

The vibration test is carried out in accordance with EN ISO 28927-3, Hand-held portable power tools – Test method for evaluation of vibration emission – Part 3: Polishers and rotary , orbital and random orbital sanders.

Specifications subject to change without prior notice.

*The values stated in the table are from laboratory testing in conformity with stated codes and standards and are not sufficient for risk evaluation. Values measured in a particular work place may be higher than the declared values. The actual exposure values and amount of risk or harm experienced to an individual are unique to each situation and depend upon the surrounding environment, the way in which the individual works, the particular material being worked, work station design as well as upon the exposure time and the physical condition of the user. Mirka, Ltd. cannot be held responsible for the consequences of using declared values instead of actual exposure values for any individual risk assessment.

Further occupational health and safety information can be obtained from the following websites:

<https://osha.europa.eu/en> (Europe)

<http://www.osha.gov> (USA)

Troubleshooting Guide

Symptom	Possible Cause	Solution
Low power and/or low free speed.	Insufficient air pressure.	Check air line pressure at the Inlet of the Sander while the tool is running at free speed. It must be 6.2 Bar (90 psig/620 kPa).
	Clogged Muffler(s).	See the "Housing Disassembly" section for Muffler removal. The Item 37 Muffler can be back flushed with a clean, suitable cleaning solution until all contaminants and obstructions have been removed. If the Muffler can not be properly cleaned then replace it. Replace Item 38, Muffler Insert (See the "Housing Assembly" Section).
	Plugged Inlet Screen.	Clean the Inlet Screen with a clean, suitable cleaning solution. If the Screen cannot be cleaned, replace it.
	One or more worn or Broken Vanes.	Install a complete set of new Vanes (all vanes must be replaced for proper operation). Coat all vanes with quality pneumatic tool oil. See "Motor Disassembly" and "Motor Assembly".
	Internal air leakage in the Motor Housing indicated by higher than normal air consumption and lower than normal speed.	Check for proper Motor alignment and Lock Ring engagement. Check for damaged O-Ring in Lock Ring groove. Remove Motor Assembly and re-install the Motor Assembly. See "Motor Disassembly" and "Motor Assembly".
	Motor parts worn.	Overhaul Motor. Contact authorized Mirka Service Center.
	Worn or broken Spindle Bearings	Replace the worn or broken Bearings. See "Shaft Balancer and Spindle Disassembly" and "Spindle Bearings, AirSHIELD™ and Shaft Balancer Assembly".
Air leakage through the Speed Control and/or Valve Stem.	Dirty, broken or bent Valve Spring, Valve or Valve Seat.	Disassemble, inspect and replace worn or damaged parts. See steps 2 and 3 in "Housing Disassembly" and steps 2 and 3 in "Housing Assembly".
Vibration/rough operation.	Incorrect Pad.	Only use Pad sizes and weights designed for the machine.
	Addition of interface pad or other material.	Only use abrasive and/or interface designed for the machine. Do not attach anything to the Sanders Pad face that was not specifically designed to be used with the Pad and Sander.
	Improper lubrication or buildup of foreign debris.	Disassemble the Sander and clean in a suitable cleaning solution. Assemble the Sander. (See "Service Manual".)
	Worn or broken Rear or Front Motor Bearing(s).	Replace the worn or broken Bearings. See "Motor Disassembly" and "Motor Assembly".
	For vacuum machines it is possible to have too much vacuum while sanding on a flat surface causing the pad to stick to the sanding surface.	For DB machines add extra washer(s) to the pad spindle to increase the gap between the pad and shroud. For CV machines reduce vacuum through the vacuum system and/or add extra washer(s) to the pad.



Mirka Ltd
Finland

Brazil Mirka Brasil Ltda.

Belgium Mirka Belgium Logistics NV

Canada Mirka Canada Inc.

China Mirka Trading Shanghai Co., Ltd

Finland & Baltics Mirka Ltd

France Mirka France Sarl

Germany Mirka GmbH

India Mirka India Pvt Ltd

Italy Mirka Italia s.r.l., Cafro S.p.A.

Mexico Mirka Mexicana S.A. de C.V.

Russia Mirka Rus LLC

Singapore Mirka Asia Pacific Pte Ltd

Spain Mirka Ibérica S.A.U.

Sweden Mirka Scandinavia AB

Turkey Mirka Turkey Zımpara Ltd Şirketi

United Kingdom Mirka (UK) Ltd

United Arab Emirates Mirka Middle East FZCO

USA Mirka USA Inc.

For contact information,
please visit www.mirka.com

Dedicated to the finish

