

RUPES®



Via Marconi, 3/A - Loc. Vermezzo
20071 Vermezzo con Zelo (MI) - ITALY
Tel +39 02 946941 - Fax +39 02 94941040
info_rupes@rupes.it - www.rupes.com

HSE73 - HSR73 - HSS73

3 IT	Levigatrice	ISTRUZIONI ORIGINALI PER L'USO
7 EN	Sander	ORIGINAL OPERATING INSTRUCTIONS
11 FR	Ponceuse	TRADUCTION DES INSTRUCTIONS DE FONCTIONNEMENT ORIGINALES
15 DE	Schleifer	ÜBERSETZUNG DES ORIGINAL BETRIEBSANLEITUNG
19 ES	Lijadora	TRADUCCIÓN DEL MANUAL DE INSTRUCCIONES ORIGINAL
23 PT	Lixadora	TRADUÇÃO DAS INSTRUÇÕES DE OPERAÇÃO ORIGINAIS
27 NL	Schuurmachine	VERTALING VAN ORIGINELE GEBRUIKSAANWIJZING
31 FI	Hiomakone	ALKUPERÄISTEN KÄYTTÖOHJEIDEN KÄÄNNÖS
35 DA	Slibemaskine	OVERSÆTTELSE AF ORIGINALE BETJENINGSINSTRUKTIONER
39 NO	Slipemaskin	OVERSETTELSE AV ORIGINAL DRIFTSINSTRUKS
43 SV	Slipmaskin	ÖVERSÄTTNING AV ORIGINAL DRIFTSINSTRUKTIONER
47 RU	Шлифовальная машина	ПЕРЕВОД ОРИГИНАЛЬНОЙ ИНСТРУКЦИИ ПО ЭКСПЛУАТАЦИИ
51 PL	Szlifierka	TŁUMACZENIE ORYGINALNYCH INSTRUKCJI OBSŁUGI
55 EL	Τριβείο	ΜΕΤΑΦΡΑΣΗ ΠΡΩΤΟΤΥΠΩΝ ΟΔΗΓΙΩΝ ΛΕΙΤΟΥΡΓΙΑΣ
59 BG	Шлифмашина	ПРЕВОД НА ОРИГИНАЛНИ ИНСТРУКЦИИ ЗА ЕКСПЛОАТАЦИЯ
63 CS	Bruska	PŘEKLAD ORIGINÁLNÍHO NÁVODU K OBSLUZE
67 ET	Lihvija	ORIGINAALKASUTUSJUHENDI TÕLGE
71 HI	सैंडर	इस्तेमाल के लिए मूल निर्देशों का अनुवाद
75 HU	Csiszoló	AZ EREDETI HASZNÁLATI UTASÍTÁS FORDÍTÁSA
79 LV	Slīpmašīna	ORIGINĀLĀS LIETOŠANAS INSTRUKCIJAS TULKOJUMS
83 LT	Šlifuoכליס	ORIGINALŲ NAUDOJIMO INSTRUKCIJŲ VERTIMAS
87 RO	Şlefuitor	TRADUCEREA INSTRUCŢIUNILOR ORIGINALE DE OPERARE
91 SL	Brusilnik	PREVOD IZVIRNIH NAVODIL ZA DELOVANJE
95 SK	Brúska	PREKLAD ORIGINÁLNEHO NÁVODU NA OBSLUHU
99 TR	Zımpara makinesi	ORİJİNAL KULLANIM TALİMATLARININ TERCÜMESİ
103 AR	جلاخة	ترجمة تعليمات التشغيل الأصلية
107 ZH	砂輪磨光机	操作说明书原件翻译
111 JA	サンダ	元の操作手順の翻訳



CONSERVARE QUESTE ISTRUZIONI • SAVE THESE INSTRUCTIONS • CONSERVER CES INSTRUCTIONS • DIESE ANWEISUNGEN AUFBEWAHREN • CONSERVE ESTAS INSTRUCCIONES • GUARDAR ESSAS INSTRUÇÕES • BEWAAR DEZE INSTRUCŢIES • SĀILYTĀ NĀMĀ OHJEET • GEM DISSE INSTRUKTIONER • SPARA DESSA INSTRUKTIONER • РЕКОМЕНДУЕТСЯ ХРАНИТЬ ЭТО РУКОВОДСТВО С ИНСТРУКЦИЯМИ • ZACHOWAJ TE INSTRUKCJE • ΟΙ ΟΔΗΓΙΕΣ ΧΡΗΣΗΣ ΘΑ ΠΡΕΠΕΙ ΝΑ ΦΥΛΑΣΣΟΝΤΑΙ • СЪХРАНЕТЕ ТЕЗИ ИНСТРУКЦИИ • USCHOVEJTE TYTO POKYNY • HOIDKE JIHEND ALLES • इन नद्श को सुरत रर • ÖRIZZE MEG AZ ÚTMUTATÓT • GLAB JIET ŠO INSTRUKCIJU • SAUGOKITE ŠIAS INSTRUKCIJAS • SALVAŢI AŢESTE INSTRUCŢIUNI • SHRANITE TA NAVODILA • USCHOVAJTE TIETO POKYNY • BU TALIMATLAR KİTAPÇIĞINI MUHAFAZA EDİNİZ • احفظ هذه التعليمات • 保存该使用说明书 • 説明書は保存しておいてください

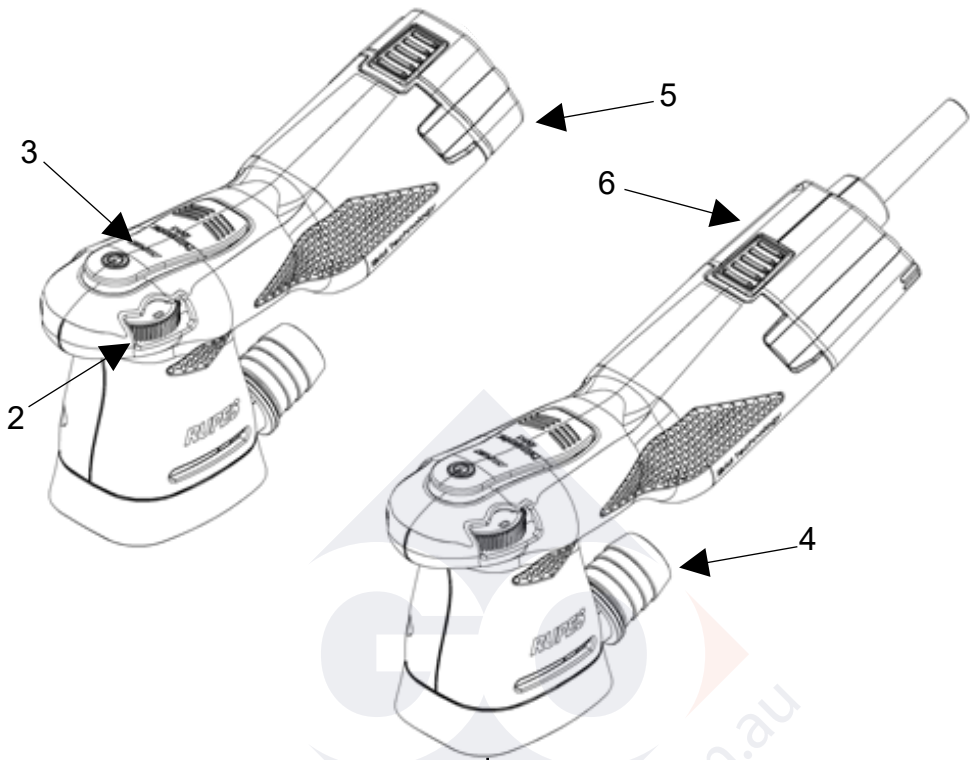

HSE73

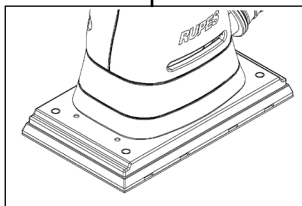
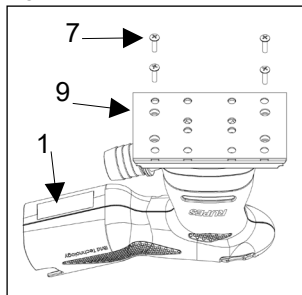

fig. 1



HSR73

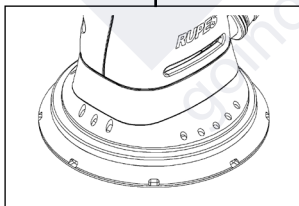
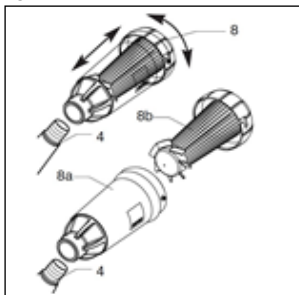

fig. 2



HSS73

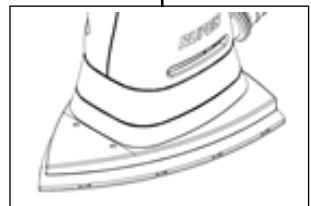
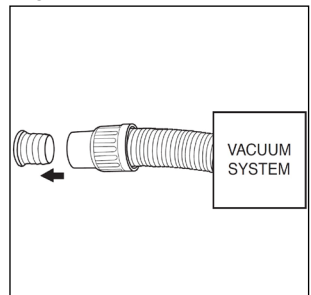









fig. 3



Summary of device labels containing safety information			
	WARNING: To reduce the risk of injury, user must read instruction manual		
	CE marking for EU market		
	Wear ear protection		Wear eye protection
	Wear gloves		Wear a mask
	Disposal of decommissioned (WEEE Directive)		
Li-Ion	Product contains lithium-ion battery		Direct Current

TECHNICAL SPECIFICATIONS

TYPE	HSE73	HSR73	HSS73
Voltage D.C. [V]	18	18	18
R.P.M.	7000 ÷ 11000	7000 ÷ 11000	7000 ÷ 11000
Electronic speed control	•	•	•
Battery life [min]	~45*	~45*	~45*
Ø Orbit [mm]	2	2	2
Pad shape	Rectangular	Circular	Delta
Sanding pad dimensions [mm]	80x130	Ø125	-
Self generated dust extraction	•	•	•
Weight [Kg]	1,0**	1,0**	1,0**

* The value is referred to a use of the battery pack 9HB180LT, fully charged with the charger 9HC180LT.

** measured without the functional units: battery pack or power supply.

⚠ WARNING! Read all safety warnings, instructions, illustrations and specifications provided with this power tool. Failure to follow all instructions listed below may result in electric shock, fire and/or serious injury. **Save all warnings and instructions for future reference.** The safety and accident prevention instructions are reported in the **“SAFETY INSTRUCTION”** booklet which is an integral part of these documents. This **operating instructions manual** indicates the additional information required for the specific use of the tool.

CORRECT USAGE

- **This tool is designed to be used as a sander.** Types HSE73 and HSS73 are orbital sanders, type HSR73 is a random orbit sander.
- **This tool is not intended to be used for metal brushing, polishing and cutting operations.** The use of this tool for unintended applications may cause hazards and injuries to people.
- **The tool must be used with accessories that have been specifically designed or recommended by the manufacturer.** The fixing of the accessory to the tool does not guarantee a safe operation.
- **The rated speed of the accessories must be at least equivalent to the maximum speed specified on the tool.** Using the accessories at speeds above the rated one, may cause them to break or be thrown into the air.
- **The external diameter and thickness of the accessories must match the specifications of the tool.** Accessories with incorrect dimensions cannot be adequately protected or controlled.
- **The configuration of accessories must match the tool.** The use of accessories that cannot be perfectly fitted on the tool may result in imbalance, excessive vibrations and in the impossibility of controlling the tool.
- **Do not use damaged accessories. Before use, inspect all the accessories. Inspect the supporting pads and verify there are no cracks, tears or excessive wear. If the tool or accessory has fallen, verify that it is not damaged or install a new accessory. After inspecting or installing an accessory, test the operation of the tool at maximum speed and without load for one minute, keeping at a safety distance.** If the accessories are damaged, they will break during this test.

PARTS OF THE TOOL

- 1 - Identification plate
- 2 - ON/OFF – Speed regulation knob
- 3 - START/STOP switch lever
- 4 - Backing pad
- 5 - Battery Pack 9HB180LT
- 6 – Power supply 9HP180LT
- 7 – Pad fixing screws
- 8 – Conical filter
- 9 – Sanding pad

STARTING UP

 **WARNING: To reduce the risk of injury, only the 18V Li-ION Battery Pack 9HB180LT (5) or the power supply 9HP180LT (6) should be used with this product.**

Since the batteries, other than those offered by RUPES, have not been tested with this product, use of such batteries with this tool could cause the injury and property damage.

MAGNETS

 **WARNING: Magnets produce a far-reaching, strong magnetic field.**



They could damage tvs and laptops, computer hard drives, credit and atm cards, data storage media, mechanical watches, hearing aids and speakers. Keep magnets away from devices and objects that could be damaged by strong magnetic fields.

 **WARNING: It contains magnets. Magnets could affect the functioning of pacemakers and implanted heart defibrillators. Please avoid contacts with the tool if you or someone near you has a Pacemaker. Avoid damage of the Pacemaker.**

- A pacemaker could switch into test mode and cause illness.
- A heart defibrillator may stop working.
- If you wear these devices keep sufficient distance to magnets.
- Warn others who wear these devices from getting too close to magnets.

Magnets are contained into the flange, into the backing pads and into the DC motor.

BATTERY PACK (PROVIDED OR OPTIONAL)

  **WARNING: For your personal safety, READ and UNDERSTAND the instruction manual of Battery pack 9HB180LT before using.**

 **WARNING: Avoid short circuiting the contacts. Avoid mechanical damage of the battery pack. Do not open or disassemble. Advice on protection against fire and explosion. Keep away from open flames, hot surfaces and sources of ignition.**

Temperature in excess of 45°C reduce the performance of the battery pack. Avoid extended exposure to heat or sunshine. Storage at room temperature (approx. 20°C) at approx. 20-60% of the nominal capacity. Every six months of storage, charge the battery pack as normal.

Intended use

The battery pack 9HB180LT (5) is used as the power source for RUPES HSE73 - HSR73 - HSS73.

Battery pack specifications:

Model	Chemistry	Voltage	Capacity	Energy	Weight
9HB180LT	Lithium Ion	18V	2.5 Ah	45 Wh	0.360±0.005 kg

 **WARNING: for other technical data refer to the label of Battery pack 9HB180LT.**

 **WARNING: to reduce the risk of injury or explosion, never burn or incinerate a tool's battery pack even if it is damaged, dead or completely discharged. When burned, toxic fumes and materials are created.**



ASSEMBLE AND DISASSEMBLE BATTERY PACK

 **AWARNING: Before (dis)assembling the tool assure that the speed regulation Knob (2) is in OFF position.**

In order to assemble the battery pack, push the clip and insert the battery pack in the tool till it is fixed.

In order to disassemble push the clip and extract the battery from the tool.

CHARGE THE BATTERY PACK

  **WARNING: For your personal safety, READ and UNDERSTAND the instruction manual of charging station 9HC180LT before using.**

 **WARNING: Charge Rupes 18V Li-ION Battery pack 9HB180LT only in the Rupes 18V Li-ION Battery Charger 9HC180LT. Other types of batteries may cause personal injury and damage. This tool's battery pack and charger are not compatible with NiCd or NiMH systems.**

The battery pack(s) contained in the kit shall be charged before use. The provided battery is charged <30%.

In order to charge, connect the Li-Ion battery with a charging station 9HC180LT till the charging is completed.

Charge your battery tool when convenient for you and your job.

The Rupes Battery pack does not develop "memory" when charged after only a partial discharge.

It is not necessary to run down the battery tool pack before placing it on the charger.

Use the led Battery pack 9HB180LT level indication to determine when to charge the Rupes Battery pack.

POWER SUPPLY (PROVIDED OR OPTIONAL)



WARNING: For your personal safety, READ and UNDERSTAND the instruction manual of Power Supply 9HP180LT before using.



WARNING: Voltage and power frequency must match the data displayed on the identification plate of the 9HP180LT power supply. Make sure that tool is switched off before plug is connected.

ASSEMBLE AND DISASSEMBLE POWER SUPPLY



WARNING: Before (dis)assembling the tool assure that the speed regulation Knob (2) is in OFF position.

In order to assemble the power supply, push the clip and insert the power supply in the tool till it is fixed.
In order to disassemble, push the clip and extract the power supply from the tool.

STARTING AND STOPPING

Starting: Rotate the speed regulation knob (2) and set up the speed; Now the tool can be started by pressing the START/STOP switch lever (3). The RPM can be adjusted by rotating the speed regulator knob (2).

Stopping: Release the lever for stop the tool; Rotate the speed regulation knob until position 0 and the tool will have turned off.



WARNING: If a case of unusual vibration is present after a start of the tool, switch-off the tool immediately and eliminate the fault.



WARNING: To reduce the risk of injury, turn the knob until OFF position (position 0) after any use.

ELECTRONIC CONTROLLER

Soft start

The soft start is electronically controlled. The soft start guarantees the motor and battery protection and reduces the risk of injury for the operator.

Speed control

The speed of the tool can be changed by rotating the speed regulation knob (2) to the desired setting.
The speed regulation knob can be set speed for any speed between 7000 and 11000 RPM.

Tool Protections

The electronic protection protects the tool from different events that can damage the tool and create a risk of injury for the operator. It also guarantees a longer life.

NOTICE: in a case of overcurrent or overheating caused by repeated starts or excessive overloads, the protection limits the tool power consumption and reduce RPM. If the condition continues, the electronic protection turns off the tool.

ACCESSORIES ASSEMBLY AND DISASSEMBLY



WARNING: Before (dis)assembling the tool assure that the speed regulation knob (2) is in OFF position (0 position).

NOTICE: For have the optimal tool performance use only original accessories and consumables.

Sanding Pad

- Place the sanding pad (9) in the center;
- Tighten the sanding pad fixing screw (7). (Fig. 1)
- For disassembly: Unscrew pad's mounting screws (7).

NOTICE: Fitting non-original or incorrect sized backing pads may cause excessive vibration of the tool.

Abrasive Paper

- Used abrasive paper can be removed by simply tearing them off;
- Apply the new abrasive paper by pressing the same on the sanding pad (9), and making sure that the holes on the paper coincide with suction holes of the pad.

NOTICE: Only Velcro abrasive paper with dust extraction holes is allowed.

DUST EXTRACTION



WARNING: Dust can be hazardous to health. Always work with a dust extractor. Always read applicable nation regulations before extracting hazardous dust.

INTEGRATED EXTRACTION

- To guarantee optimal extraction of the powder empty the conical filter (8) in time, accurately cleaning the filter holder (8a) and regularly cleaning the cartridge (8b);
- During works on the vertical surfaces, position the machine so the conical filter is turned downwards.
- Conical filter assembly: position the conical filter (8) on the extractor connector (4). Push the conical filter until it stops. (Fig. 2)
- Conical filter filling testing: the filling status of the conical filter is easily controlled using the transparent filter holder (8.a).
- Conical filter cleaning: to empty the conical filter, remove it from the extractor connector;
- Release the cartridge (8b) and release it from the filter holder;
- Empty the filter holder;
- Clean the cartridge plates with a soft brush.

EXTERNAL EXTRACTION

- During vertical surface works position the machine in such a way the extractor tube is turned downwards.
- Assembly: insert an extractor tube on the extractor connector (4) (Fig. 2);
- Connect the extractor tube to an adequate vacuum system.

NOISE EMISSION VALUES

Noise emission values determined according to EN 62841-2-4:

HSE73 - HSR73 - HSS73

SOUND PRESSURE LEVEL	dB(A)	67.0
SOUND POWER LEVEL	dB(A)	78.0
UNCERTAINTY (K)	dB	3.0

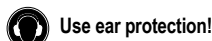

VIBRATION EMISSION VALUES

Vibration total values a_h (triax vector sum) and uncertainty K determined according to EN 62841-2-4:

HSE73 - HSR73 - HSS73

3 AXIS VIBRATION LEVEL (a_h)	m/s ²	2.5
UNCERTAINTY (K)	m/s ²	1.2

Displayed emission values are comparative and are to be employed for a provisional assessment of the operator's risk exposure during the work period. Appropriate evaluation of work period must also include tool's idle and stop periods. These emission values represent the tool's main applications. If the tool is used for other applications, with other accessories, or if it does not undergo regular maintenance, emission values can significantly increase during operations.

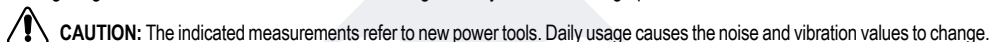

MAINTENANCE AND SERVICING



CLEANING

At the end of each work session, or when required, remove any dust from the body of the tool using a soft cloth, paying particular attention to the motor ventilation slots.

No other maintenance operations must be undertaken by the user.

REPAIRS

Maintenance and cleaning of the inner parts like ball bearings, gears etc. or others, must be carried out only by an authorized customer service workshop.

DISPOSAL (WEEE DIRECTIVE)

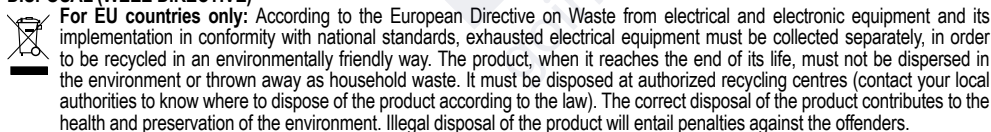

EU DECLARATION OF CONFORMITY

We declare under our responsibility that the represented tools are in conformity with the directives:

2006/42/EC, 2014/30/EU, 2011/65/EU.

The tests have been carried out in accordance with the following standards:

EN 62841-1:2015 + AC:2015;

EN 62841-2-4:2014 + AC:2015;

EN IEC 55014-1:2021;

EN IEC 55014-2:2021;

EN IEC 61000-3-2:2019 + A1:2021;

EN 61000-3-3:2013 + A1:2019 + A2:2021;

EN IEC 63000:2018.

Vermezzo con Zelo (MI), 03/10/2022

Technical file at:
RUPES S.p.A.
Via Marconi, 3/A - Loc. Vermezzo
20071 - VERMEZZO CON ZELO (MI) - Italy

RUPES[®] S.p.A. a socio unico

G. Valentini
The President



RUPES S.p.A. a socio unico

Via Marconi, 3/A - Loc. Vermezzo
20071 Vermezzo con Zelo (MI) - Italy
Tel. +39 02 946941 - Fax +39 02 94941040
info_rupes@rupes.it - www.rupes.com

Uff. Vendite e assistenza clienti:
tel. + 39 02 94694312

Sede legale:
Viale Bianca Maria, 13 - 20122 MILANO - ITALY