

RUPES®



Via Marconi, 3/A - Loc. Vermezzo
20071 VERMEZZO CON ZELO (MI) - Italy
Tel. +39 02 946941 - Fax +39 02 94941040
e-mail: info_rupes@rupes.it - web: http://www.rupes.com

LHR21ES - LHR15ES

- 4 - (IT) Lucidatrice
- 6 - (EN) Polisher
- 8 - (FR) Polissoir
- 10 - (DE) Polierer
- 12 - (ES) Pulidora
- 14 - (PT) Polidora
- 16 - (NL) Polijstmachine
- 19 - (FI) Kiillotuskone
- 21 - (DA) Poleremaskine
- 23 - (SV) Polermaskin
- 25 - (RU) Полировальная машина
- 28 - (PL) Polerka
- 31 - (EL) Στιλβωτής
- 34 - (BG) Полираща машина
- 37 - (CS) Leštička
- 39 - (ET) Poleerija
- 41 - (HI) पॉलिशर
- 43 - (HU) Polírozó
- 45 - (LV) Pulētājs
- 47 - (LT) Poliravimo mašina
- 49 - (RO) Mașină de lustruit
- 51 - (SL) Polirnik
- 53 - (SK) Leštička
- 55 - (TR) Polisaj makinesi
- 57 - (AR) عدة التلميع
- 59 - (ZH) 抛光机
- 61 - (JA) ポリッシャー

ISTRUZIONI ORIGINALI PER L'USO

TRANSLATION OF ORIGINAL OPERATING INSTRUCTIONS

TRADUCTION DES INSTRUCTIONS DE FONCTIONNEMENT ORIGINALES

ÜBERSETZUNG DER ORIGINAL BETRIEBSANLEITUNG

TRADUCCIÓN DEL MANUAL DE INSTRUCCIONES ORIGINAL

TRADUÇÃO DAS INSTRUÇÕES DE OPERAÇÃO ORIGINAIS

VERTALING VAN ORIGINELE GEBRUIKSAANWIJZING

ALKUPERÄISTEN KÄYTTÖOHJEIDEN KÄÄNNÖS

OVERSÆTTELSE AF ORIGINAL BETJENINGSINSTRUKTIONER

ÖVERSÄTTNING AV ORIGINAL DRIFTSINSTRUKTIONER

ПЕРЕВОД ОРИГИНАЛЬНОЙ ИНСТРУКЦИИ ПО ЭКСПЛУАТАЦИИ

TŁUMACZENIE ORYGINALNYCH INSTRUKCJI OBSŁUGI

ΜΕΤΑΦΡΑΣΗ ΠΡΩΤΟΤΥΠΩΝ ΟΔΗΓΙΩΝ ΛΕΙΤΟΥΡΓΙΑΣ

ПРЕВОД НА ОРИГИНАЛНИ ИНСТРУКЦИИ ЗА ЕКСПЛОАТАЦИЯ

PŘEKLAD ORIGINÁLNÍHO NÁVODU K OBSLUZE

ORIGINAALKASUTUSJUHENDI TÕLGE

इस्तेमाल के लिए मूल निर्देशों का अनुवाद

AZ EREDETI HASZNÁLATI UTASÍTÁS FORDÍTÁSA

ORIGINĀLĀS LIETOŠANAS INSTRUKCIJAS TULKOJUMS

ORIGINALŲ NAUDOJIMO INSTRUKCIJŲ VERTIMAS

TRADUCEREA INSTRUCȚIUNILOR ORIGINALE DE OPERARE

PREVOD IZVIRNIH NAVODIL ZA DELOVANJE

PREKLAD ORIGINÁLNEHO NÁVODU NA OBSLUHU

ORIJINAL KULLANIM TALIMATLARININ TERCÜMESİ

توليد اللى غشيتا تاميلعت تم جرت

操作说明书原件翻译

元の操作手順の翻訳

LHR 15ES

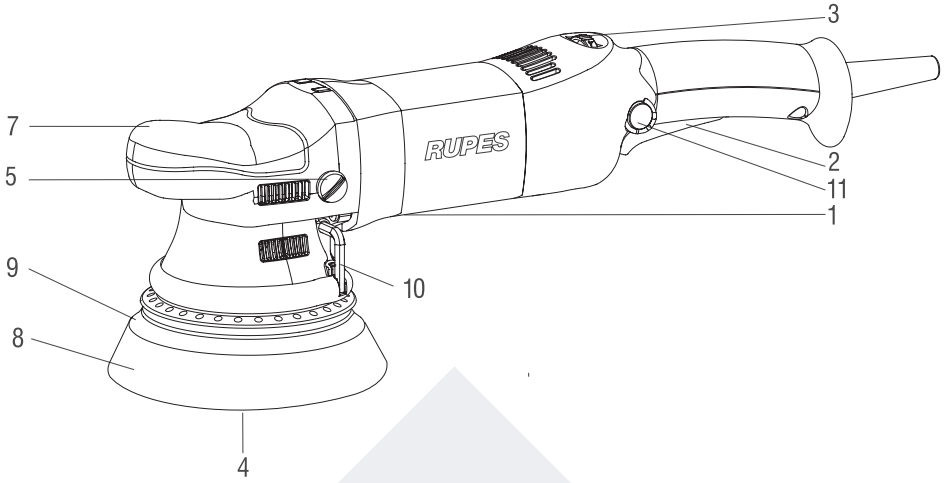

LHR 21ES

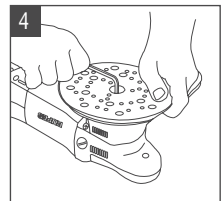
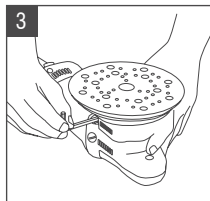
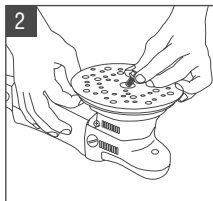
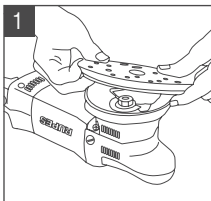
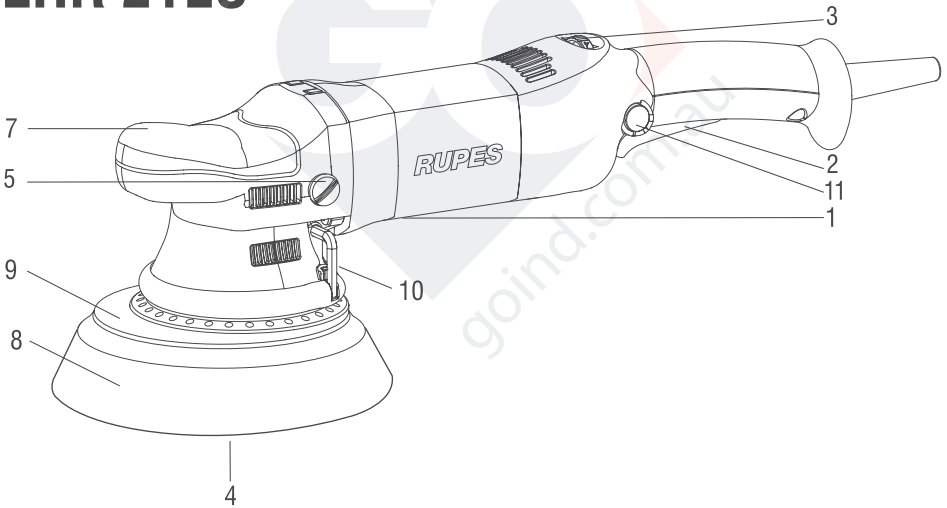



TYPE	LHR 21ES	LHR 15ES
Ø POLISHING FOAM mm	180	150
Ø BACKING PAD mm	150	125
Ø ORBIT mm	21	15
POWER	500	500
R.P.M.	2000 ÷ 4200	2000 ÷ 5000
WEIGHT	2,60	2,50
ELECTRONIC SPEED CONTROL	•	•
INSULATION CLASS	II	II

The values shown are based on a nominal voltage of 230V/50Hz. In the case of voltages and frequencies of different power values may vary. Refer to the label technical specifications to the nominal values of the tool.

PICTOGRAPH

 Read the following instruction first before operating the product.

 Important safety indications

 Use personal protective equipment.

 Double insulated tool.
INSULATION CLASS II

 CE compliant

WARNINGS

 **WARNING! Read all safety warnings, instructions, illustrations and specifications provided with this power tool.** Failure to follow all instructions listed below may result in electric shock, fire and/or serious injury. **Save all warnings and instructions for future reference.** The safety and accident prevention instructions are reported in the “SAFETY INSTRUCTION” booklet which is an integral part of these documents. This operating instructions manual indicates the additional information required for the specific use of the tool.

CORRECT USAGE

This tool is designed to be used as a polisher.

This tool is not intended to be used for smoothing, metal brushing and cutting operations. The use of this tool for unintended applications may cause hazards and injuries to people.

The tool must be used with accessories that have been specifically designed or recommended by the manufacturer. The fixing of the accessory to the tool does not guarantee a safe operation.

The rated speed of the accessories must be at least equivalent to the maximum speed specified on the tool. Using the accessories at speeds above the rated one, may cause them to break or be projected into the air. **The external diameter and thickness of the accessories must match the specifications of the tool.** Accessories with incorrect dimensions cannot be adequately protected or controlled.

The configuration of accessories must match the tool. The use of accessories that cannot be perfectly fitted on the tool may result in imbalance, excessive vibrations and in the impossibility of controlling the tool.

Do not use damaged accessories. Before use, inspect all the accessories. Inspect the supporting pads and verify there are no cracks, tears or excessive wear. If the tool or accessory has fallen, verify that it is not damaged or install a new accessory. After inspecting or installing an accessory, test the operation of the tool at maximum speed and without load for one minute, keeping at a safety distance. If the accessories are damaged, they will break during this test.

STARTING UP

 Voltage and power frequency must match the data displayed on the identification plate (1). Make sure that tool is switched off before plug is connected.

TOOL ASSEMBLY

Position the cap (7) on the gearbox such that the holes for mounting the screws (5) are aligned with those on the gearbox.

ACCESSORIES ASSEMBLY

BACKING PAD (Pic 1 to Pic 4)

- Place the disc pad (9) in the centre;
- slightly turn the disc pad (9) until it is fixed to the screw;
- tighten the disc pad fixing screw using the supplied disc pad Allen wrench (10). Do not tighten the disc pad if it is in the wrong position.
- lubricate the rubber shroud (11) with non-silicone based products.
- ordinary maintenance: it 's necessary to periodically check the correct tightening of the screw (4) of the backing pad using the wrench supplied (10)

POLISHING FOAM

Apply pressure on polishing pad to join pad to plate (8).

START AND STOPPING

- Starting: push the lever of the switch (2) towards the body of the tool; if the tool is to be locked in the ON position, press button (11) at the same time and keep it pressed while releasing lever (2), thus locking the switch.
- Stopping: release the lever of the switch or, if locked in position, push the lever to release the lock button.

 The tool continues to rotate after it is turned off.

 Do not empty the tool with the polishing pad still mounted. In this way, the polishing pad may be subject to lacerations

SELECTING RPM

The rpm can be adjusted by rotating the wheel (3). The choice of speed depends on the characteristics of the abrasive disc and the material to be worked.

ACCESSORIES DISASSEMBLY

BACKING PAD

Unscrew pad's (4-9) mounting screw using the wrench (10).

POLISHING FOAM

Remove the polishing foam used and apply the new one with pressing on the backing pad.

ALLOWED ACCESSORIES

LHR 21ES: polishing foam Ø 180 mm for backing pad Ø 150 mm.

LHR 15ES: polishing foam Ø 150 mm for backing pad Ø 125 mm.

NOISE EMISSION VALUES

Noise emission values determined according to **EN 62841-2-4**:

		LHR 21ES	LHR 15ES
SOUND PRESSURE LEVEL	dB(A)	77	77
SOUND POWER LEVEL	dB(A)	88	88
UNCERTAINTY (K)	[dB]	3	3

 Use ear protection!

VIBRATION EMISSION VALUES

Vibration total values a_h (triax vector sum) and uncertainty K determined according to **EN 62841-2-4**:

		LHR 21ES	LHR 15ES
3 AXIS VIBRATION LEVEL	m/s^2	2.7	2.7
UNCERTAINTY (K)	m/s^2	1.7	1.5

Displayed emission values are comparative and are to be employed for a provisional assessment of the operator's risk exposure during the work period. Appropriate evaluation of work period must also include tool's idle and stop periods. These emission values represent the tool's main applications. If the tool is used for other applications, with other accessories, or if it does not undergo regular maintenance, emission values can significantly increase during operations.

 **Danger!** The indicated measurements refer to new power tools. Daily usage causes the noise and vibration values to change.

MAINTENANCE

All maintenance operations are carried out with the power supply disconnected. At the end of each work session, or when required, remove any dust from the body of the tool using a jet of compressed air, paying particular attention to the motor ventilation slots.

No other maintenance operations must be undertaken by the user.

Maintenance and cleaning of the inner parts, like brushes, ball bearings, gears etc. or others, must be carried out only by an authorized customer-service workshop.

DISPOSAL (WEEE DIRECTIVE)

 **For EU countries only:** According to the European Directive on Waste from electrical and electronic equipment and its implementation in conformity with national standards, exhausted electrical equipment must be collected separately, in order to be recycled in an environmentally friendly way. The product, when it reaches the end of its life, must not be dispersed in the environment or thrown away as household waste. It must be disposed at authorized recycling centres (contact your local authorities to know where to dispose of the product according to the law). The correct disposal of the product contributes to the health and preservation of the environment.

Illegal disposal of the product will entail penalties against the offenders.

EU DECLARATION OF CONFORMITY

We declare on our responsibility that the represented tool is in conformity with the directives:

2006/42/EC, 2014/30/EU, 2011/65/EU.

The tests have been carried out in accordance with standard:

EN 62841-1:2015 + AC:2015

EN 62841-2-4:2014 + AC:2015

EN 62233:2008 + AC:2008

EN IEC 55014-1:2021

EN IEC 61000-3-2:2019 + A1:2021

EN 61000-3-3:2013 + A1:2019 + A2:2021

EN IEC 55014-2:2021

EN IEC 63000:2018

Vermezzo con Zelo (MI), 18/04/2023

RUPES S.p.A. a socio unico
THE PRESIDENT
G. Valentini

Technical file at:

RUPES S.p.A. a socio unico
Via Marconi, 3/A - Loc. Vermezzo
20071 VERMEZZO CON ZELO (MI) - Italy



RUPES S.p.A. a socio unico
Via Marconi, 3/A - Loc. Vermezzo
20071 VERMEZZO CON ZELO (Mi) - Italy
Tel. +39 02 946941
Fax +39 02 94941040

Uff. Vendite e assistena clienti:
Tel. +39 02 94694312

e-mail: info_rupes@rupes.it
web: <http://www.rupes.com>

Sede legale:
Viale Bianca Maria, 13 - 20122 Milano - Italy