

Owners Manual

Product Code: 1032T

**MADE FOR THE
TRADE**

TQ TRADEQUIP
the trusted brand in equipment

AIR CONDITIONER



Specifications:

- Cooling Capacity: 4.5KW / 15300Btu
- Power Unit: 240V 50Hz
- Rated Power: 2000W
- Rated Current: 9.0A
- Max. Air Flow: 800m³ per hour
- Noise Level: 60dB(A)
- Operating Temperature: 18° - 45°C
- Suction Pressure: 2.5Mpa (Max.)
- Discharge Pressure: 4.5Mpa (Max.)
- Speed Control: 2-speed
- Refrigerant: R410/800g
- Condensation Tank Capacity: 8 Litres
- Castor Wheels: 75mm Dia (2 with brakes)
- Dimension: 1035(H) x 520(W) x 480(D)
- Nett Weight 70kg
- Carton 1of2: 1110 x 610 x 570mm
- Carton 2of2: 370 x 350 x 260mm
- Gross Weight 78kg

About the TradeQuip brand

The 'TradeQuip' brand of workshop equipment, is designed for use in a demanding workshop environment by professional users. With proven and trusted "**Made for the Trade**" reliability, 'TradeQuip' branded products offer the very best in performance for an affordable price. All backed by a 1year trade guarantee across 1,000+ distributors Australia wide.

TQ TRADEQUIP
the trusted brand in equipment

TQPro
Trusted by serious professionals

BORUM
INDUSTRIAL WORKSHOP EQUIPMENT

WARNING**IMPORTANT: READ ALL INSTRUCTIONS BEFORE USE** **WARNING**

The instructions and warnings contained in this manual should be read and understood before using or operating this equipment. Do not allow anyone to use or operate this equipment until they have read this manual and have developed a thorough understanding of how this equipment works. Failure to observe any of the instructions contained in the manual could result in severe personal injury to the user or bystanders, or cause damage to the equipment and property. Keep this manual in a convenient and safe place for future reference.

Whilst every effort has been made to ensure accuracy of information contained in this manual, the TQB Brands Pty Ltd policy of continuous improvement determines the right to make modifications without prior warning.

CONTENT

WARNING.....	2
CONTENT.....	2
STANDARD OPERATING PROCEDURE	3
OPERATION, PREVENTITIVE MAINTENANCE.....	4
TROUBLESHOOTING.....	7
PARTS DIAGRAM & PARTS LIST.....	8
WARRANTY	9

STANDARD OPERATING PROCEDURE

DO NOT use this equipment unless you have been trained and assessed to a competent level in its safe use and operation, and have been given permission to use this



DO NOT tilt the unit



DO NOT operate the unit with wet or damp hands

PRE-OPERATIONAL SAFETY CHECKS

- Do not use this Air Conditioner in areas that use or store volatile substances (gasoline, kerosene, liquefied gas and other volatile liquids; magnesium, aluminium, lead and other volatile dust and/or vapours) to avoid possible ignition, explosion or fire.
- Servicing must be carried out by a qualified service technician. Use only TradeQuip identical replacement parts. Use of any other parts will void the warranty. Ensure the Air Conditioner is disconnected from power before servicing.
- Use the right product for the job. There are certain applications for which the Air Conditioner was designed. Do not modify the Air Conditioner and do not use the Air Conditioner for a purpose for which it was not intended.
- Always disconnect the Air Conditioner when moving it from one location to another.
- Transport and store the unit in an upright position only. Leave unit in an upright position for at least 3 hours before first use.
- Always place the unit on an even, level surface.
- Ensure the unit is connected to a grounded power supply of the correct rating / capacity.
- The unit will cool when the room temperature is between 18°C (64.4°F) ~ 45°C(113°F) depending on the thermostat setting.
- DO NOT use this unit for functions other than those described in this instruction manual.
- DO NOT tilt the unit. Only use in the upright position on an even, flat surface. Unit must be positioned at least 600mm from the nearest object in any direction
- Ensure 240V mains power supply.
- Use within temperature range of 18°C ~45°C
- This Air Conditioner is intended for indoor use only.
- DO NOT cover or obstruct the unit's inlet and outlet grills or ducting.
- DO NOT use the unit in areas where it will be exposed to rain or water.
- NEVER unplug the unit while it is operating.
- DO NOT place any foreign objects on the unit.
- DO NOT operate the unit with wet or damp hands.
- DO NOT allow chemical substances to come into contact with the unit.
- DO NOT operate the unit in the presence of flammable substances or vapours such as alcohols, pesticides, gasoline, etc. DO NOT use the plug to start and to stop the unit. Always use the control panel to start and to stop the unit.
- Always turn off the unit when it is not in use and unplug the power plug from the electrical outlet.
- Always turn the unit off and unplug the main power plug from the electrical outlet before cleaning, moving or performing maintenance.
- AVOID the use of adaptor plugs or extension cords. If it is necessary to use an extension cord or an adaptor plug to operate the unit, ensure that they are correctly rated for the application. Consult a local qualified electrician and all local electrical codes to ensure proper setup. Any extension cord used with this device must be rated for a minimum of 30A.
- DO NOT unplug the unit by pulling on the electrical cord. Keep electrical cord away from heat sources and always completely unroll the cord to avoid overheating. If the power cord becomes damaged, a qualified service agent, qualified electrician, or similarly qualified person must replace it, in order to avoid a hazard or shock.
- The filters must be used with the product at all times. When the filters are removed for cleaning, always ensure that the unit has been turned off and unplugged from the electrical outlet.
- DO NOT operate the unit with a damaged power cord or plug, after it malfunctions, has been dropped or damaged.
- Regularly clean the filters to maintain efficiency. If the filters are not cleaned regularly, the unit's output performance and efficiency will decline and energy consumption will increase.
- Stop operation immediately if abnormal noise or odour is noticed. Contact a local service centre.
- This appliance is not to be used by children or persons with reduced physical, sensory or mental capabilities, or lack of experience and knowledge, unless they have been given supervision or instruction.
- This appliance must be installed in accordance with state and/or national wiring regulations.
- If the power supply cord is damaged, it must be replaced by the manufacturer, its service agent or similarly qualified electrician in order to avoid a hazard.

INTENDED USE

This appliance is intended for air conditioning industrial or trade workshop/office environments. It is not suitable for any other purpose (such as drying clothes, cooling food, etc.) This product is an Industrial Product and not suitable for household use.

OPERATION, PREVENTIVE MAINTENANCE

1. FEATURES

TradeQuip Portable Industrial Air Conditioners are designed for economical spot cooling in workshops, service rooms, warehouses and offices especially where other electrical equipment creates a heat load. TradeQuip Portable Industrial Air Conditioners are completely self-contained and housed within an insulated cabinet. The unit's exterior is constructed of galvanized steel and protected with a tough powder-coated, polyester finish. All models are equipped standard with heavy-duty castors for easy portability. TradeQuip Portable Industrial Air Conditioners bring in air from an outside source to cool its condenser, cycling hot air to an outside source. This provides a fresh cool air room temperature with high efficiency. Just wheel it in, plug it in and it goes to work immediately, giving high cooling capacity to help wherever and at whatever point you require it. Like all air conditioning systems, TradeQuip Portable Industrial Air Conditioners extract heat which must be expelled outdoors and the TradeQuip units do this through an exhaust tube which connects from the appliance to a window opening or doorway.

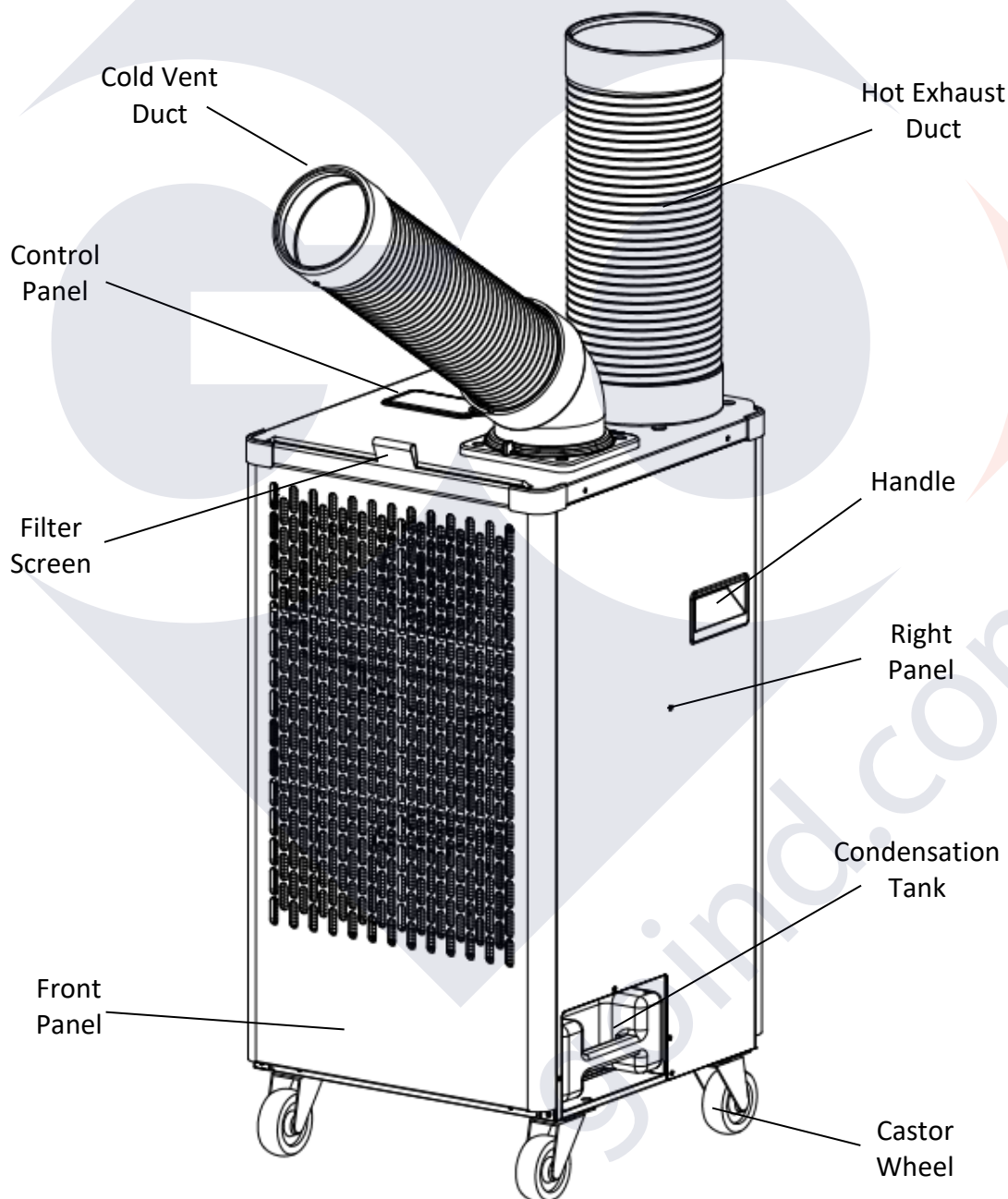

2. BEFORE USE

Prior to each use conduct a visual inspection by checking for abnormal conditions, such as cracked joins and damaged, loose, or missing parts. If the supply cord is damaged, it must be replaced by the manufacturer, service agent or similarly qualified persons in order to avoid a hazard.

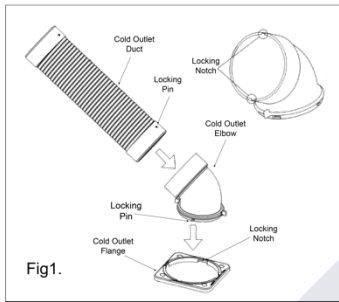

Installation of Elbow

Insert the elbow by aligning the notches in the detachable elbow base on the machine, insert and rotate anti clockwise until it locks into place (Fig1).

Installation of Cold Vent Duct

Insert the cold vent duct pipe by aligning the notches into the detachable elbow, insert and rotate left until it locks in place (Fig1).

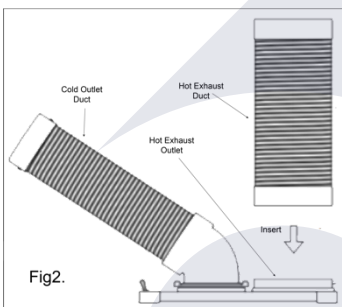

Installation of Hot Exhaust Duct

Insert the hot exhaust duct pipe into the heat vent. Do not install it in place to guarantee stable and firm exhaust pipe (Fig.2).

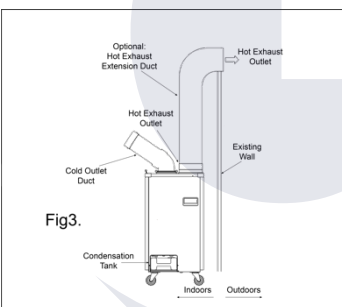

Installation of Extended Hot Exhaust Ducting to Outdoors – (Optional)

Hot Exhaust discharge air can be removed from the airconditioned space with flexible duct. Prior to installation an outlet aperture in the wall is required.

To connect an extended hot exhaust duct detach the joint of the exhaust outlet and secure the ends with a suitable fixing tape. The outdoor heat extraction duct must be water proof and protected from external debris falling into the exhaust duct (point pipe downwards).

3. OPERATION

1. Unlock the castors wheels and push the unit using the side handles to a flat, level surface and set the castor brakes to the locked position.
2. Check the prongs and surface of the power cord plug for dust/dirt. If dust and/or dirt are present, wipe off with a clean, dry cloth.
3. Check the power cord, plug and prongs for damage or excess play.
4. If any damage or excess play is found, contact a qualified repair technician or a qualified electrician to perform replacement or repair of the power cord, plug or prongs. Rotate the dial to or and the compressor immediately launches refrigeration.
5. Start the fan by rotating the control switch to Low and/or increase the airflow by rotating to High .
6. When the dial is rotated to "0" the appliance is switched off.
7. When the appliance is running, ensure the filter screen and the cold air ducting are 300mm minimum from the wall or other obstacles, and the hot exhaust pipe is 900mm minimum from the ceiling or other obstacles.(Fig12)
8. Ensure the appliance is on a level, solid surface.
9. Ensure the filter screen and air outlets are clear of obstacles.
10. Ensure the hot air exhaust pipe is not pointing towards poor heat resistant items.



WARNING – Always turn the machine off before moving – Wait 3minutes before restarting the machine.

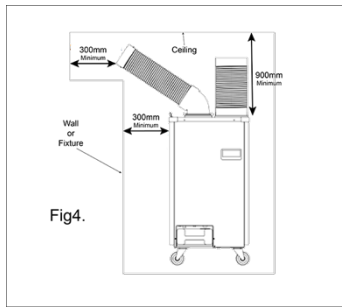

Fig4.

Minimum Clearance

When the appliance is running, ensure the filter screen and the cold air ducting are 300mm minimum from the wall or other obstacles, and the hot exhaust pipe is 900mm minimum from the ceiling or other obstacles.

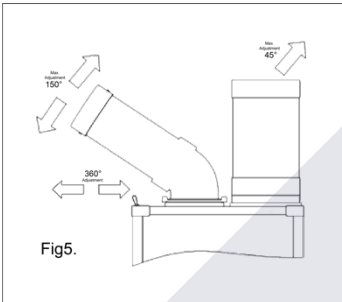

Fig5.

Adjustment Air Range

The cold air duct can rotate left or right to 360degrees (hot air exhaust duct is installed)

The cold air duct may be moved up or down to 150degrees

The range of adjustment angle for the hot air exhaust duct is 45degrees



WARNING -Adjust the cold air duct prior to use and adjust the air out direction of the hot exhaust duct later. When adjusting the flow angle of the cold air duct, grip the elbow for adjustment – do not hold on to the cold air duct directly.



Fig6.

Condensation Tank

A 5Litre polyethylene condensation tank in the lower-front compartment of the unit collects evaporator-coil condensation moisture. When full, simply remove, drain, replace, and restart. Do not move the machine if the condensation tank is full of water.

To empty the water in the condensation tank, ensure the end face on the tank handle is parallel. Rotate the control switch to 0. Empty the water in a resourceful manner and reinstall the condensation tank before restarting Air Conditioner.

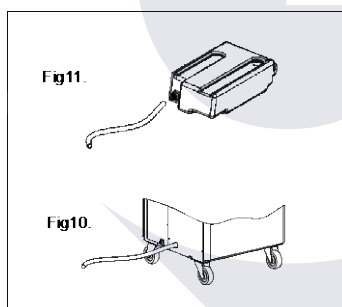

Fig11.

Fig10.

Condensation water may be discharged directly from the Air Conditioner drain pipe.

Remove the water tank and empty, push the optional drain pipe on to the appliance outlet inside the tank recess. Then locate the drain pipe through the round hole in the corresponding side plate. Ensure the end of the pipe is below the Air Conditioner.

Compressor Overload/Overheat Protection

The compressor overload protector will be activated to cut the power of the compressor to "Off" in the event of overly high or low voltage and/or overly high temperatures.

When the overload protector is activated, the machine will only blow non-refrigerated air.

Contact a qualified service technician if the overload protector is activated frequently.

4. MAINTENANCE

Disconnect power prior to any maintenance

Inspect the general condition of the Air Conditioner checking:

- for loose hardware
- cracked, bent, or broken parts, and
- any other condition that may affect the Air Conditioners safe operation

Filter Screen

Clean the filter screen regularly using a vacuum cleaner to remove dust and dirt. When required the filter screen can be cleaned with a cloth and luke warm water. Do not use chemicals. Leave to dry in a shaded area before reinstalling.

NOTE: For effective cooling clean the filter at least every 2 weeks.

5. STORAGE

This Air Conditioner should always be stored in a dry location on a level surface in an upright position.

When you stop using this Air Conditioner, you should clean the filter and keep it in a dry place, be careful not to damage the Air Conditioner or filter.

Shut Down

Prior to shut down ensure the water in the condensation tank is empty. Always store the Air Conditioner in the upright position.

6. SERVICE & REPAIR

Any Air Conditioner found damaged in any way, or found to be worn or operates abnormally should be removed from service until repaired by an authorised service agent. Owners and / or operators should be aware that repair of this product may require specialised equipment and knowledge. Only authorised parts, labels and decals shall be used on this equipment. Annual inspection of the Air Conditioner is recommended and can be made by an authorised repair facility to ensure that your equipment is in optimum condition and that the equipment has the correct decals and safety labels specified by the manufacturer.

TROUBLESHOOTING

Problem	Cause	Solution
Out-of-Operation	<ul style="list-style-type: none"> Power Cable loose Fuse is burnt 	<ul style="list-style-type: none"> Insert Power Cable into power supply Repair or replace fuse
Out-of-Operation	<ul style="list-style-type: none"> Heat exchange surface is blocked Hot exhaust blower fails External temperature is too high Compressor capacitor is damaged Refrigerating system pipeline is clogged Overly high or low input voltage Compressor overheat & overload protection fails Compressor motor fails 	<ul style="list-style-type: none"> Clean heat exchange surface Repair or replace hot exhaust blower Unplug the heater and relocate Replace compressor capacitor Replace pipeline system Ensure correct voltage Wait 3 minutes and then restart the heater Repair or replace compressor
Water Leakage	<ul style="list-style-type: none"> Drain pipe opening is clogged Water tank position is not in place Filter screen is dusty Water tank is full 	<ul style="list-style-type: none"> Clean drain pipe Adjust water tank to the correct position Clean filter screen Empty water

PARTS DIAGRAM & PARTS LIST

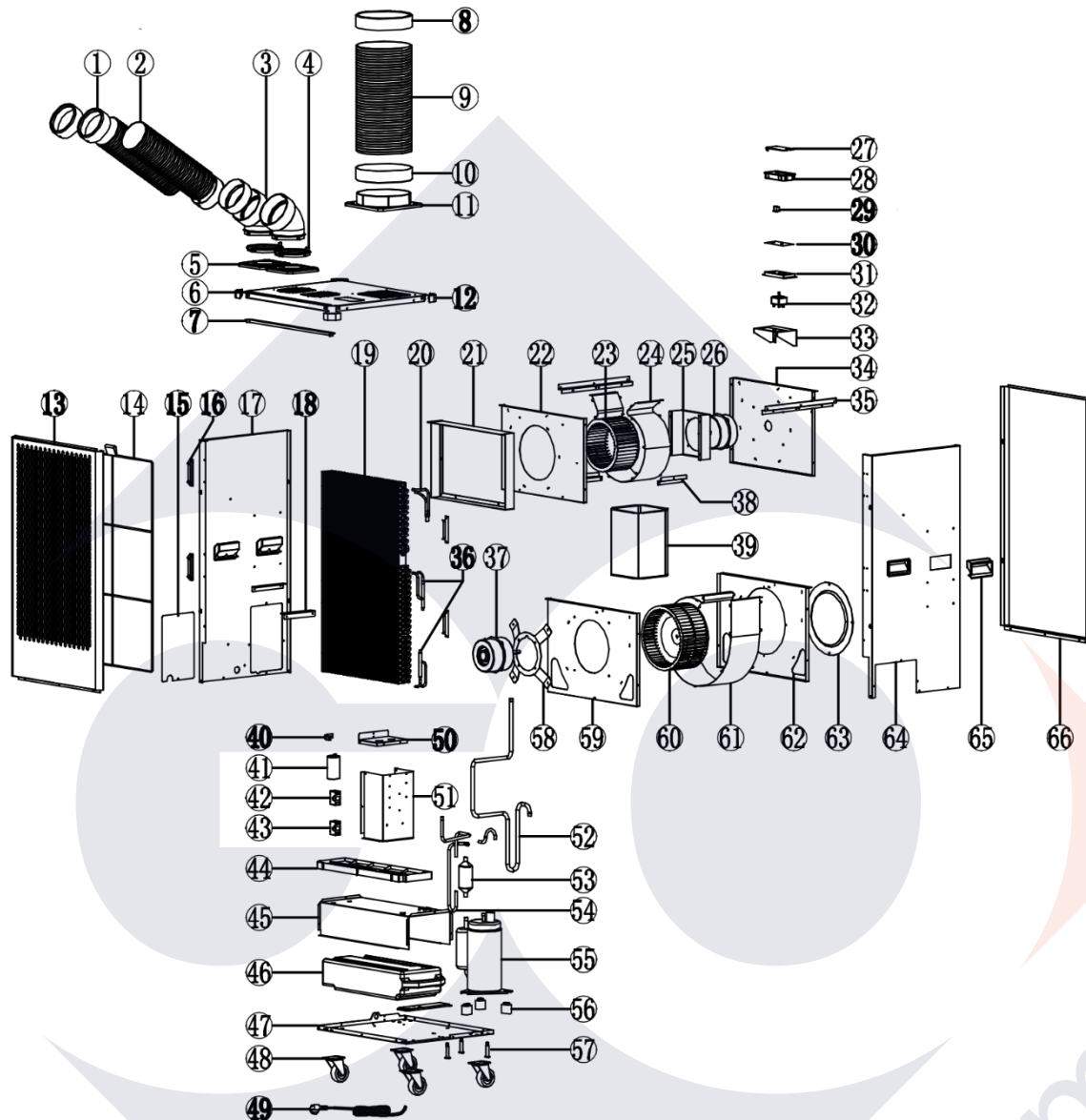

Part #	Description	QTY
1	Connector 1	6
2	Cooling Tube	3
3	Tube 1	3
4	Tube 1 Fix Frame	3
5	Tube 1 Fix Base	3
6	Top Cover	1
7	Top Cover Fix Plate	1
8	Tube Head	2
9	Tube 2	1
10	Tube Head	1
11	Hot Air Ring	1
12	Angle Protection	4
13	Front Shell	1
14	Filter Net	1
15	Control Cover Plate	1
16	Guide Groove	4
17	Left Side Plate	1
18	Side Plate Scaffold	2
19	Heat Exchanger Assy	1
20	Steaming Tube Assy	1
21	Anterior Spiral Case	1
22	Spiral Case Support	1

Part #	Description	QTY
23	Wind Mill 1	1
24	Cold Wind Spiral Case	1
25	Connect Bracket	1
26	Upper motor	1
27	Control Box Cover	1
28	Control Box Frame	1
29	Knob	1
30	Control Panel Label	1
31	Control Box	1
32	Rotate Switch	1
33	Switch Fix Plate	1
34	Spiral Case Bracket	1
35	Volute Connection Plate	5
36	Cold Inlet Pipe Assy	1
37	Lower Motor	1
38	Spiral Case Fixed Frame	2
39	Air Duct Components	1
40	Capacitor Bracket	1
41	Compressor Capacitor	1
42	Motor Capacitor 1	1
43	Motor Capacitor 2	1
44	Condensation Tray	1

Part #	Description	QTY
45	Tank Cover Plate	1
46	Condensation Tank	1
47	Chassis	1
48	Universal Castors	4
49	Power Cord & Plug	1
50	Control Box Cover	1
51	Control Box	1
52	Lower Pressure Tube	1
53	Muffler	1
54	High Pressure Tube	1
55	Compressor	1
56	Compressor Cushion	3
57	Pump Bolt	3
58	Hot Air Motor Support	1
59	Anterior Spiral Case	1
60	Wind Mill 2	1
61	Hot Air Volute shell	1
62	Posterior Spiral Case	1
63	Guide Plate	1
64	Right Side Plate	1
65	Handle	4
66	Back Shell	1

WARRANTY

TradeQuip products have been carefully tested and inspected before shipment and are guaranteed to be free from defective materials and workmanship for a period of 12 months from the date of purchase except where tools are hired out when the guarantee period is ninety days from the date of purchase.

Should this piece of equipment develop any fault, please return the complete tool to your nearest authorised warranty repair agent or contact TQB Brands Pty Ltd Warranty team – warranty@tqbbrands.com.au.

If upon inspection it is found that the fault occurring is due to defective materials or workmanship, repairs will be carried out free of charge. This guarantee does not apply to normal wear and tear, nor does it cover any damage caused by misuse, careless or unsafe handling, alterations, accident, or repairs attempted or made by any personnel other than the authorised TQB Brands Pty Ltd repair agent.

This guarantee applies in lieu of any other guarantee expressed or implied and variations of its terms are not authorised.

Your TQB Brands Pty Ltd guarantee is not effective unless you can produce upon request a dated receipt or invoice to verify your proof of purchase within the 12month period.

Consumer Guarantee

Our goods come with a guarantee that cannot be excluded under the Australian Consumer Law. You are entitled to a replacement or refund for a major failure and compensation for any other reasonably foreseeable loss or damage. You are also entitled to have the goods repaired or replaced if the goods fail to be of acceptable quality and the failure does not amount to a major failure.



All images and illustrations shown are for reference purposes only. All information, specifications and illustrations in this manual are based on the latest information available at the time of publication and are subject to change without notice. The information in this manual is periodically revised to ensure the latest information is included. Download the latest version of this manual and other related technical documentation from www.tqbbrands.com.au