

Owners Manual

Product Code: 1192T

**MADE FOR THE
TRADE**

TQ TRADEQUIP
the trusted brand in equipment

**ENGINE
STAND FOLDING**



Specifications:

- Safe Working Capacity: 900kg
- Operating Height (A) : 800mm Floor to mounting plate centre
- Width(B) : 530mm
- Length (C): 1110mm
- ID between legs (D): 780mm
- OD between legs (E): 930mm
- Lower steel tubing: 60x60mm
- Column tubing: 70x70mm
- Nett Weight: 45kg
- Carton: 910 x 210 x 180mm
- Gross Weight: 43kg

About the TradeQuip brand

The 'TradeQuip' brand of workshop equipment, is designed for use in a demanding workshop environment by professional users. With proven and trusted "Made for the Trade" reliability, 'TradeQuip' branded products offer the very best in performance for an affordable price. All backed by a 1 year trade guarantee across 1,000+ distributors Australia wide.

TQ TRADEQUIP
the trusted brand in equipment

TQpro
Trusted by serious professionals

BORUM
INDUSTRIAL WORKSHOP EQUIPMENT

WARNING

IMPORTANT: READ ALL INSTRUCTIONS BEFORE USE



WARNING

The instructions and warnings contained in this manual should be read and understood before using or operating this equipment. Do not allow anyone to use or operate this equipment until they have read this manual and have developed a thorough understanding of how this equipment works. Failure to observe any of the instructions contained in the manual could result in severe personal injury to the user or bystanders, or cause damage to the equipment and property. Keep this manual in a convenient and safe place for future reference.

Whilst every effort has been made to ensure accuracy of information contained in this manual, the TQB Brands Pty Ltd policy of continuous improvement determines the right to make modifications without prior warning.

CONTENT

WARNING.....	2
CONTENT.....	2
STANDARD OPERATING PROCEDURE	3
ASSEMBLY, OPERATION, PREVENTITIVE MAINTENANCE.....	4
PARTS DIAGRAM.....	5
PARTS LIST.....	6
WARRANTY	6

goind.com.au

STANDARD OPERATING PROCEDURE

DO NOT use this machine unless you have been trained and assessed to a competent level in its safe use and operation, and have been given permission to use this



Safety glasses must be worn when operating this equipment



Long loose hair must be contained when operating this equipment



Safety footwear must be worn when operating this equipment



Close fitting/protective clothing must be worn when operating this equipment



Rings and jewellery must not be worn when operating this equipment

PRE-OPERATIONAL SAFETY CHECKS

Save these instructions. For your safety, read, understand, and follow the information provided.

- Before using the engine stand ensure it is in sound condition, and good working order.
- Replace or repair damaged parts. *Use recommended parts only. Non authorised parts may be dangerous and will invalidate the warranty.*
- Keep the stand clean for best and safest performance.
- Locate the stand in an adequate working area for its function, keep area clean and tidy and free from unrelated materials, and ensure there is adequate lighting.
- Use on a firm, level surface capable of sustaining the engine stand and the load.
- Maintain correct balance and footing. Ensure the floor is not slippery and wear non slip shoes.
- Ensure all non essential persons keep a safe distance whilst the stand is in use.
- Lock mounting plate in position before fixing a load, and ensure the load is centred and securely mounted on the locking plate.
- Always ensure the Stand and the load is stable and within the dimensions of the engine stand.
- To move a loaded stand, push it from the load side, above the two fixed wheels. **DO NOT** move the stand from the castor end and never pull the stand towards yourself. Also ensure surface over which the stand is to travel is strong enough to take the stand load and that it is not cracked, uneven or obstructed.
- All mounting hardware must be tight before using.
- **DO NOT** substitute hardware provided.
- **DO NOT** operate unit if damaged.
- **DO NOT** allow untrained persons to operate the stand.
- **DO NOT** drop load suddenly as resulting shock to unit may cause damage
- **DO NOT** exceed the rated capacity of 900kg.
- **DANGER:** *DO NOT work under an engine mounted on the stand.*

Intended Use

For safe handling and positioning of most 6 and 8 cylinder passenger car engines during dismantling and re-assembly.

ASSEMBLY, OPERATION, PREVENTITIVE MAINTENANCE**1. FEATURES**

The 1192T 900kg Engine Stand accepts a wide variety of engines and transmissions. The head swivels 360° for accessibility to all parts of the engine. It has fully adjustable mounting arms.

Swivel castors provide excellent manoeuvrability. This model also offers a higher than average capacity and features foldable legs for easier storage and transport.

2. ASSEMBLY

1. Attach two 3" swivel castors (#25) and one 3.5" swivel castor (#14) to the base frame (#17) using bolts (#15) and lock washers (#22).
2. Assemble legs (#20) to the base frame (#17) using ringed lock pins (#18) and R pin (#19).
3. Attach the main post (#8) to the cross member between the open channels using bolts (#13), nuts (#4) and flat washers (#3).
4. Attach the top of supports (#12) to the main post using bolt (#9), nut (#11) and flat washer (#10), then connect the end of supports to the base frame using bolts (#16), nuts (#11) and flat washers (#10).
5. Insert the engine mounting plate (#5) through the tube at the top of the main post. Rotate the plate until one of the holes is the inner tube is aligned with a hole in the outer tube and insert the ringed pin (#7).
6. Insert the handle (#6) through the hole in the turning plate tube (which protrudes from the top of the main post).
7. Attach the shifting stands (#1) to the rotating head (#5) using bolts (#2), flat washers (#3) and nuts (#4).
8. To fold up the legs, remove the spring clips from the ring headed pins closest to the fixed wheels and pull out the pins. Fold the legs up. Always retain the legs in the upright position by reinserting the pins through the holes in the frame directly in front of the folded legs. Retain pins with clips.

3. BEFORE USE

Prior to each use conduct a visual inspection by checking for abnormal conditions, such as cracked joints and damaged, loose, or missing parts. Engine dimensions are within the dimensions of the engine stand.

Any Engine Stand which appears to be damaged in any way, badly work, or operating abnormally must be removed from service.

If the Engine Stand is accidentally subjected to an abnormal load or shock, it must be inspected by the manufacturer immediately.

It is recommended that an annual inspection of the Engine Stand be made and that any defective parts, decals, or warning labels be replaced with manufacturer's specified parts.

4. STORAGE

This Engine Stand should always be stored in a dry location on a level surface.

5. MAINTENANCE

Replace or repair damaged parts. Use recommended parts only. Non authorised parts may be dangerous and will invalidate the warranty.

Keep the stand clean for best and safest performance.

It is recommended that an annual inspection of the Engine Stand be made and that any defective parts, decals, or warning labels be replaced with manufacturer's specified parts.

6. SERVICE & REPAIR

Any Engine Stand found damaged in any way, or found to be worn or operates abnormally should be removed from service until repaired by an authorised service agent. Owners and / or operators should be aware that repair of this product may require specialised equipment and knowledge. Only authorised parts, labels and decals shall be used on this equipment. Annual inspection of the engine stand is recommended and can be made by an authorised repair facility to ensure that your equipment is in optimum condition and that the equipment has the correct decals and safety labels specified by the manufacturer.

PARTS DIAGRAM

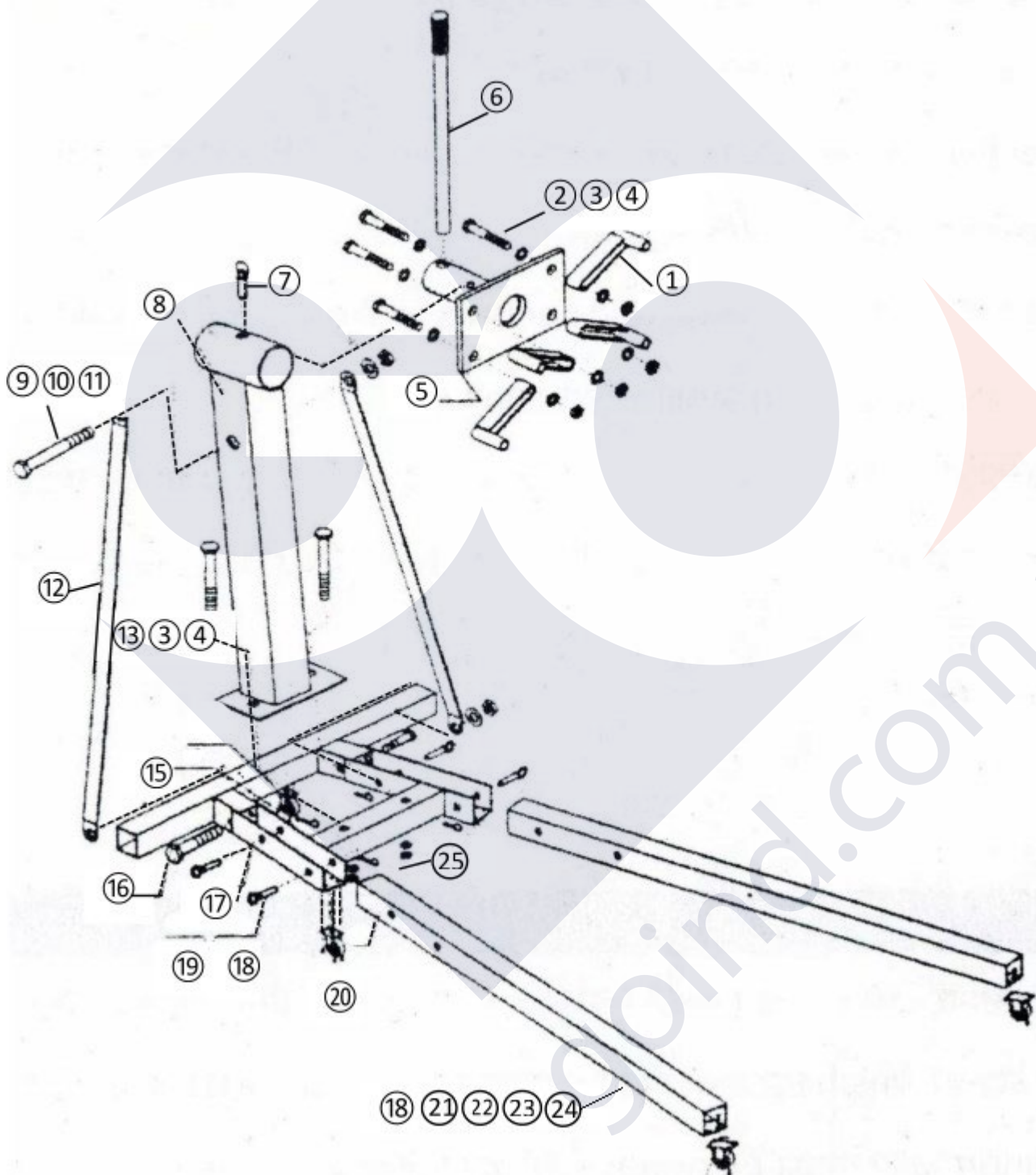

PARTS LIST

Part	Description	Qty	Part	Description	Qty	Part	Description	Qty
1	Shifting Stand	4	10	Flat Washer 16	3	19	"R" Pin	4
2	Bolt M14x65	4	11	Nut M16	3	20	Leg	2
3	Flat Washer 14	10	12	Support	2	21	3.5" Castor	2
4	Nut M14	6	13	Bolt M14x85	2	22	Lock Washer 8	20
5	Turning Plate	1	14	3.5" Swivel Castor	1	23	Bolt M8x20	8
6	Handle	1	15	Bolt M8x12	12	24	Nut M8	8
7	Pin	1	16	Bolt M16x90	2	25	3" Swivel Castor	2
8	Main Post	1	17	Base Frame	1			
9	Bolt M16x100	1	18	Lock Pin	4			

WARRANTY

Tradequip products have been carefully tested and inspected before shipment and are guaranteed to be free from defective materials and workmanship for a period of 12 months from the date of purchase except where tools are hired out when the guarantee period is ninety days from the date of purchase.

Should the machine develop any fault, please return the complete tool to your nearest authorised warranty repair agent or contact TQB Brands Pty Ltd Warranty team – warranty@tqbbrands.com.au.

If upon inspection it is found that the fault occurring is due to defective materials or workmanship, repairs will be carried out free of charge. This guarantee does not apply to normal wear and tear, nor does it cover any damage caused by misuse, careless or unsafe handling, alterations, accident, or repairs attempted or made by any personnel other than the authorised TQB Brands Pty Ltd repair agent.

This guarantee applies in lieu of any other guarantee expressed or implied and variations of its terms are not authorised.

Your TQB Brands Pty Ltd guarantee is not effective unless you can produce upon request a dated receipt or invoice to verify your proof of purchase within the 12 month period.

Consumer Guarantee

Our goods come with a guarantee that cannot be excluded under the Australian Consumer Law. You are entitled to a replacement or refund for a major failure and compensation for any other reasonably foreseeable loss or damage. You are also entitled to have the goods repaired or replaced if the goods fail to be of acceptable quality and the failure does not amount to a major failure.



All images and illustrations shown are for reference purposes only. All information, specifications and illustrations in this manual are based on the latest information available at the time of publication and are subject to change without notice. The information in this manual is periodically revised to ensure the latest information is included. Download the latest version of this manual and other related technical documentation from www.tqbbrands.com.au